

DATA SHEET

UAA3515A 900 MHz analog cordless telephone IC

Product specification
File under Integrated Circuits, IC17

2001 Dec 12

900 MHz analog cordless telephone IC**UAA3515A**

CONTENTS	8	LIMITING VALUES
1 FEATURES	9	HANDLING
1.1 Single frequency conversion FM receiver	10	THERMAL CHARACTERISTICS
1.2 Receiver baseband	11	CHARACTERISTICS
1.3 Synthesizer	12	PACKAGE OUTLINE
1.4 Transmitter	13	SOLDERING
1.5 Transmitter baseband	13.1	Introduction to soldering surface mount packages
1.6 Microcontroller interface	13.2	Reflow soldering
1.7 Power supplies	13.3	Wave soldering
2 APPLICATIONS	13.4	Manual soldering
3 GENERAL DESCRIPTION	13.5	Suitability of surface mount IC packages for wave and reflow soldering methods
4 ORDERING INFORMATION		
5 BLOCK DIAGRAM	14	DATA SHEET STATUS
6 PINNING	15	DEFINITIONS
7 FUNCTIONAL DESCRIPTION	16	DISCLAIMERS
7.1 Power supply and power management		
7.1.1 Power supply		
7.1.2 Power saving		
7.1.3 Current consumption		
7.2 FM receiver		
7.2.1 Data comparator		
7.3 Transmitter		
7.4 Synthesizer		
7.4.1 Calculation example		
7.5 Receiver baseband		
7.6 TX baseband		
7.7 Voltage regulator		
7.8 Low-battery detection		
7.9 Microcontroller interface		
7.9.1 Data registers		
7.9.2 Active modes		
7.9.3 Clock output divider		
7.9.4 FM-PLL centre frequency		
7.9.5 TX and RX gain control registers		
7.9.6 Carrier detector threshold programming		
7.9.7 Low-battery detection		
7.9.8 Power amplifier output level		
7.9.9 PLL charge pump current		
7.9.10 Volume control		
7.9.11 Crystal tuning capacitors		
7.9.12 Voltage reference adjustment		
7.9.13 Test mode		

900 MHz analog cordless telephone IC

UAA3515A

1 FEATURES**1.1 Single frequency conversion FM receiver**

- Integrated Low Noise Amplifier (LNA)
- Image reject mixer
- FM detector (10.7 MHz) with:
 - IF limiter
 - wide band PLL demodulator
 - output amplifier
 - Received Signal Strength Indicator (RSSI) output
- Carrier Detector (CD) with programmable threshold
- Programmable data amplifier (slicer) phase.

1.2 Receiver baseband

- Programmable receiver gain
- Expander
- Earpiece amplifier with volume control feature
- Data amplifier.

1.3 Synthesizer

- Crystal reference oscillator with integrated tuning capacitor
- Reference frequency divider
- Narrow band receiver PLL including VCO with integrated variable capacitance diodes
- Narrow band transmitter PLL including VCO with integrated variable capacitance diodes
- Integrated VCO circuits designed to function with external inductors etched directly as part of the printed-circuit board (cost-saving feature)
- Programmable clock divider with output buffer to drive the microcontroller.

1.4 Transmitter

- Internal buffered Power Amplifier (PA) with programmable gain
- Data transmission summing amplifier.

1.5 Transmitter baseband

- Programmable transmitter gain
- Microphone amplifier
- Compressor with Automatic Level Control (ALC) and hard limiter.

1.6 Microcontroller interface

- Three-wire serial interface.

1.7 Power supplies

- Voltage regulator for internal PLL supplies
- Selectable voltage doubler
- Programmable Low-Battery Detection (LBD) (time-multiplexed with RSSI carrier detector).

2 APPLICATIONS

- Analog cordless telephone sets (900 MHz).

3 GENERAL DESCRIPTION

The UAA3515A is a BiCMOS integrated circuit that performs all functions from antenna to microcontroller in reception and transmission for both base station and handset of a 900 MHz cordless telephone set. In addition, the implemented programming reduces significantly the amount of external components, board space and external adjustments required.

4 ORDERING INFORMATION

TYPE NUMBER	PACKAGE		
	NAME	DESCRIPTION	VERSION
UAA3515AHL	LQFP64	plastic, low profile quad flat package; 64 leads; body 10 × 10 × 1.4 mm	SOT314-2

900 MHz analog cordless telephone IC

UAA3515A

6 PINNING

SYMBOL	PIN	DESCRIPTION
MIXGND	1	mixer ground
RFIX	2	LNA voltage (X) input
RFIY	3	LNA voltage (Y) input
LNAGND	4	LNA ground
RXLF	5	RX PLL filter output
RXPD	6	RX phase detector voltage output
RSSI	7	RSSI output
V _{REG}	8	pin for internal voltage regulator
DGND	9	digital ground
V _{CC(CP)}	10	internal voltage doubler supply voltage (or positive supply voltage input) for charge pumps
CPGND	11	charge pump ground
V _{CC(PS)}	12	prescaler positive supply voltage input
TXPD	13	TX phase detector voltage input
TXLF	14	TX PLL filter output
PAGND1	15	power amplifier ground 1
PAO	16	power amplifier output
PAGND2	17	power amplifier ground 2
MODI	18	summing amplifier input
MODO	19	summing amplifier output
VTXGND	20	transmitter VCO ground
V _{CC(VTX)}	21	transmitter VCO positive supply voltage input
TXLOX	22	transmitter VCO voltage (X) to external inductor
TXLOY	23	transmitter VCO voltage (Y) to external inductor
V _{CC(ATX)}	24	transmitter audio positive supply voltage input
CCAP	25	external capacitor for compressor
TXO	26	audio transmitter output
MICI	27	microphone amplifier input
MICO	28	microphone amplifier output
CMPI	29	compressor input
VB	30	reference voltage
ATXGND	31	transmitter audio ground
XTALI	32	crystal input
XTALO	33	crystal output
CDLBD	34	CD or LBD open collector output (out-of-lock synthesizer receiver and/or transmitter in test mode)
CLKOUT	35	clock output (CMOS levels)
EN	36	enable input for serial interface
CLK	37	clock input for serial interface
DATA	38	data input for serial interface

900 MHz analog cordless telephone IC

UAA3515A

SYMBOL	PIN	DESCRIPTION
DATO	39	data amplifier open collector output
DATI	40	data amplifier input
ARXGND	41	audio receiver ground
EARO	42	earpiece amplifier output
EARI	43	earpiece amplifier input
V _{CC(ARX)}	44	audio receiver positive supply voltage input
ECAP	45	external capacitor for expander
RXAI	46	audio receiver input
LPFD	47	demodulator loop filter output
DETO	48	demodulator amplifier output
PLLO	49	demodulator amplifier negative input
LIMI	50	limiter input
IFGND	51	IF negative supply voltage
IFA2O	52	IF second amplifier output
IFA2I	53	IF second amplifier input
V _{CC(IF)}	54	IF positive supply voltage input
IFA1O	55	IF first amplifier output
IFA1I	56	IF first amplifier input
V _{CC(VRX)}	57	receiver VCO positive supply voltage input
RXLOX	58	receiver VCO voltage (X) to external inductor
RXLOY	59	receiver VCO voltage (Y) to external inductor
VRXGND	60	receiver VCO ground
V _{CC(BLO)}	61	receiver LO buffer positive supply voltage input
V _{CC(MIX)}	62	mixers positive supply voltage input
MIXO	63	mixer output
V _{CC(LNA)}	64	LNA positive supply voltage input

900 MHz analog cordless telephone IC

UAA3515A



900 MHz analog cordless telephone IC

UAA3515A

7 FUNCTIONAL DESCRIPTION**7.1 Power supply and power management****7.1.1 POWER SUPPLY**

The UAA3515A is used in a cordless telephone handset and in a base unit. The handset unit is battery powered and operates on three NiCd cells. The minimum supply voltage (V_{CC}) is 2.9 V.

7.1.2 POWER SAVING

When the UAA3515A is used in a handset, it is important to minimize current consumption. The main operating modes are:

- Active mode (talk): all blocks are powered
- RX mode: all circuits in the receiver part are powered

- Inactive mode: with the exception of the microcontroller interface, all circuits are powered-down. The crystal reference oscillator, the output clock buffer, the voltage regulator and the voltage doubler can be disabled separately. To reduce microcontroller current consumption, the crystal frequency to the clock output can be divided by 128. A low current consumption mode for the crystal oscillator can be programmed.

Latch memory is maintained in all modes. Blocks that are powered are shown in Table 1 per operating mode.

The crystal oscillator, the clock output buffer, the voltage reference adjustment, the power amplifier, the voltage doubler, the earpiece, the hard limiter and the ALC can be activated separately. Blocks that can be activated in each mode are shown in Table 2.

Table 1 Power operating modes

CIRCUIT BLOCK	ACTIVE MODE	RX MODE	INACTIVE MODE
Voltage reference adjustment	power ON	power ON	power OFF
RF receiver	power ON	power ON	power OFF
RX PLL	power ON	power ON	power OFF
RX and TX audio paths	power ON	power OFF	power OFF
RF TX (and PA, when enabled)	power ON	power OFF	power OFF

Table 2 Powered circuit blocks

CIRCUIT BLOCK	ACTIVE MODE	RX MODE	INACTIVE MODE
Crystal oscillator; note 1	power ON	power ON	power ON
Clock output buffer	power ON	power ON	power ON
Voltage reference enable; note 2	power ON	power ON	power ON
Power amplifier (PA2 = 1)	power ON	power OFF	power OFF
Voltage doubler enable; note 3	power ON	power ON	power ON
Hard limiter and ALC not disabled	power ON	power OFF	power OFF
Earpiece amplifier (earpiece enable = 1); note 4	power ON	power ON	power OFF

Notes

1. In RX and active mode, the crystal oscillator is activated automatically. An external frequency can be forced at the crystal pins XTALI and XTALO.
2. In RX and active mode, the voltage reference is enabled automatically (whether bit V_{REG} enable is logic 0 or 1).
3. If the voltage doubler is enabled, the crystal oscillator is activated automatically.
4. In inactive mode the amplifier is disabled automatically.

900 MHz analog cordless telephone IC

UAA3515A

7.1.3 CURRENT CONSUMPTION

The control bit values for selection of each mode and typical current consumption for the modes are shown in Table 3.

When clock out is activated there is an extra power demand proportional to the programmed output level (see Table 4 for examples). When bit Xtal high = 0 (oscillator is in low current consumption mode), the crystal in use must have losses less than 20 Ω to ensure oscillator start-up.

Table 3 Typical current consumption

$V_{CC} = 3.3$ V; $T_{amb} = 25$ °C; $f_{(i)xtal} = 10.24$ MHz.

POWER OPERATING MODE	CONDITIONS	TYPICAL CURRENT CONSUMPTION
Active mode		76 mA
RX mode		58 mA
Inactive mode	xtal active = 0; V_{REG} enable = 0; note 1	<10 μ A
	xtal active = 1; V_{REG} enable = 0; Xtal high = 0; note 1	230 μ A
	xtal active = 1; V_{REG} enable = 0; Xtal high = 1; note 1	330 μ A
	xtal active = 1; V_{REG} enable = 1; Xtal high = 1; note 1	550 μ A
	xtal active = 1; V_{REG} enable = 1; Xtal high = 0; note 2	690 μ A

Notes

1. Voltage doubler and clock output buffer disabled.
2. Voltage doubler enabled, clock output buffer disabled.

Table 4 Examples of additional current consumption

$V_{CC} = 3.3$ V; $T_{amb} = 25$ °C; $f_{(i)xtal} = 10.24$ MHz; $C_{L(CLKOUT)} = 14$ pF.

DIVIDER RATIO	CURRENT CONSUMPTION ADDITIONAL TO TYPICAL VALUE	
	CLKO level = 0	CLKO level = 1
1, 2, 2.5, 4 or 128	770 μ A	530 μ A
off	0	0

7.2 FM receiver

The FM receiver (see Fig.3) has a single frequency conversion architecture with integrated image rejection mixer that makes an external RF filter unnecessary. The Side Band Select (SBS) feature allows choice of frequency for RXLO to be in or out of the ISM band allowing use of the same IC type for both base station and handset. IF channel filtering (a compromise between price and performance) can be implemented simply using two or three external 10.7 MHz filters. The integrated FM PLL demodulator with limiter decreases significantly the number of pins and external components required.

900 MHz analog cordless telephone IC

UAA3515A

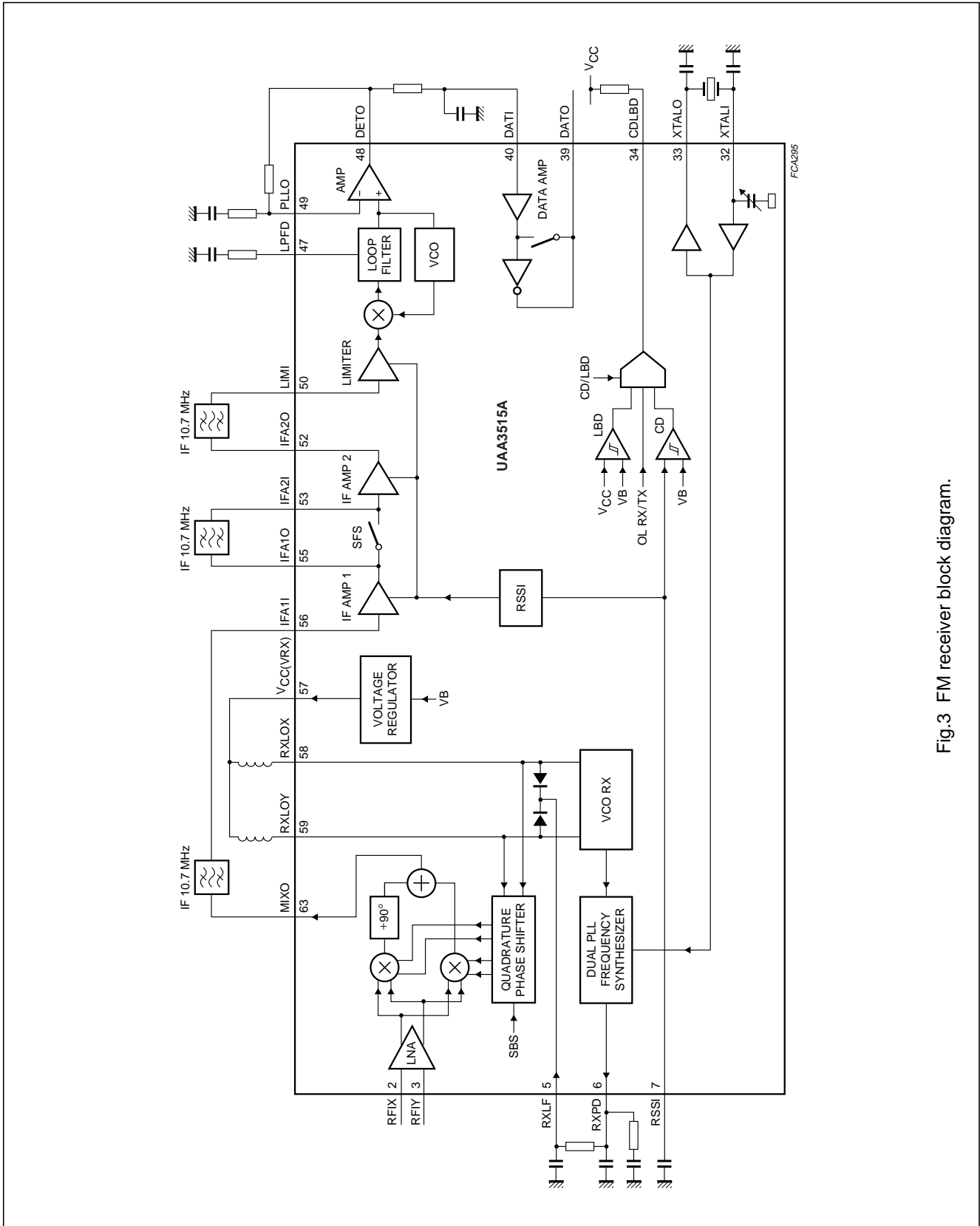

Fig.3 FM receiver block diagram.

900 MHz analog cordless telephone IC

UAA3515A

7.2.1 DATA COMPARATOR

The data comparator is an inverting hysteresis comparator. An external bandpass filter is connected between pins DETO and DATI (AC-coupled). The open-collector output is current limited to control the output signal slew rate. An external resistor of 180 kΩ should be connected between pin DATO and V_{CC}. An external capacitor in parallel with this resistor will reduce the slew rate.

7.3 Transmitter

The transmitter architecture is of the direct modulation type. The transmit VCO can be frequency modulated by speech or data (see Fig.4). An amplifier sums the modulating signal with the data TX signal before the VCO. Frequency control is affected by integrated variable capacitance diodes. To obtain the correct frequency, external inductors in series with the bonding wires and leadframe are required. The power amplifier is capable of driving a 50 Ω load. The level of the output signal PAO is programmed with two bits via the serial bus interface.



900 MHz analog cordless telephone IC

UAA3515A

7.4 Synthesizer

The crystal local oscillator and reference divider (see Fig.5) provide the reference frequency for the RX and TX PLLs. The 10-bit reference divider is programmed with respect to the crystal frequency and the desired RX and TX frequencies. The microcontroller operating frequency of 4.096 MHz is derived from a 16.384 MHz crystal frequency. The clock divider ratio can be programmed to 1, 2, 2.5, 4 or to 128; ratio 128 is chosen in sleep mode to save current in the microcontroller section. Clock output (pin CLKOUT) is an emitter follower output.

The 16-bit TX counter is programmed for the desired transmit channel frequency. Similarly, the 16-bit RX counter is programmed for the desired local oscillator frequency. The divider counter comprises a 6-bit prescaler with division ratios (R) from 64 to 127, and a 10-bit CMOS divider with division ratios (C) from 8 to 1023. The full counter provides division ratios from 512 to 65535. Settings of RX and TX counters are calculated as follows:

$$C = \text{int} \frac{M}{64}$$

$$R = M - C \times 64$$

(where M is the division ratio between VCO frequency and the reference frequency).

7.4.1 CALCULATION EXAMPLE

Given:

$$\text{RF input frequency } f_{i(\text{RF})} = 903 \text{ MHz}$$

$$\text{VCO RX } f_{\text{VCO}(\text{RX})} = 892.3 \text{ MHz}$$

$$f_{\text{IF}} = 10.7 \text{ MHz}$$

$$\text{VCO TX } f_{\text{VCO}(\text{TX})} = 925.6 \text{ MHz}$$

$$\text{Internal comparison frequency} = 20 \text{ kHz} \\ (f_{\text{XTAL}} = 10.24 \text{ MHz})$$

We have:

$$\text{Reference divider} = 512 \text{ (100000000)}$$

$$M_{\text{RX}} = \frac{892.3 \times 10^6}{20 \times 10^3} = 44615$$

$$C_{\text{RX}} = 697 \text{ (1010111001)} \text{ and } R_{\text{RX}} = 7 \text{ (000111)}$$

and

$$M_{\text{TX}} = \frac{925.6 \times 10^6}{20 \times 10^3} = 46280$$

$$C_{\text{TX}} = 723 \text{ (1011010011)} \text{ and } R_{\text{TX}} = 8 \text{ (001000)}$$

VCOs and variable capacitance diodes are integrated. Resonance inductors are shared between bonding wires, leadframe of the package and external inductors. Costs can be reduced by etching external inductors directly onto the printed-circuit board.

An on-chip selectable voltage doubler is provided to enable a larger tuning range of both VCOs. The phase detectors have current drive type outputs with selection possibilities between 400 and 800 μA .

900 MHz analog cordless telephone IC

UAA3515A

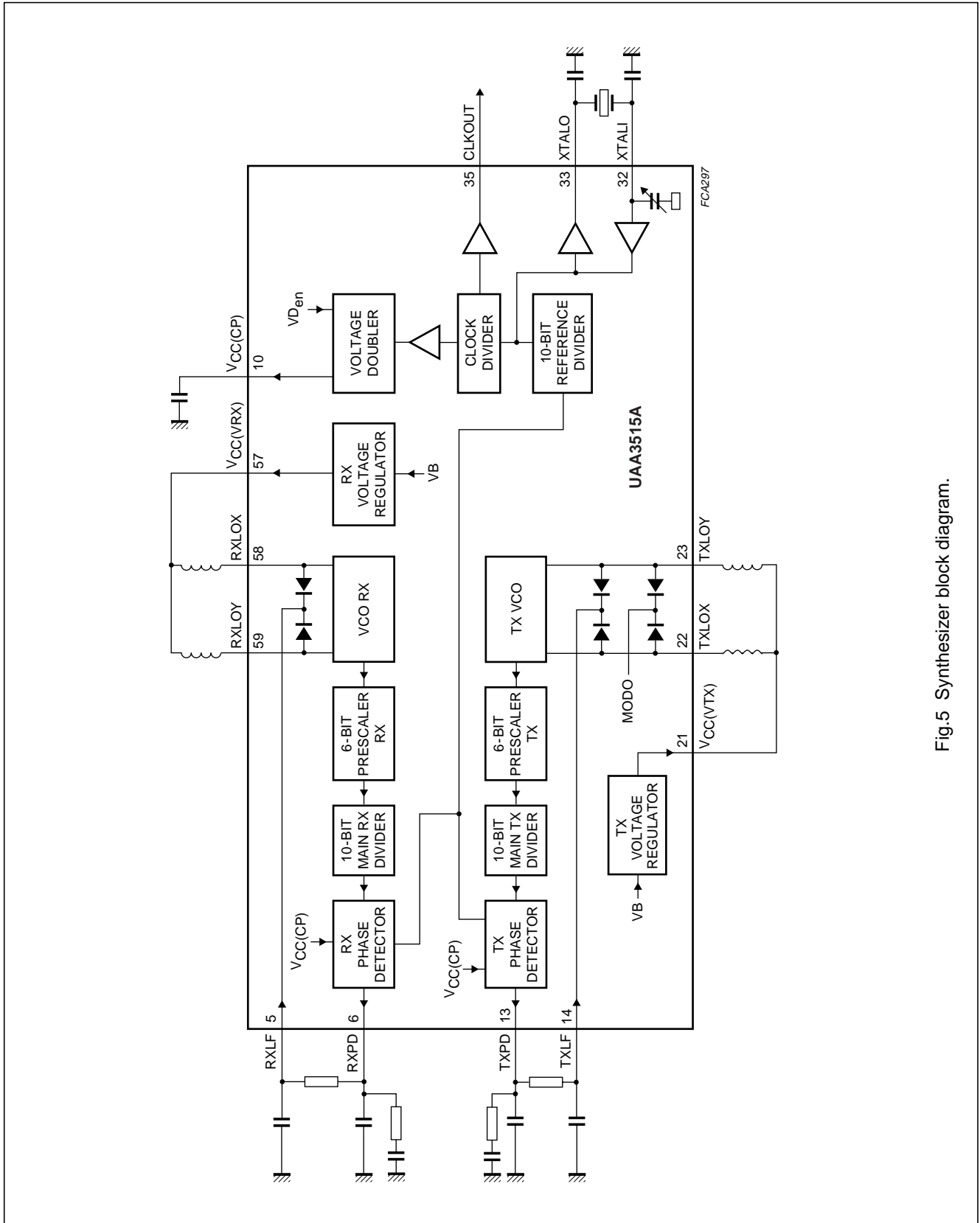

Fig.5 Synthesizer block diagram.

900 MHz analog cordless telephone IC

UAA3515A

7.5 Receiver baseband

This section covers the RX audio path from pins RXAI to EARO (see Fig.6). The RXAI input signal is AC-coupled.

The microcontroller sets the value of the RX gain in 32 linear steps of 0.5 dB. The RX baseband has a mute function and an expander with characteristics as shown in Fig.7.

For audio level adjustment and, potentially for software volume control, setting the RX gain provides a dynamic range of 31 dB. This is achieved by the expander slope that multiplies the RX gain by a factor of two for each gain step thus giving 1 dB steps measured at the earpiece amplifier output.

The earpiece amplifier is a rail-to-rail inverting operational amplifier. The non-inverting input is connected to the internal reference voltage at pin VB. Software volume control on the earpiece amplifier is achieved by using an integrated switched feedback resistor R_{int} . The volume control tuning range is 14 dB. Hardware volume control is achieved by switching externally the earpiece feedback resistor R_{ext} .



Fig.6 RX baseband block diagram.

900 MHz analog cordless telephone IC

UAA3515A



7.6 TX baseband

This section covers the TX audio path from pins MIC1 to TXO (see Fig.8). The input signal at pin MIC1 is AC-coupled. There is another AC-coupling at the microphone amplifier output.

The microphone amplifier is an inverting operational amplifier whose gain can be set by external resistors. The non-inverting input is connected to the internal reference voltage VB. External resistors are used to set the gain and frequency response.

The TX baseband has a compressor with the characteristic shown in Fig.9. The ALC provides a 'soft' limit to the output signal swing as the input voltage increases slowly (i.e. a sine wave is maintained at the output). A hard limiter clamps the compressor output voltage at 1.26 V (peak-to-peak). The ALC and the hard limiter can be disabled via the microcontroller interface. The hard limiter is followed by a mute circuit. The TX gain is digitally programmable in 32 steps of 0.5 dB.

900 MHz analog cordless telephone IC

UAA3515A

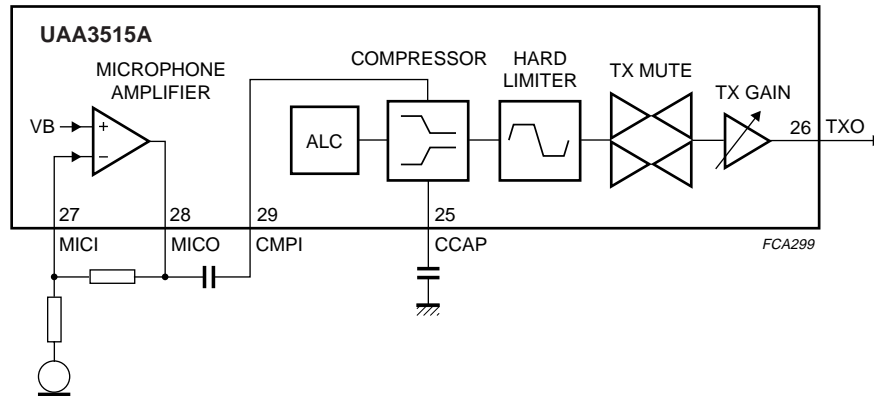
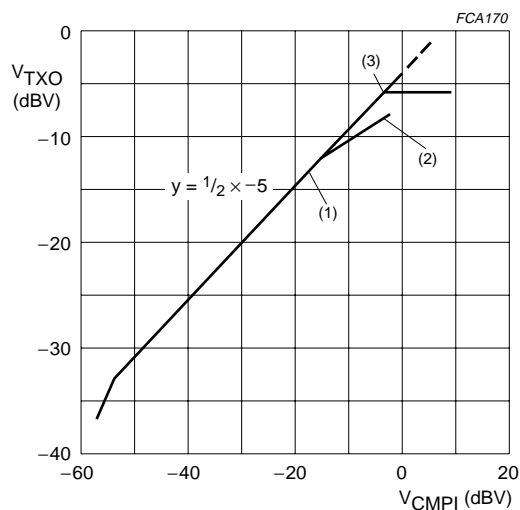

Fig.8 TX baseband block diagram.



- (1) Slowly changing ALC signals:
 $V_{CMP1} = -16$ dBV;
 $V_{TXO} = -13$ dBV.
- (2) $V_{CMP1} = -2.5$ dBV;
 $V_{TXO} = -11.5$ dBV.
- (3) Hard limiting signals:
 $V_{CMP1} = -4$ dBV;
 $V_{TXO} = -1.26$ V (p-p).

Fig.9 Compressor characteristic showing TXO as a function of CMP1.

900 MHz analog cordless telephone IC

UAA3515A

7.7 Voltage regulator

Pin V_{REG} provides the internal supply voltage for the RX and TX PLLs. It is regulated at 2.7 V nominal voltage. Two capacitors of 4.7 μ F and 100 nF must be connected to pin V_{REG} to filter and stabilize this regulated voltage. The tolerance of the regulated voltage is initially $\pm 8\%$ but is improved to $\pm 2\%$ after the internal bandgap voltage reference is adjusted through the microcontroller.

7.8 Low-battery detection

The low-battery detector measures the voltage level of the V_{CC} using a resistance divider and a comparator. One input of the comparator is connected to VB, the other to the middle point of the resistance divider. The comparator has a built-in hysteresis to prevent spurious switching. The precision of the detection depends on the divider accuracy, the comparator offset and the accuracy of the reference voltage VB. The output is multiplexed at pin CDLBD. When the battery voltage level is under the threshold voltage the output CDLBD is going LOW.

7.9 Microcontroller interface

The DATA, CLK and EN pins provide a 3-wire unidirectional serial interface for programming the reference counters, the transmit and receive channel divider-counters and the control functions.

The interface consists of 19-bit shift registers connected to a matrix of registers organized as 7 words of 16 bits (all are control registers). The leading 16 bits include the data D15 to D0. The trailing 3 bits set up the address AD2 to AD0. The data is entered with the most significant bit D15 first and the last bit is AD0.

Pins DATA and CLK are used to load data into the shift register. Figure 10 shows the timing required on all pins. Data is clocked into the shift registers on negative clock transitions.

A new clock divider ratio is enabled using an extra EN rising edge. Minimum hold time is 50 ns and during this time no clock cycle is allowed. These extra EN edges can be applied to all the data programmed but will have no effect on the serial interface programming.

The pins DATA, CLK and EN are supplied by V_{REG} . The ESD protection diodes on these pins are connected to V_{CC} .

900 MHz analog cordless telephone IC

UAA3515A



900 MHz analog cordless telephone IC

UAA3515A

Table 7 Data register content description

DATA REGISTER NAME	BIT	DESCRIPTION
SBS ⁽¹⁾	1	sideband select: (LO + IF) frequency is rejected
	0	sideband select: (LO – IF) frequency is rejected
SFS	1	second filter select: the second IF filter is selected
	0	second filter select: the second IF filter is deselected; note 2
CLKO level ⁽³⁾	1	clock output signal is regulated with respect to V_{REG} ; $V_{CLKOUT(p-p)} = 1\text{ V}$
	0	clock output signal is regulated with respect to V_{CC} ; $V_{CLKOUT(p-p)} = 1.4\text{ V}$
Xtal active	1	crystal oscillator is active
	0	crystal oscillator is disable
Xtal high ⁽⁴⁾	1	oscillator is in normal operation
	0	oscillator is in low current consumption mode
DATA phase ⁽⁵⁾	1	DATA signal is inverted
	0	DATA signal is not inverted (inverter bypassed)
ALC disable	1	ALC disabled
	0	normal operation
Hard limiter enable	1	hard limiter enabled
	0	hard limiter disabled
RX mute	1	RX channel muted
	0	normal operation
TX mute	1	TX channel muted
	0	normal operation
V_{REG} enable	1	V_{REG} enabled
	0	V_{REG} disabled and tied to V_{CC} (in inactive mode)
Doubler enable ⁽⁶⁾	1	voltage doubler is enabled
	0	voltage doubler is disabled
Earpiece enable	1	earpiece enabled (can be used in RX mode for specific features)
	0	earpiece disabled

Notes

- Sideband select enables the user to have the RX local oscillator in or out of the ISM band and to use the same IC in both handset and base.
- A 4.5 dB insertion loss in the filter is assumed.
- The clock output signal will be AC-coupled with the XTALI pin of the microcontroller. The external resonator from the microcontroller can be removed. Caution needs to be taken that no radiation is present on the PCB
- In inactive mode, the crystal oscillator is a major contributor to the full current consumption. When Xtal high = 0, the current mode can be programmed to save current and in inactive mode this comes to full current consumption at 230 μA (see Section 7.1.3). When Xtal high = 1, the crystal oscillator current is increased by 100 μA .
- Depending on the SBS-bit and the protocol chosen, the data may be inverted between the base and handset data transmission.
- Minimum supply voltage for the IC is 2.9 V which limits the voltage swing on both charge pumps to approximately 2.3 V. With the voltage doubler or with an external high supply voltage on pin $V_{CC(CP)}$, the extra voltage availability can be used to enhance the tuning range of the VCOs variable capacitance diodes. To save current in inactive mode, voltage doubler clock is the same as CLKO clock (can be programmed to $\frac{XTAL}{128}$); in other modes the voltage doubler clock is XTALI divided by two.

900 MHz analog cordless telephone IC

UAA3515A

7.9.2 ACTIVE MODES

Table 8 Active mode bit selection; note 1

BIT 1	BIT 0	DESCRIPTION
0	X	inactive mode
1	0	RX mode
1	1	active mode

Note

1. See details on activated blocks in Section 7.1.2.

7.9.3 CLOCK OUTPUT DIVIDER

The crystal oscillator produces a reference frequency that is divided and buffered to drive a microcontroller. Table 9 gives the division ratios. The buffer is a CMOS output which can drive up to 20 pF at 10 MHz in both CLKO level modes.

Table 9 Clock division register

BIT 2	BIT 1	BIT 0	SELECT	CLOCK DIVISION RATIO
0	0	0	0	output disabled
0	0	1	1	2
0	1	0	2	2.5
0	1	1	3	4
1	0	0	4	1
1	0	1	5	128

When the clock output signal is used, an external RC filter connected to pin CLKOUT can be added to limit clock waveform edges and therefore clock radiation on the printed-circuit board.

To supply the clock to the microcontroller and save current in the handset, an external low power resonator may be used and the clock output disabled (000) as well as the crystal oscillator (Xtal active = 0). In power saving mode, the divider ratio can be programmed down to 128 to reduce the microcontroller power consumption.

900 MHz analog cordless telephone IC

UAA3515A

7.9.4 FM-PLL CENTRE FREQUENCY

This register allows the centre frequency of the VCO to be calibrated within the FM PLL to align the frequency as close as possible to the nominal 10.7 MHz frequency.

Table 10 FM-PLL VCO tuning register

BIT 4	BIT 3	BIT 2	BIT 1	BIT 0	SELECT	CENTRE FREQUENCY SHIFT (MHz)
0	0	0	0	0	0	3.0
0	0	0	0	1	1	2.8
0	0	0	1	0	2	2.6
0	0	0	1	1	3	2.4
0	0	1	0	0	4	2.2
0	0	1	0	1	5	2.0
0	0	1	1	0	6	1.8
0	0	1	1	1	7	1.6
0	1	0	0	0	8	1.4
0	1	0	0	1	9	1.2
0	1	0	1	0	10	1.0
0	1	0	1	1	11	0.8
0	1	1	0	0	12	0.6
0	1	1	0	1	13	0.4
0	1	1	1	0	14	0.2
0	1	1	1	1	15	0
1	0	0	0	0	16	-0.2
1	0	0	0	1	17	-0.4
1	0	0	1	0	18	-0.6
1	0	0	1	1	19	-0.8
1	0	1	0	0	20	-1.0
1	0	1	0	1	21	-1.2
1	0	1	1	0	22	-1.4
1	0	1	1	1	23	-1.6
1	1	0	0	0	24	-1.8
1	1	0	0	1	25	-2.0
1	1	0	1	0	26	-2.2
1	1	0	1	1	27	-2.4
1	1	1	0	0	28	-2.6
1	1	1	0	1	29	-2.8
1	1	1	1	0	30	-3.0
1	1	1	1	1	31	-3.2

900 MHz analog cordless telephone IC

UAA3515A

7.9.5 TX AND RX GAIN CONTROL REGISTERS

The TX and RX audio signal paths each have a programmable gain block. If a TX or RX voltage gain other than the nominal power-up default is desired it can be programmed through the microcontroller interface. The gain blocks can be used during final telephone testing to adjust electronically gain tolerances in the telephone system. The RX gain and the TX gain controls have steps of 0.5 dB covering a dynamic range of -7.5 to $+8.0$ dB. Measured on the earpiece amplifier output, RX gain steps are multiplied by 2 due to the expander slope. A dynamic range of -15 to $+16$ dB at the earpiece amplifier supports a volume control feature that can be implemented in the telephone and compensate for gain tolerances. Volume control can also be performed externally with hardware switches on various resistor values.

Table 11 RX and TX gain control registers

BIT 4	BIT 3	BIT 2	BIT 1	BIT 0	GAIN CONTROL	RX GAIN (dB)	EARO (dB)	TX GAIN (dB)
0	0	0	0	0	0	-7.5	-15.0	-7.5
0	0	0	0	1	1	-7.0	-14.0	-7.0
0	0	0	1	0	2	-6.5	-13.0	-6.5
0	0	0	1	1	3	-6.0	-12.0	-6.0
0	0	1	0	0	4	-5.5	-11.0	-5.5
0	0	1	0	1	5	-5.0	-10.0	-5.0
0	0	1	1	0	6	-4.5	-9.0	-4.5
0	0	1	1	1	7	-4.0	-8.0	-4.0
0	1	0	0	0	8	-3.5	-7.0	-3.5
0	1	0	0	1	9	-3.0	-6.0	-3.0
0	1	0	1	0	10	-2.5	-5.0	-2.5
0	1	0	1	1	11	-2.0	-4.0	-2.0
0	1	1	0	0	12	-1.5	-3.0	-1.5
0	1	1	0	1	13	-1.0	-2.0	-1.0
0	1	1	1	0	14	-0.5	-1.0	-0.5
0	1	1	1	1	15	0	0	0
1	0	0	0	0	16	0.5	1.0	0.5
1	0	0	0	1	17	1.0	2.0	1.0
1	0	0	1	0	18	1.5	3.0	1.5
1	0	0	1	1	19	2.0	4.0	2.0
1	0	1	0	0	20	2.5	5.0	2.5
1	0	1	0	1	21	3.0	6.0	3.0
1	0	1	1	0	22	3.5	7.0	3.5
1	0	1	1	1	23	4.0	8.0	4.0
1	1	0	0	0	24	4.5	9.0	4.5
1	1	0	0	1	25	5.0	10.0	5.0
1	1	0	1	0	26	5.5	11.0	5.5
1	1	0	1	1	27	6.0	12.0	6.0
1	1	1	0	0	28	6.5	13.0	6.5
1	1	1	0	1	29	7.0	14.0	7.0
1	1	1	1	0	30	7.5	15.0	7.5
1	1	1	1	1	31	8.0	16.0	8.0

900 MHz analog cordless telephone IC

UAA3515A

7.9.6 CARRIER DETECTOR THRESHOLD PROGRAMMING

When the LBD active register = 0, the carrier detector is enabled and the signal CDout is sent to the output pin CDLBD. If RSSI is above the programmed RSSI level, CDLBD = 0; if RSSI is below the programmed level then CDLBD = 1. The carrier detector gives an indication if a carrier signal is present on the selected channel. The carrier detector has a nominal value and tolerance, if a different carrier detect threshold value is desired, this can be programmed through the microcontroller interface. If the carrier detect range is to be scaled, an external resistor should be connected between pin RSSI and ground. CD control = 10011 which corresponds to RSSI = 0.86 V (typical DC value).

Table 12 CD levels register

BIT 4	BIT 3	BIT 2	BIT 1	BIT 0	SELECT	RSSI VOLTAGE THRESHOLD DETECT (V)
0	0	0	0	0	0	0.1
0	0	0	0	1	1	0.14
0	0	0	1	0	2	0.18
0	0	0	1	1	3	0.22
0	0	1	0	0	4	0.26
0	0	1	0	1	5	0.3
0	0	1	1	0	6	0.34
0	0	1	1	1	7	0.38
0	1	0	0	0	8	0.42
0	1	0	0	1	9	0.46
0	1	0	1	0	10	0.5
0	1	0	1	1	11	0.54
0	1	1	0	0	12	0.58
0	1	1	0	1	13	0.62
0	1	1	1	0	14	0.66
0	1	1	1	1	15	0.7
1	0	0	0	0	16	0.74
1	0	0	0	1	17	0.78
1	0	0	1	0	18	0.82
1	0	0	1	1	19	0.86
1	0	1	0	0	20	0.9
1	0	1	0	1	21	0.94
1	0	1	1	0	22	0.98
1	0	1	1	1	23	1.02
1	1	0	0	0	24	1.06
1	1	0	0	1	25	1.1
1	1	0	1	0	26	1.14
1	1	0	1	1	27	1.18
1	1	1	0	0	28	1.22
1	1	1	0	1	29	1.26
1	1	1	1	0	30	1.3
1	1	1	1	1	31	1.34

900 MHz analog cordless telephone IC

UAA3515A

7.9.7 LOW-BATTERY DETECTION

When the LBD active register = 1, the low battery detector is enabled and the signal BDout passes to the output CDLBD. If V_{CC} is below the programmed LBD level, CDLBD = 0; if not below the programmed level, CDLBD = 1. The power-up default value is 110.

Table 13 LBD level register

BIT 2	BIT 1	BIT 0	SELECT	LOW BATTERY VOLTAGE DETECTION; NOMINAL VALUE (V)
0	0	0	0	3.5
0	0	1	1	3.4
0	1	0	2	3.3
0	1	1	3	3.2
1	0	0	4	3.1
1	0	1	5	3.0
1	1	0	6	2.9
1	1	1	7	2.8

7.9.8 POWER AMPLIFIER OUTPUT LEVEL

The power amplifier output register has two bits to modify the output power and one bit to disable the power amplifier (PA output bit 2 = 0). Duplexer matching ($300\ \Omega$ to $50\ \Omega$) is performed using a parallel inductive/series capacitive network. Output power on $50\ \Omega$ is specified in Table 14. To get power on the antenna, duplexer insertion loss should be removed. At maximum power, 3 mA extra DC current is consumed compared with the current at the minimum power settings.

Table 14 PA output register

BIT 2	BIT 1	BIT 0	SELECT	PA OUTPUT POWER (dBm)	2nd HARMONIC (dBm)	3rd HARMONIC (dBm)	4th HARMONIC (dBm)
0	X	X	–	PA inactive	–	–	–
1	0	0	0	1.0	–17	–327	–34
1	0	1	1	1.9	–19	–29	–34
1	1	0	2	2.5	–23	–33	–36
1	1	1	3	3.1	–23	–36	–40

7.9.9 PLL CHARGE PUMP CURRENT

Performance of the PLLs can be improved by increasing charge pump current. Then a programmable current on both RX and TX charge pump can be programmed. RX and TX charge pump currents are programmed independently. When the RX or TX charge pump current register = 0, charge pump current is 400 μ A; when it is set to 1, charge pump current is 800 μ A.

900 MHz analog cordless telephone IC

UAA3515A

7.9.10 VOLUME CONTROL

The register VCTL enables the volume control of the earpiece amplifier to be set to a predefined gain. This is achieved by switched feedback resistor R_{int} . The optional resistor R_{ext} , connected between pins EARI and EARO provides the hardware control.

Table 15 Volume control bit selection

BIT 1	BIT 0	R_{int} (k Ω)	R_{ext} (k Ω)	G_{EAR} (dB)
0	0	14	none	0
0	1	24	none	4.7
1	0	41	none	9.3
1	1	70.2	none	14
1	1	70.2	100	9.4
1	1	70.2	33	4.1
1	1	70.2	15	-1

7.9.11 CRYSTAL TUNING CAPACITORS

On-chip crystal reference tuning is provided to compensate for frequency spread over process and temperature changes. An external capacitor should be connected at pin XTALI; the value of the capacitor should be approximately 3 pF less than the capacitance of pin XTALO. Internally, a programmable capacitance is available in parallel with the XTALI pin. Tuning capacitance values are in the range 0 to 4.5 pF; see Table 16.

Table 16 Xtal tuning cap register

BIT 3	BIT 2	BIT 1	BIT 0	SELECT	CAPACITANCE (pF)
0	0	0	0	0	0.2
0	0	0	1	1	0.5
0	0	1	0	2	0.8
0	0	1	1	3	1.1
0	1	0	0	4	1.4
0	1	0	1	5	1.7
0	1	1	0	6	2.0
0	1	1	1	7	2.3
1	0	0	0	8	2.6
1	0	0	1	9	2.9
1	0	1	0	10	3.2
1	0	1	1	11	3.5
1	1	0	0	12	3.8
1	1	0	1	13	4.1
1	1	1	0	14	4.4
1	1	1	1	15	4.7

900 MHz analog cordless telephone IC

UAA3515A

7.9.12 VOLTAGE REFERENCE ADJUSTMENT

An internal 1.5 V bandgap voltage reference provides the voltage reference for the low battery detect circuits, the V_{REG} voltage regulator, the V_B reference and all internal analog references. In inactive mode, the adjustment is disabled.

Table 17 Voltage reference adjust register

BIT 2	BIT 1	BIT 0	SELECT	NOMINAL VOLTAGE REFERENCE
0	0	0	0	-7%
0	0	1	1	-5%
0	1	0	2	-3%
0	1	1	3	-1%
1	0	0	4	1%
1	0	1	5	3%
1	1	0	6	5%
1	1	1	7	7%

7.9.13 TEST MODE

Test mode bits are used only for test in production and application tuning. The test bits must be set to 0 for normal operation. Out-of-lock of synthesizers RX or TX can be monitored indirectly on pin CDLBD: the width of the 'glitch' that occurs with out-of-lock gives a direct indication of the phase error on the PLL RX and/or TX. To tune the external inductors of the RX and TX VCOs, a defined division ratio has to be programmed into the dividers, and then the image frequency of the VCO can be read on pin CDLBD. Test mode can also be used to check the division ratio: a frequency can be forced on the VCO or crystal pins and the programmed frequency can be read on pin CDLBD. There is a divide-by-2 stage before the CDLBD pin, therefore all frequencies are divided-by-2. When both charge pumps are in the high-impedance state, the VCOs can be measured as stand alone.

Table 18 Test mode register

BIT 2	BIT 1	BIT 0	SELECT
0	0	0	normal operation
0	0	1	XOR between internal signals 'up' and 'down' of the RX synthesizer
0	1	0	XOR between internal signals 'up' and 'down' of the TX synthesizer
0	1	1	XOR between internal signals 'up' and 'down' of the RX or TX synthesizers
1	0	0	reference divider output divided by 2
1	0	1	prescaler and main divider RX divided by 2
1	1	0	prescaler and main divider TX divided by 2
1	1	1	both synthesizer charge pumps are in high-impedance-state

900 MHz analog cordless telephone IC

UAA3515A

8 LIMITING VALUES

In accordance with the Absolute Maximum Rating System (IEC 60134).

SYMBOL	PARAMETER	MIN.	MAX.	UNIT
V_{CC}	supply voltage	-0.3	+6.0	V
T_{stg}	storage temperature	-55	+125	°C
T_{amb}	ambient temperature	-20	+80	°C

9 HANDLING

Inputs and outputs are protected against electrostatic discharge in normal handling. However, to be totally safe, it is desirable to take normal precautions appropriate to handling MOS devices. Do not operate or store near strong electrostatic fields.

Meets Class 1 ESD test requirements (human body model) in accordance with "EIA/JESD22-A114-B (June 2001)" and class A ESD test requirements (machine model) in accordance with "EIA/JESD22-A115-B (October 1997)".

10 THERMAL CHARACTERISTICS

SYMBOL	PARAMETER	CONDITIONS	VALUE	UNIT
$R_{th(j-a)}$	thermal resistance from junction to ambient	in free air	68	K/W

900 MHz analog cordless telephone IC

UAA3515A

11 CHARACTERISTICS

$V_{CC} = V_{CC(PS)} = V_{CC(ATX)} = V_{CC(ARX)} = V_{CC(IF)} = V_{CC(BLO)} = V_{CC(MIX)} = V_{CC(LNA)} = 3.3\text{ V}$; $T_{amb} = 25\text{ °C}$; unless otherwise specified.

SYMBOL	PARAMETER	CONDITIONS	MIN.	TYP.	MAX.	UNIT
Supplies						
V_{CC}	positive supply voltage to pins $V_{CC(PS)}$; $V_{CC(ATX)}$; $V_{CC(ARX)}$; $V_{CC(IF)}$; $V_{CC(BLO)}$; $V_{CC(MIX)}$; $V_{CC(LNA)}$		2.9	3.3	5.5	V
PLL VOLTAGE REGULATOR						
$V_{O(VREG)}$	regulated output voltage	$V_{REG}\text{ enable} = 0$ $V_{REG}\text{ enable} = 1$ inactive mode before V_{ref} adjustment after V_{ref} adjustment	– 2.5 2.5 2.65	V_{CC} 2.7 2.7 2.7	– 2.9 2.9 2.75	V V V V
$I_{O(VREG)}$	output current	$C_{VREG} = 1\ \mu\text{F}$	–	–	3	mA
LOW BATTERY DETECTION: LBD active = 1						
V_{LBD}	detection voltage range		2.8	–	3.5	V
ΔV_{LBD}	number of detection voltage steps		–	8	–	steps
V_{hys}	comparator hysteresis	$[V_{CC(high)} - V_{CC(low)}] \times \frac{V_{VB}}{V_{th}}$	–	18	–	mV
$\Delta V_{CC}/V_{CC}$	LBD accuracy	measured after V_{ref} adjusted; LBD = 010	–	0.5	5	%
Receiver section						
LNA AND IMAGE REJECTION MIXER; $f_{i(RX)} = 903\text{ MHz}$						
$R_{i(RX)}$	RF input resistance	balanced	–	110	–	Ω
$C_{i(RX)}$	RF input capacitance	balanced	–	0.7	–	pF
$f_{i(RX)}$	RF input frequency		902	903	928	MHz
$RL_{i(RX)}$	return loss on match RF input	note 1	10	–	–	dB
$G_{conv(p)(RX)}$	conversion power gain	balun input to MIXO pin; matched to $330\ \Omega$	–	22	–	dB
$CP1_{RX}$	1 dB input compression point	note 1	–	–23	–	dBm
$IP3_{RX}$	3 rd order intercept point		–	–13	–	dBm
NF_{RX}	overall noise figure, RF front end	IF section excluded	–	4	5	dB
IR	image frequency rejection	in band of interest	26	45	–	dB
$R_{L(RX)}$	IF resistive output load	on pin MIXO	–	330	–	Ω
$C_{L(RX)}$	IF capacitive output load	on pin MIXO	–	–	3	pF

900 MHz analog cordless telephone IC

UAA3515A

SYMBOL	PARAMETER	CONDITIONS	MIN.	TYP.	MAX.	UNIT
IF AMPLIFIER SECTION: $f_0 = 10.7$ MHz						
G_{IFAMP1}	voltage or power gain of first IF amplifier	330 Ω matched input and output; SFS = 1; measured at amplifier output	–	22.5	–	dB
NF_{IFAMP1}	noise figure of first IF amplifier	330 Ω matched input and output	–	7	–	dB
G_{IFAMP2}	voltage or power gain of second IF amplifier	330 Ω matched input and output; SFS = 1; measured at amplifier output	–	25	–	dB
NF_{IFAMP2}	noise figure of second IF amplifier	330 Ω matched input and output	–	14	–	dB
G_{IFAMP}	gain of IF amplifier section	330 Ω matched input and output; SFS = 0	–	43	–	dB
NF_{IFAMP}	noise figure of IF amplifier section		–	7.5	–	dB
PLL DEMODULATOR: $f_0 = 10.7$ MHz; $f_{dev} = \pm 25$ kHz; $f_{mod} = 1$ kHz						
$\Delta f_{VCO}/\Delta V$	VCO gain	after calibration	–	760	–	kHz/V
f_{VCO}	VCO centre frequency (free running)	open loop; all conditions	7.0	10.7	15.0	MHz
Δf_{VCO}	VCO frequency adjustment	see Table 10	–	32	–	steps
$f_{VCO(step)}$	VCO centre frequency step size		–	200	–	kHz
BW_{demod}	demodulator –3 dB bandwidth	loop filter: see note 2	10	–	–	kHz
$f_{dev(max)}$	maximum frequency deviation		–	–	± 75	kHz
$R_{L(DETO)}$	demodulator external load on pin DETO		5	–	–	k Ω
$V_{o(DETO)(RMS)}$	PLL output voltage on pin DETO (RMS value)	TX mode; $R_{L(DETO)} = 10$ k Ω ; amplifier gain = 10; note 3	–	100	350	mV
$V_{o(DETO)(DC)}$	PLL output DC voltage on pin DETO	microcontroller adjustable DC component	1.2	1.4	1.6	V
FM RECEIVER: $f_0 = 903$ MHz; $f_{dev} = \pm 25$ kHz; $f_{mod} = 1$ kHz; $R_{L(EARO)} = 150$ Ω in series with 10 μ F (all with CCITT filter)						
SR_{FI}	receiver sensitivity	measured at antenna; duplexer insertion loss = 3 dB; input level for 12 dB SINAD; bandwidth = 100 kHz RX mode TX mode; PA = 10; $V_{EARO(RMS)} = 200$ mV; TX to RX duplexer isolation is 35 dB minimum	– –	–115 –113.5	– –	dBm dBm

900 MHz analog cordless telephone IC

UAA3515A

SYMBOL	PARAMETER	CONDITIONS	MIN.	TYP.	MAX.	UNIT
S/N_{FM}	signal-to-noise ratio	TX mode; $V_{i(RF)} = -80$ and -40 dBm; PA = 10; CLKO level = 0; $V_{EARO(RMS)} = 200$ mV	40	45	–	dB
THD_{FM}	total harmonic distortion	TX mode; $f_{dev} = \pm 60$ kHz; $V_{i(RF)} = -80$ and -40 dBm; PA = 10; CLKO level = 0; $V_{EARO(RMS)} = 500$ mV; measured without CCITT filter	–	0.6	2	%
RSSI AND CARRIER DETECTION: $V_B = 1.5$ V						
RSSI	output current dynamic range		–	68	–	dB
V_{OH}	HIGH-level output voltage at pin CDLBD	$V_{i(LIM)(RMS)} = 0$ mV; CD = 10011	$0.9V_{CC}$	–	–	V
V_{OL}	LOW-level output voltage at pin CDLBD	$V_{i(LIM)} = 0.1$ V (RMS); CD = 10011	–	–	$0.1V_{CC}$	V
R_{int}	internal resistance between pin RSSI and V_{CC}		–	175	–	k Ω
V_{det}	voltage detection range		0.05	–	1.6	V
ΔV_{det}	voltage detection step		–	40	–	mV
V_{hys}	hysteresis		–	45	–	mV
$V_{th(CD)}$	carrier sense threshold	microcontroller programmable	–	32	–	steps
DATA COMPARATOR						
$V_{i(DATC)(p-p)}$	comparator input signal (peak-to-peak value)		100	–	–	mV
$V_{hys(DATC)}$	hysteresis		25	40	75	mV
$V_{th(DATC)}$	pin DATI threshold voltage		–	$V_{CC} - 0.9$	–	V
$Z_{i(DATC)}$	pin DATI input impedance		150	240	–	k Ω
V_{OH}	HIGH-level output voltage	$V_{i(DATI)} = V_{CC} - 1.4$ V	$0.9V_{CC}$	–	–	V
V_{OL}	LOW-level output voltage	$V_{i(DATI)} = V_{CC} - 0.4$ V	–	–	$0.1V_{CC}$	V
I_{OHsink}	pin DATO output sink current	$V_{i(DATI)} = V_{CC} - 0.4$ V; $V_{o(DATO)} = 0.1V_{CC}$	–	40	–	μ A
Transmitter section						
SUMMING AMPLIFIER						
$V_{o(p-p)}$	pin MODO output voltage (peak-to-peak value)		–	94	240	mV
R_{fb}	external feedback resistor	between pins MODI and MODO	10	–	–	k Ω
V_{bias}	pin MODI bias voltage		–	2.2	–	V

900 MHz analog cordless telephone IC

UAA3515A

SYMBOL	PARAMETER	CONDITIONS	MIN.	TYP.	MAX.	UNIT
TX VOLTAGE-CONTROLLED OSCILLATOR AND POWER AMPLIFIER						
$f_{VCO(TX)}$	VCO free running frequency	note 1	–	910	–	MHz
$Q_{L(VCO)(TX)}$	quality factor of external inductor	$L = 3.9 \text{ nH}$; $f_{VCO} = 902 \text{ to } 928 \text{ MHz}$	30	–	–	
$\frac{\Delta f_{VCO(TX)}}{\Delta V_{TXLF}}$	VCO gain	$V_{TXLF} = 0.5 \text{ V}$	–	50	–	MHz/V
		$V_{TXLF} = 1.5 \text{ V}$	–	25	–	MHz/V
$\frac{\Delta f_{VCO(TX)}}{\Delta V_{mod}}$	VCO modulation gain	$V_{MOD0} = 2.2\text{V}$	–	530	–	kHz/V
$N_{VCO(TX)}$	VCO and power amplifier phase noise	$P_o = 0 \text{ dBm}$; $f_{carrier} = 925.6 \text{ MHz}$; TX to RX duplexer isolation is 35 dB minimum; $L_{ext} = 3.9 \text{ nH}$ (both base and handset); loop filter: see note 4 $f_{offset} = 20 \text{ MHz}$ $f_{offset} = 10 \text{ kHz}$ $f_{offset} = 1 \text{ kHz}$	–139 – –	–150 –85 –60	– – –	 dBc/Hz dBc/Hz dBc/Hz
$P_{o(PA)}$	PA output power range	$R_o = 50 \Omega$, $L_p = 22 \text{ nH}$; $C_s = 1.6 \text{ pF}$ (see Fig.4)	–	2	–	dB
$\Delta P_{o(PA)}$	PA output power adjustment		–	4	–	steps
$P_{o(PA)(max)}$	PA maximum output power	$R_o = 50 \Omega$, $L_p = 22 \text{ nH}$, $C_s = 1.6 \text{ pF}$ (see Fig.4); remove duplexer insertion loss to get power on the antenna	–	1	–	dBm
TRANSMIT SYSTEM						
THD_{TX}	total harmonic distortion after demodulation	$f_{dev} = \pm 60 \text{ kHz}$; $V_{MOD0} = 225 \text{ mV (p-p)}$; CCITT filter included	–	1	2	%
$\alpha_{ct(RX-TX)}$	RXVCO crosstalk on PA output with respect to output power	note 1	–	–45	–	dBc
Synthesizer						
CRYSTAL OSCILLATOR: external capacitor on pin XTALO is 8.2 pF; on pin XTALI is 5.6 pF (indicative)						
$f_{(i)XTAL}$	crystal input frequency		4	10.24	20	MHz
C_{XTALI}	input capacitance on pin XTALI	indicative; XTAL tuning cap = 8 (see Table 5)	–	4	–	pF
C_{XTALO}	input capacitance on pin XTALO	indicative	–	1.5	–	pF
ΔC_{TUNE}	crystal tuning capacitance range	on XTALI pin	–	4.5	–	pF

900 MHz analog cordless telephone IC

UAA3515A

SYMBOL	PARAMETER	CONDITIONS	MIN.	TYP.	MAX.	UNIT
N _{TUNE}	number of capacitance tuning steps		–	16	–	steps
REFERENCE AND CLOCK DIVIDER						
RDR	reference divider ratio		8	–	1023	
CDR	clock divider ratio	5 steps (2, 2.5, 4, 1 and 128)	1	–	128	
C _{L(CLKOUT)}	clock output load capacitance	external to pin CLKOUT	–	–	20	pF
V _{CLKOUT(p-p)}	CLKOUT voltage swing (peak-to-peak value)	CLKO level = 0	–	1.4	–	V
		CLKO level = 1	–	1	–	V
t _{sw(f1-f2)}	switching time from frequency f1 to f2		–	$\frac{2}{f_2}$	–	s
RF TX AND RX PRESCALER AND MAIN DIVIDERS						
f _{RF}	RF input frequency		902	903	928	MHz
R _{PDR}	prescaler divider ratio		64	–	127	
R _{MDR}	main divider ratio		8	–	1023	
<i>Charge pump current</i>						
I _{RXCPSink}	RX charge pump sink current	RXCPI = 0	–	400	–	μA
		RXCPI = 1	–	800	–	μA
I _{RXCPSource}	RX charge pump source current	RXCPI = 0	–	–400	–	μA
		RXCPI = 1	–	–800	–	μA
I _{TXCPSink}	TX charge pump sink current	TXCPI = 0	–	400	–	μA
		TXCPI = 1	–	800	–	μA
I _{TXCPSource}	TX charge pump source current	TXCPI = 0	–	–400	–	μA
		TXCPI = 1	–	–800	–	μA
RX VCO						
f _{VCO}	oscillator free running frequency	note 1	–	910	–	MHz
Q _{L(VCO)(RX)}	external inductor quality factor	f = 920 MHz; L = 3.9 nH	30	–	–	
$\frac{\Delta f_{VCO(RX)}}{\Delta V_{RXLF}}$	VCO gain	L _{ext} = 4.7 nH at 890 MHz (3.9 nH for 935 MHz operation)	–	55	–	MHz/V
		V _{RXLF} = 0.5 V V _{RXLF} = 1.5 V	–	30	–	MHz/V
N _{VCO(RX)}	VCO RX phase noise; (indicative: cannot be measured directly)	f _{carrier} = 892.3 MHz; L _{ext} = 4.7 nH (3.9 nH for 935 MHz operation); loop filter: see note 5	–	–58	–	dBc/Hz
		f _{offset} = 1 kHz	–	–82	–	dBc/Hz
		f _{offset} = 100 kHz	–	–102	–	dBc/Hz

900 MHz analog cordless telephone IC

UAA3515A

SYMBOL	PARAMETER	CONDITIONS	MIN.	TYP.	MAX.	UNIT
VOLTAGE DOUBLER (Doubler enable = 1)						
$V_{CC(CP)}$	charge pump supply voltage from voltage doubler	$V_{CC} = 3\text{ V}$	–	5.2	–	V
$I_{CC(CP)}$	voltage doubler current consumption	PLL locked	–	300	–	μA
		RX or TX mode CDR = 128	–	130	–	μA
RX baseband						
RX AUDIO PATH (see Fig.6): $V_{VB} = 1.5\text{ V}$; $f_{\text{mod}} = 1\text{ kHz}$; RX gain set for 0 dB at $V_{i(\text{RXAI})} = -20\text{ dBV}$; earpiece amplifier gain set by VCTL to 4.7 dB; with no external resistor and $C_{\text{ext}} = 560\text{ pF}$; measured with a CCITT filter, except THD; $Z_{L(\text{EARO})} = 150\ \Omega$ in series with $10\ \mu\text{F}$						
ΔG_{RX}	RX gain adjustment range	on RX gain amplifier	-7.5	–	+8	dB
		on EARO	-15	–	+16	dB
$\Delta G_{\text{RX(steps)}}$	RX gain adjustment steps	programmable through microcontroller interface	–	32	–	steps
$\Delta G_{\text{RX(mute)}}$	RX gain with mute on	$V_{i(\text{RXAI})} = -20\text{ dBV}$	–	-70	-60	dB
G_{EXP}	expander gain	$V_{i(\text{RXAI})} = -20\text{ dBV}$	-1	0	+1	dB
		$V_{i(\text{RXAI})} = -30\text{ dBV}$	-22	-20	-18	dB
		$V_{i(\text{RXAI})} = -35\text{ dBV}$	-34	-30	-26	dB
$V_{i(\text{RXAI})(\text{max})}$	maximum input voltage	THD < 4%	–	-13	–	dBV
$V_{o(\text{EXP})(\text{max})}$	maximum expander output voltage (indicative; cannot be measured directly)	indicative; THD < 4%	–	-7	–	dBV
N_{RX}	RX audio path noise	BW = 300 Hz to 3.4 kHz	–	-83	–	dBVp
$Z_{i(\text{RXAI})}$	input impedance	note 3	–	15	–	k Ω
		TX mode	–	15	–	k Ω
		RX mode	100	–	–	k Ω
$t_{\text{att(EXP)}}$	expander attack time	$C_{\text{ECAP}} = 0.47\ \mu\text{F}$	–	2.0	–	ms
$t_{\text{rel(EXP)}}$	expander release time	$C_{\text{ECAP}} = 0.47\ \mu\text{F}$	–	5.0	–	ms
$\alpha_{\text{ct(TX-RX)}}$	TX compressor to RX expander crosstalk attenuation	measured between pins CMPI and EARO; $V_{\text{RXAI}} = 0$; $V_{\text{CMPI}} = -20\text{ dBV}$	–	80	–	dB
$V_{\text{EARO}(\text{max})(\text{p-p})}$	maximum output voltage (peak-peak value)	THD < 4%	–	2.2	–	V
$R_{L(\text{EARO})}$	load resistance on pin EARO for stable earpiece amplifier	in series with $10\ \mu\text{F}$ capacitor	–	0.15	100	k Ω
G_{EAR}	earpiece amplifier gain set by internal resistors without external components (R_{ext} and C_{ext})	$R_{\text{int}} = 14\text{ k}\Omega$	-1	0	+1	dB
		$R_{\text{int}} = 24\text{ k}\Omega$	3.7	4.7	5.7	dB
		$R_{\text{int}} = 41\text{ k}\Omega$	8.3	9.3	10.3	dB
		$R_{\text{int}} = 70.2\text{ k}\Omega$	13	14	15	dB

900 MHz analog cordless telephone IC

UAA3515A

SYMBOL	PARAMETER	CONDITIONS	MIN.	TYP.	MAX.	UNIT
$G_{\text{EAR(dyn)}}$	dynamic earpiece amplifier gain		13	14	15	dB
THD_{ARX}	audio receiver total harmonic distortion	$V_{i(\text{RXAI})} = -20 \text{ dBV}$	–	0.2	2	%
TX baseband						
MICROPHONE AMPLIFIER: $V_{\text{VB}} = 1.5 \text{ V}$; $f_{\text{mod}} = 1 \text{ kHz}$						
$V_{\text{MICO(max)}}$	maximum output voltage	$R_{\text{L}} = 10 \text{ k}\Omega$; $\text{THD} < 4\%$	–12	–	–	dBV
ΔG_{V}	voltage gain range		0	–	34	dB
TX AUDIO PATH (see Fig.8): $V_{\text{VB}} = 1.5 \text{ V}$; $f_{\text{mod}} = 1 \text{ kHz}$; TX gain set for 10 dB at $V_{\text{CMPI}} = -30 \text{ dBV}$						
G_{COMP}	compressor gain level	ALC disable = 1; hard limiter enable = 0	9	10	11	dB
ΔG_{COMP}	change in compressor gain referenced to $V_{\text{CMPI}} = -30 \text{ dBV}$	$V_{\text{CMPI}} = -10 \text{ dBV}$	8	10	12	dB
		$V_{\text{CMPI}} = -50 \text{ dBV}$	–12	–10	–8	dB
$G_{\text{COMP(max)}}$	maximum compressor gain	$V_{\text{CMPI}} = -70 \text{ dBV}$	–	23	–	dB
$V_{\text{HLIM(p-p)}}$	hard limiter output voltage (peak-to-peak value)	ALC disable = 1; hard limiter enable = 1; $V_{\text{CMPI}} = -4 \text{ dBV}$	–	1.26	–	V
$V_{\text{TXO(max)}}$	maximum output voltage range	ALC disable = 0	–	–	–	–
		$V_{\text{CMPI}} = -12 \text{ dBV}$	–	–12.5	–	dBV
		$V_{\text{CMPI}} = -10 \text{ dBV}$	–	–12.3	–	dBV
$V_{\text{CMPI}} = -2.5 \text{ dBV}$	–	–11.5	–	dBV		
THD_{COMP}	compressor total harmonic distortion	ALC disable = 1; $V_{\text{CMPI}} = -10 \text{ dBV}$	–	0.3	1	%
Z_{CMPI}	input impedance on pin CMPI		–	15	–	k Ω
$t_{\text{att(COMP)}}$	compressor attack time	$C_{\text{CCAP}} = 0.47 \mu\text{F}$	–	4.0	–	ms
$t_{\text{rel(COMP)}}$	compressor release time	$C_{\text{CCAP}} = 0.47 \mu\text{F}$	–	8.0	–	ms
$\alpha_{\text{ct(RX-TX)}}$	RX expander to TX compressor crosstalk attenuation	measured between pins RXAI and TXO; $V_{\text{CMPI}} = 0$; $V_{\text{RXAI}} = -10 \text{ dBV}$	–	65	–	dB
ΔG_{TX}	TX gain adjustment range	programmable through microcontroller interface	–7.5	–	+8	dB
$\Delta G_{\text{TX(steps)}}$	TX gain adjustment steps	programmable through microcontroller interface	–	32	–	steps
$\Delta G_{\text{TX(mute)}}$	TX gain with mute on	ALC disable = 1; $V_{\text{CMPI}} = -10 \text{ dBV}$	–	–70	–60	dB
$Z_{\text{o(TXO)}}$	output impedance at pin TXO		–	500	–	Ω

900 MHz analog cordless telephone IC

UAA3515A

SYMBOL	PARAMETER	CONDITIONS	MIN.	TYP.	MAX.	UNIT
Microcontroller interface						
DC CHARACTERISTICS FOR DIGITAL PINS						
V _{IL}	LOW-level input voltage	serial interface	–	–	0.5	V
V _{IH}	HIGH-level input voltage	serial interface	$\frac{V_{VREG}}{1.5}$	–	V _{CC}	V
I _{IL}	LOW-level input current	serial interface; V _{IL} = 0.3 V	–5	–	–	μA
I _{IH}	HIGH-level input current	serial interface; V _{IH} = V _{REG} – 0.3 V	–	–	5	μA
I _{OL}	LOW-level output current	pin CDLBD	20	–	–	μA
V _{OL}	LOW-level output voltage	pin CDLBD; R _L = 470 kΩ	–	–	0.1V _{CC}	V
V _{OH}	HIGH-level output voltage	pin CDLBD; R _L = 470 kΩ	0.9V _{CC}	–	–	V
C _i	input capacitance	serial bus	–	–	8	pF
C _o	output capacitance	pins RXPd and TXPD	–	–	8	pF
SERIAL INTERFACE TIMING; CLK, DATA and EN (see Fig.10)						
t _{su(CLK-EN)}	clock to enable set-up time	50% signal level	50	–	–	ns
t _{su(DATA-CLK)}	input data to clock set-up time	50% signal level	50	–	–	ns
t _{h(EN-CLK)}	enable to clock hold time	50% signal level	50	–	–	ns
f _{CLK}	clock frequency		–	–	3	MHz
t _r	input rise time	10% to 90%	–	–	50	ns
t _f	input fall time	10% to 90%	–	–	50	ns
t _{END}	delay from last falling clock edge		100	–	–	ns
t _w	enable pulse width	see Fig.10	$\frac{1}{f_{comp}}$	–	–	ns
t _{strt}	microcontroller interface start-up time	90% of V _{VREG} to DATA, CLK and EN present	–	–	200	μs

Notes

1. Measured and guaranteed only on the Philips UAA3515A test board.
2. Loop filter: C₁ = 1.8 nF; R₂ = 4.7 kΩ; C₂ = 150 nF (see "Report CTT01001", available on request).
3. RXAI level will be higher in RX mode than in TX mode.
4. Loop filter: C₁ = 3.9 nF; R₂ = 6.8 kΩ; C₂ = 47 nF (see "Report CTT01001", available on request).
5. Loop filter: C₁ = 470 nF; R₂ = 1.8 kΩ; C₂ = 4.7 μF (see "Report CTT01001", available on request).

900 MHz analog cordless telephone IC

UAA3515A

12 PACKAGE OUTLINE

LQFP64: plastic low profile quad flat package; 64 leads; body 10 x 10 x 1.4 mm

SOT314-2



DIMENSIONS (mm are the original dimensions)

UNIT	A max.	A ₁	A ₂	A ₃	b _p	c	D ⁽¹⁾	E ⁽¹⁾	e	H _D	H _E	L	L _p	v	w	y	Z _D ⁽¹⁾	Z _E ⁽¹⁾	θ
mm	1.60	0.20 0.05	1.45 1.35	0.25	0.27 0.17	0.18 0.12	10.1 9.9	10.1 9.9	0.5	12.15 11.85	12.15 11.85	1.0	0.75 0.45	0.2	0.12	0.1	1.45 1.05	1.45 1.05	7° 0°

Note

1. Plastic or metal protrusions of 0.25 mm maximum per side are not included.

OUTLINE VERSION	REFERENCES				EUROPEAN PROJECTION	ISSUE DATE
	IEC	JEDEC	EIAJ			
SOT314-2	136E10	MS-026				99-12-27 00-01-19

900 MHz analog cordless telephone IC

UAA3515A

13 SOLDERING**13.1 Introduction to soldering surface mount packages**

This text gives a very brief insight to a complex technology. A more in-depth account of soldering ICs can be found in our *"Data Handbook IC26; Integrated Circuit Packages"* (document order number 9398 652 90011).

There is no soldering method that is ideal for all surface mount IC packages. Wave soldering can still be used for certain surface mount ICs, but it is not suitable for fine pitch SMDs. In these situations reflow soldering is recommended.

13.2 Reflow soldering

Reflow soldering requires solder paste (a suspension of fine solder particles, flux and binding agent) to be applied to the printed-circuit board by screen printing, stencilling or pressure-syringe dispensing before package placement.

Several methods exist for reflowing; for example, convection or convection/infrared heating in a conveyor type oven. Throughput times (preheating, soldering and cooling) vary between 100 and 200 seconds depending on heating method.

Typical reflow peak temperatures range from 215 to 250 °C. The top-surface temperature of the packages should preferably be kept below 220 °C for thick/large packages, and below 235 °C for small/thin packages.

13.3 Wave soldering

Conventional single wave soldering is not recommended for surface mount devices (SMDs) or printed-circuit boards with a high component density, as solder bridging and non-wetting can present major problems.

To overcome these problems the double-wave soldering method was specifically developed.

If wave soldering is used the following conditions must be observed for optimal results:

- Use a double-wave soldering method comprising a turbulent wave with high upward pressure followed by a smooth laminar wave.
- For packages with leads on two sides and a pitch (e):
 - larger than or equal to 1.27 mm, the footprint longitudinal axis is **preferred** to be parallel to the transport direction of the printed-circuit board;
 - smaller than 1.27 mm, the footprint longitudinal axis **must** be parallel to the transport direction of the printed-circuit board.

The footprint must incorporate solder thieves at the downstream end.
- For packages with leads on four sides, the footprint must be placed at a 45° angle to the transport direction of the printed-circuit board. The footprint must incorporate solder thieves downstream and at the side corners.

During placement and before soldering, the package must be fixed with a droplet of adhesive. The adhesive can be applied by screen printing, pin transfer or syringe dispensing. The package can be soldered after the adhesive is cured.

Typical dwell time is 4 seconds at 250 °C.

A mildly-activated flux will eliminate the need for removal of corrosive residues in most applications.

13.4 Manual soldering

Fix the component by first soldering two diagonally-opposite end leads. Use a low voltage (24 V or less) soldering iron applied to the flat part of the lead. Contact time must be limited to 10 seconds at up to 300 °C.

When using a dedicated tool, all other leads can be soldered in one operation within 2 to 5 seconds between 270 and 320 °C.

900 MHz analog cordless telephone IC

UAA3515A

13.5 Suitability of surface mount IC packages for wave and reflow soldering methods

PACKAGE	SOLDERING METHOD	
	WAVE	REFLOW ⁽¹⁾
BGA, HBGA, LFBGA, SQFP, TFBGA	not suitable	suitable
HBCC, HLQFP, HSQFP, HSOP, HTQFP, HTSSOP, HVQFN, SMS	not suitable ⁽²⁾	suitable
PLCC ⁽³⁾ , SO, SOJ	suitable	suitable
LQFP, QFP, TQFP	not recommended ⁽³⁾⁽⁴⁾	suitable
SSOP, TSSOP, VSO	not recommended ⁽⁵⁾	suitable

Notes

1. All surface mount (SMD) packages are moisture sensitive. Depending upon the moisture content, the maximum temperature (with respect to time) and body size of the package, there is a risk that internal or external package cracks may occur due to vaporization of the moisture in them (the so called popcorn effect). For details, refer to the Drypack information in the *"Data Handbook IC26; Integrated Circuit Packages; Section: Packing Methods"*.
2. These packages are not suitable for wave soldering as a solder joint between the printed-circuit board and heatsink (at bottom version) can not be achieved, and as solder may stick to the heatsink (on top version).
3. If wave soldering is considered, then the package must be placed at a 45° angle to the solder wave direction. The package footprint must incorporate solder thieves downstream and at the side corners.
4. Wave soldering is only suitable for LQFP, TQFP and QFP packages with a pitch (e) equal to or larger than 0.8 mm; it is definitely not suitable for packages with a pitch (e) equal to or smaller than 0.65 mm.
5. Wave soldering is only suitable for SSOP and TSSOP packages with a pitch (e) equal to or larger than 0.65 mm; it is definitely not suitable for packages with a pitch (e) equal to or smaller than 0.5 mm.

900 MHz analog cordless telephone IC

UAA3515A

14 DATA SHEET STATUS

DATA SHEET STATUS ⁽¹⁾	PRODUCT STATUS ⁽²⁾	DEFINITIONS
Objective data	Development	This data sheet contains data from the objective specification for product development. Philips Semiconductors reserves the right to change the specification in any manner without notice.
Preliminary data	Qualification	This data sheet contains data from the preliminary specification. Supplementary data will be published at a later date. Philips Semiconductors reserves the right to change the specification without notice, in order to improve the design and supply the best possible product.
Product data	Production	This data sheet contains data from the product specification. Philips Semiconductors reserves the right to make changes at any time in order to improve the design, manufacturing and supply. Changes will be communicated according to the Customer Product/Process Change Notification (CPCN) procedure SNW-SQ-650A.

Notes

1. Please consult the most recently issued data sheet before initiating or completing a design.
2. The product status of the device(s) described in this data sheet may have changed since this data sheet was published. The latest information is available on the Internet at URL <http://www.semiconductors.philips.com>.

15 DEFINITIONS

Short-form specification — The data in a short-form specification is extracted from a full data sheet with the same type number and title. For detailed information see the relevant data sheet or data handbook.

Limiting values definition — Limiting values given are in accordance with the Absolute Maximum Rating System (IEC 60134). Stress above one or more of the limiting values may cause permanent damage to the device. These are stress ratings only and operation of the device at these or at any other conditions above those given in the Characteristics sections of the specification is not implied. Exposure to limiting values for extended periods may affect device reliability.

Application information — Applications that are described herein for any of these products are for illustrative purposes only. Philips Semiconductors make no representation or warranty that such applications will be suitable for the specified use without further testing or modification.

16 DISCLAIMERS

Life support applications — These products are not designed for use in life support appliances, devices, or systems where malfunction of these products can reasonably be expected to result in personal injury. Philips Semiconductors customers using or selling these products for use in such applications do so at their own risk and agree to fully indemnify Philips Semiconductors for any damages resulting from such application.

Right to make changes — Philips Semiconductors reserves the right to make changes, without notice, in the products, including circuits, standard cells, and/or software, described or contained herein in order to improve design and/or performance. Philips Semiconductors assumes no responsibility or liability for the use of any of these products, conveys no licence or title under any patent, copyright, or mask work right to these products, and makes no representations or warranties that these products are free from patent, copyright, or mask work right infringement, unless otherwise specified.

900 MHz analog cordless telephone IC

UAA3515A

NOTES

900 MHz analog cordless telephone IC

UAA3515A

NOTES

900 MHz analog cordless telephone IC

UAA3515A

NOTES

Philips Semiconductors – a worldwide company

Contact information

For additional information please visit <http://www.semiconductors.philips.com>. Fax: +31 40 27 24825

For sales offices addresses send e-mail to: sales.addresses@www.semiconductors.philips.com.

© Koninklijke Philips Electronics N.V. 2001

SCA73

All rights are reserved. Reproduction in whole or in part is prohibited without the prior written consent of the copyright owner.

The information presented in this document does not form part of any quotation or contract, is believed to be accurate and reliable and may be changed without notice. No liability will be accepted by the publisher for any consequence of its use. Publication thereof does not convey nor imply any license under patent- or other industrial or intellectual property rights.

Printed in The Netherlands

403506/01/pp44

Date of release: 2001 Dec 12

Document order number: 9397 750 08997

Let's make things better.

**Philips
Semiconductors**



PHILIPS