

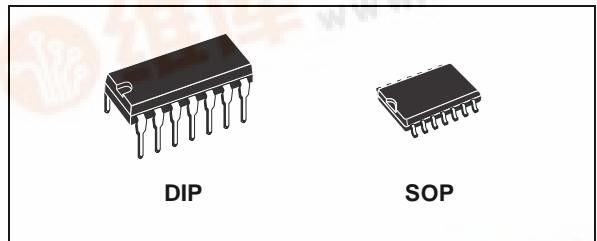

HCF4041UB

QUAD TRUE/COMPLEMENT BUFFER

- BALANCED SINK AND SOURCE CURRENT: APPROXIMATELY 4 TIMES STANDARD "B" DRIVE
- EQUALIZED DELAY TO TRUE AND COMPLEMENT OUTPUTS
- QUIESCENT CURRENT SPECIFIED UP TO 20V
- STANDARDIZED SYMMETRICAL OUTPUT CHARACTERISTICS
- 5V, 10V AND 15V PARAMETRIC RATINGS
- INPUT LEAKAGE CURRENT
 $I_l = 100\text{nA}$ (MAX) AT $V_{DD} = 18\text{V}$ $T_A = 25^\circ\text{C}$
- 100% TESTED FOR QUIESCENT CURRENT
- MEETS ALL REQUIREMENTS OF JEDEC JESD13B "STANDARD SPECIFICATIONS FOR DESCRIPTION OF B SERIES CMOS DEVICES"



ORDER CODES

PACKAGE	TUBE	T & R
DIP	HCF4041UBEY	
SOP	HCF4041UBM1	HCF4041UM013TR

DESCRIPTION

The HCF4041UB is a monolithic integrated circuit fabricated in Metal Oxide Semiconductor technology available in DIP and SOP packages. The HCF4041UB is a QUAD TRUE/COMPLEMENT buffer consisting of n and p channel units having low channel resistance and

high current (sourcing and sinking) capability. This device is intended for use as a buffer, line driver, or CMOS to TTL driver. It can be used as an ultra-low power resistor network driver for A/D and D/A conversion, as a transmission line driver, and in other applications where high noise immunity and low power dissipation are primary design requirements.

PIN CONNECTION

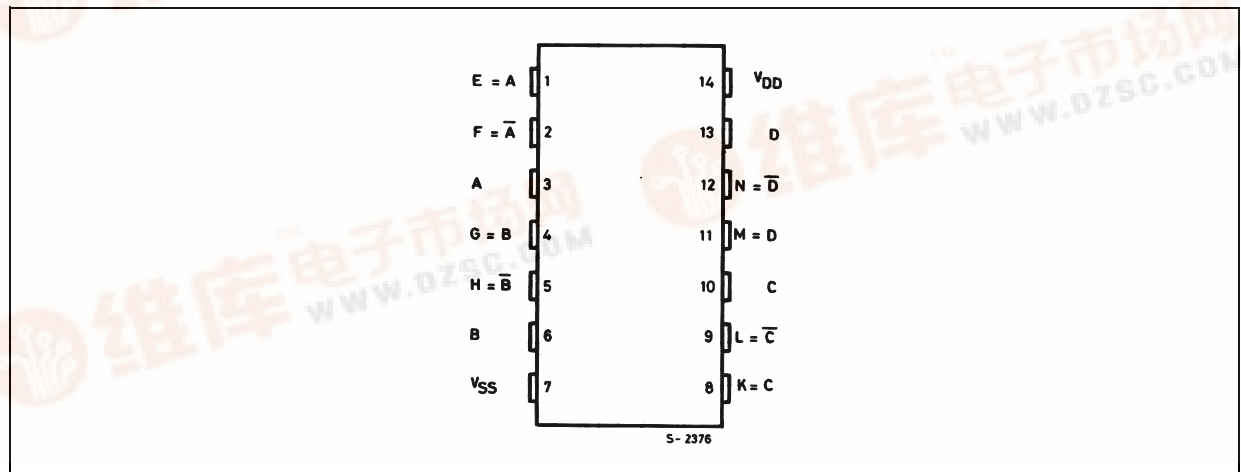

HCF4041UB

INPUT EQUIVALENT CIRCUIT

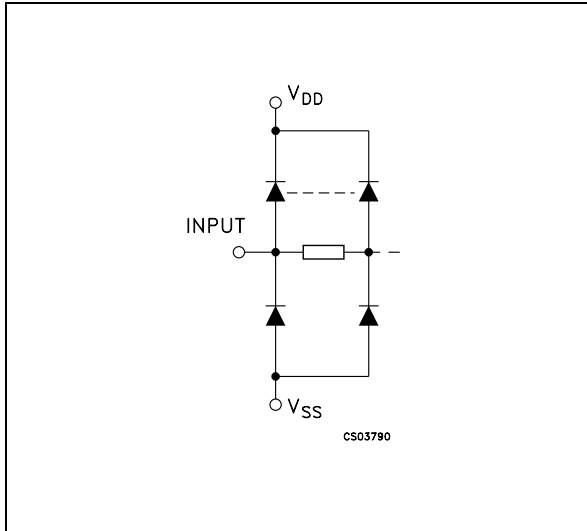

PIN DESCRIPTION

PIN No	SYMBOL	NAME AND FUNCTION
3, 6, 10, 13	A, B, C, D	Data Inputs
1, 4, 8, 11	E, G, K, M	Data Outputs (TRUE)
2, 5, 9, 12	F, H, L, N	Data Outputs (COMPLEMENT)
7	V_{SS}	Negative Supply Voltage
14	V_{DD}	Positive Supply Voltage

TRUTH TABLE

INPUTS	OUTPUTS (TRUE)	OUTPUTS (COMPLEMENT)
A, B, C, D	E, G, K, M	F, H, L, N
H	H	L
L	L	H

FUNCTIONAL DIAGRAM

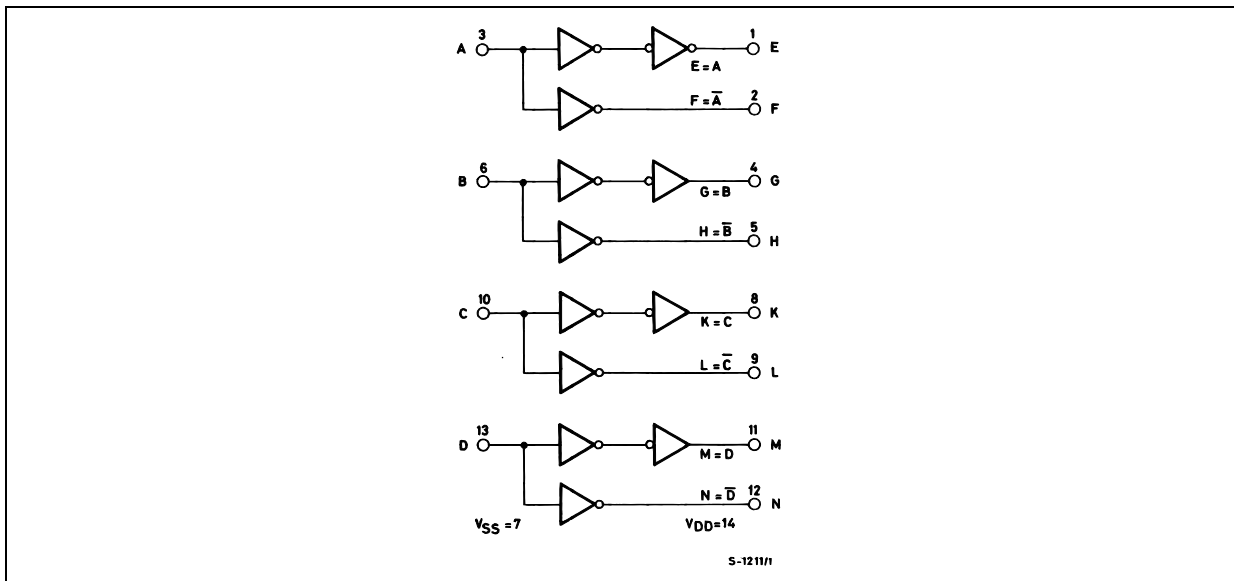

ABSOLUTE MAXIMUM RATINGS

Symbol	Parameter	Value	Unit
V_{DD}	Supply Voltage	-0.5 to +22	V
V_I	DC Input Voltage	-0.5 to $V_{DD} + 0.5$	V
I_I	DC Input Current	± 10	mA
P_D	Power Dissipation per Package	200	mW
	Power Dissipation per Output Transistor	100	mW
T_{op}	Operating Temperature	-55 to +125	$^{\circ}C$
T_{stg}	Storage Temperature	-65 to +150	$^{\circ}C$

Absolute Maximum Ratings are those values beyond which damage to the device may occur. Functional operation under these conditions is not implied. All voltage values are referred to V_{SS} pin voltage.

RECOMMENDED OPERATING CONDITIONS

Symbol	Parameter	Value	Unit
V _{DD}	Supply Voltage	3 to 20	V
V _I	Input Voltage	0 to V _{DD}	V
T _{op}	Operating Temperature	-55 to 125	°C

DC SPECIFICATIONS

Symbol	Parameter	Test Condition				Value						Unit	
		V _I (V)	V _O (V)	I _{OL} (μ A)	V _{DD} (V)	T _A = 25°C			-40 to 85°C		-55 to 125°C		
						Min.	Typ.	Max.	Min.	Max.	Min.		Max.
I _L	Quiescent Current	0/5			5		0.02	1		30		30	μ A
		0/10			10		0.02	2		60		60	
		0/15			15		0.02	4		120		120	
		0/20			20		0.04	20		600		600	
V _{OH}	High Level Output Voltage	0/5		<1	5	4.95			4.95		4.95		V
		0/10		<1	10	9.95			9.95		9.95		
		0/15		<1	15	14.95			14.95		14.95		
V _{OL}	Low Level Output Voltage	5/0		<1	5		0.05			0.05		0.05	V
		10/0		<1	10		0.05			0.05		0.05	
		15/0		<1	15		0.05			0.05		0.05	
V _{IH}	High Level Input Voltage		0.5/4.5	<1	5	4			4		4		V
			1/9	<1	10	8			8		8		
			1.5/13.5	<1	15	12.5			12.5		12.5		
V _{IL}	Low Level Input Voltage		4.5/0.5	<1	5			1		1		1	V
			9/1	<1	10			2		2		2	
			13.5/1.5	<1	15			2.5		2.5		2.5	
I _{OH}	Output Drive Current	0/5	2.5	<1	5	-5.44	-12.8		-4.08		-4.08		mA
		0/5	4.6	<1	5	-1.36	-3.2		-1.02		-1.02		
		0/10	9.5	<1	10	-4.25	-10		-3.18		-3.18		
		0/15	13.5	<1	15	-16.1	-38		-12.1		-12.1		
I _{OL}	Output Sink Current	0/5	0.4	<1	5	1.36	3.2		1.02		1.02		mA
		0/10	0.5	<1	10	4.25	10		3.18		3.18		
		0/15	1.5	<1	15	16.1	38		12.11		12.11		
I _I	Input Leakage Current	0/18	Any Input		18		$\pm 10^{-5}$	± 0.1		± 1		± 1	μ A
C _I	Input Capacitance		Any Input				15	22.5					pF

The Noise Margin for both "1" and "0" level is: 1V min. with V_{DD}=5V, 2V min. with V_{DD}=10V, 2.5V min. with V_{DD}=15V

HCF4041UB

DYNAMIC ELECTRICAL CHARACTERISTICS ($T_{amb} = 25^{\circ}\text{C}$, $C_L = 50\text{pF}$, $R_L = 200\text{K}\Omega$, $t_r = t_f = 20\text{ ns}$)

Symbol	Parameter	Test Condition		Value (*)			Unit
		V_{DD} (V)		Min.	Typ.	Max.	
t_{PLH} t_{PHL}	Propagation Delay Time	5			60	120	ns
		10			35	70	
		15			25	50	
t_{TLH} t_{THL}	Output Transition Time	5			40	80	ns
		10			20	40	
		15			15	30	

(*) Typical temperature coefficient for all V_{DD} value is 0.3 %/°C.

TEST CIRCUIT

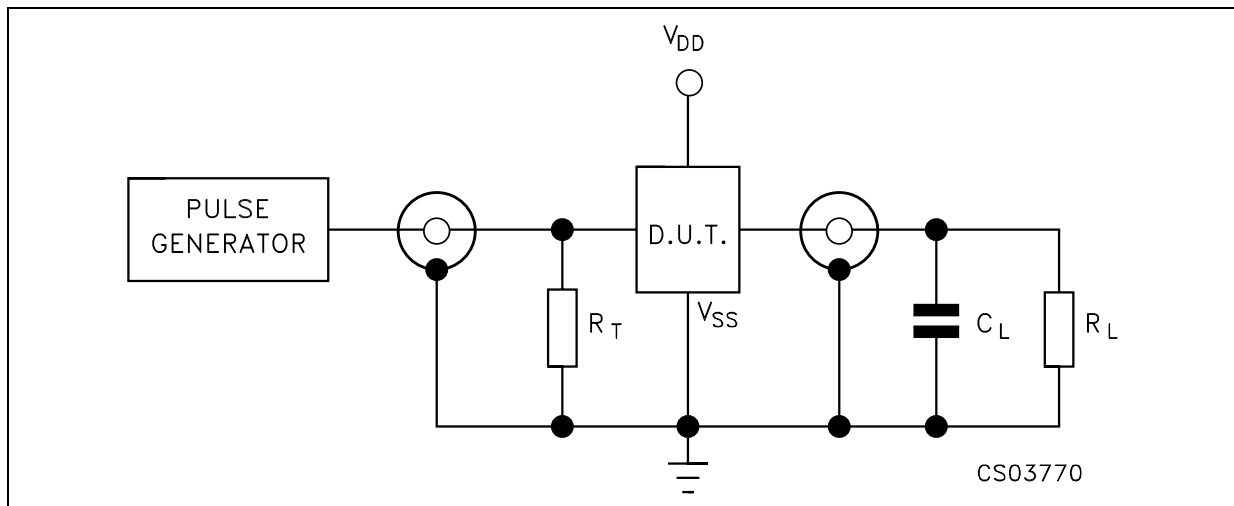

$C_L = 50\text{pF}$ or equivalent (includes jig and probe capacitance)

$R_L = 200\text{K}\Omega$

$R_T = Z_{OUT}$ of pulse generator (typically 50Ω)

WAVEFORM 1 : PROPAGATION DELAY TIMES FOR NON INVERTING CONDITIONS ($f=1\text{MHz}$; 50% duty cycle)

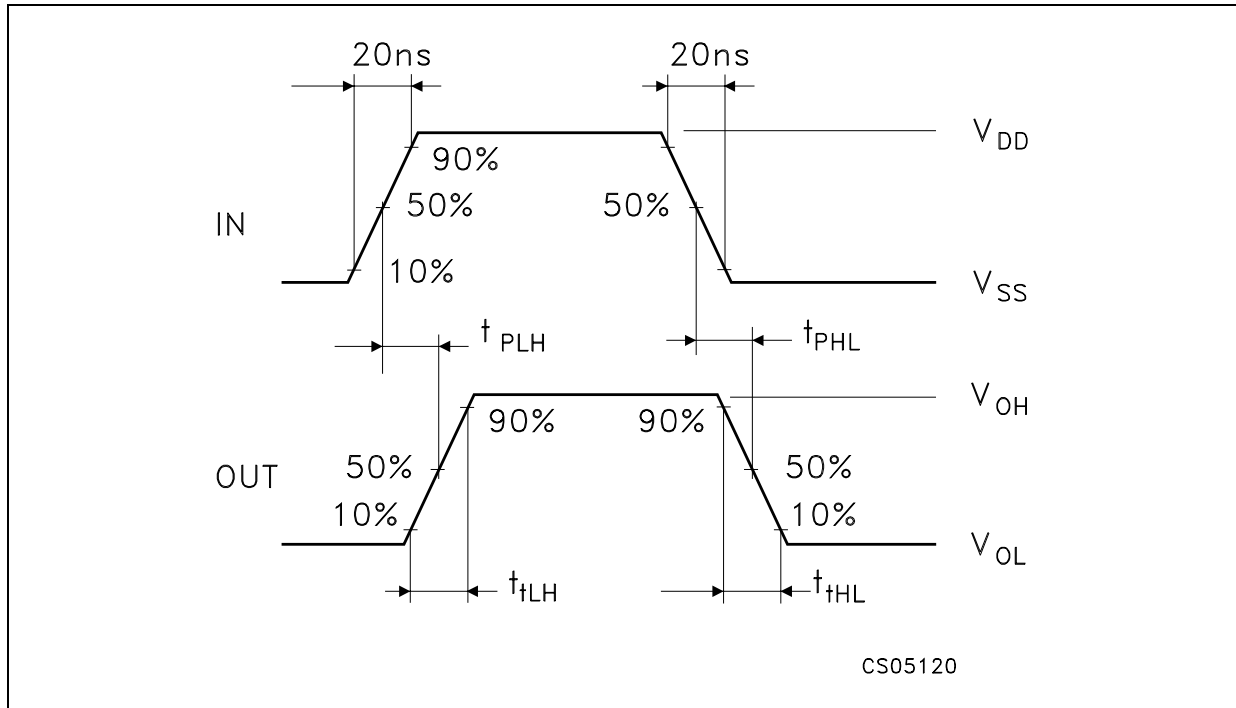

WAVEFORM 2 : PROPAGATION DELAY TIMES FOR INVERTING CONDITIONS ($f=1\text{MHz}$; 50% duty cycle)

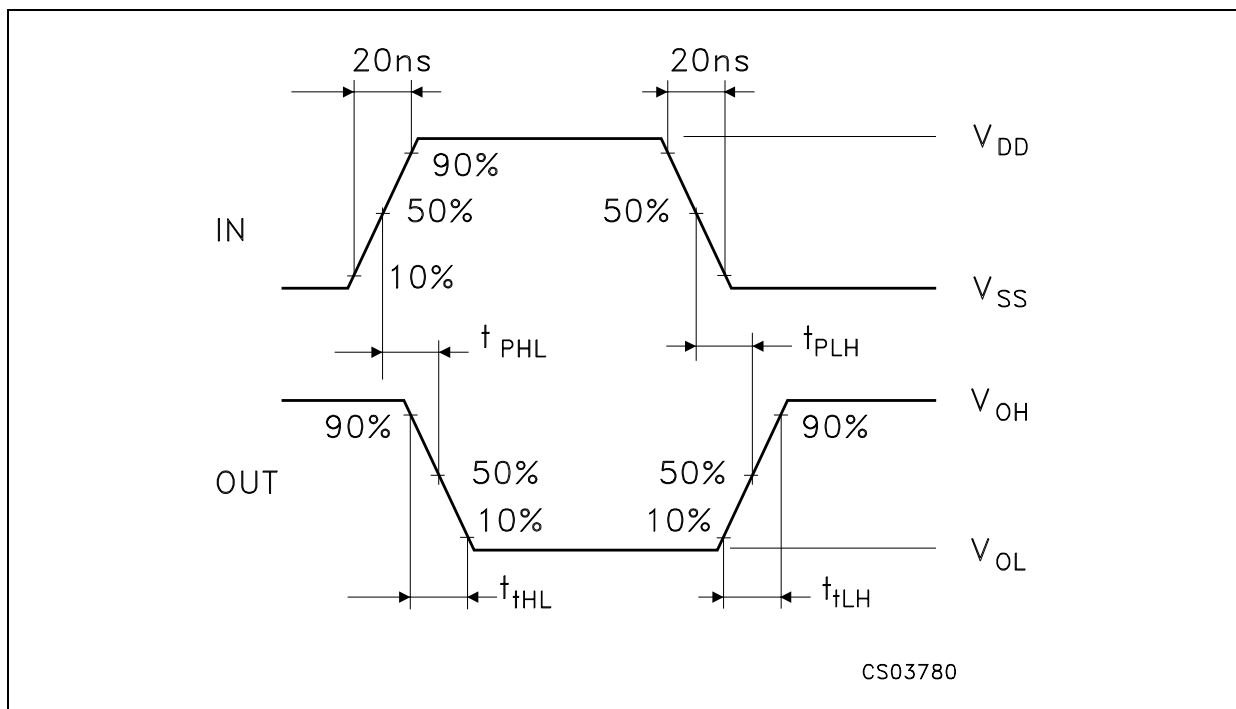

Plastic DIP-14 MECHANICAL DATA

DIM.	mm.			inch		
	MIN.	TYP.	MAX.	MIN.	TYP.	MAX.
a1	0.51			0.020		
B	1.39		1.65	0.055		0.065
b		0.5			0.020	
b1		0.25			0.010	
D			20			0.787
E		8.5			0.335	
e		2.54			0.100	
e3		15.24			0.600	
F			7.1			0.280
l			5.1			0.201
L		3.3			0.130	
Z	1.27		2.54	0.050		0.100

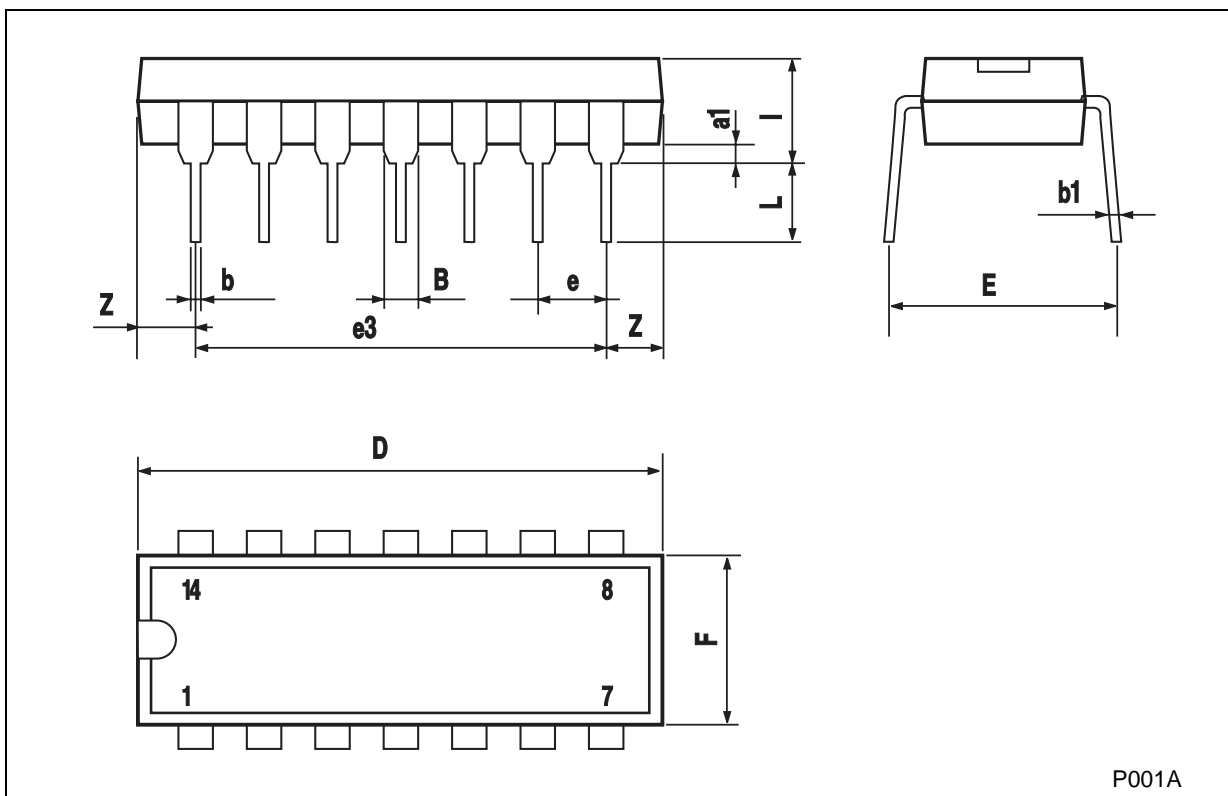

P001A

SO-14 MECHANICAL DATA

DIM.	mm.			inch		
	MIN.	TYP	MAX.	MIN.	TYP.	MAX.
A			1.75			0.068
a1	0.1		0.2	0.003		0.007
a2			1.65			0.064
b	0.35		0.46	0.013		0.018
b1	0.19		0.25	0.007		0.010
C		0.5			0.019	
c1	45° (typ.)					
D	8.55		8.75	0.336		0.344
E	5.8		6.2	0.228		0.244
e		1.27			0.050	
e3		7.62			0.300	
F	3.8		4.0	0.149		0.157
G	4.6		5.3	0.181		0.208
L	0.5		1.27	0.019		0.050
M			0.68			0.026
S	8° (max.)					

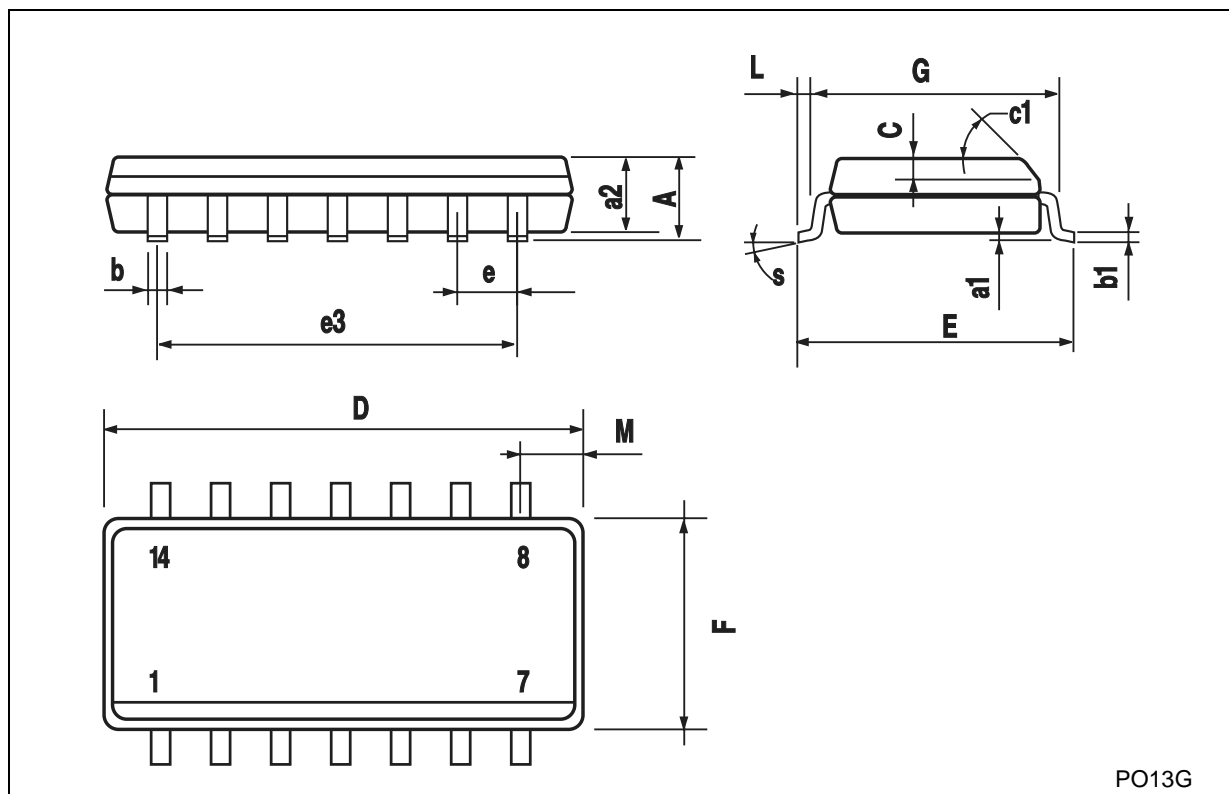

Information furnished is believed to be accurate and reliable. However, STMicroelectronics assumes no responsibility for the consequences of use of such information nor for any infringement of patents or other rights of third parties which may result from its use. No license is granted by implication or otherwise under any patent or patent rights of STMicroelectronics. Specifications mentioned in this publication are subject to change without notice. This publication supersedes and replaces all information previously supplied. STMicroelectronics products are not authorized for use as critical components in life support devices or systems without express written approval of STMicroelectronics.

© The ST logo is a registered trademark of STMicroelectronics

© 2001 STMicroelectronics - Printed in Italy - All Rights Reserved
STMicroelectronics GROUP OF COMPANIES

Australia - Brazil - China - Finland - France - Germany - Hong Kong - India - Italy - Japan - Malaysia - Malta - Morocco
Singapore - Spain - Sweden - Switzerland - United Kingdom

© <http://www.st.com>