



UC1517
UC3517

Stepper Motor Drive Circuit

FEATURES

- Complete Motor Driver and Encoder
- Continuous Drive Capability 350mA per Phase
- Contains all Required Logic for Full and Half Stepping
- Bilevel Operation for Fast Step Rates
- Operates as a Voltage Doubler
- Useable as a Phase Generator and/or as a Driver
- Power-On Reset Guarantees Safe, Predictable Power-Up

DESCRIPTION

The UC3517 contains four NPN drivers that operate in two-phase fashion for full-step and half-step motor control. The UC3517 also contains two emitter followers, two monostables, phase decoder logic, power-on reset, and low-voltage protection, making it a versatile system for driving small stepper motors or for controlling large power devices.

The emitter followers and monostables in the UC3517 are configured to apply higher-voltage pulses to the motor at each step command. This drive technique, called "Bilevel," allows faster stepping than common resistive current limiting, yet generates less electrical noise than chopping techniques.

ABSOLUTE MAXIMUM RATINGS

Second Level Supply, V _{SS}	40V	Power Dissipation, (Note)	2W
Phase Output Supply, V _{MM}	40V	Junction Temperature	150°C
Logic Supply, V _{CC}	7V	Ambient Temperature, UC1517	-55°C to +125°C
Logic Input Voltage	-3V to +7V	Ambient Temperature, UC3517	0°C to +70°C
Logic Input Current	±10mA	Storage Temperature	-55°C to +150°C
Output Current, Each Phase	500mA	<i>Note: Consult Packaging section of Databook for thermal limitations and considerations of package.</i>	
Output Current, Emitter Follower	-500mA		
Power Dissipation, (Note)	1W		

BLOCK DIAGRAM

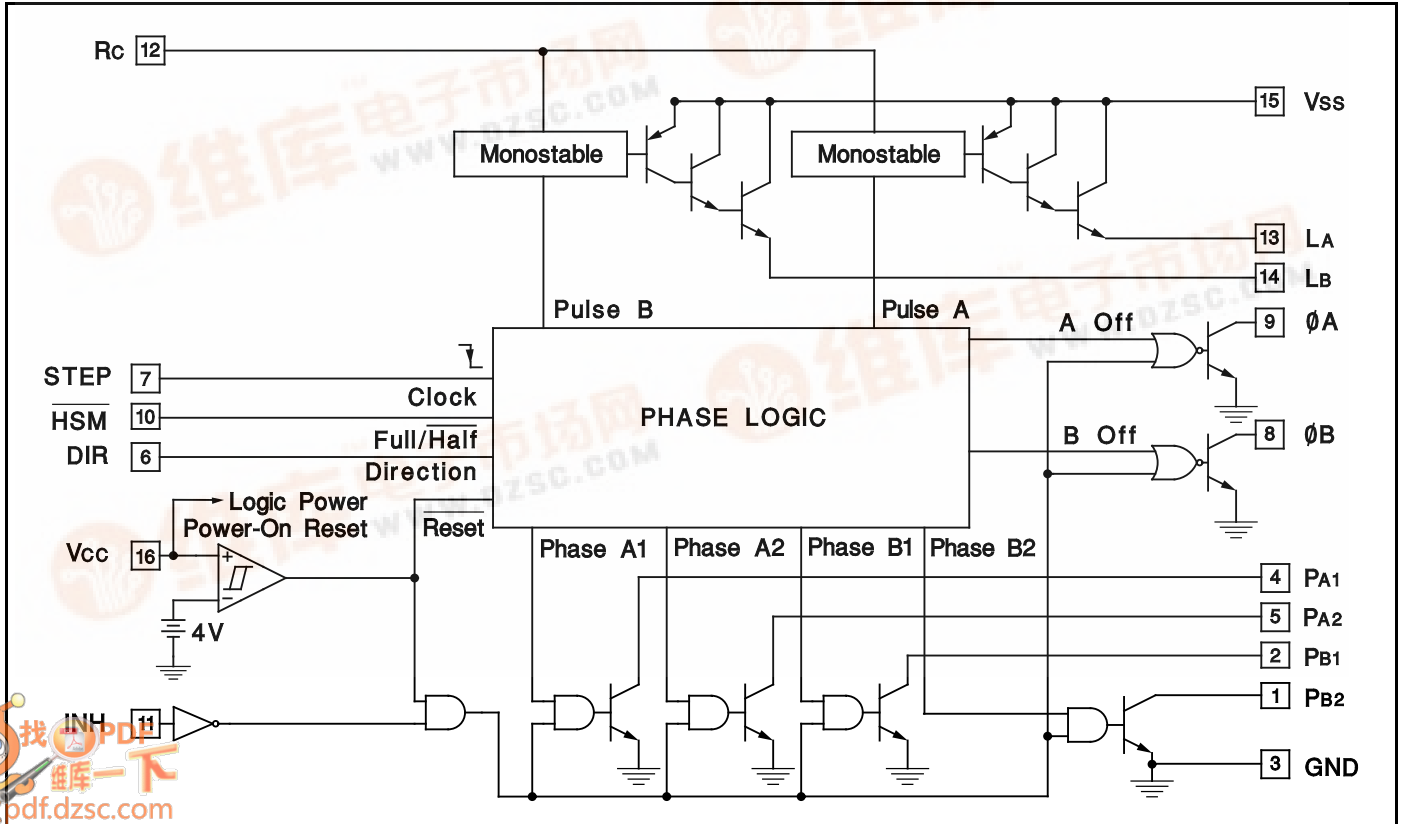

CONNECTION DIAGRAMS

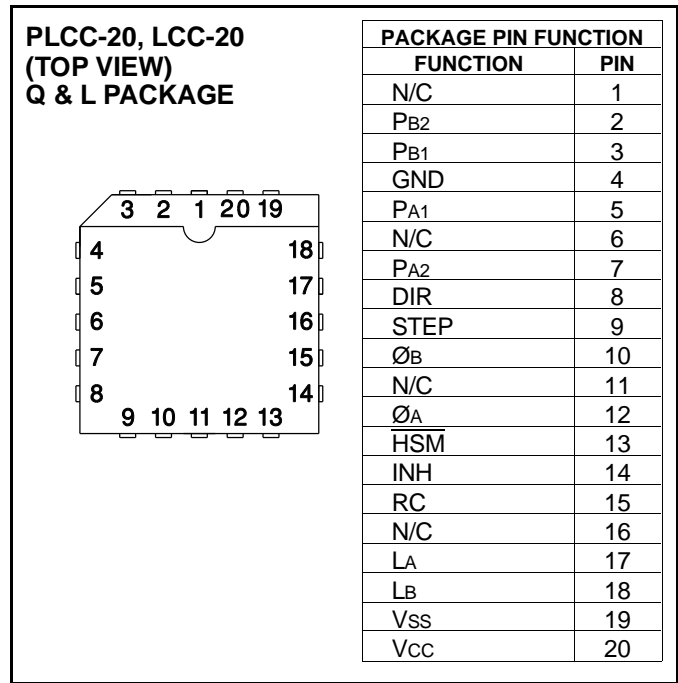
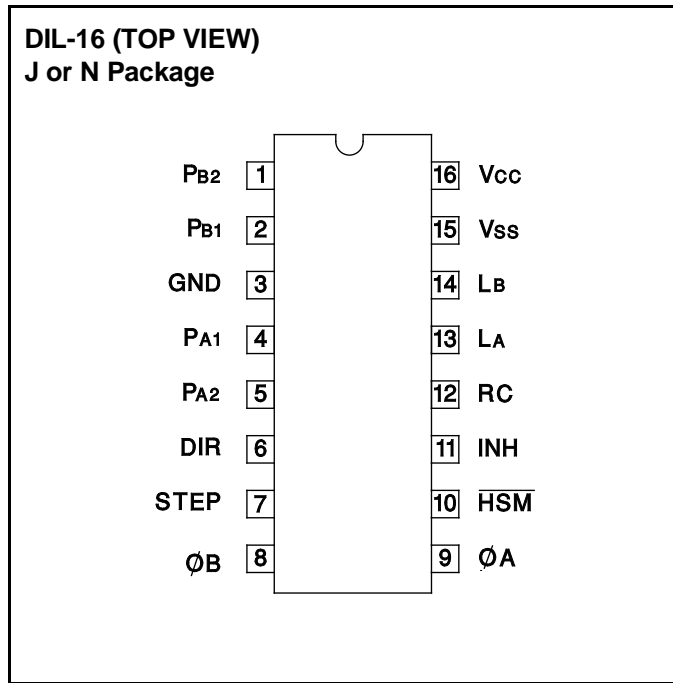

ELECTRICAL CHARACTERISTICS: Unless otherwise stated, these specifications apply for $T_A = -55^{\circ}\text{C}$ to $+125^{\circ}\text{C}$ for the UC1517 and 0°C to $+70^{\circ}\text{C}$ for the UC3517, $V_{CC}=5\text{V}$, $V_{SS} = 20\text{V}$, $T_A=T_J$. Pin numbers refer to DIL-16 package.

PARAMETER	TEST CONDITIONS	UC1517 / UC3517			UNITS
		MIN	TYP	MAX	
Logic Supply, Vcc	Pin 16	4.75		5.25	V
Second Supply, Vss	Pin 15	10		40	V
Logic Supply Current	$V_{INH} = 0.4\text{V}$		45	60	mA
	$V_{INH} = 4.0\text{V}$		12		mA
Input Low Voltage	Pins 6, 7, 10, 11			0.8	V
Input High Voltage	Pins 6, 7, 10, 11	2.0			V
Input Low Current	Pins 6, 7, 10, 11; $V = 0\text{V}$	-400			μA
Input High Current	Pins 6, 7, 10, 11; $V = 5\text{V}$			20	μA
Phase Output Saturation Voltage	Pins 1, 2, 4, 5; $I = 350\text{mA}$		0.6	0.85	V
Phase Output Leakage Current	Pins 1, 2, 4, 5; $V = 39\text{V}$			500	μA
Follower Saturation Voltage to Vss	Pins 13,14; $I = 350\text{mA}$			-2	V
Follower Leakage Current	Pins 13,14; $V = 0\text{V}$			500	μA
Output Low Voltage, ØA, ØB	Pins 8, 9; $I = 1.6\text{mA}$		0.1	0.4	V
Phase Turn-On Time	Pins 1, 2, 4, 5		2		μs
Phase Turn-Off Time	Pins 1, 2, 4, 5		1.8		μs
Second-Level On Time, TMONO	Pins 13,14; Figure 3 Test Circuit	275	325	375	μs
Logic Input Set-up Time, ts	Pins 6, 10; Figure 4	400			ns
Logic Input Hold Time, th	Pins 6, 10; Figure 4	0			ns
STEP Pulse Width, tp	Pin 7; Figure 4	800			ns
Timing Resistor Value	Pin 12	1k		100k	Ω
Timing Capacitor Value	Pin 12	0.1		500	nF
Power-On Threshold	Pin 16		4.3		V
Power-Off Threshold	Pin 16		3.8		V
Power Hysteresis	Pin 16		0.5		V

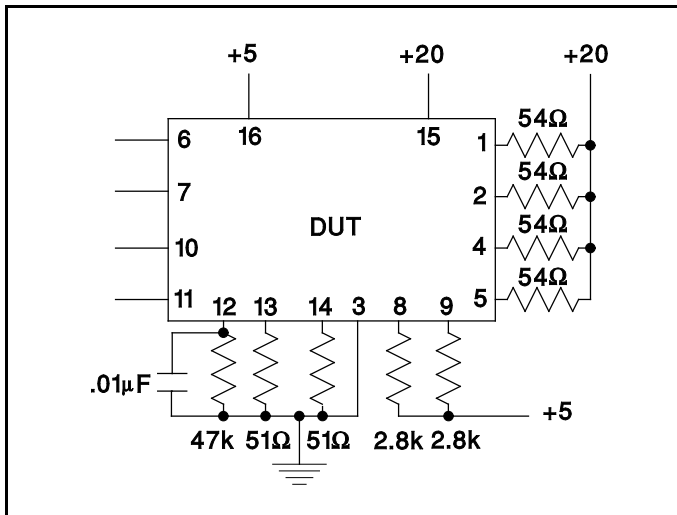

Figure 3. Test Circuit

PIN DESCRIPTION

Vcc: Vcc is the UC3517's logic supply. Connect to a regulated 5VDC, and bypass with a 0.1µF ceramic capacitor to absorb switching transients.

Vmm: Vmm is the primary motor supply. It connects to the UC3517 phase outputs through the motor windings. Limit this supply to less than 40V to prevent breakdown of the phase output transistors. Select the nominal Vmm voltage for the desired continuous winding current.

Vss: Vss is the secondary motor supply. It drives the LA and LB outputs of the UC3517 when a monostable in the UC3517 is active. In the bilevel application, this supply is applied to the motor to charge the winding inductance faster than the primary supply could. Typically, Vss is higher in voltage than Vmm, although Vss must be less than 40V. The Vss supply should have good transient capability.

GROUND: The ground pin is the common reference for all supplies, inputs and outputs.

RC: RC controls the timing functions of the monostables in the UC3517. It is normally connected to a resistor (R_T) and a capacitor (C_T) to ground, as shown in Figure 3. Monostable on time is determined by the formula $T_{ON} \approx 0.69 R_T C_T$. To keep the monostable on indefinitely, pull RC to Vcc through a 50k resistor. The UC3517 contains only one RC pin for two monostables. If step rates comparable to T_{ON} are commanded, incorrect pulsing can result, so consider maximum step rates when selecting R_T and C_T . Keep $T_{ON} \leq T_{STEP MAX}$.

ØA and ØB: These logic outputs indicate half-step position. These outputs are open-collector, low-current drivers, and may directly drive TTL logic. They can also drive CMOS logic if a pull-up resistor is provided. Systems which use the UC3517 as an encoder and use a different driver can use these outputs to disable the external driver,

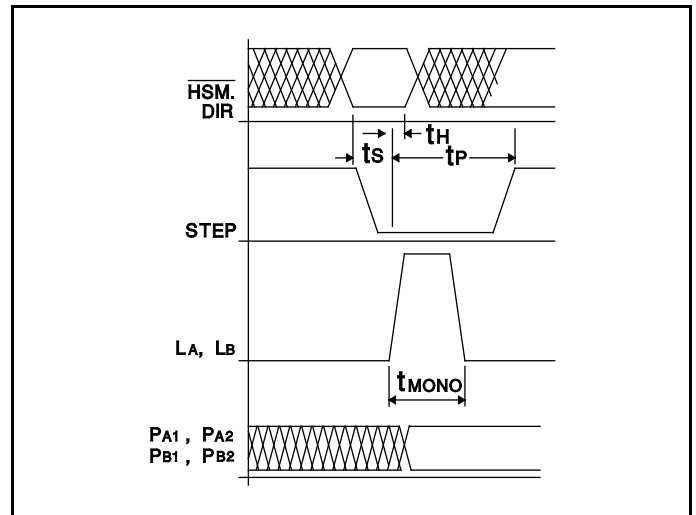

Figure 4. Timing Waveforms

as shown in Figure 8. The sequencing of these outputs is shown in Figure 5.

PA1, PA2, PB1, and PB2: The phase outputs pull to ground sequentially to cause motor stepping, according to the state diagram of Figure 5. The sequence of stepping on these lines, as well as with the LA and LB lines is controlled by STEP input, the DIR input, and the \overline{HSM} input. Caution: If these outputs or any other IC pins are pulled too far below ground either continuously or in a transient, step memory can be lost. It is recommended that these pins be clamped to ground and supply with high-speed diodes when driving inductive loads such as motor windings or solenoids. This clamping is very important because one side of the winding can "kick" in a direction opposite the swing of the other side.

LA and LB: These outputs pull to Vss when their corresponding monostable is active, and will remain high until the monostable time elapses. Before and after, these outputs are high-impedance. For detail timing information, consult Figure 5.

STEP: This logic input clocks the logic in the UC3517 on every falling edge. Like all other UC3517 inputs, this input is TTL/CMOS compatible, and should not be pulled below ground.

DIR: This logic input controls the motor rotation direction by controlling the phase output sequence as shown in Figure 5. This signal must be stable 400ns before a falling edge on STEP, and must remain stable through the edge to insure correct stepping.

HSM: This logic input switches the UC3517 between half-stepping ($\overline{HSM} = \text{low}$) and full-stepping ($\overline{HSM} = \text{high}$) by controlling the phase output sequence as show in Figure 5. This line requires the same set-up time as the DIR input, and has the same hold requirement.

INH: When the inhibit input is high, the phase and θ outputs are inhibited (high impedance). STEP pulses received while inhibited will continue to update logic in the IC, but the states will not be reflected at the outputs until inhibit is pulled low. In stepper motor systems, this can be used to save power or to allow the rotor to move freely for manual repositioning.

OPERATING MODES

The UC3517 is a system component capable of many different operating modes, including:

Unipolar Stepper Driver: In its simplest form, the UC3517 can be connected to a stepper motor as a unipolar driver. LA, LB, RC and Vss are not used, and may be left open. All other system design considerations mentioned above apply, including choice of motor supply VMM, undershoot diodes and timing considerations.

Unipolar Bilevel Stepper Driver: If increased step rates are desired, the application circuit of Figure 6 makes use of the monostables and emitter followers as well as the configuration mentioned above to provide high-voltage pulses to the motor windings when the phase is turned on. For a given dissipation level, this mode offers faster step rates, and very little additional electrical noise.

The choice of monostable components can be estimated based on the timing relationship of motor current and voltage: $V = L di/dt$. Assuming a fixed secondary supply voltage (Vss), a fixed winding inductance (LM), a desired winding peak current (Iw), and no back EMF from the motor, we can estimate that $R_{TCT} = 1.449 IwLM/Vss$. In practice, these calculations should be confirmed and adjusted to accommodate for effects not modeled.

Voltage-Doubled Mode: The UC3517 can also be used to generate higher voltages than available with the system power supplies using capacitors and diodes. Figure 9 shows how this might be done, and gives some estimates for the component values.

Higher Current Operation: For systems requiring more than 350mA of drive per phase, the UC3717A can be

used in conjunction with discrete power transistors or power driver ICs, like the L298. These can be connected as current gain devices that turn on when the phase outputs turn on.

Bipolar Motor Drive: Bipolar motors can be controlled by the UC3517 with the addition of bipolar integrated drivers such as the UC3717A (Figure 8) and the L298, or discrete devices. Care should be taken with discrete devices to avoid potential cross-conduction problems.

LOGIC FLOW GRAPH

The UC3517 contains a bidirectional counter which is decoded to generate the correct phase and θ outputs. This counter is incremented on every falling edge of the STEP input. Figure 5 shows a graph representing the counter sequence, inputs that determine the next state (DIR and HSM), and the outputs at each state. Each circle represents a unique logic state, and the four inside circles represent the half-step states.

The four bits inside the circles represent the phase outputs in each state (PA1, PA2, PB1, and PB2). For example, the circle labeled 1010 is immediately entered when the device is powered up, and represents PA1 off ("1" or high), PA2 on ("0" or low), PB1 off ("1" or high) and PB2 on ("0" or low). The θ_A and θ_B outputs are both low (unidentified).

The arrows in the graph show the state changes. For example, if the IC is in state 0110, DIR is high, HSM is high, and STEP falls, the next state will be 0101, and a pulse will be generated on the LB line by the monostable.

Inhibit will not effect the logic state, but it will cause all phase outputs and both θ outputs to go high (off). A falling edge on STEP will still cause a state change, but inhibit will have to toggle low for the state to be apparent.

A falling edge on STEP with \overline{HSM} high will cause the counter to advance to the next full step state regardless of whether or not it was in a full step state previously.

No LA or LB pulses are generated entering half-states.

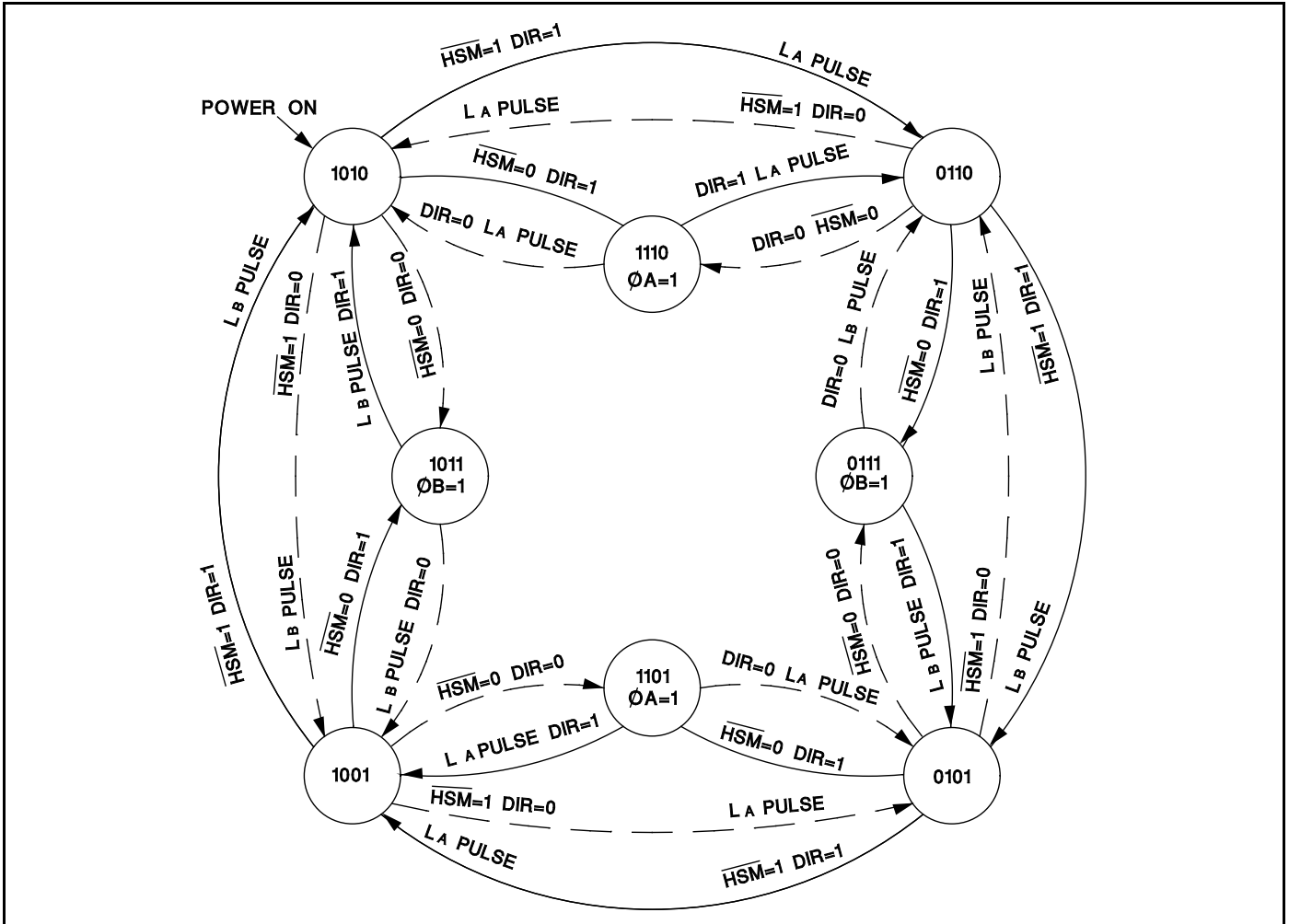
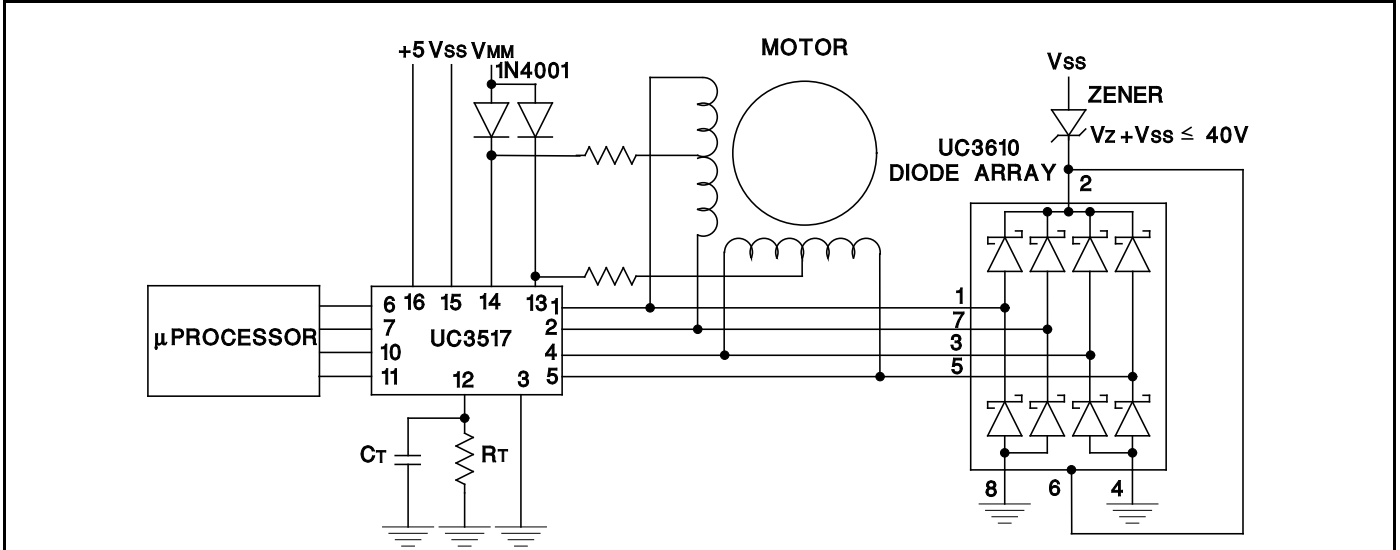
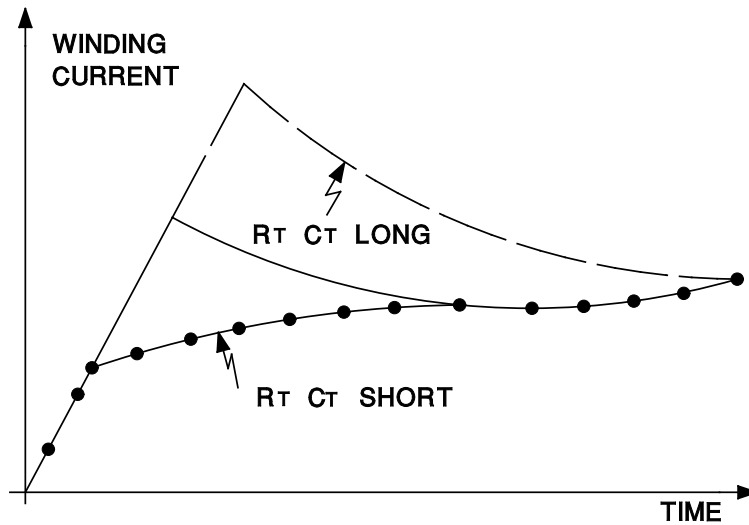

Figure 5. Logic Flow Graph



For applications requiring very fast step rates, a zener diode permits windings to discharge at higher voltages, and higher rates. Driver transistor breakdown must be considered when selecting V_{SS} and zener voltage to insure that the outputs will not overshoot past 40V. If the zener diodes are not used and UC3610 pin 2 is connected directly to V_{SS} then higher V_{SS} can be used.

Figure 6. Bilevel Motor Driver



Experimental selection of RT and CT allow the designer to select a small amount of winding current overshoot, as shown above. Although the overshoot may exceed the continuous rated current of the winding and the drive transistors, the dura-

tion can be well controlled. Average power dissipation for the driver and motor must be considered when designing systems with intentional overshoot, and must stay within conservative limits for short duty cycles.

Figure 7. Effects of Different RT & CT on Bilevel Systems

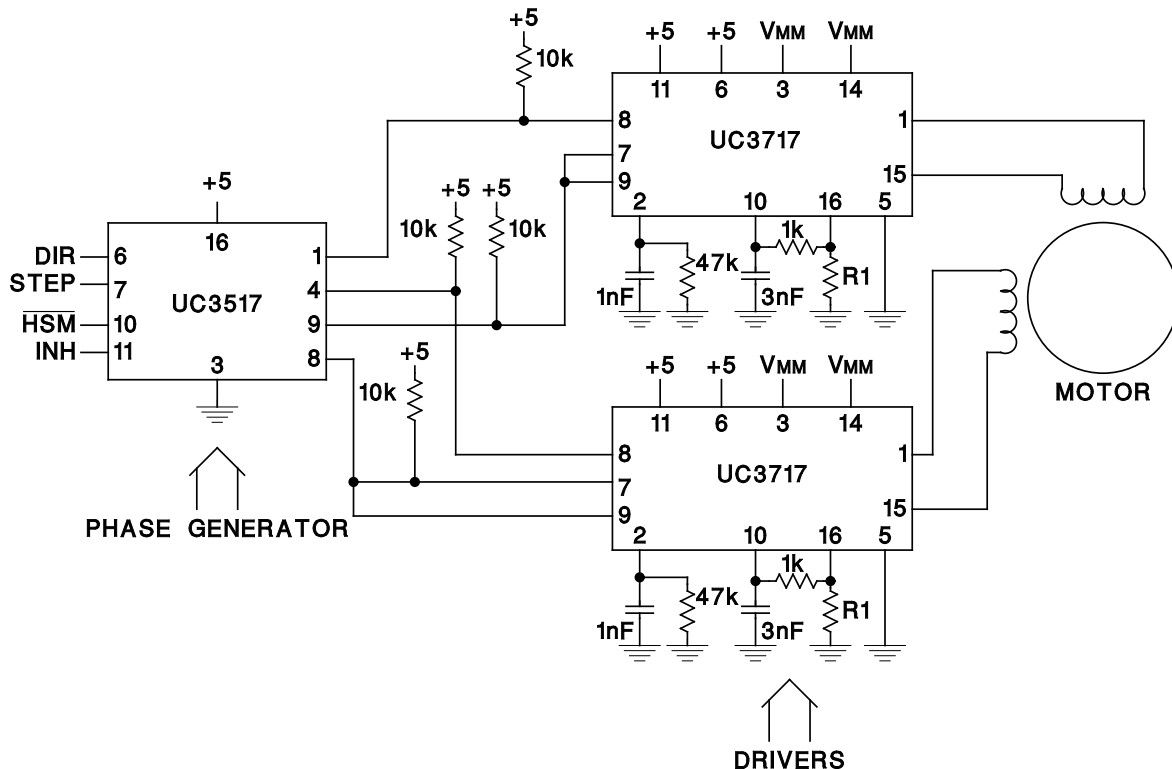

In this application, the $\emptyset A$ and $\emptyset B$ outputs of the UC3517 are connected to the current program inputs of the UC3717. This allows the UC3517 inhibit signal to inhibit the UC3717, and

also allows half-step operation of the UC3717. Peak motor winding current will be limited to approximately $.42V/R1$ by chopping.

Figure 8. Interface to UC3717 Bipolar Driver

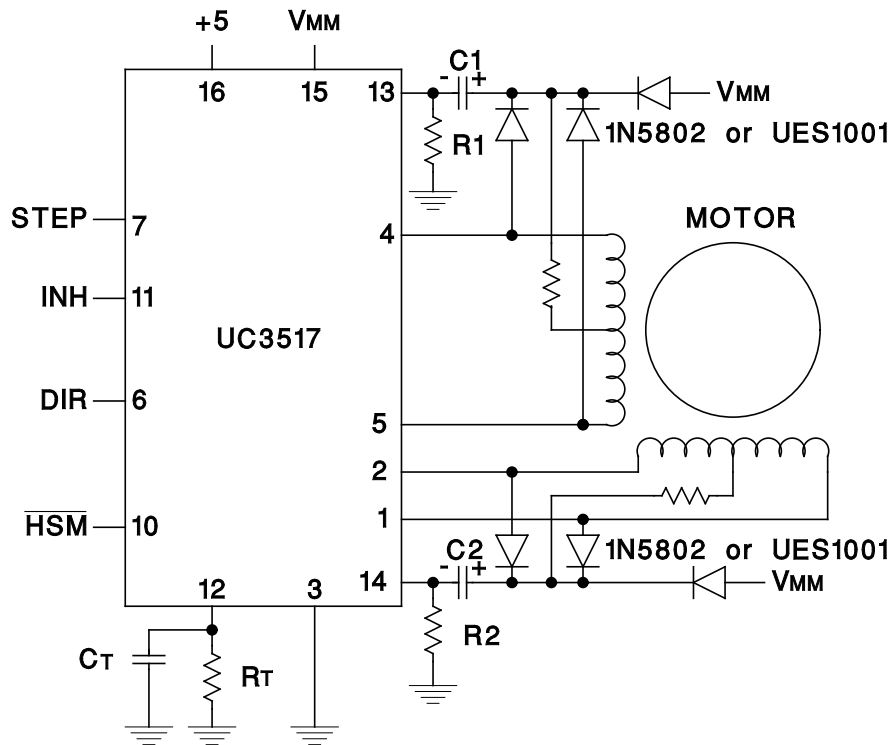

Although component values can be best optimized experimentally, good starting values speed development. For this design, start with:

where:

$$R_T C_T = 3 L_W / R_W$$

$$C_1 = C_2 = L_W I_R / R_W$$

$$R_1 = R_2 = 2.9 T_{MIN} / C_1$$

L_W is winding inductance,
 R_W is winding resistance,
 I_R is rated winding current, and
 T_{MIN} is minimum step period expected.

Figure 9. Using the UC3517 as a Voltage Doubler

IMPORTANT NOTICE

Texas Instruments and its subsidiaries (TI) reserve the right to make changes to their products or to discontinue any product or service without notice, and advise customers to obtain the latest version of relevant information to verify, before placing orders, that information being relied on is current and complete. All products are sold subject to the terms and conditions of sale supplied at the time of order acknowledgement, including those pertaining to warranty, patent infringement, and limitation of liability.

TI warrants performance of its semiconductor products to the specifications applicable at the time of sale in accordance with TI's standard warranty. Testing and other quality control techniques are utilized to the extent TI deems necessary to support this warranty. Specific testing of all parameters of each device is not necessarily performed, except those mandated by government requirements.

CERTAIN APPLICATIONS USING SEMICONDUCTOR PRODUCTS MAY INVOLVE POTENTIAL RISKS OF DEATH, PERSONAL INJURY, OR SEVERE PROPERTY OR ENVIRONMENTAL DAMAGE ("CRITICAL APPLICATIONS"). TI SEMICONDUCTOR PRODUCTS ARE NOT DESIGNED, AUTHORIZED, OR WARRANTED TO BE SUITABLE FOR USE IN LIFE-SUPPORT DEVICES OR SYSTEMS OR OTHER CRITICAL APPLICATIONS. INCLUSION OF TI PRODUCTS IN SUCH APPLICATIONS IS UNDERSTOOD TO BE FULLY AT THE CUSTOMER'S RISK.

In order to minimize risks associated with the customer's applications, adequate design and operating safeguards must be provided by the customer to minimize inherent or procedural hazards.

TI assumes no liability for applications assistance or customer product design. TI does not warrant or represent that any license, either express or implied, is granted under any patent right, copyright, mask work right, or other intellectual property right of TI covering or relating to any combination, machine, or process in which such semiconductor products or services might be or are used. TI's publication of information regarding any third party's products or services does not constitute TI's approval, warranty or endorsement thereof.