

- Pin Compatible With PCA82C250 and DeviceNet, SDS
- ISO11898 Compatible
- High Speed, up to 1 Mbps
- Differential Transmit to the Bus and Receive From the Bus to the CAN Controller
- At Least 110 Nodes Can Be Connected
- 100-V Transient Protection on the Transmit Output
- 24-V Supply Cross Wire Protection on CANH and CANL
- No Bus Loading When Powered Down
- Operates Between -40°C to 85°C
- Unitrode DeviceNet ID#107

D AND N PACKAGE
(TOP VIEW)

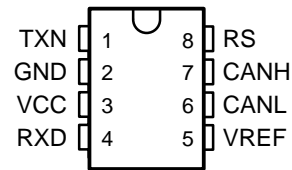

NOTE:
THIS PRODUCT IS NOT RECOMMENDED
FOR NEW DESIGNS. IT WILL SOON BE
REPLACED BY PART NUMBER
SN65HVD251.

description

The UC5350 control area network (CAN) transceiver is designed for industrial applications employing the CAN serial communications physical layer per ISO 11898 standard. The device is a high-speed transceiver designed for use up to 1 Mbps. Especially designed for hostile environments, this device features cross wire, loss of ground, overvoltage, and overtemperature protections as well as a wide common-mode range.

The transceiver interfaces the single-ended CAN controller with the differential CAN bus found in industrial and automotive applications. It operates over the -7-V to 12-V common-mode range of the bus and will withstand common-mode transients of -25 V to 18 V as well as Schaffner tests. Performance features include high differential-input impedance, a symmetrical-differential-signal driver, and very-low propagation delay that improves bus bandwidth and length by reducing reflection and distortion.

The transceiver operates over a wide temperature range, -40°C to 85°C and is available in 8-pin SOIC and dual-in-line packages.

block diagram

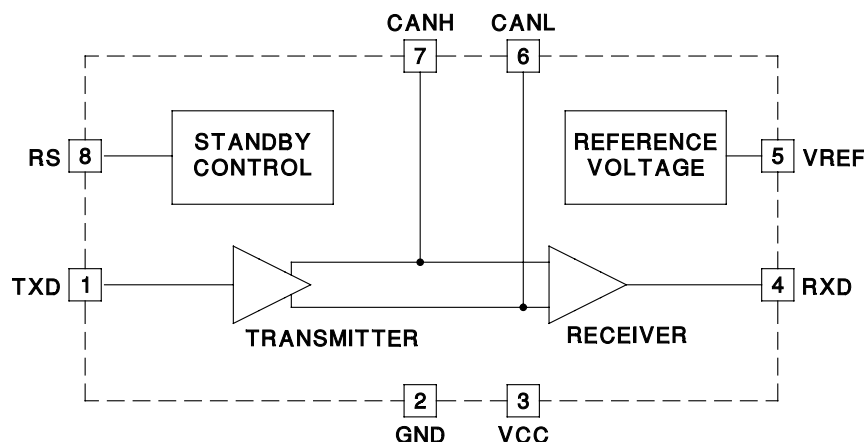

UDG-96202



Please be aware that an important notice concerning availability, standard warranty, and use in critical applications of Texas Instruments semiconductor products and disclaimers thereto appears at the end of this data sheet.

PRODUCTION DATA information is current as of publication date. Products conform to specifications per the terms of Texas Instruments standard warranty. Production processing does not necessarily include testing of all parameters.

TEXAS
INSTRUMENTS

POST OFFICE BOX 655303 • DALLAS, TEXAS 75265

Copyright © 2001, Texas Instruments Incorporated

UC5350 CAN TRANSCEIVER

SLUS258C – MARCH 2000 – REVISED DECEMBER 2001

functional table (VCC = 4.5 V to 5.5 V)

Inputs		System Mode	Output Mode	Outputs	
TXD	RS			V _{CANH} – V _{CANL}	RXD
0	0	High speed	Dominant	1.5 V to 3 V	0
1	0	High speed	Recessive	–120 mV to 12 mV	1
High Z	0	High speed	Recessive	–120 mV to 12 mV	1
X	1	Standby	—	High Z	0 at Bus = Dominant
					1 at Bus = Recessive

absolute maximum ratings over operating free-air temperature (unless otherwise noted)†‡

Supply voltage	–0.3 V to 9 V
TXD, RXD, VREF, RS	–0.3 V to VCC + 0.3 V
CANL, CANH, (0 V < VCC < 5.5 V)	–8 V to 36 V
CANL, CANH, (non-destructive, non-operative)	–8 V to 32 V
CANL, CANH, (transient, Schaffner test) See Figure 1	–150 V to 100 V
Operating temperature	–40°C to 85°C
Storage temperature, T _{stg}	–65°C to 150°C
Junction temperature, T _J	–55°C to 150°C
Lead temperature (soldering, 10 sec.)	300°C
Crosswire protection maximum VBUS	30 V
Bus differential voltage★	30 V
Cross wire protection T _A	–40°C to 125°C

† Stresses beyond those listed under “absolute maximum ratings” may cause permanent damage to the device. These are stress ratings only, and functional operation of the device at these or any other conditions beyond those indicated under “recommended operating conditions” is not implied. Exposure to absolute-maximum-rated conditions for extended periods may affect device reliability.

‡ Currents are positive into, negative out of the specified terminal. Consult Packaging Section of the *Interface Products Data Book* (TI Literature Number SLUU002) for thermal limitations and considerations of packages.

★ Refers to Figures 9, 10, 11, 12 and 13.

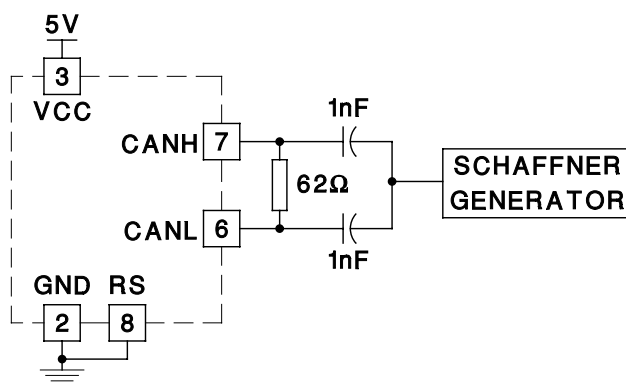

NOTE: See Figure 7 for pulse timing.

UDG-96203-1

Figure 1. Schaffner Test

electrical characteristics (total device disconnected from the bus line), VCC = 4.5 V to 5.5 V, 60 Ω in parallel with 100-pF load between CANH and CANL, T_A = -40°C to 85°C, T_A = T_J, (unless otherwise stated)

PARAMETER	TEST CONDITIONS	MIN	TYP	MAX	UNITS
Supply voltage		4.5		5.5	V
Supply current	Dominant, TXD = 1 V			70	mA
	Recessive, TXD = 4 V		9	14	mA
	Standby, RS = 4 V		1.2	2.0	mA
RS input current		-10		5	μ A
RS voltage input = logic 1	Standby	0.75VCC			V
RS voltage input = logic 0	High speed			0.3VCC	V
Transmitter voltage input = logic 1	Transmitter output recessive	0.7VCC			V
Transmitter voltage input = logic 0	Transmitter output dominant			0.3VCC	V
Transmitter current input at logic 1	TXD = 4 V			30	μ A
Transmitter current input at logic 0	TXD = 1 V	-30		30	μ A
Receiver voltage output = logic 1	RXD = -100 mA, TXD = 4 V	VCC -1.25			V
Receiver voltage output = logic 0	RXD = 1 mA, TXD = 1 V		0.75	1.2	V
	RXD = 10 mA, TXD = 1 V		1.2	1.7	V
CANH, CANL input resistance	No load, TXD = 4 V	20	40		k Ω
Differential input resistance	No load, TXD = 4 V	40	80		k Ω
CANH, CANL input capacitance	See Note 1			20	pF
Differential input capacitance	See Note 1			10	pF
Reference output voltage	VREF = \pm 50 mA	0.45VCC		0.55VCC	V

NOTE 1: Ensured by design. Not production tested.

UC5350 CAN TRANSCEIVER

SLUS258C – MARCH 2000 – REVISED DECEMBER 2001

electrical characteristics, (dc parameters for recessive state disconnected from the bus line), $60\ \Omega$ in parallel with 100-pF load between CANH and CANL, $T_A = -40^\circ\text{C}$ to 85°C , $T_A = T_J$, (unless otherwise stated)

PARAMETER	TEST CONDITIONS	MIN	TYP	MAX	UNITS
V_{CANH}, V_{CANL}	No load, TXD = 4 V, See Figure 2	2	2.5	3	V
Differential output transmitter ($V_{CANH} - V_{CANL}$)	No load, TXD = 4 V, See Figure 2	-500	0	50	mV
Differential input receiver	Common mode range = -7 V to 12 V, CANH, CANL externally driven, TXD = 4 V, See Figure 3	-1		0.40	V
Differential input resistance	No load	40			$k\Omega$
CANH, CANL input resistance		20			$k\Omega$

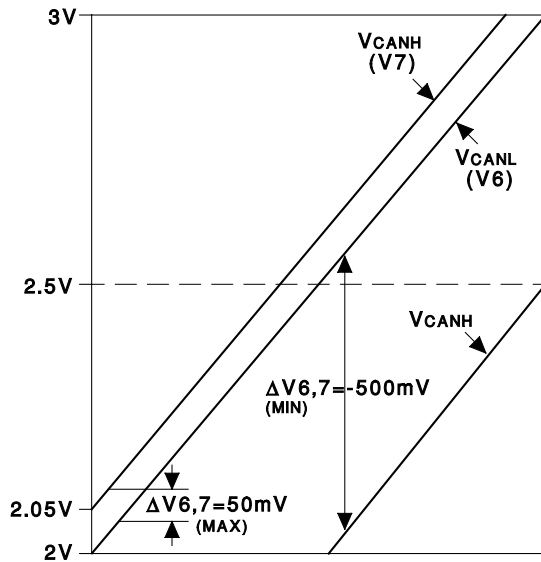

NOTE: Valid output of CANH, CANL during recessive state transmission. TXD = LOGIC 1

UDG-96204

Figure 2. Recessive State Voltage Diagram

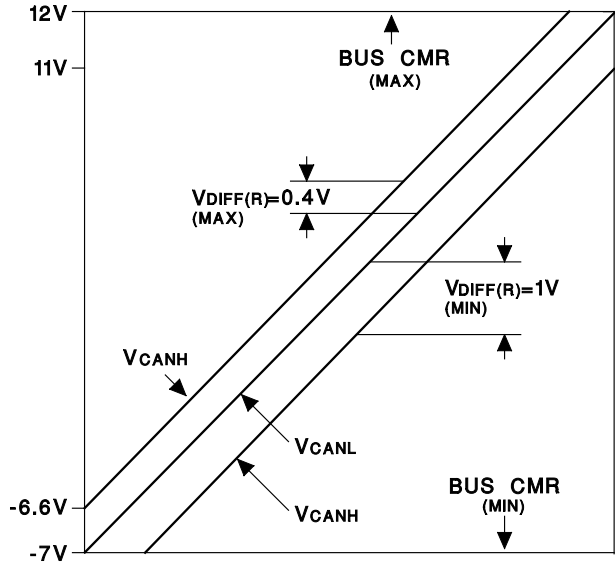

NOTE: Valid voltage range of V_{CANH} for sensing dominant bus state as V_{CANL} varies over bus common range mode. TXD = LOGIC1

UDG-96205

Figure 3. Recessive State Voltage Diagram

electrical characteristics, (dc parameters for dominant state disconnected from the bus line), $60\ \Omega$ in parallel with 100-pF load between CANH and CANL. $V_{CC} = 4.5\text{ V to }5.5\text{ V}$,) (unless otherwise stated)

PARAMETER	TEST CONDITIONS		MIN	TYP	MAX	UNITS
CANH output voltage (V_{CANH})	TXD = 1 V,	See Figure 4	2.75		4.5	V
CANL output voltage (V_{CANL})	TXD = 1 V,	See Figure 4	0.50	1.1	2.25	V
Differential output transmitter ($V_{CANH} - V_{CANL}$)	TXD = 1 V,	See Figure 4	1.5	2	3	V
Differential input receiver ($V_{DIFF}(D)$)	Common mode range = -2 to 7 V, CANH, CANL externally driven,	TXD = 4 V, See Figure 5	0.9		5	V
	Common mode range = -7 to 12 V, CANH, CANL externally driven,	TXD = 4 V, See Figure 5	1.0		5	V

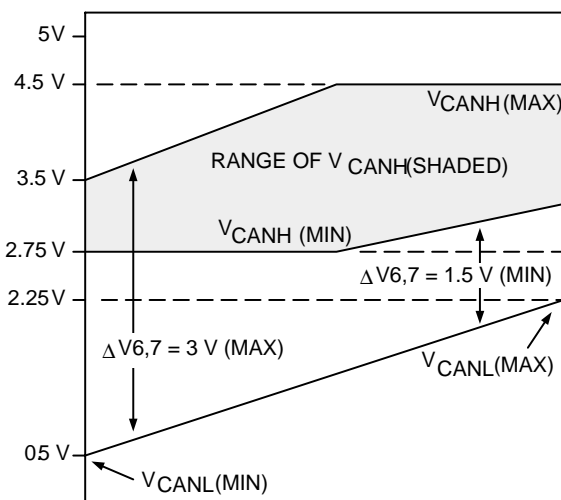

NOTE: Valid voltage range of V_{CANH} for sensing dominant bus state as V_{CANL} varies. TXD = LOGIC 0

UDG-97160

Figure 4. Dominant State Voltage Diagram

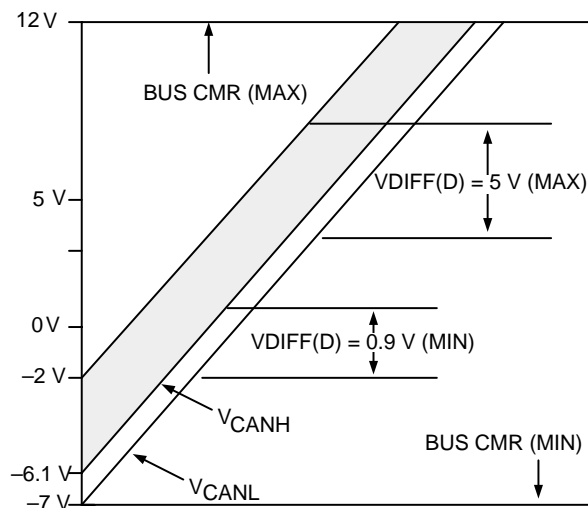

NOTE: Valid voltage range of V_{CANH} for sensing dominant bus state as V_{CANL} varies over bus common mode range. TXD = LOGIC 0

UDG-97160

Figure 5. Dominant State Voltage Diagram

UC5350 CAN TRANSCEIVER

SLUS258C – MARCH 2000 – REVISED DECEMBER 2001

transmitter characteristics, (disconnected from the bus line), 60 Ω in parallel with 100-pF load between CANH and CANL, (unless otherwise stated)

PARAMETER	TEST CONDITIONS	MIN	TYP	MAX	UNITS
Differential output transmitter ($V_{CANH} - V_{CANL}$)	Dominant mode	1.5	2	3	V
	Recessive mode	-500		50	mV
Delay from TXD to bus active T_{ON} (TXD)	See Figure 6		50	100	ns
Delay from TXD to bus inactive T_{OFF} (TXD)	60 Ω across CANH and CANL, See Figure 6		20	110	ns

receiver characteristics, (disconnected from the bus line), 60 Ω in parallel with 100-pF load between CANH and CANL, (unless otherwise stated)

PARAMETER	TEST CONDITIONS	MIN	TYP	MAX	UNITS
Differential input receiver ($V_{CANH} - V_{CANL}$)	Dominant mode, TXD = 4 V	0.9			V
	Recessive mode, TXD = 4 V			0.4	V
Differential input hysteresis	TXD = 4 V	75	150		mV
Delay from bus to RXD (T_{ON})	Inactive to active bus, See Figure 6		60	100	ns
Delay from bus to RXD (T_{OFF})	Active to inactive bus, 60 Ω across CANH and CANL, See Figure 6		80	115	ns

transceiver characteristics

PARAMETER	TEST CONDITIONS	MIN	TYP	MAX	UNITS
Loop time	$T_{ON} (TXD) + T_{ON} (RXD)$ inactive to active bus		110	200	ns
	$T_{OFF} (TXD) + T_{OFF} (RXD)$ active to inactive bus		100	225	ns

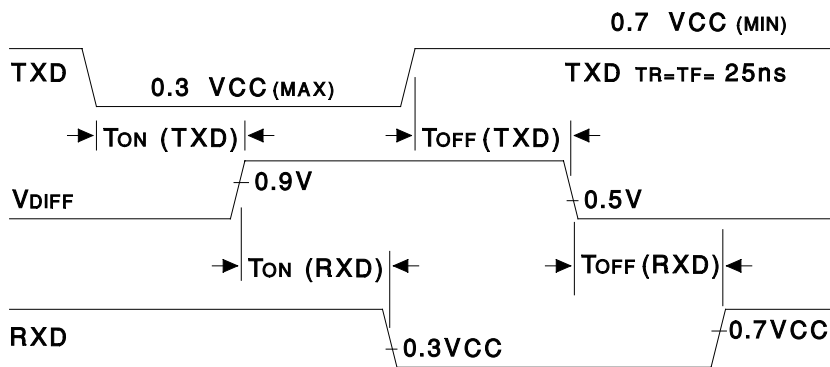

UDG-96208

Figure 6. Transceiver ac Response

APPLICATION INFORMATION

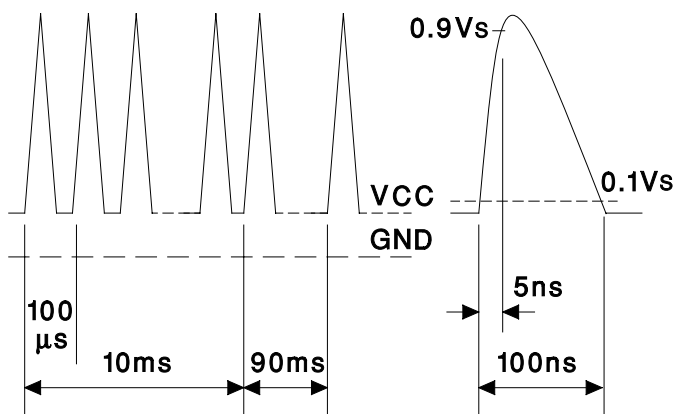

UDG-96209

Figure 7. Timing Diagram for Schaffner Tests

Table 1. Magnitude Specifications for V_S

ISO	DIN 40839-1	Schaffner
DP7637/1	(Draft)	NSG500C/506C
Up to 150 V	Up to 150 V	40 V to 200 V

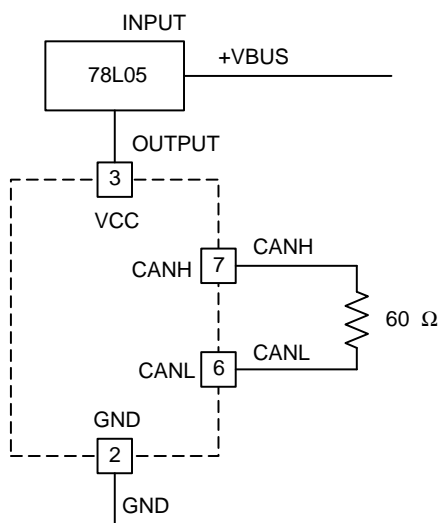

Figure 8. Normal Connection

UDG-97175

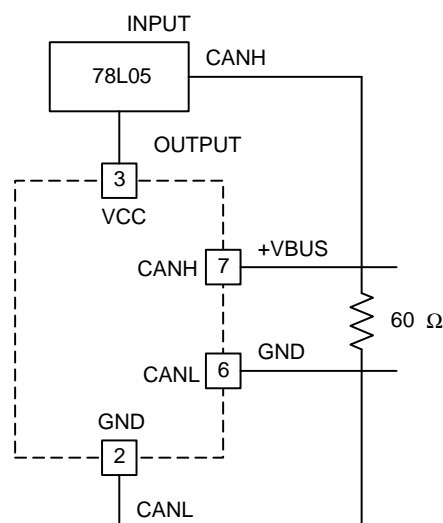

Figure 9. Crosswire No. 1

UDG-97176

APPLICATION INFORMATION

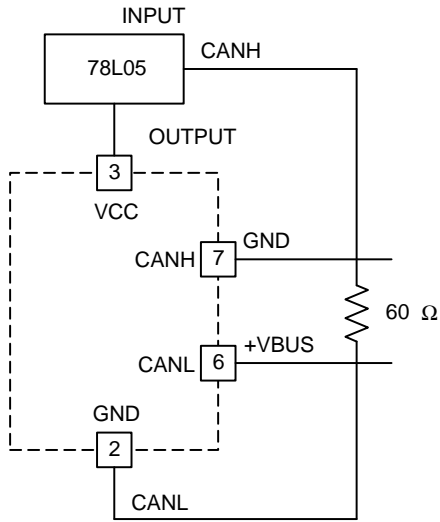

Figure 10. Crosswire No. 2

UDG-97177

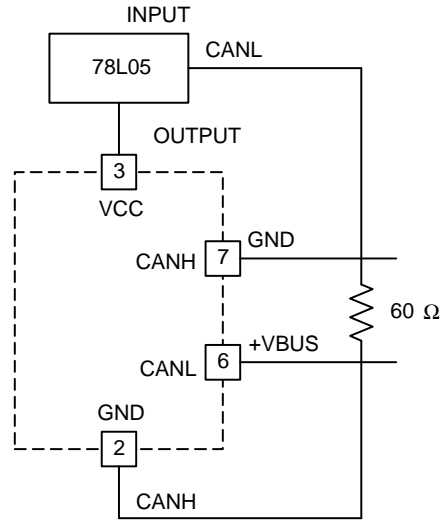

Figure 11. Crosswire No. 3

UDG-97178

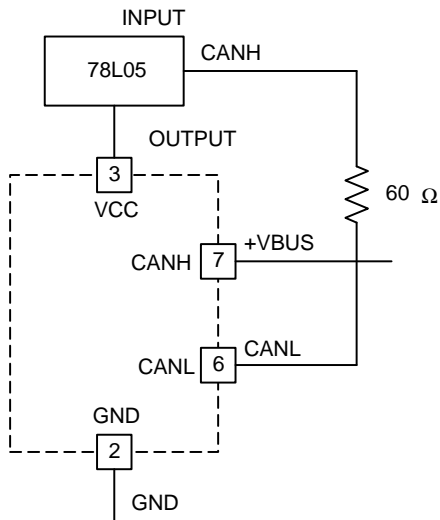

Figure 12. Crosswire No. 4

UDG-97179

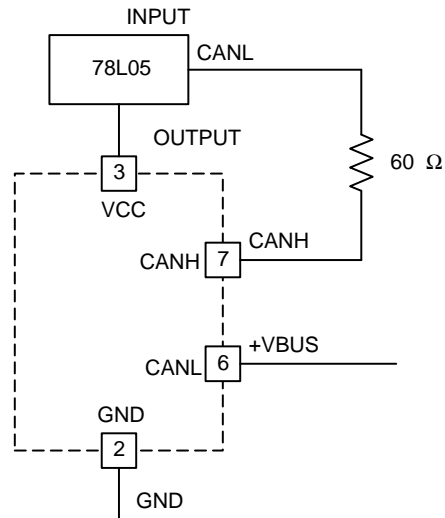

Figure 13. Crosswire No. 5

UDG-97180

IMPORTANT NOTICE

Texas Instruments Incorporated and its subsidiaries (TI) reserve the right to make corrections, modifications, enhancements, improvements, and other changes to its products and services at any time and to discontinue any product or service without notice. Customers should obtain the latest relevant information before placing orders and should verify that such information is current and complete. All products are sold subject to TI's terms and conditions of sale supplied at the time of order acknowledgment.

TI warrants performance of its hardware products to the specifications applicable at the time of sale in accordance with TI's standard warranty. Testing and other quality control techniques are used to the extent TI deems necessary to support this warranty. Except where mandated by government requirements, testing of all parameters of each product is not necessarily performed.

TI assumes no liability for applications assistance or customer product design. Customers are responsible for their products and applications using TI components. To minimize the risks associated with customer products and applications, customers should provide adequate design and operating safeguards.

TI does not warrant or represent that any license, either express or implied, is granted under any TI patent right, copyright, mask work right, or other TI intellectual property right relating to any combination, machine, or process in which TI products or services are used. Information published by TI regarding third-party products or services does not constitute a license from TI to use such products or services or a warranty or endorsement thereof. Use of such information may require a license from a third party under the patents or other intellectual property of the third party, or a license from TI under the patents or other intellectual property of TI.

Reproduction of information in TI data books or data sheets is permissible only if reproduction is without alteration and is accompanied by all associated warranties, conditions, limitations, and notices. Reproduction of this information with alteration is an unfair and deceptive business practice. TI is not responsible or liable for such altered documentation.

Resale of TI products or services with statements different from or beyond the parameters stated by TI for that product or service voids all express and any implied warranties for the associated TI product or service and is an unfair and deceptive business practice. TI is not responsible or liable for any such statements.

Mailing Address:

Texas Instruments
Post Office Box 655303
Dallas, Texas 75265