



9-Line SCSI Active Terminator

FEATURES

- Complies with SCSI, SCSI-2 and SPI-2 Standards
- 6pF Channel Capacitance during Disconnect
- 100µA Supply Current in Disconnect Mode
- Meets SCSI Hot Plugging
- -400mA Sourcing Current for Termination
- +400mA Sinking Current for Active Negation Drivers
- Logic Command Disconnects all Termination Lines
- Trimmed Termination Current to 3%
- Trimmed Impedance to 3%
- Negative Clamping on all Signal Lines
- Current Limit and Thermal Shutdown Protection

DESCRIPTION

The UC5603 provides 9 lines of active termination for a SCSI (Small Computers Systems Interface) parallel bus. The SCSI standard recommends active termination at both ends of the cable segment.

The UC5603 provides a disconnect feature which, when opened or driven high, will disconnect all terminating resistors, and disables the regulator; greatly reducing standby power. The output channels remain high impedance even without Tempwr applied. A low channel capacitance of 6pF allows units at interim points of the bus to have little to no effect on the signal integrity.

Functionally the UC5603 is similar to its predecessor, the UC5601 - 18 line Active Terminator. Several electrical enhancements were incorporated in the UC5603, such as a sink/source regulator output stage to accommodate all signal lines at +5V, while the regulator remains at its nominal value, reduced channel capacitance to 6pF typical, and as with the UC5601, custom power packages are utilized to allow normal operation at full power conditions (1.2 watts).

Internal circuit trimming is utilized, first to trim the impedance to a 3% tolerance, and then most importantly, to trim the output current to a 3% tolerance, as close to the max SCSI spec as possible, which maximizes noise margin in fast SCSI operation.

Other features include negative clamping on all signal lines to protect external circuitry from latch-up, thermal shutdown and current limit.

This device is offered in low thermal resistance versions of the industry standard 16 pin narrow body SOIC, 16 pin ZIP (zig-zag in line package) and 24 pin TSSOP.

BLOCK DIAGRAM

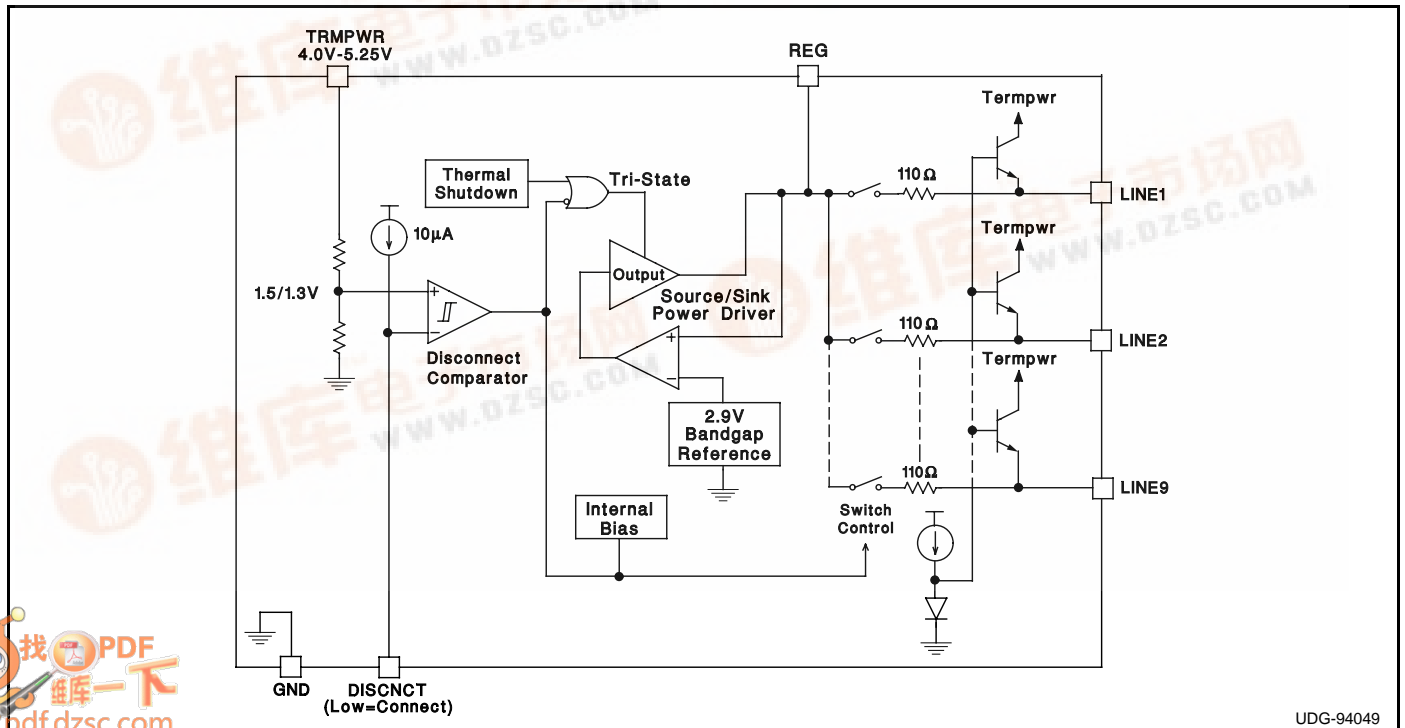

ABSOLUTE MAXIMUM RATINGS

Tempwr Voltage	+7V
Signal Line Voltage	0V to +7V
Regulator Output Current	0.5A
Storage Temperature	-65°C to +150°C
Operating Temperature	-55°C to +150°C
Lead Temperature (Soldering, 10 Sec.)	+300°C

Unless otherwise specified all voltages are with respect to Ground. Currents are positive into, negative out of the specified terminal.

Consult Packaging Section of Unitrode Integrated Circuits databook for thermal limitations and considerations of packages.

RECOMMENDED OPERATING CONDITIONS

Tempwr Voltage	3.8V to 5.25V
Signal Line Voltage	0V to +5V
Disconnect Input Voltage	0V to Tempwr

CONNECTION DIAGRAMS

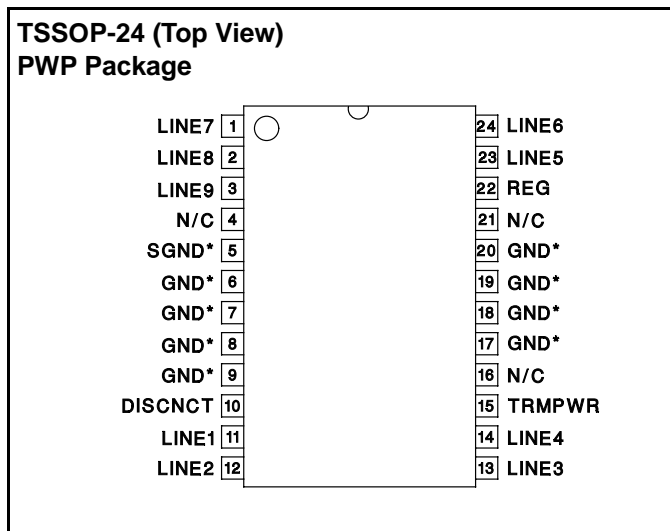
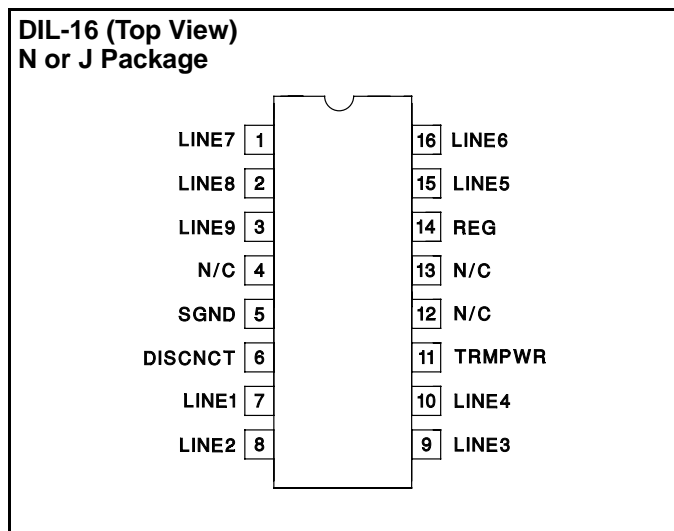

** PWP package pin 5 serves as signal ground; pins 6, 7, 8, 9, 17, 18, 19, and 20 serve as heatsink/ground.*

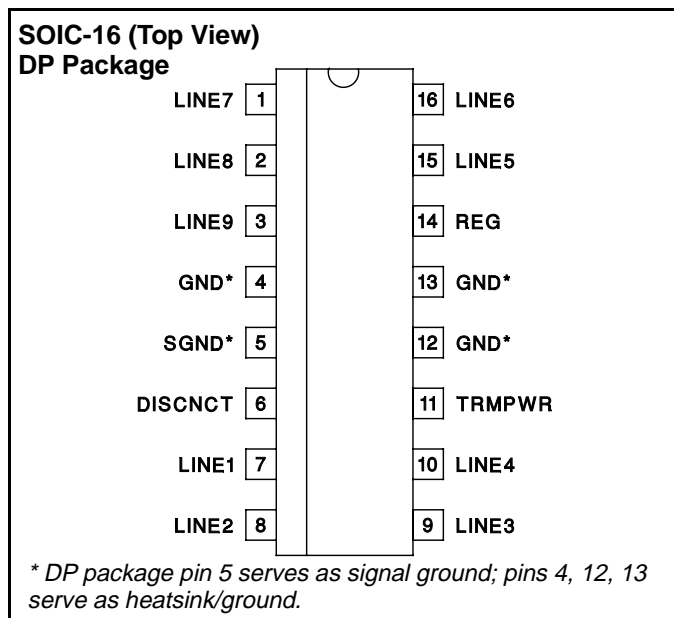

** DP package pin 5 serves as signal ground; pins 4, 12, 13 serve as heatsink/ground.*

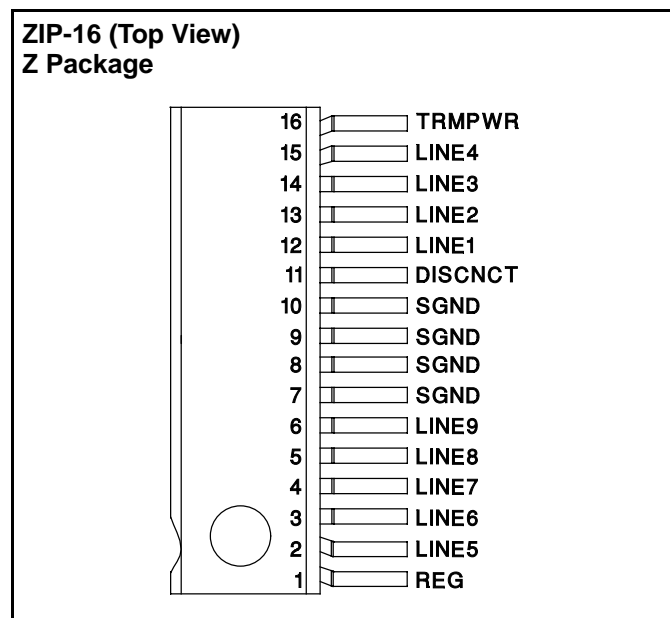

ELECTRICAL CHARACTERISTICS Unless otherwise stated, these specifications apply for $T_A = 0^\circ\text{C}$ to 70°C .
 $\text{TRMPWR} = 4.75\text{V}$ $\text{DISCNCT} = 0\text{V}$. $T_A = T_J$.

PARAMETER	TEST CONDITIONS	MIN	TYP	MAX	UNITS	
Supply Current Section						
Tempwr Supply Current	All termination lines = Open		12	18	mA	
	All termination lines = 0.5V		200	220	mA	
Power Down Mode	DISCNCT = Open		100	150	μA	
Output Section (Terminator Lines)						
Terminator Impedance	$\Delta I_{\text{LINE}} = -5\text{mA}$ to -15mA	107	110	113	Ohms	
Output High Voltage	$V_{\text{TRMPWR}} = 4\text{V}$ (Note 1)	2.7	2.9		V	
Max Output Current	$V_{\text{LINE}} = 0.5\text{V}$	$T_J = 25^\circ\text{C}$	-21.1	-21.9	-22.4	mA
		$0^\circ\text{C} < T_J < 70^\circ\text{C}$	-20.5	-21.9	-22.4	mA
Max Output Current	$V_{\text{LINE}} = 0.5\text{V}$, $\text{TRMPWR} = 4\text{V}$ (Note 1)	$T_J = 25^\circ\text{C}$	-20.3	-21.9	-22.4	mA
		$0^\circ\text{C} < T_J < 70^\circ\text{C}$	-19.8	-21.9	-22.4	mA
	$V_{\text{LINE}} = 0.2\text{V}$, $\text{TRMPWR} = 4.0\text{V}$ to 5.25V	$0^\circ\text{C} < T_J < 70^\circ\text{C}$	-22.0	-24.0	-25.4	mA
Output Clamp Level	$I_{\text{LINE}} = -30\text{mA}$	-0.2	-0.05	0.1	V	
Output Leakage	DISCNCT = 4V	TRMPWR = 0V to 5.25V REG = 0V	$V_{\text{LINE}} = 0$ to 4V	10	400	nA
			$V_{\text{LINE}} = 5.25\text{V}$		100	μA
		TRMPWR = 0V to 5.25V, REG = Open $V_{\text{LINE}} = 0\text{V}$ to 5.25V		10	400	nA
Output Capacitance	DISCNCT = Open (Note 2) (DP Package)		6	8	pF	
Regulator Section						
Regulator Output Voltage		2.8	2.9	3	V	
Regulator Output Voltage	All Termination Lines = 5V	2.8	2.9	3	V	
Line Regulation	$\text{TRMPWR} = 4\text{V}$ to 6V		10	20	mV	
Load Regulation	$I_{\text{REG}} = +100\text{mA}$ to -100mA		20	50	mV	
Drop Out Voltage	All Termination Lines = 0.5V		0.7	1	V	
Short Circuit Current	$V_{\text{REG}} = 0\text{V}$	-200	-400	-600	mA	
Sinking Current Capability	$V_{\text{REG}} = 3.5\text{V}$	200	400	600	mA	
Thermal Shutdown			170		$^\circ\text{C}$	
Thermal Shutdown Hysteresis			10		$^\circ\text{C}$	
Disconnect Section						
Disconnect Threshold		1.3	1.5	1.7	V	
Threshold Hysteresis		100	160	250	mV	

Note 1: Measuring each termination line while other 8 are low (0.5V).

Note 2: Guaranteed by design. Not 100% tested in production.

APPLICATION INFORMATION

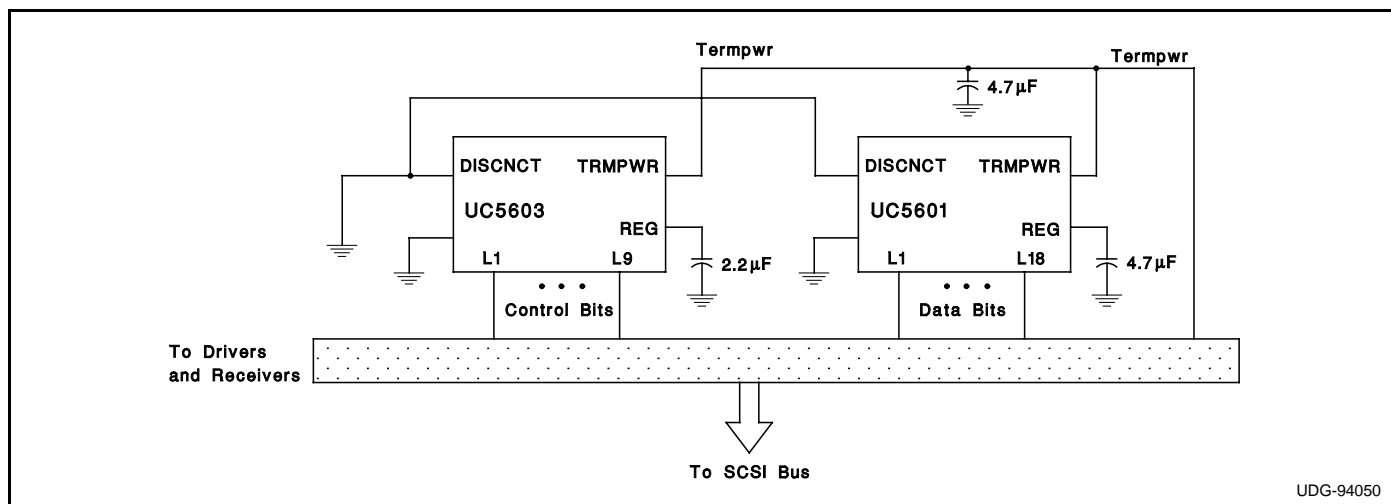

Figure 1: Typical Wide SCSI Bus Configurations Utilizing 1 UC5601 and 1 UC5603 Device

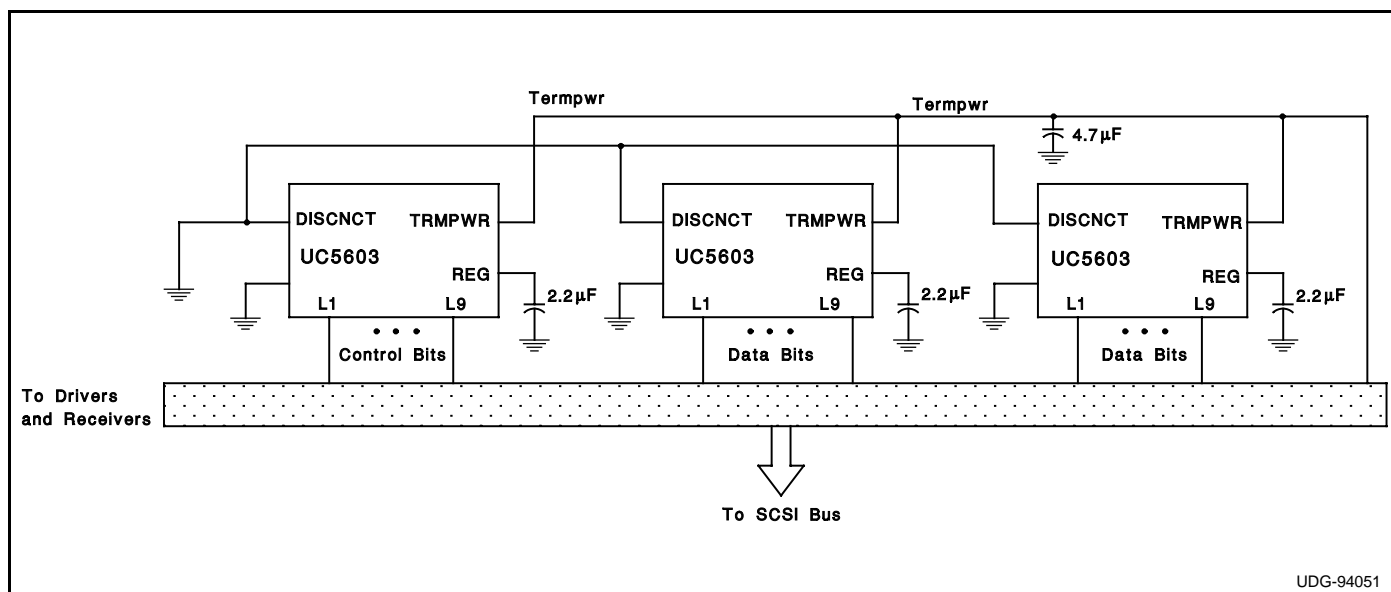

Figure 2: Typical Wide SCSI Bus Configurations Utilizing 3 UC5603 Devices.

IMPORTANT NOTICE

Texas Instruments and its subsidiaries (TI) reserve the right to make changes to their products or to discontinue any product or service without notice, and advise customers to obtain the latest version of relevant information to verify, before placing orders, that information being relied on is current and complete. All products are sold subject to the terms and conditions of sale supplied at the time of order acknowledgement, including those pertaining to warranty, patent infringement, and limitation of liability.

TI warrants performance of its semiconductor products to the specifications applicable at the time of sale in accordance with TI's standard warranty. Testing and other quality control techniques are utilized to the extent TI deems necessary to support this warranty. Specific testing of all parameters of each device is not necessarily performed, except those mandated by government requirements.

CERTAIN APPLICATIONS USING SEMICONDUCTOR PRODUCTS MAY INVOLVE POTENTIAL RISKS OF DEATH, PERSONAL INJURY, OR SEVERE PROPERTY OR ENVIRONMENTAL DAMAGE ("CRITICAL APPLICATIONS"). TI SEMICONDUCTOR PRODUCTS ARE NOT DESIGNED, AUTHORIZED, OR WARRANTED TO BE SUITABLE FOR USE IN LIFE-SUPPORT DEVICES OR SYSTEMS OR OTHER CRITICAL APPLICATIONS. INCLUSION OF TI PRODUCTS IN SUCH APPLICATIONS IS UNDERSTOOD TO BE FULLY AT THE CUSTOMER'S RISK.

In order to minimize risks associated with the customer's applications, adequate design and operating safeguards must be provided by the customer to minimize inherent or procedural hazards.

TI assumes no liability for applications assistance or customer product design. TI does not warrant or represent that any license, either express or implied, is granted under any patent right, copyright, mask work right, or other intellectual property right of TI covering or relating to any combination, machine, or process in which such semiconductor products or services might be or are used. TI's publication of information regarding any third party's products or services does not constitute TI's approval, warranty or endorsement thereof.