



9-Line Low Capacitance SCSI Active Terminator

FEATURES

- Reverse Disconnect
- Complies with SCSI, SCSI-2 and SPI-2 Standards
- 5pF Channel Capacitance during Disconnect
- Hot Plugging Capability
- -400mA Sourcing Current for Termination
- +100mA Sinking Current for Active Negation
- 1V Dropout Voltage Regulator
- 100µA Supply Current in Disconnect Mode
- Trimmed Termination Current to 5%
- Trimmed Impedance to 5%
- Low Thermal Resistance Surface Mount Packages

DESCRIPTION

The UC5605 provides 9 lines of active termination for a SCSI (Small Computer Systems Interface) parallel bus. The SCSI standard recommends active termination at both ends of the cable segment.

The only functional differences between the UC5603 and UC5605 is the absence of the negative clamps on the output lines and the disconnect input must be at a logic-low for the terminating resistors to be disconnected. Parametrically, the UC5605 has a 5% tolerance on impedance and current compared to a 3% tolerance on the UC5603. Custom power packages are utilized to allow normal operation at full power (2 Watts).

The UC5605 provides a disconnect feature which, when driven low, disconnects all terminating resistors, disables the regulator and greatly reduces standby power consumption. The output channels remain high impedance even without Termpwr applied. A low channel capacitance of 5pF allows interim points of the bus to have little to no effect on the signal integrity.

Internal circuit trimming is utilized, first to trim the impedance to a 5% tolerance, and then most importantly, to trim the output current to a 5% tolerance, as close to the maximum SCSI specification as possible. This maximizes the noise margin in fast SCSI operation. Other features include thermal shutdown and current limit.

This device is offered in low thermal resistance versions of the industry standard 16 pin narrow body SOIC, 16 pin ZIP (zig-zag in line package) and 24 pin TSSOP.

BLOCK DIAGRAM

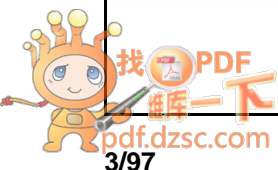
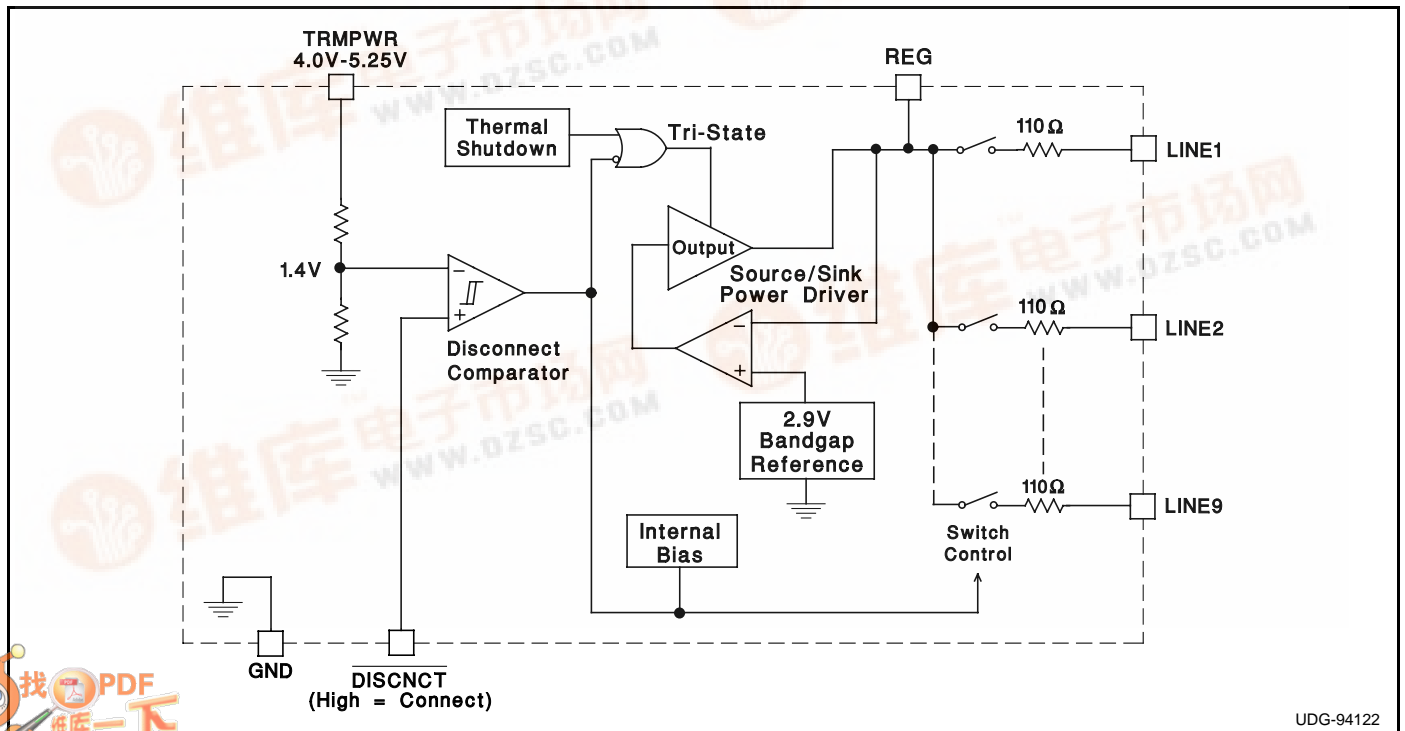

ABSOLUTE MAXIMUM RATINGS

Tempwr Voltage +7V
 Signal Line Voltage 0V to +7V
 Regulator Output Current 0.6A
 Storage Temperature -65°C to +150°C
 Operating Temperature -55°C to +150°C
 Lead Temperature (Soldering, 10 Sec.) +300°C

Unless otherwise specified all voltages are with respect to Ground. Currents are positive into, negative out of the specified terminal.
 Consult Packaging Section of Unitrode Integrated Circuits data-book for thermal limitations and considerations of packages.

RECOMMENDED OPERATING CONDITIONS

Tempwr Voltage 3.8V to 5.25V
 Signal Line Voltage 0V to +5V
 Disconnect Input Voltage 0V to Tempwr

CONNECTION DIAGRAMS

DIL-16 (Top View)
 N or J Package

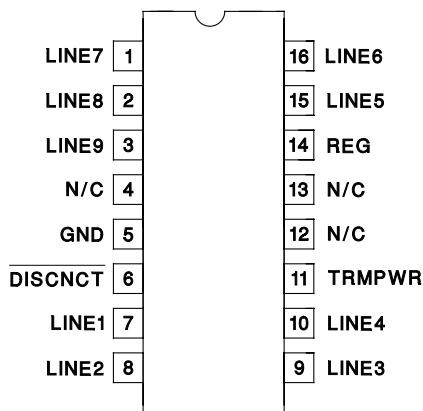

ZIP-16 (Top View)
 Z Package

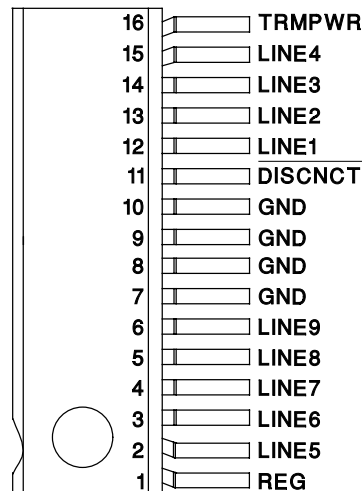

SOIC-16 (Top View)
 DP Package

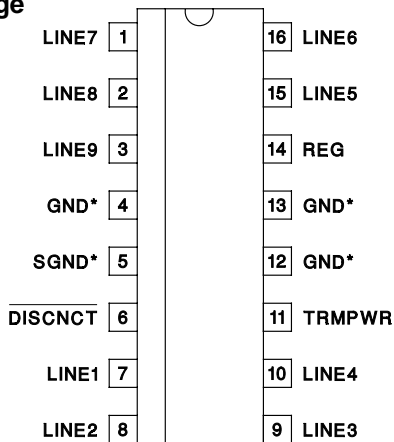

* DP package pin 5 serves as signal ground; pins 4, 12, 13 serve as heatsink/ground.

TSSOP-24 (Top View)
 PWP Package

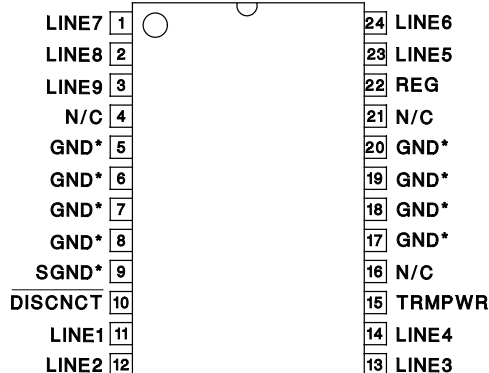

* PWP package pin 9 serves as signal ground; pins 5, 6, 7, 8, 17, 18, 19, and 20 serve as heatsink/ground.

ELECTRICAL CHARACTERISTICS Unless otherwise stated, these specifications apply for $T_A = 0^\circ\text{C}$ to 70°C .
 TRMPWR = 4.75V, DISCNCT = 2.4V, $T_A = T_J$.

PARAMETER	TEST CONDITIONS	MIN	TYP	MAX	UNITS	
Supply Current Section						
Tempwr Supply Current	All termination lines = Open		17	23	mA	
	All termination lines = 0.5V		200	225	mA	
Power Down Mode	DISCNCT = 0V		100	150	μA	
Output Section (Termination Lines)						
Terminator Impedance	$\Delta I_{\text{LINE}} = -5\text{mA}$ to -15mA	104.5	110	115.5	Ohms	
Output High Voltage	TRMPWR = 4V	2.65	2.9	3.1	V	
Max Output Current	V _{LINE} = 0.5V	T _J = 25°C	-20.3	-21.5	-22.4	mA
		0°C < T _J < 70°C	-19.8	-21.5	-22.4	mA
Max Output Current	V _{LINE} = 0.5V, TRMPWR = 4V (Note 1)	T _J = 25°C	-19.5	-21.5	-22.4	mA
		0°C < T _J < 70°C	-19.0	-21.5	-22.4	mA
	V _{LINE} = 0.2V, TRMPWR = 4.0V to 5.25V	0°C < T _J < 70°C	-21.6	-24.0	-25.4	mA
Output Leakage	DISCNCT = 0V TRMPWR = 0V to 5.25V	REG = 0V		10	400	nA
					100	μA
	REG = Open	V _{LINE} = 0V to 5.25V		10	400	nA
Output Capacitance	DISCNCT = 0V (Note 2) (DP Package)		5	6	pF	
Regulator Section						
Regulator Output Voltage		2.7	2.9	3.1	V	
	All Termination Lines = 4V	2.7	2.9	3.1	V	
Line Regulation	TRMPWR = 4V to 6V		10	20	mV	
Drop Out Voltage	All Termination Lines = 0.5V		1.0	1.2	V	
Short Circuit Current	REG = 0V	-200	-400	-600	mA	
Sinking Current Capability	REG = 3.5V	75	100	400	mA	
Thermal Shutdown			170		°C	
Thermal Shutdown Hysteresis			10		°C	
Disconnect Section						
Disconnect Threshold		1.1	1.4	1.7	V	

Note 1: Measuring each termination line while other 8 are low.
 Note 2: Guaranteed by design. Not 100% tested in production.

APPLICATION INFORMATION

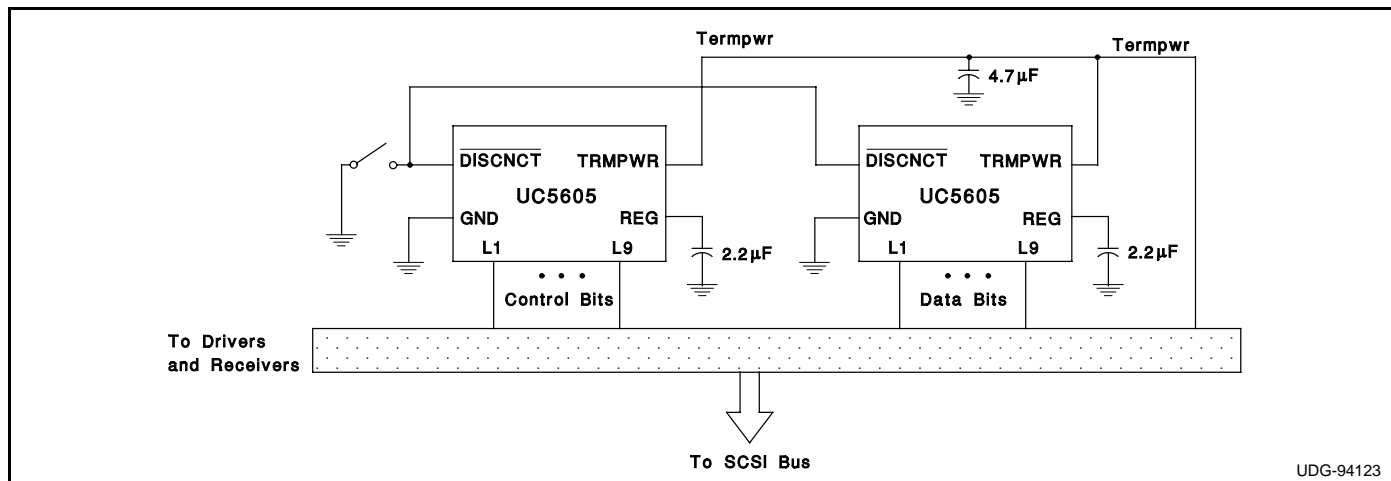

Figure 1: Typical SCSI Bus Configurations Utilizing 2 UC5605 Devices

APPLICATION INFORMATION (cont.)

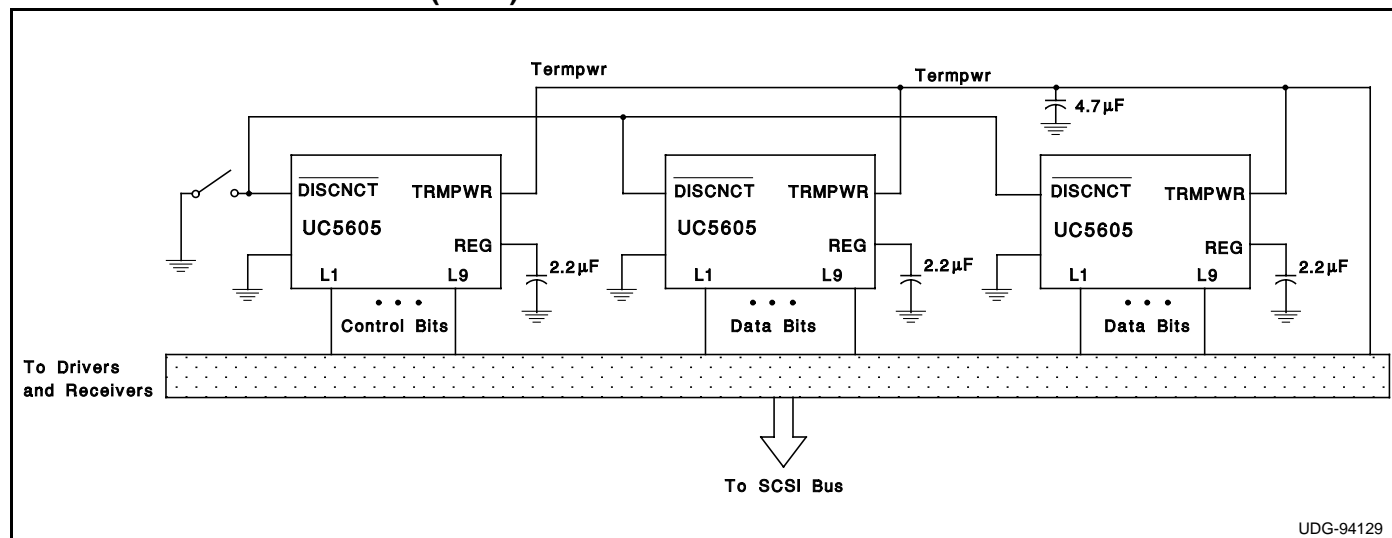

Figure 2: Typical Wide SCSI Bus Configurations Utilizing 3 UC5605 Devices.

UDG-94129

IMPORTANT NOTICE

Texas Instruments and its subsidiaries (TI) reserve the right to make changes to their products or to discontinue any product or service without notice, and advise customers to obtain the latest version of relevant information to verify, before placing orders, that information being relied on is current and complete. All products are sold subject to the terms and conditions of sale supplied at the time of order acknowledgement, including those pertaining to warranty, patent infringement, and limitation of liability.

TI warrants performance of its semiconductor products to the specifications applicable at the time of sale in accordance with TI's standard warranty. Testing and other quality control techniques are utilized to the extent TI deems necessary to support this warranty. Specific testing of all parameters of each device is not necessarily performed, except those mandated by government requirements.

CERTAIN APPLICATIONS USING SEMICONDUCTOR PRODUCTS MAY INVOLVE POTENTIAL RISKS OF DEATH, PERSONAL INJURY, OR SEVERE PROPERTY OR ENVIRONMENTAL DAMAGE ("CRITICAL APPLICATIONS"). TI SEMICONDUCTOR PRODUCTS ARE NOT DESIGNED, AUTHORIZED, OR WARRANTED TO BE SUITABLE FOR USE IN LIFE-SUPPORT DEVICES OR SYSTEMS OR OTHER CRITICAL APPLICATIONS. INCLUSION OF TI PRODUCTS IN SUCH APPLICATIONS IS UNDERSTOOD TO BE FULLY AT THE CUSTOMER'S RISK.

In order to minimize risks associated with the customer's applications, adequate design and operating safeguards must be provided by the customer to minimize inherent or procedural hazards.

TI assumes no liability for applications assistance or customer product design. TI does not warrant or represent that any license, either express or implied, is granted under any patent right, copyright, mask work right, or other intellectual property right of TI covering or relating to any combination, machine, or process in which such semiconductor products or services might be or are used. TI's publication of information regarding any third party's products or services does not constitute TI's approval, warranty or endorsement thereof.