

- **SCSI SPI-2, SPI-3, SPI-4, Ultra160, Ultra320 Compliance**
- **Smallest Footprint**
- **Lowest Channel Capacitance, 2 pF**
- **Less than 0.5-pF Capacitance Differential Between Pairs**
- **2.7 V to 5.25 V Operation**
- **Differential Failsafe Bias**
- **64-Pin Low Profile QFP**

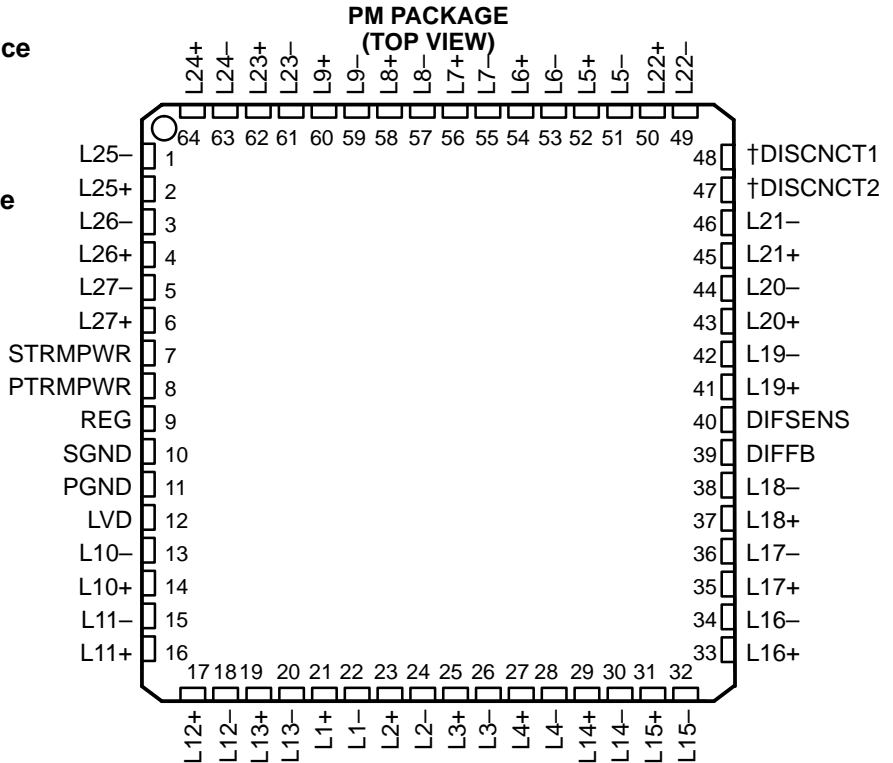

description

†For the UCC5647, Pin 47 is DISCNCT1 and Pin 48 is DISCNCT2.

The UCC5646 is a twenty-seven line active terminator for low-voltage-differential (LVD) SCSI networks. This LVD SCSI-only design allows the user to reach peak bus performance, while reducing system cost. The device is designed as an active Y-terminator to improve the frequency response of the LVD SCSI Bus. Designed with a 2-pF (typical) channel capacitance, the UCC5646 allows for minimal bus loading for a maximum number of peripherals. With the UCC5646, the designer is able to comply with the Ultra2, Ultra3, Ultra160 and Ultra320 specifications. The UCC5646 also provides a much-needed system migration path for the ever improving SCSI system standards.

This device is available in the 64-pin low-profile QFP package for ease of layout use.

Single-ended (SE) and high-voltage differential (HVD) SCSI drivers are not supported.

AVAILABLE OPTIONS

TA	DISCONNECT STATUS	PACKAGED DEVICES†
		LOW PROFILE QFP (PM)
0°C to 70°C	REGULAR	UCC5646PM
	REVERSE	UCC5647PM

† The PM package is available taped and reeled. Add TR suffix to device type (e.g. UCC5646PMTR) to order quantities of 1000 devices per reel.



Please be aware that an important notice concerning availability, standard warranty, and use in critical applications of Texas Instruments semiconductor products and disclaimers thereto appears at the end of this data sheet.

UCC5646, UCC5647
27-LINE 3-V – 5-V LVD TERMINATOR
FOR WIDE ULTRA2, ULTRA3, ULTRA160 AND ULTRA320
 SLUS386B – FEBRUARY 2000 – REVISED APRIL 2001

block diagram

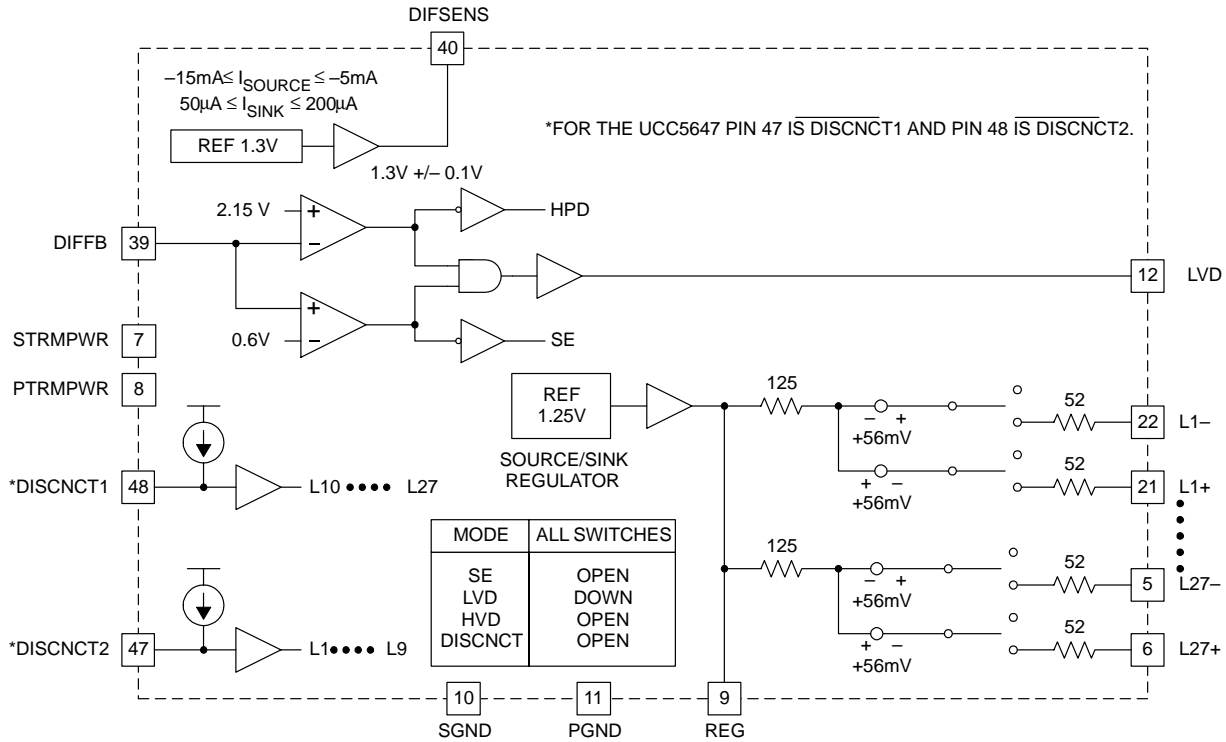

absolute maximum ratings over operating free-air temperature range (unless otherwise noted)†‡

Input voltage V_{IN} (STRMPWR, PTRMPWR)	6 V
Signal line input voltage	0 V to 5 V
Regulator output current	0.75 A
Storage temperature range, T_{stg}	-55°C to 150°C
Operating virtual junction temperature range, T_J	-55°C to 150°C
Lead temperature (soldering, 10 seconds)	300°C

† Stresses beyond those listed under “absolute maximum ratings” may cause permanent damage to the device. These are stress ratings only, and functional operation of the device at these or any other conditions beyond those indicated under “recommended operating conditions” is not implied. Exposure to absolute-maximum-rated conditions for extended periods may affect device reliability.

‡ Unless otherwise indicated, voltages are reference to ground and currents are positive into and negative out of the specified terminals. Consult *Packaging Section* of the Databook for thermal limitations and considerations of packages. All voltages are referenced to GND.

UCC5646, UCC5647
27-LINE 3-V – 5-V LVD TERMINATOR
FOR WIDE ULTRA2, ULTRA3, ULTRA160 AND ULTRA320

SLUS386B – FEBRUARY 2000 – REVISED APRIL 2001

electrical characteristics over recommended operating free-air temperature range, xTRMPWR = 2.7 V to 5.25 V, T_A = 0°C to 70°C, DISCNCT1 = DISCNCT2 = 0 V for UCC5646, DISCNCT1 = DISCNCT2 = open for UCC5647, T_A = T_J, (unless otherwise noted)

PARAMETER	TEST CONDITIONS	MIN	TYP	MAX	UNIT
xTRMPWR Supply Current Section					
xTRMPWR supply current	LVD mode			65	mA
	Disabled terminator			500	μA
1.25 V Regulator Section					
1.25 V regulator	0.5 V ≤ V _{CM} ≤ 2.0 V, See Note 1	1.15	1.25	1.35	V
Regulator source current	V _{REG} = 0 V		-300	-240	mA
Regulator sink current	V _{REG} = 3.0 V	240	300		mA
1.3 V (DIFSENS) Regulator Section					
1.3 V regulator	-5mA ≤ I _{DIFSENS} ≤ 50 μA	1.2	1.3	1.4	V
Short-circuit source current	V _{DIFSENS} = 0 V	-5	-8	-15	mA
Short-circuit sink current	V _{DIFSENS} = 2.75 V	50		200	μA
Differential Termination Section (Applies to each line pair 1–27)					
Differential bias voltage		100		125	mV
Differential impedance		100	105	110	Ω
Common-mode bias voltage	L+ and L– shorted together	1.15	1.25	1.35	V
Common-mode impedance	L+ and L– shorted together, See Note 2	110	140	165	Ω
Disconnected Termination Section					
Output leakage current			10	400	nA
Output capacitance	SE measurement to GND, See Note 3			3	pF
Disconnect Control (DISCNCT1) or (DISCNCT2) and DIFFB Input Section					
DISCNCT threshold voltage		0.8	1.5	2.0	V
DISCNCT input current	V _{DISCNCT} = 0 V and 2.0 V	-30		-10	μA
DIFFB SE to LVD threshold voltage		0.5		0.7	V
DIFFB LVD to HPD threshold voltage		1.9		2.4	V
DIFFB Input current	0 V ≤ V _{DIFFB} ≤ 2.75 V,	-10		10	μA
Low-Voltage Differential (LVD) Status Bit Section					
Source current	V _{LOAD} = 2.4 V		-6	-4	mA
Sink current	V _{LOAD} = 0.4 V	2	5		mA
Thermal Shutdown Section					
Thermal shutdown threshold	For increasing temperature	140	155	170	°C
Thermal shutdown hysteresis			10		°C

NOTE 1: V_{CM} is applied to all L+ and L– lines simultaneously.

NOTE 2: $Z_{CM} = \frac{2.0\text{ V} - 0.5\text{ V}}{I_{VCM(max)} - I_{VCM(min)}}$, V_{CM(max)} = 2.0 V, V_{CM(min)} = 0.5 V

NOTE 3: Ensured by design, not production tested.



UCC5646, UCC5647
27-LINE 3-V – 5-V LVD TERMINATOR
FOR WIDE ULTRA2, ULTRA3, ULTRA160 AND ULTRA320
SLUS386B – FEBRUARY 2000 – REVISED APRIL 2001

pin descriptions

STRMPWR: 2.7 V to 5.25 V power supply for all circuitry except the 1.25-V regulator.

SGND: Ground reference for all circuitry except the 1.25-V regulator.

PTRMPWR: 2.7 V to 5.25 V power supply for the 1.25-V regulator.

PGND: Ground reference for the 1.25-V regulator.

REG: Output of the internal 1.25-V regulator; must be connected to a 4.7- μ F bypass capacitor and a high-frequency, low-ESR 0.01- μ F capacitor to GND.

DIFSENS: Drives the SCSI bus DIFF SENSE line to 1.3 V to detect what types of devices are tied to the bus.

DIFFB: DIFF SENSE input pin. Connect through a 20-k Ω resistor to DIFSENS and through a 0.1- μ F capacitor to GND. Input to comparators that detect what type of drives are connected to the SCSI bus.

DISCNCT1: Disconnect one controls termination lines 10–27 (control and low byte).

DISCNCT2: Disconnect two controls termination lines 1–9 (high byte).

LVD: TTL compatible status bit indicating when low-voltage-differential voltage is present on DIFFB.

L1– thru L27–: Negative lines for the SCSI bus.

L1+ thru L27+: Positive lines for the SCSI bus.



UCC5646, UCC5647 27-LINE 3-V - 5-V LVD TERMINATOR FOR WIDE ULTRA2, ULTRA3, ULTRA160 AND ULTRA320

SLUS386B - FEBRUARY 2000 - REVISED APRIL 2001

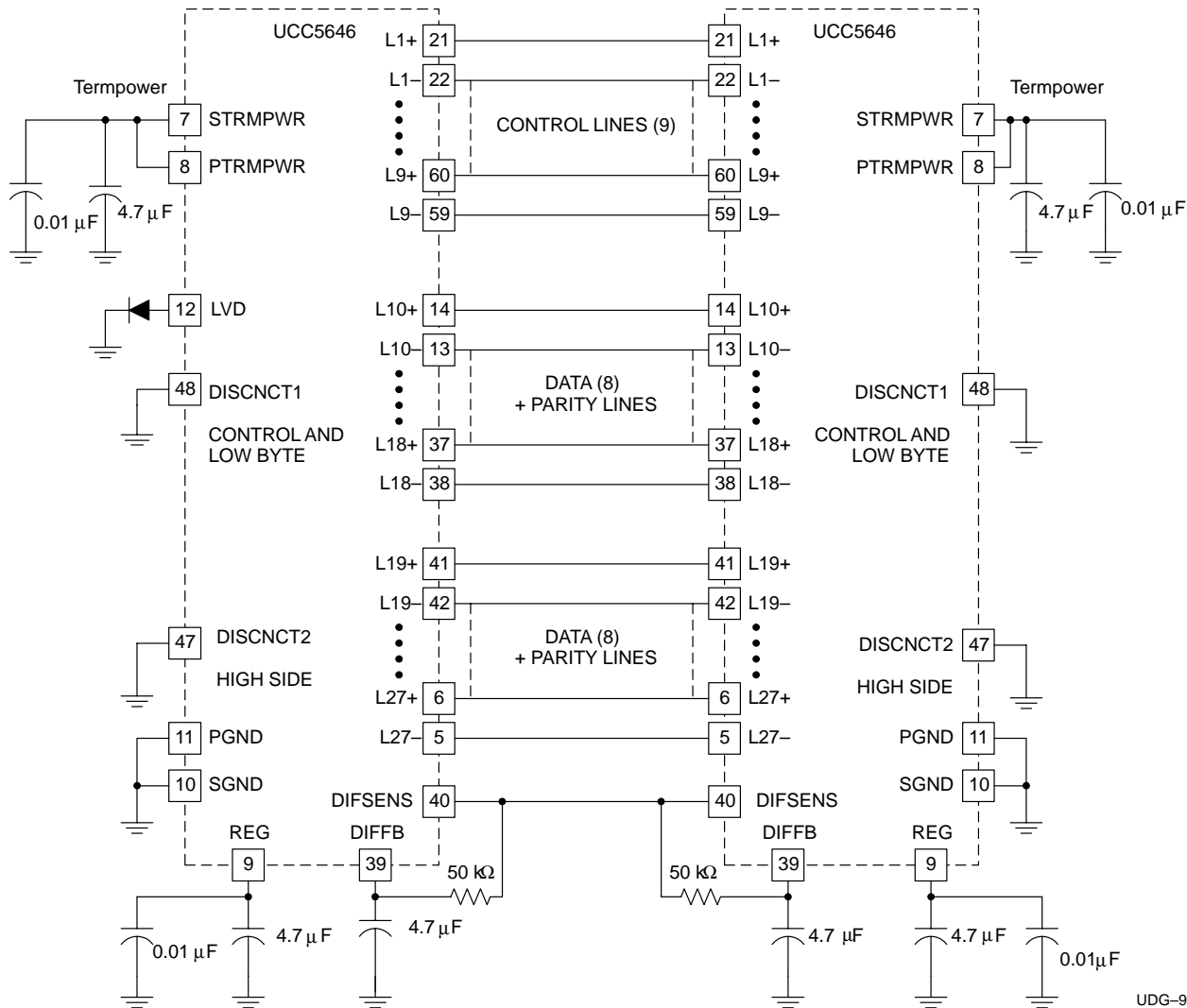

UDG-98202

Figure 1. Typical Application Diagram

PACKAGING INFORMATION

Orderable Device	Status ⁽¹⁾	Package Type	Package Drawing	Pins	Package Qty	Eco Plan ⁽²⁾	Lead/Ball Finish	MSL Peak Temp ⁽³⁾
UCC5646PM	OBSOLETE	LQFP	PM	64		TBD	Call TI	Call TI
UCC5647PM	OBSOLETE	LQFP	PM	64		TBD	Call TI	Call TI

⁽¹⁾ The marketing status values are defined as follows:

ACTIVE: Product device recommended for new designs.

LIFEBUY: TI has announced that the device will be discontinued, and a lifetime-buy period is in effect.

NRND: Not recommended for new designs. Device is in production to support existing customers, but TI does not recommend using this part in a new design.

PREVIEW: Device has been announced but is not in production. Samples may or may not be available.

OBSOLETE: TI has discontinued the production of the device.

⁽²⁾ Eco Plan - The planned eco-friendly classification: Pb-Free (RoHS) or Green (RoHS & no Sb/Br) - please check <http://www.ti.com/productcontent> for the latest availability information and additional product content details.

TBD: The Pb-Free/Green conversion plan has not been defined.

Pb-Free (RoHS): TI's terms "Lead-Free" or "Pb-Free" mean semiconductor products that are compatible with the current RoHS requirements for all 6 substances, including the requirement that lead not exceed 0.1% by weight in homogeneous materials. Where designed to be soldered at high temperatures, TI Pb-Free products are suitable for use in specified lead-free processes.

Green (RoHS & no Sb/Br): TI defines "Green" to mean Pb-Free (RoHS compatible), and free of Bromine (Br) and Antimony (Sb) based flame retardants (Br or Sb do not exceed 0.1% by weight in homogeneous material)

⁽³⁾ MSL, Peak Temp. -- The Moisture Sensitivity Level rating according to the JEDEC industry standard classifications, and peak solder temperature.

Important Information and Disclaimer:The information provided on this page represents TI's knowledge and belief as of the date that it is provided. TI bases its knowledge and belief on information provided by third parties, and makes no representation or warranty as to the accuracy of such information. Efforts are underway to better integrate information from third parties. TI has taken and continues to take reasonable steps to provide representative and accurate information but may not have conducted destructive testing or chemical analysis on incoming materials and chemicals. TI and TI suppliers consider certain information to be proprietary, and thus CAS numbers and other limited information may not be available for release.

In no event shall TI's liability arising out of such information exceed the total purchase price of the TI part(s) at issue in this document sold by TI to Customer on an annual basis.

IMPORTANT NOTICE

Texas Instruments Incorporated and its subsidiaries (TI) reserve the right to make corrections, modifications, enhancements, improvements, and other changes to its products and services at any time and to discontinue any product or service without notice. Customers should obtain the latest relevant information before placing orders and should verify that such information is current and complete. All products are sold subject to TI's terms and conditions of sale supplied at the time of order acknowledgment.

TI warrants performance of its hardware products to the specifications applicable at the time of sale in accordance with TI's standard warranty. Testing and other quality control techniques are used to the extent TI deems necessary to support this warranty. Except where mandated by government requirements, testing of all parameters of each product is not necessarily performed.

TI assumes no liability for applications assistance or customer product design. Customers are responsible for their products and applications using TI components. To minimize the risks associated with customer products and applications, customers should provide adequate design and operating safeguards.

TI does not warrant or represent that any license, either express or implied, is granted under any TI patent right, copyright, mask work right, or other TI intellectual property right relating to any combination, machine, or process in which TI products or services are used. Information published by TI regarding third-party products or services does not constitute a license from TI to use such products or services or a warranty or endorsement thereof. Use of such information may require a license from a third party under the patents or other intellectual property of the third party, or a license from TI under the patents or other intellectual property of TI.

Reproduction of information in TI data books or data sheets is permissible only if reproduction is without alteration and is accompanied by all associated warranties, conditions, limitations, and notices. Reproduction of this information with alteration is an unfair and deceptive business practice. TI is not responsible or liable for such altered documentation.

Resale of TI products or services with statements different from or beyond the parameters stated by TI for that product or service voids all express and any implied warranties for the associated TI product or service and is an unfair and deceptive business practice. TI is not responsible or liable for any such statements.

Following are URLs where you can obtain information on other Texas Instruments products and application solutions:

Products		Applications	
Amplifiers	amplifier.ti.com	Audio	www.ti.com/audio
Data Converters	dataconverter.ti.com	Automotive	www.ti.com/automotive
DSP	dsp.ti.com	Broadband	www.ti.com/broadband
Interface	interface.ti.com	Digital Control	www.ti.com/digitalcontrol
Logic	logic.ti.com	Military	www.ti.com/military
Power Mgmt	power.ti.com	Optical Networking	www.ti.com/opticalnetwork
Microcontrollers	microcontroller.ti.com	Security	www.ti.com/security
		Telephony	www.ti.com/telephony
		Video & Imaging	www.ti.com/video
		Wireless	www.ti.com/wireless

Mailing Address: Texas Instruments
Post Office Box 655303 Dallas, Texas 75265