



UCC284-5/-12/-ADJ
UCC384-5/-12/-ADJ

Low Dropout 0.5A Negative Linear Regulator

FEATURES

- Precision Negative Series Pass Voltage Regulation
- 0.2V Drop Out at 0.5A
- Wide Input voltage Range -3.2V to -15V
- Low Quiescent Current Irrespective of Load
- Simple Logic Shutdown Interfacing
- -5V, -12V and Adjustable Output
- 2.5% Duty Cycle Short Circuit Protection
- Remote Load Sensing for Accurate Load Regulation
- 8-Pin DP Package

BLOCK DIAGRAM

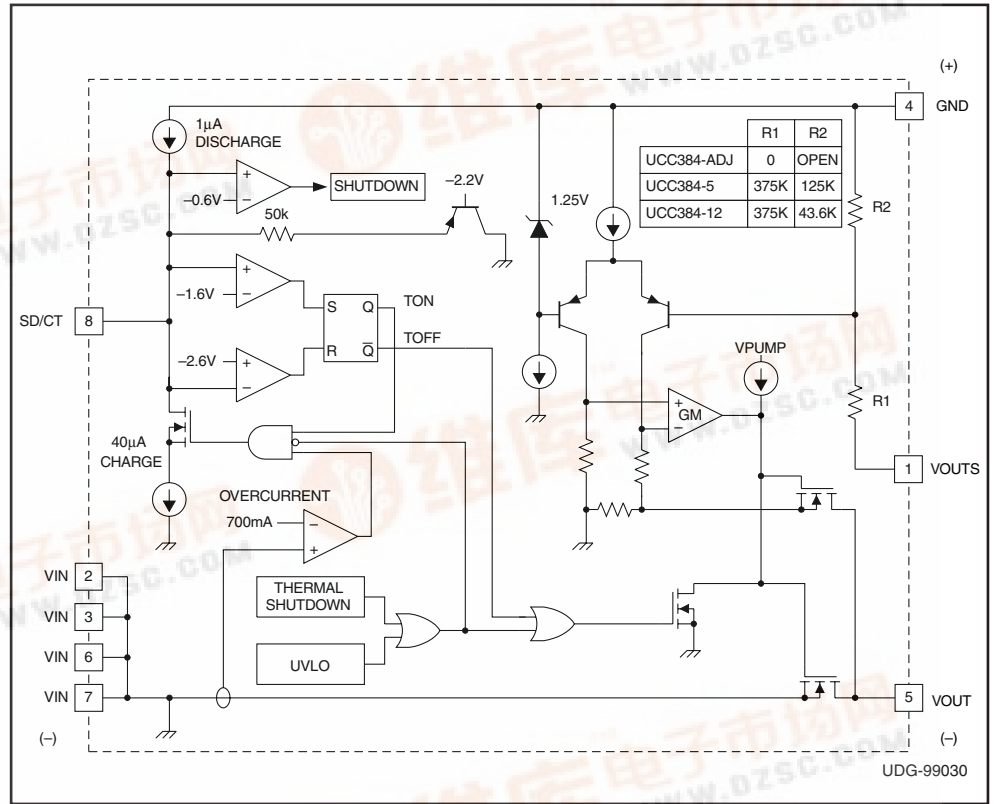

DESCRIPTION

The UCC384 family of negative linear series pass regulators is tailored for low drop out applications where low quiescent power is important. Fabricated with a BCDMOS technology ideally suited for low input to output differential applications, the UCC384 will pass 0.5A while requiring only 0.2V of input voltage headroom. Drop out voltage decreases linearly with output current, so that drop out at 50mA is less than 20mV.

Quiescent current consumption for the device under normal (non-drop out) conditions is typically 200µA. An integrated charge pump is internally enabled only when the device is operating near drop out with low VIN. This guarantees that the device will meet the drop out specifications even for maximum load current and a VIN of -3.2V with only a modest increase in quiescent current. Quiescent current is always less than 350µA, with the charge pump enabled. Quiescent current of the UCC384 does not increase with load current.

Short circuit current is internally limited. The device responds to a sustained over current condition by turning off after a T_{ON} delay. The device then stays off for a period, T_{OFF}, that is 40 times the T_{ON} delay. The device then begins pulsing on and off at the T_{ON}/T_{OFF} duty cycle of 2.5%. This drastically reduces the power dissipation during short circuit such that heat sinking, if at all required, must only accommodate normal operation. An external capacitor sets the on time. The off time is always 40 times T_{ON}.

The UCC384 can be shutdown to 45µA (maximum) by pulling the SD/CT pin more positive than -0.6V. To allow for simpler interfacing, the SD/CT pin may be pulled up to +6V above the ground pin without turning on clamping diodes.

Internal power dissipation is further controlled with thermal overload protection circuitry. Thermal shutdown occurs if the junction temperature exceeds 140°C. The chip will remain off until the temperature has dropped 20°C.

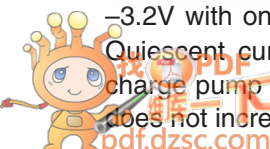

ABSOLUTE MAXIMUM RATINGS

Supply Voltage, VIN -16V
 Shutdown Voltage, SD/CT +6V to -5V
 Storage Temperature -65°C to +150°C
 Junction Temperature -55°C to +150°C
 Lead Temperature (Soldering, 10 sec.) +300°C

All voltages are with respect to ground. Currents are positive into, negative out of the specified terminal. All voltages are with respect to ground. Consult Packaging Section of Databook for thermal limitations and considerations of packages.

CONNECTION DIAGRAM

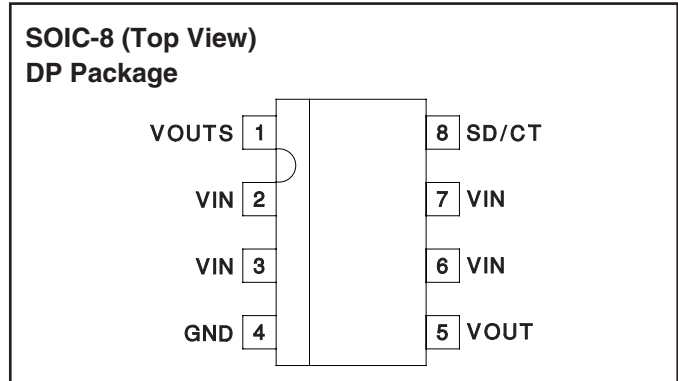

ELECTRICAL CHARACTERISTICS: Unless otherwise specified, $T_A = 0^\circ\text{C}$ to 70°C for the UCC384 and -40°C to 85°C for the UCC284, $V_{IN} = V_{OUT} - 1.5\text{V}$, $I_{OUT} = 0\text{mA}$, $C_{OUT} = 4.7\mu\text{F}$, and $C_T = 0.015\mu\text{F}$. For UCC384-ADJ, V_{OUT} is set to -3.3V . $T_J = T_A$.

PARAMETER	TEST CONDITIONS	MIN	TYP	MAX	UNITS
UCC384-5 Fixed -5V 0.5A Regulation Section					
Output Voltage	$T_A = 25^\circ\text{C}$	-5.075	-5	-4.925	V
	Over all conditions	-5.100		-4.850	V
Line Regulation	$V_{IN} = -5.3\text{V}$ to -15V		1.5	10	mV
Load Regulation	$I_{OUT} = 0\text{mA}$ to 0.5A		0.1	0.25	%
Output Noise Voltage	$T_A = 25^\circ\text{C}$, BW = 10Hz to 10kHz		200		μVRMS
Drop Out Voltage, $V_{OUT} - V_{IN}$	$I_{OUT} 0.5\text{A}$, $V_{OUT} = -4.8\text{V}$		0.20	0.50	V
	$I_{OUT} 50\text{mA}$, $V_{OUT} = -4.8\text{V}$		20	50	mV
UCC384-5 Fixed -5V 0.5A Power Supply Section					
Input Voltage Range		-15		-5.2	V
Quiescent Current Charge Pump On	$V_{IN} = -4.85\text{V}$ (Note 1)		280	350	μA
Quiescent Current	$V_{IN} = -15\text{V}$		200	250	μA
Quiescent Current in Shutdown	$V_{IN} = -15\text{V}$, SD/CT = 0V, No Load		24	45	μA
Shutdown Threshold	At Shutdown Pin	-1.0	-0.6	-0.4	V
Shutdown Input Current	SD/CT = 0V	5	17	25	μA
Output Leakage in Shutdown	$V_{IN} = -15\text{V}$, $V_{OUT} = 0$, 25°C		1	10	μA
	Over Temperature			50	μA
Over Temperature Shutdown			140		$^\circ\text{C}$
Over Temperature Hysteresis			20		$^\circ\text{C}$
UCC384-5 Fixed -5V 0.5A Current Limit Section					
Peak Current Limit	$V_{OUT} = 0\text{V}$	0.7	1.1	1.5	A
Over Current Threshold		0.55	0.7	0.9	A
Current Limit Duty Cycle	$V_{OUT} = 0\text{V}$		2.5	4	%
Overcurrent Time Out, T_{ON}	$V_{OUT} = 0\text{V}$	300	450	650	μs
UCC384-12 Fixed 12V 0.5A Regulation Section					
Output Voltage	$T_A = 25^\circ\text{C}$	-12.18	-12	-11.82	V
	Over all conditions	-12.24		-11.64	V
Line Regulation	$V_{IN} = -12.5\text{V}$ to -15V		5	15	mV
Load Regulation	$I_{OUT} = 0\text{mA}$ to 0.5A		0.1	0.3	%
Output Noise Voltage	$T_A = 25^\circ\text{C}$, BW = 10Hz to 10kHz		200		μVRMS
Drop Out Voltage, $V_{OUT} - V_{IN}$	$I_{OUT} 0.5\text{A}$, $V_{OUT} = -11.6\text{V}$		0.15	0.5	V
	$I_{OUT} 50\text{mA}$, $V_{OUT} = -11.6\text{V}$		15	50	mV

UCC284-5/-12/-ADJ
UCC384-5/-12/-ADJ

ELECTRICAL CHARACTERISTICS: Unless otherwise specified, $T_A = 0^\circ\text{C}$ to 70°C for the UCC384 and -40°C to 85°C for the UCC284, $V_{IN} = V_{OUT} - 1.5\text{V}$, $I_{OUT} = 0\text{mA}$, $C_{OUT} = 4.7\mu\text{F}$, and $C_T = 0.015\mu\text{F}$. For UCC384-ADJ, V_{OUT} is set to -3.3V . $T_J = T_A$.

PARAMETER	TEST CONDITIONS	MIN	TYP	MAX	UNITS
UCC384-12 Fixed -12V 0.5A Power Supply Section					
Input Voltage Range		-15		-12.2	V
Quiescent Current	$V_{IN} = -15\text{V}$		220	350	μA
Quiescent Current in Shutdown	$V_{IN} = -15\text{V}$, $\text{SD/CT} = 0\text{V}$, No Load		24	45	μA
Shutdown Threshold	At Shutdown Pin	-1.0	-0.6	-0.4	V
Shutdown Input Current	$\text{SD/CT} = 0\text{V}$	5	17	25	μA
Output Leakage in Shutdown	$V_{IN} = -15\text{V}$, $V_{OUT} = 0$, 25°C		1	10	μA
	Over Temperature			50	μA
Over Temperature Shutdown			140		$^\circ\text{C}$
Over Temperature Hysteresis			20		$^\circ\text{C}$
UCC384-12 Fixed -12V 0.5A Current Limit Section					
Peak Current Limit	$V_{OUT} = 0\text{V}$	0.7	1.2	1.5	A
Over Current Threshold		0.55	0.7	0.9	A
Current Limit Duty Cycle	$V_{OUT} = 0\text{V}$		2.5	4	%
Over Current Time Out, T_{ON}	$V_{OUT} = 0\text{V}$	300	450	650	μs
UCC384-ADJ Adjustable 0.5A Regulation Section					
Reference Voltage	$T_A = 25^\circ\text{C}$	-1.27	-1.25	-1.23	V
	Over Temperature	-1.275		-1.215	V
Line Regulation	$V_{IN} = -3.5\text{V}$ to -15V , $V_{OUT} = V_{OUTS}$		0.5	3	mV
Load Regulation	$I_{OUT} = 0\text{mA}$ to 0.5A		0.1	0.18	%
Output Noise Voltage	$T_A = 25^\circ\text{C}$, $\text{BW} = 10\text{Hz}$ to 10kHz		200		μVRMS
Drop Out Voltage, $V_{OUT} - V_{IN}$	$I_{OUT} 0.5\text{A}$, $V_{OUT} = -3.15\text{V}$		0.25	0.5	V
	$I_{OUT} 50\text{mA}$, $V_{OUT} = 3.15\text{V}$		25	50	mV
Sense Pin Input Current			100	250	nA
UCC384-ADJ Adjustable 0.5A Power Supply Section					
Input Voltage Range		-15		-3.5	V
Undervoltage Lockout		-3.2		-2.7	V
Quiescent Current Charge Pump On	$V_{IN} = -3.15\text{V}$ (Note 1)		200	350	μA
Quiescent Current	$V_{IN} = -15\text{V}$		200	250	μA
Quiescent Current in Shutdown	$V_{IN} = -15\text{V}$, $\text{SD/CT} = 0\text{V}$, No Load		24	45	μA
Shutdown Threshold	At Shutdown Pin	-1.0	-0.6	-0.4	V
Shutdown Input Current	$\text{SD/CT} = 0\text{V}$	5	17	25	μA
Output Leakage in Shutdown	$V_{IN} = -15\text{V}$, $V_{OUT} = 0$, 25°C		1	10	μA
	Over Temperature			50	μA
Over Temperature Shutdown			140		$^\circ\text{C}$
Over Temperature Hysteresis			20		$^\circ\text{C}$
UCC384-ADJ Adjustable 0.5A Current Limit Section					
Peak Current Limit	$V_{OUT} = 0\text{V}$	0.7	1.1	1.5	A
Over Current Threshold		0.55	0.7	0.9	A
Current Limit Duty Cycle	$V_{OUT} = 0\text{V}$		2.5	4	%
Over Current Time Out, T_{ON}	$V_{OUT} = 0\text{V}$	300	450	650	μs

Note 1: Internal Charge Pump is enabled only for drop-out condition with low V_{IN} . Only in this condition is the Charge Pump required to provide additional output FET gate drive to maintain drop-out specifications. For conditions where the Charge Pump is not required, it is disabled, which lowers overall device power consumption.

PIN DESCRIPTIONS

GND: This is the low noise ground reference input. All voltages are measured with respect to the GND pin.

SD/CT: This is the shutdown pin and also the short circuit timing pin. Pulling this pin more positive than -0.6V will put the circuit in a low current shutdown mode. Placing a timing capacitor between this pin and GND will set the short circuit charging time, TON during an overcurrent condition. During an overcurrent condition, the output will be pulsed at approximately a 2.5% duty cycle.

Note: The CT capacitor must be connected between this pin and GND, not VIN, to assure that the SD/CT pin is not pulled significantly negative during power-up. This pin should not be externally driven more negative than -5V or the device will be damaged.

VIN: This is the negative input supply. Bypass this pin to GND with at least $1\mu\text{F}$ of low ESR, ESL capacitance.

VOUT: Regulated negative output voltage. A single $4.7\mu\text{F}$ capacitor should be connected between this pin and GND. Smaller value capacitors can be used for light loads, but this will degrade the load step performance of the regulator.

VOUTS: This is the feedback pin for sensing the output of the regulator. For the UCC384-5 and UCC384-12 versions, VOUTS can be connected directly to VOUT. If the load is placed at a considerable distance from the regulator, the VOUTS lead can be used as a Kelvin connection to minimize errors due to lead resistance. Connecting VOUTS at the load will move the resistance of the VOUT wire into the control loop of the regulator, thereby effectively canceling the IR drop associated with the load path.

When using a UCC384-ADJ, the output voltage can be programmed by placing a resistor divider across the output to GND. VOUTS is connected to the center tap of the divider providing the feedback for the regulator. This configuration is shown in Fig. 1.

APPLICATION INFORMATION

Overview

The UCC384 family of NEGATIVE low dropout linear (LDO) regulators provides a regulated output voltage for applications with up to 0.5A of load current. The regulators feature a low dropout voltage and short circuit protection, making their use ideal for demanding applications requiring fault protection.

Programming the output voltage on the UCC384

The UCC384-5 and UCC384-12 have fixed output voltages of -5V and -12V respectively. Connecting VOUTS to VOUT will give the proper output voltage with respect to ground.

The UCC384-ADJ can be programmed for any output voltage between -1.25V and -15V . This is easily accomplished with the addition of an external resistor divider connected between GND and VOUT with VOUTS connected to the center tap of the divider. For an output of -1.25V , no resistors are needed and VOUTS is connected directly to VOUT. The regulator input voltage cannot be more positive than the UVLO threshold, or approximately -3V . Thus, low drop out cannot be achieved when programming the output voltage more positive than approximately -3.3V . A typical Application circuit is shown in Fig. 1.

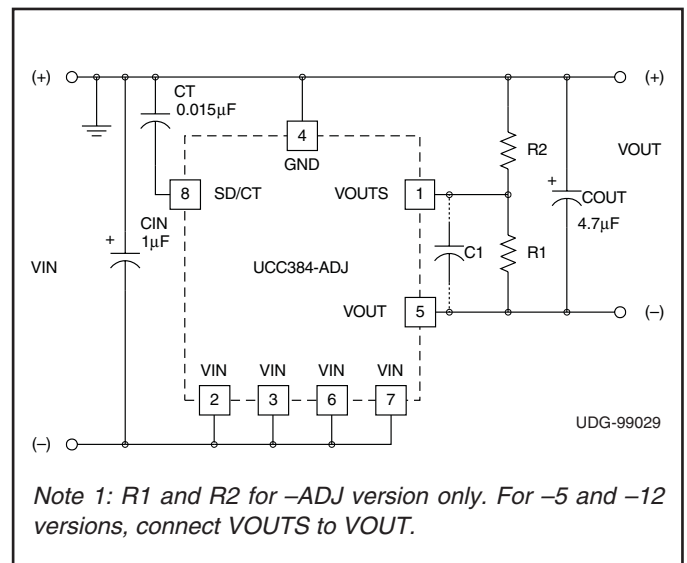

Figure 1. Typical application schematic.

For the UCC384-ADJ, the output voltage is programmed by the following equation:

$$VOUT = -1.25 \cdot \left(1 + \frac{R1}{R2} \right) \quad (1)$$

When R1 or R2 are selected to be greater than about $100\text{k}\Omega$, a small ceramic capacitor should be placed across R1 to cancel the input pole created by R1 and the parasitic capacitance appearing on VOUTS. Values of approximately 20pF should be adequate.

APPLICATION INFORMATION (cont.)

Dropout Performance

The UCC384 is tailored for low dropout applications where low quiescent power is important. Fabricated with a BCDMOS technology ideally suited for low input to output differential applications, the UCC384 will pass 0.5A while requiring only 0.2V of headroom. The dropout voltage is dependent on operating conditions such as load current, input and load voltages, and temperature. The UCC384 achieves a low $R_{DS(on)}$ through the use of an internal charge-pump that drives the MOSFET gate.

Fig. 2 shows typical dropout voltages versus output voltage for the UCC384-5V and -12V versions as well as the UCC384-ADJ version programmed between -3.3V and -15V. Since the dropout voltage is also affected by output current, Fig. 3 shows typical dropout voltages vs. load current for different values of V_{OUT} .

Operating temperatures also effect the $R_{DS(on)}$ and the dropout voltage of the UCC384. Fig. 4 shows typical dropout voltages for the UCC384 over temperature under a full load of 0.5A.

Short Circuit Protection

The UCC384 provides unique short circuit protection circuitry that reduces power dissipation during a fault. When an overcurrent condition is detected, the device enters a pulsed mode of operation, limiting the output to a 2.5% duty cycle. This will reduce the heat sink requirements during a fault. The operation of the UCC384 during an overcurrent condition is shown in Fig. 5.

UCC384 Short Circuit Timing

During normal operation the output voltage is in regulation and the SD/CT pin is held to -1.5V via a 50k Ω internal source impedance. If the output current rises above the Overcurrent Threshold, the CT capacitor will be charged by a 40 μ A current sink. The voltage on the SD/CT pin will move in a negative direction with respect to GND.

During an overcurrent condition, the regulator will actively limit the maximum output current to the Peak Current Limit. This will limit the output voltage of the regulator to:

$$V_{OUT} = I_{PEAK} \cdot R_L$$

If the output current stays above the Overcurrent Threshold, the voltage on the SD/CT pin will reach -2.6V with respect to GND and the output will turn off. The CT capacitor is then discharged by a 1 μ A current source. When the voltage on the SD/CT pin reaches -1.6V with respect to GND, the output will turn back on. This process will repeat until the output current falls below the Overcurrent Threshold.

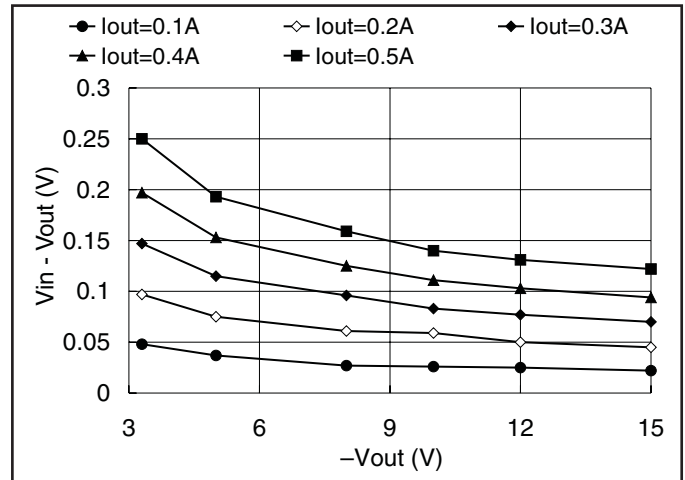

Figure 2. Dropout voltage vs. output voltage.

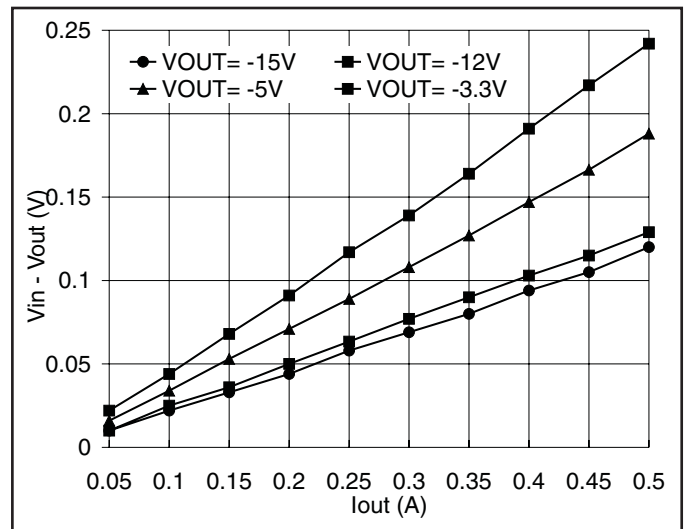

Figure 3. Dropout voltage vs. load current.

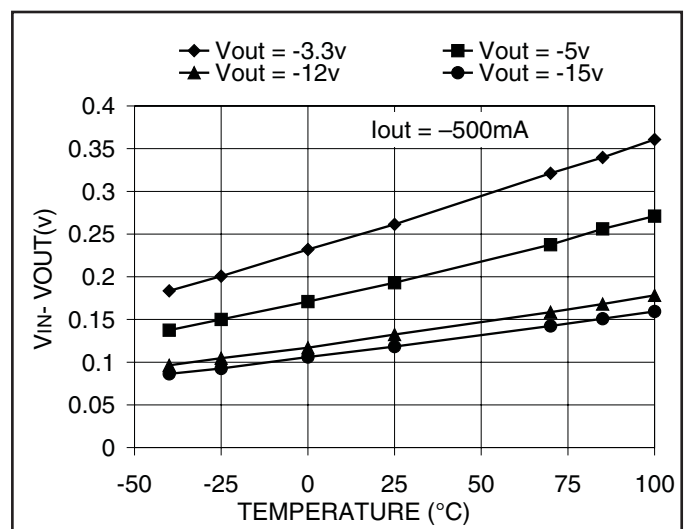
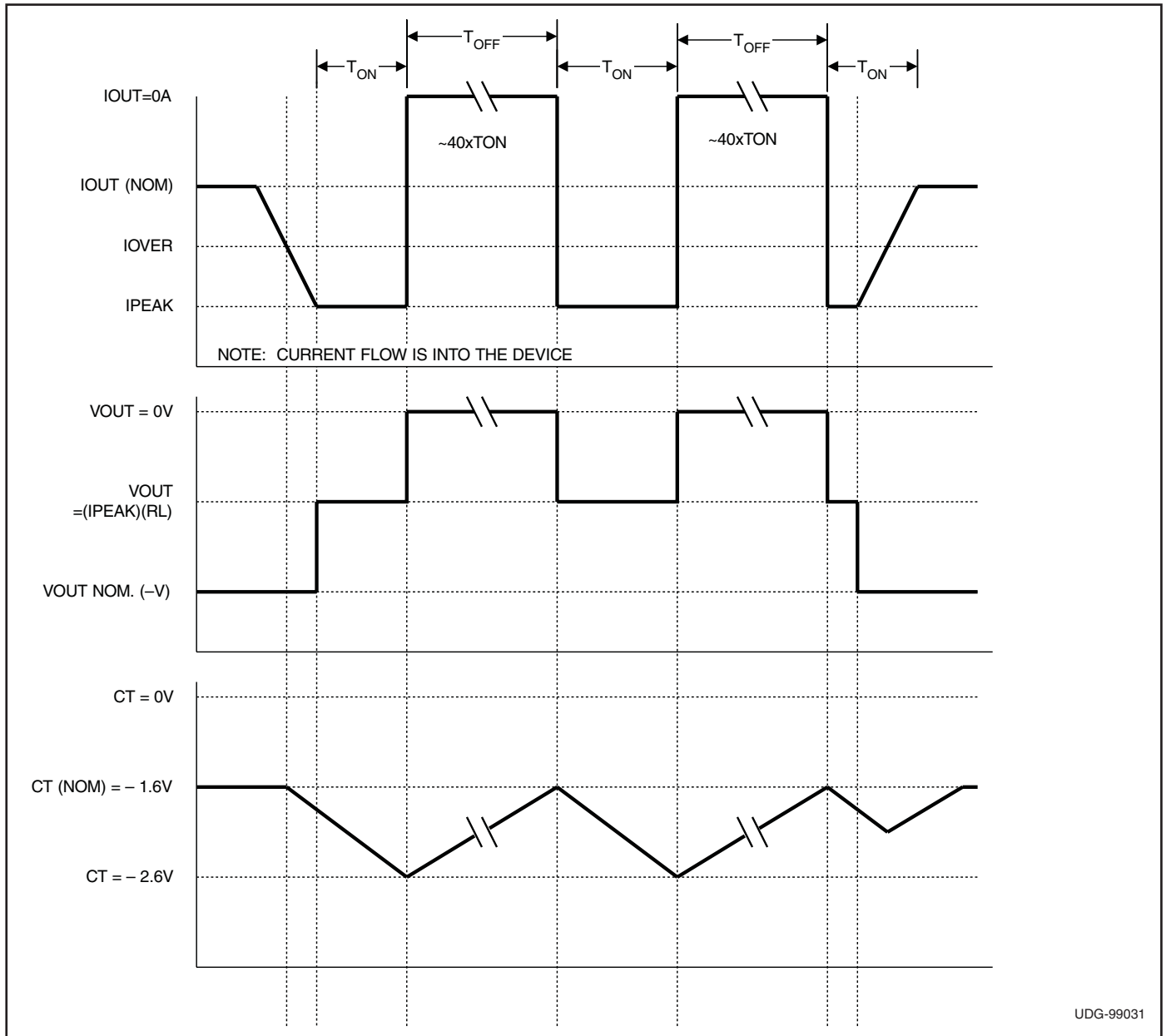

Figure 4. Dropout voltage vs. temperature.

APPLICATION INFORMATION (cont.)



UDG-99031

Figure 5. Short circuit timing.

T_{ON} , the time the output is on during an overcurrent condition is determined by the following equation:

$$T_{ON} = C_T (\mu F) \cdot \frac{1V}{40\mu A} \text{ seconds} \quad (2)$$

T_{OFF} , the time the output is off during an overcurrent condition is determined by the following equation:

$$T_{OFF} = C_T (\mu F) \cdot \frac{1V}{1\mu A} \text{ seconds} \quad (3)$$

Capacitive Loads

A capacitive load on the regulator's output will appear as a short circuit during start-up. If the capacitance is too large, the output voltage will not come into regulation during the initial T_{ON} period and the UCC384 will enter a pulsed mode operation. For a constant current load the maximum allowed output capacitance is calculated as follows:

$$C_{OUT}(\max) = \quad (4)$$

$$[I_{PEAK}(A) - I_{LOAD}(A)] \cdot \frac{T_{ON}(\text{sec})}{V_{OUT}(V)} \text{ Farads}$$

APPLICATION INFORMATION (cont.)

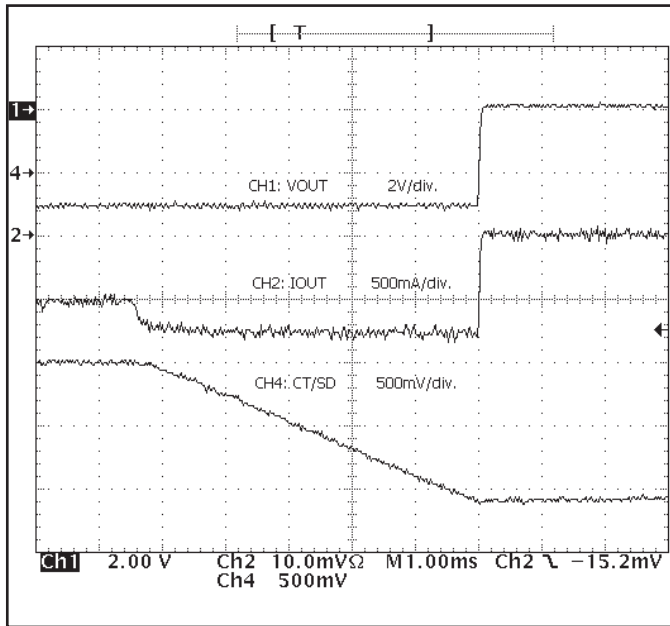

Figure 6. UCC384-ADJ operation during overcurrent condition (1ms/div).

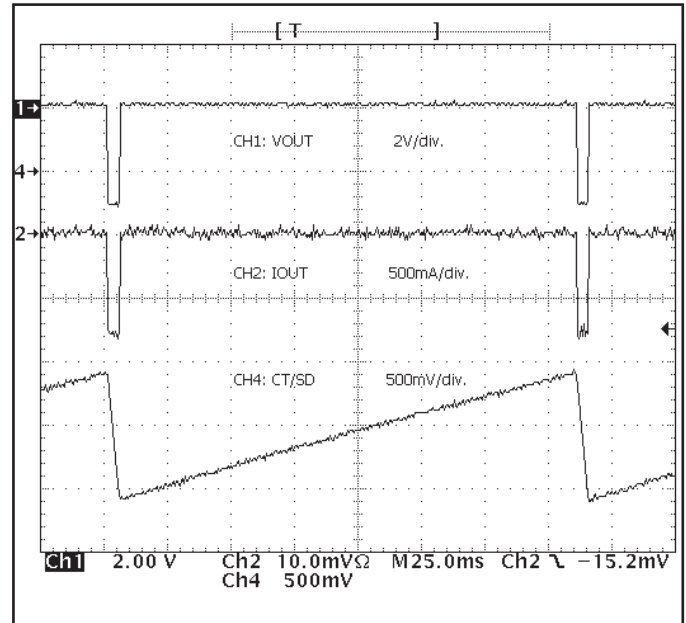

Figure 7. UCC384-ADJ operation during overcurrent condition (25ms/div.).

For worst case calculations, the minimum value for TON should be used, which is based on the value of CT capacitor selected. For a resistive load the maximum output capacitor can be estimated as follows:

$$C_{OUT}(\text{max}) = \frac{T_{ON}(\text{sec})}{R_{LOAD}(\Omega) \cdot \ln \left(\frac{1}{1 - \frac{V_{OUT}(V)}{I_{MAX}(A) \cdot R_{LOAD}(\Omega)}} \right)} \text{ Farads} \quad (5)$$

Fig. 6 and Fig. 7 are oscilloscope photos of the UCC384-ADJ operating during an overcurrent condition. Fig. 6 shows operation of the circuit as the output current initially rises above the Overcurrent Threshold. This is shown on a 1ms/div. scale. Fig. 7 shows operation of the same circuit on a 25ms/div. scale allowing us to see one complete cycle of operation during an overcurrent condition.

Shutdown Feature of the UCC384

The shutdown feature of the UCC384 allows the device to be placed in a low quiescent current mode. The UCC384 is shut down by pulling the SD/CT pin more positive than -0.6V with respect to GND. Fig. 8 shows how a shutdown circuit can be configured for the UCC384 using a standard TTL signal to control it.

Controlling the SD/CT Pin

Forcing the SD/CT pin to any fixed voltage will affect the operation of the circuit. As mentioned before, pulling the SD/CT pin more positive than -0.6V will put the circuit in a shutdown mode, limiting the quiescent current to less than 45µA. Pulling this pin more positive than +6V with respect to GND will damage the device.

Forcing the SD/CT pin to any fixed voltage between -0.6V and -2.6V with respect to GND will cause the circuit to ignore an overcurrent condition. In this situation, the output will not be pulsed at a 2.5% duty cycle, but the output current will still be limited to the Peak Current Limit. This circuit maybe used where a fixed current limit is needed, while a 2.5% duty cycle is undesirable. The UCC384 will supply a maximum current in this configuration as long as the temperature of the device does not exceed the Over Temperature Shutdown. This will be determined by the Peak Current being supplied, the input and output voltages, and the type of heat sink being used. Thermal Design will be discussed later on in this data sheet.

Forcing the SD/CT pin to a voltage level between approximately -2.6V and -5V with respect to GND will turn the output off completely. The output will stay off as long as the voltage is applied. Pulling this pin more negative than -5V with respect to GND will damage the device.

APPLICATION INFORMATION (cont.)

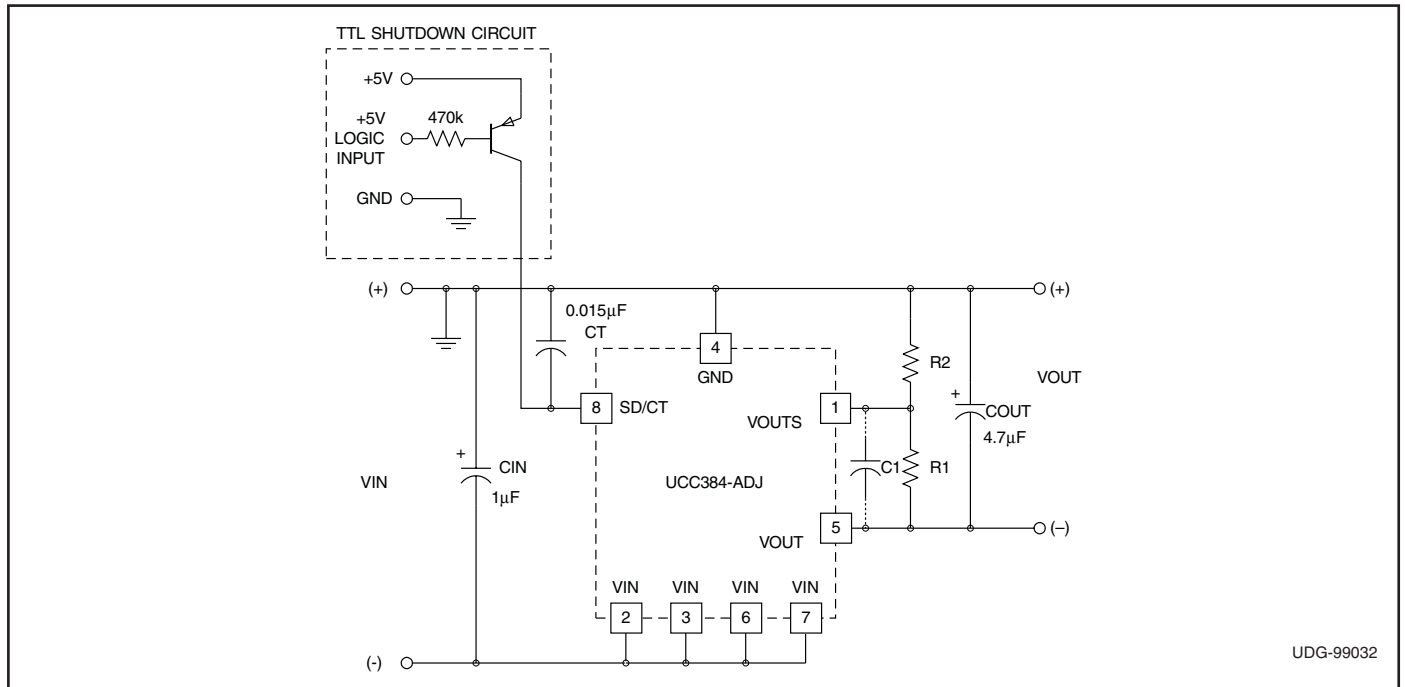

Figure 8. TTL controlled shutdown circuit for the UCC384.

Fig. 9 shows typical VOUT leakage current as a function of temperature during shutdown.

VIN to VOUT Delay

During power-up there is a delay between VIN and VOUT. The majority of this delay time is due to the charging time of the CT capacitor. When VIN moves more negative than the UVLO of the device with respect to GND, the CT capacitor will start to charge. A 17µA current sink is used only during power-up to charge the CT capacitor. When the voltage on the SD/CT pin reaches approximately -1.6V with respect to GND, the output will turn on and regulate. The larger the value of

the CT capacitor, the greater the delay time between VIN and VOUT. Fig. 10 shows the VIN to VOUT startup delay, approximately 16ms, for a circuit with CT = 0.22µF.

Shorter delay times can be achieved with a smaller CT capacitor. The problem with a smaller CT capacitor is that with a very large load, the circuit may stay in overcurrent mode and never turn on. A circuit with a large capacitive load will need a large CT capacitor to operate properly.

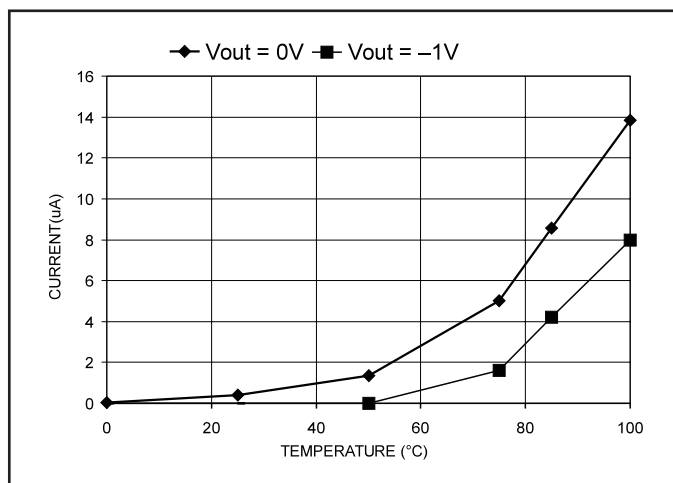

Figure 9. VOUT leakage current in shutdown (VIN = 15V)

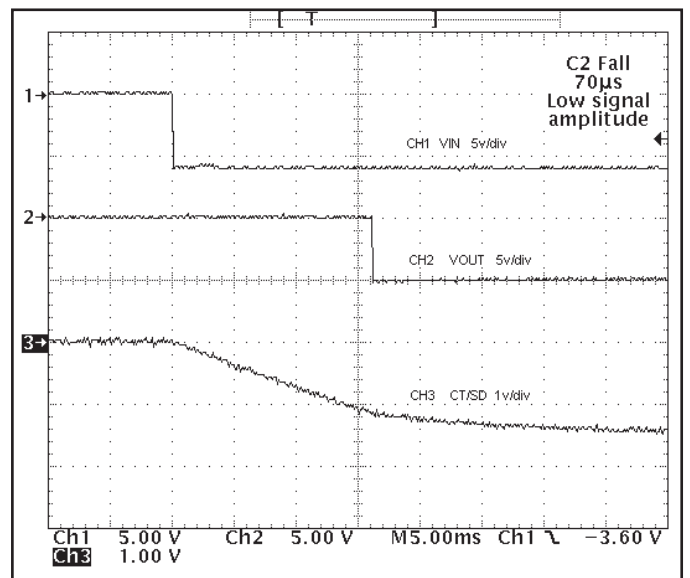

Figure 10. VIN to VOUT delay time during power-up with CT = 0.22 µF

APPLICATION INFORMATION (cont.)

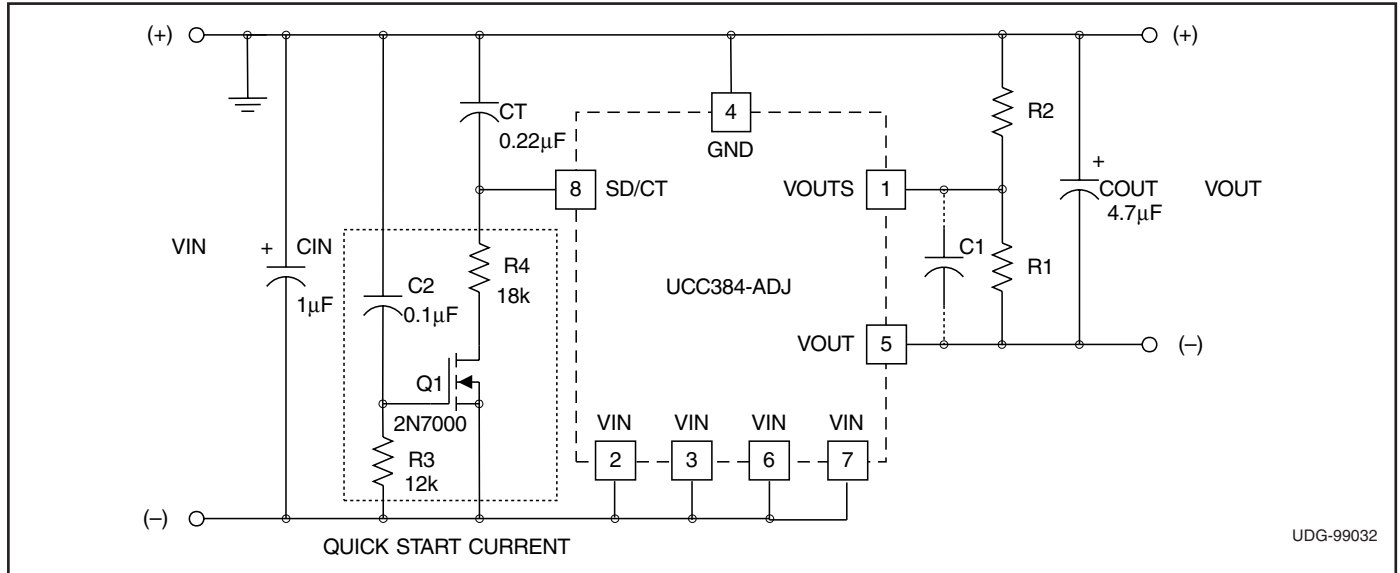

Figure 11. Quick start-up circuit for UCC384.

One way to shorten the delay from VIN to VOUT during power-up, is by the use of the Quick Start-up circuit shown in Fig. 11.

With the Quick Start-Up circuit, the delay time between VIN and VOUT during start-up can be reduced dramatically. Fig. 12 shows that with the Quick Start-Up circuit, the VIN to VOUT delay time has been reduced to approximately 1ms.

Operation of the Quick Start-Up Circuit

During normal start-up, the UCC384 will not turn on until the voltage on the SD/CT pin reaches approximately -1.6V with respect to ground. It will take a certain amount of time for the CT capacitor to charge to this point. For a circuit that has a very large load, the CT capacitor will also need to be large in order for the overcurrent timing to work properly. A large value of capacitance on the SD/CT pin will increase the VIN to VOUT delay time.

The quick start-up circuit uses Q1 to quickly pull the SD/CT pin in a negative direction during start-up, thus decreasing the VIN to VOUT delay time. When VIN is applied to the circuit, Q1 turns on and starts to charge the CT capacitor. The current pulled through R4 will determine the rate at which CT is charged. R4 can be calculated as follows:

$$R4 = \frac{V_{IN}(V) \cdot T_D(\text{sec})}{1.6 \cdot CT(F)} \text{ Ohms} \quad (6)$$

TD is the approximate VIN to VOUT delay time you wish to achieve.

Q1 will need to be turned off after a fixed time to prevent the SD/CT pin from going too far negative with respect to GND. If the SD/CT pin is allowed to go too far negative with respect to GND, the output will turn off again or possibly even damage the SD/CT pin. The maximum amount of time that Q1 should be allowed to be on is referred to as TM and can be calculated as follows:

$$T_M = \frac{2.6}{1.6} \cdot T_D \text{ Seconds} \quad (7)$$

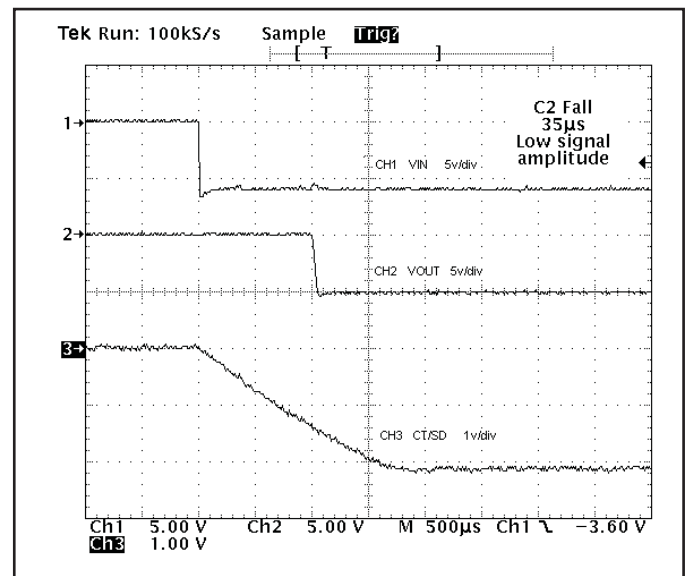

Figure 12. VIN to VOUT delay time with quick start-up circuit.

APPLICATION INFORMATION (cont.)

R3 along with C2 set the time that Q1 is allowed to be on. Since T_M is the maximum amount of time that Q1 should be allowed to stay on, an added safety margin may be to use $0.9 \cdot T_M$ instead. This will ensure that Q1 is turned off in the proper amount of time. With a chosen value for C2, R3 can be calculated as follows:

$$R3 = \frac{0.9 \cdot T_M (\text{sec})}{C2(F) \cdot \ln \left(1 - \frac{V_{IN}(V) - 1.6}{V_{IN}(V)} \right)} \text{ Ohms} \quad (8)$$

After the CT capacitor has charged up for a time equal to $0.9 \cdot T_M$, Q1 will turn off and allow the SD/CT pin to be pulled back to $-1.5V$ with respect to GND through a 50k resistor. At this point, the SD/CT pin can be used by the UCC384 overcurrent timing control.

Minimum V_{IN} To V_{OUT} Delay Time

Although it may desirable to have as short a delay time as possible, a small portion of this delay time is fixed by the UCC384 and cannot be shortened. This is shown in Fig. 13, where the CT capacitor has been removed from the circuit completely, giving a fixed V_{IN} to V_{OUT} delay of approximately $150\mu s$ for a circuit with $V_{IN} = -6V$ and $V_{OUT} = -5V$.

Thermal Design

The Packaging Information section of this data book contains reference material for the thermal ratings of various packages. The section also includes an excellent article entitled *Thermal Characteristics of Surface Mount Packages*, which is the basis for the following discussion.

Thermal design for the UCC384 includes two modes of operation, normal and pulsed. In normal mode, the linear regulator and heat sink must dissipate power equal to the maximum forward voltage drop multiplied by the maximum load current. Assuming a constant current load, the expected heat rise at the regulator's junction can be calculated as follows:

$$T_{RISE} = P_{DISS} \cdot (\theta_{jc} + \theta_{ca}) \text{ } ^\circ C \quad (9)$$

Theta (θ) is the thermal resistance and P_{DISS} is the power dissipated. The junction to case thermal resistance (θ_{jc}) of the SOIC-8 DP package is $22^\circ C/W$. In order to prevent the regulator from going into thermal

shutdown, the case to ambient thermal resistance (θ_{ja}) must keep the junction temperature below $150^\circ C$. If the UCC384 is mounted on a 5 square inch pad of 1 ounce copper, for example, the thermal resistance (θ_{ja}) becomes $40\text{-}70^\circ C/W$. If a lower thermal resistance is required by the application, the device heat sinking would need to be improved.

When the UCC384 is in a pulsed mode, due to an overcurrent condition, the maximum average power dissipation is calculated as follows:

$$P_{AVE} = [V_{IN}(V) - V_{OUT}(V)] \cdot I_{PEAK}(A) \cdot \left(\frac{T_{ON}(\text{sec})}{40 \cdot T_{ON}(\text{sec})} \right) \text{ Watts} \quad (10)$$

As seen in equation 10, the average power during a fault is reduced dramatically by the duty cycle, allowing the heat sink to be sized for normal operation. Although the peak power in the regulator during the T_{ON} period can be significant, the thermal mass of the package will generally keep the junction temperature from rising unless the T_{ON} period is increased to several milliseconds.

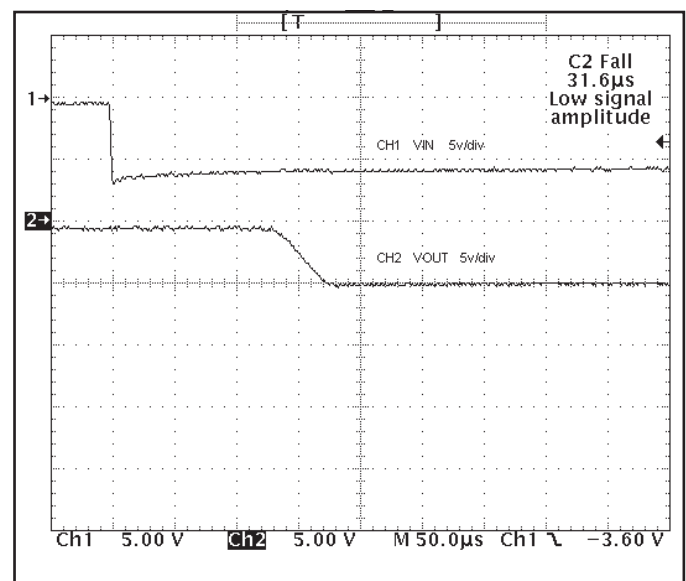

Figure 13. V_{IN} to V_{OUT} delay with CT capacitor removed.