

**INTEGRATED CIRCUITS**

# DATA SHEET



## UDA1335H

### Universal Serial Bus (USB) Audio Playback Recording Peripheral (APRP)

Preliminary specification  
File under Integrated Circuits, IC01

1998 Aug 28

# Universal Serial Bus (USB) Audio Playback Recording Peripheral (APRP)

UDA1335H



## FEATURES

### General

- USB stereo audio record and playback system with 20 bits analog-to-digital conversion (with 5 to 55 kHz sample frequency range) and adaptive 20 bits digital-to-analog conversion (with 5 to 55 kHz sample frequency range) with integrated filtering
- USB-compliant audio/HID device
- Supports 12 Mbits/s 'full speed' serial data transmission
- Fully automatic 'Plug-and-Play' operation
- Supports multiple audio data formats (8, 16 and 24 bits)
- 5.0 and 3.3 V power supply
- Low power consumption
- Efficient power management
- On-chip master clock oscillators, only an external crystal is required
- High linearity
- Wide dynamic range
- Superior signal-to-noise ratio
- Low total harmonic distortion
- Supports headphone and line output
- Partly programmable USB descriptors and configuration via the I<sup>2</sup>C-bus.

### Sound processing (for digital-to analog conversion)

- Separate digital volume control for left and right channel
- Soft mute
- Digital bass and treble tone control
- External Digital Sound Processor (DSP) option possible via standard I<sup>2</sup>S-bus or Japanese digital I/O format
- Selectable clipping prevention
- Selectable Dynamic Bass Boost (DBB)
- On-chip digital de-emphasis.

### Document references

- "USB Specification"
- "USB Device Class Definition for Audio Devices"
- "Device Class Definition for Human Interface Devices (HID)"
- "USB HID Usage Table"
- "USB Common Class Specification".

### GENERAL DESCRIPTION

The UDA1335H is a stereo CMOS codec incorporating bitstream converters designed for implementation in USB-compliant audio peripherals and multimedia audio applications. The UDA1335H is an adaptive asynchronous sink USB audio device with a continuous sampling frequency range from 5 to 55 kHz. It contains a USB interface, an embedded microcontroller, an Analog-to-Digital Interface (ADIF) and an Asynchronous Digital-to-Analog Converter (ADAC).

The USB interface is the interface between the USB, the ADIF, the ADAC and the microcontroller. The USB interface consists of an analog front-end and a USB processor. The analog front-end transforms the differential USB data into a digital data stream. The USB processor buffers the incoming and outgoing data from the analog front-end and handles all low-level USB protocols.

The USB processor selects the relevant data from the universal serial bus, performs an extensive error detection and separates control information (input and output) and audio information (input and output). The control information is made accessible to the microcontroller. The audio information received from the PC becomes available at the digital I/O output or is fed directly to the ADAC. The audio information to be transmitted to the PC is delivered by the ADIF or by the digital I<sup>2</sup>S-bus interface.

The microcontroller handles the high-level USB protocols, translates the incoming control requests and manages the user interface via general purpose pins and an I<sup>2</sup>C-bus.

## Universal Serial Bus (USB) Audio Playback Recording Peripheral (APRP)

UDA1335H

The firmware for the microcontroller must be located in an external (E)PROM.

The ADAC enables the wide and continuous range of input sampling frequencies. By means of a Sample Frequency Generator (SFG), the ADAC is able to reconstruct the average sample frequency from the incoming audio samples. The ADAC also performs the sound processing. The ADAC consists of a FIFO, a unique audio feature processing DSP, the SFG, digital upsampling filters, a variable hold register, a Noise Shaper (NS) and a Filter Stream DAC (FSDAC) with integrated filter and line output drivers. The audio information is applied to the ADAC via the USB processor or via the digital I/O input.

The ADIF consists of an Programmable Gain Amplifier (PGA), an Analog-to-Digital Converter (ADC) and a Decimator Filter (DF). An Analog Phase Lock Loop (APLL) or oscillator is used for clocking the ADIF. The clock frequency for the ADIF can be controlled via the microcontroller. Several clock frequencies are possible for sampling the analog input signal at different sampling rates.

Via the digital I/O-bus, an external DSP can be used for adding extra sound processing features for the audio received from the PC.

The UDA1335H supports the digital I/O and the I<sup>2</sup>S-bus interface, with standard I<sup>2</sup>S-bus data input format and the LSB justified serial data input format with word lengths of 16, 18 and 20 bits.

The wide dynamic range of the bitstream conversion technique used in the UDA1335H guarantees a high audio sound quality.

### APPLICATIONS

- USB monitors
- USB speakers
- USB headsets
- USB telephone/answering machines
- USB links in consumer audio devices.

### ORDERING INFORMATION

TYPE NUMBER	PACKAGE		
	NAME	DESCRIPTION	VERSION
UDA1335H	QFP64	plastic quad flat package; 64 leads (lead length 1.95 mm); body 14 × 20 × 2.8 mm	SOT319-2

# Universal Serial Bus (USB) Audio Playback Recording Peripheral (APRP)

UDA1335H

**QUICK REFERENCE DATA**

SYMBOL	PARAMETER	CONDITIONS	MIN.	TYP.	MAX.	UNIT
<b>Supplies</b>						
$V_{DDE}$	supply voltage periphery		4.75	5.0	5.25	V
$V_{DDI}$	supply voltage core		3.0	3.3	3.6	V
$I_{DD(tot)}$	total supply current		–	60	tbf	mA
$I_{DD(tot)(ps)}$	total supply current in power-saving mode	note 1	–	360	–	$\mu$ A
<b>Dynamic performance DAC</b>						
(THD + N)/S	total harmonic distortion plus noise-to-signal ratio	$f_s = 44.1$ kHz; $R_L = 5$ k $\Omega$ $f_i = 1$ kHz (0 dB)  $f_i = 1$ kHz (–60 dB)	– – – –	–90 0.0032 –30 3.2	–80 0.01 –20 10	dB % dB %
S/N	signal-to-noise ratio at bipolar zero	A-weighted at code 0000H	90	95	–	dBA
$V_{o(FS)(rms)}$	full-scale output voltage (RMS value)	$V_{DD} = 3.3$ V	–	0.66	–	V
<b>Dynamic performance PGA and ADC</b>						
(THD + N)/S	total harmonic distortion plus noise-to-signal ratio	$f_s = 44.1$ kHz; PGA gain = 0 dB $f_i = 1$ kHz; (0 dB); $V_i = 1.0$ V (RMS)  $f_i = 1$ kHz (–60 dB)	– – – –	–85 0.0056 –30 3.2	–80 0.01 –20 10.0	dB % dB %
S/N	signal-to-noise ratio	$V_i = 0.0$ V	90	95	–	dBA
<b>General characteristics</b>						
$f_{i(s)}$	audio input sample frequency		5	–	55	kHz
$T_{amb}$	operating ambient temperature		0	25	70	$^{\circ}$ C

**Note**

1. Exclusive the  $I_{DDE}$  current which depends on the components connected to the I/O pins.

# Universal Serial Bus (USB) Audio Playback Recording Peripheral (APRP)

UDA1335H

## BLOCK DIAGRAM

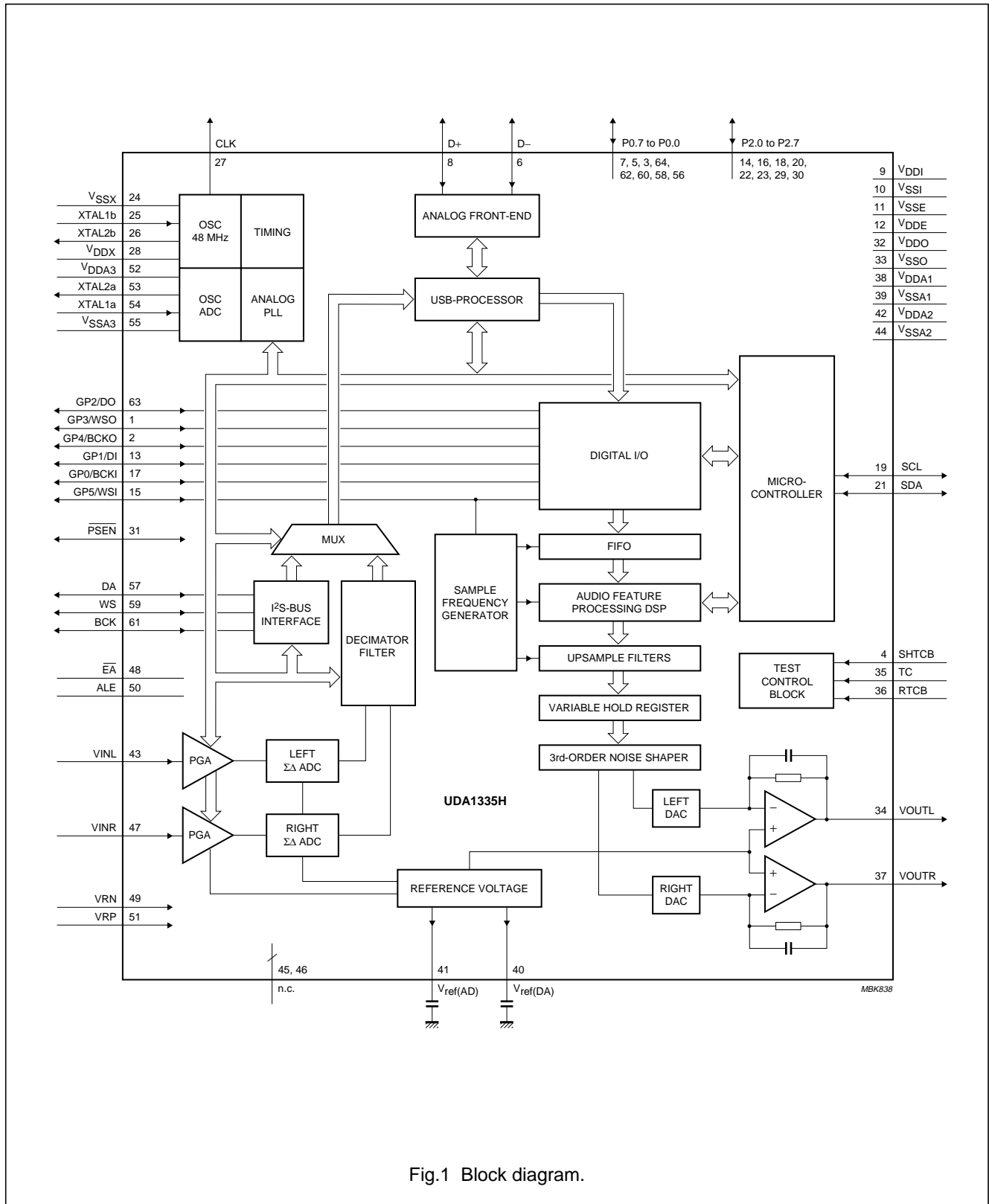

Fig.1 Block diagram.

# Universal Serial Bus (USB) Audio Playback Recording Peripheral (APRP)

UDA1335H

**PINNING**

SYMBOL	PIN QFP64	I/O	DESCRIPTION
GP3/WSO	1	I/O	general purpose pin 3 or word select output
GP4/BCKO	2	I/O	general purpose pin 4 or bit clock output
P0.5	3	I/O	port 0.5 of the microcontroller
SHTCB	4	I	shift clock of the test control block (active HIGH)
P0.6	5	I/O	port 0.6 of the microcontroller
D-	6	I/O	negative data line of the differential data bus, conforms to the USB standard
P0.7	7	I/O	port 0.7 of the microcontroller
D+	8	I/O	positive data line of the differential data bus, conforms to the USB standard
V <sub>DDI</sub>	9	-	digital supply voltage for core
V <sub>SSI</sub>	10	-	digital ground for core
V <sub>SSE</sub>	11	-	digital ground for I/O pads
V <sub>DDE</sub>	12	-	digital supply voltage for I/O pads
GP1/DI	13	I/O	general purpose pin 1 or data input
P2.0	14	I/O	port 2.0 of the microcontroller
GP5/WSI	15	I/O	general purpose pin 5 or word select input
P2.1	16	I/O	port 2.1 of the microcontroller
GP0/BCKI	17	I/O	general purpose pin 0 or bit clock input
P2.2	18	I/O	port 2.2 of the microcontroller
SCL	19	I/O	serial clock line I <sup>2</sup> C-bus
P2.3	20	I/O	port 2.3 of the microcontroller
SDA	21	I/O	serial data line I <sup>2</sup> C-bus
P2.4	22	I/O	port 2.4 of the microcontroller
P2.5	23	I/O	port 2.5 of the microcontroller
V <sub>SSX</sub>	24	-	crystal oscillator ground (48 MHz)
XTAL1b	25	I	crystal input (analog; 48 MHz)
XTAL2b	26	O	crystal output (analog; 48 MHz)
CLK	27	O	48 MHz clock output signal
V <sub>DDX</sub>	28	-	supply crystal oscillator (48 MHz)
P2.6	29	I/O	port 2.6 of the microcontroller
P2.7	30	I/O	port 2.7 of the microcontroller
PSEN	31	I/O	program store enable (active LOW)
V <sub>DDO</sub>	32	-	supply voltage for operational amplifier
V <sub>SSO</sub>	33	-	operational amplifier ground
VOU <sub>TL</sub>	34	O	voltage output left channel
TC	35	I	test control input (active HIGH)
RTCB	36	I	asynchronous reset input of the test control block (active HIGH)
VOU <sub>TR</sub>	37	O	voltage output right channel
V <sub>DDA1</sub>	38	-	analog supply voltage 1
V <sub>SSA1</sub>	39	-	analog ground 1

## Universal Serial Bus (USB) Audio Playback Recording Peripheral (APRP)

UDA1335H

SYMBOL	PIN QFP64	I/O	DESCRIPTION
$V_{ref(DA)}$	40	O	reference voltage output DAC
$V_{ref(AD)}$	41	O	reference voltage output ADC
$V_{DDA2}$	42	–	analog supply voltage 2
VINL	43	I	input signal left channel PGA
$V_{SSA2}$	44	–	analog ground 2
n.c.	45	–	not connected
n.c.	46	–	not connected
VINR	47	I	input signal right channel PGA
$\overline{EA}$	48	–	external access (active LOW)
VRN	49	I	negative reference input voltage ADC
ALE	50	–	address latch enable (active HIGH)
VRP	51	I	positive reference input voltage ADC
$V_{DDA3}$	52	–	supply voltage for crystal oscillator and analog PLL
XTAL2a	53	O	crystal output (analog; ADC)
XTAL1a	54	I	crystal input (analog; ADC)
$V_{SSA3}$	55	–	crystal oscillator and analog PLL ground
P0.0	56	I/O	port 0.0 of the microcontroller
DA	57	I	data Input (digital)
P0.1	58	I/O	port 0.1 of the microcontroller
WS	59	I	word select input (digital)
P0.2	60	I/O	port 0.2 of the microcontroller
BCK	61	I	bit clock input (digital)
P0.3	62	I/O	port 0.3 of the microcontroller
GP2/DO	63	I/O	general purpose pin 2 or data output
P0.4	64	I/O	port 0.4 of the microcontroller

Universal Serial Bus (USB) Audio  
Playback Recording Peripheral (APRP)

UDA1335H

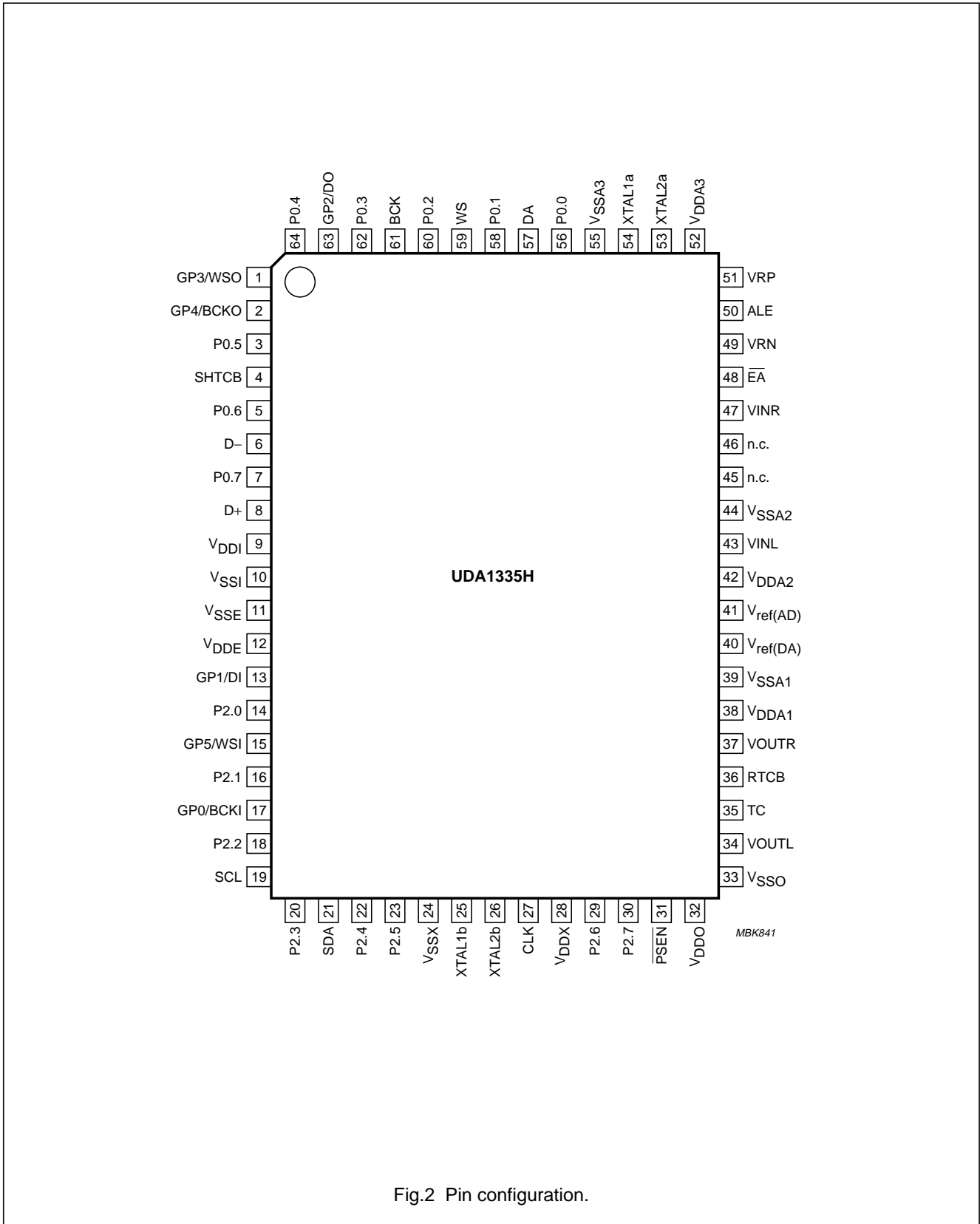

Fig.2 Pin configuration.



# Universal Serial Bus (USB) Audio Playback Recording Peripheral (APRP)

UDA1335H

## FUNCTIONAL DESCRIPTION

### The Universal Serial Bus (USB)

Data and power is transferred via the USB over a 4-wire cable. The signalling occurs over two wires and point-to-point segments. The signals on each segment are differentially driven into a cable of 90  $\Omega$  intrinsic impedance. The differential receiver features input sensitivity of at least 200 mV and sufficient common mode rejection.

### The analog front-end

The analog front-end is an on-chip generic USB transceiver. It is designed to allow voltage levels up to  $V_{DD}$  from standard or programmable logic to interface with the physical layer of the USB. It is capable of receiving and transmitting serial data at full speed (12 Mbits/s).

### The USB processor

The USB processor forms the interface between the analog front-end, the ADIF, the ADAC and the microcontroller. The USB processor consists of:

- The Philips Serial Interface Engine (PSIE)
- The Memory Management Unit (MMU)
- The Audio Sample Redistribution (ASR) module.

### The Philips Serial Interface Engine and Memory Management Unit (PSIE/MMU)

The PSIE/MMU translates the electrical USB signals into bytes and signals. Depending upon the USB device address and the USB endpoint address, the USB data is directed to the correct endpoint buffer on the PSIE/MMU interface. The data transfer could be of bulk, isochronous, control or interrupt type. The USB device address is configured during the enumeration process.

The UDA1335H has four endpoints. These are:

- Control endpoint 0
- Status interrupt endpoint
- Isochronous data sink endpoint
- Isochronous data source endpoint.

The amount of bytes/packet on the control endpoint is limited by the PSIE/MMU hardware to 8 bytes/packet.

The PSIE is the digital front-end of the USB processor. This module recovers the 12 MHz USB clock, detects the USB sync word and handles all low-level USB protocols and error checking.

The MMU is the digital back-end of the USB processor. It handles the temporary data storage of all USB packets that are received or sent over the bus. Three types of packets are defined on the USB. These are:

- Token packets
- Data packets
- Handshake packets.

The token packet contains information about the destination of the data packet. The audio data is transferred via an isochronous data sink endpoint or source endpoint and, consequently, no handshaking mechanism is used. The MMU also generates a 1 kHz clock that is locked to the USB Start Of Frame (SOF) token.

### The Audio Sample Redistribution (ASR)

The ASR reads the audio samples from the MMU and distributes these samples equidistant over a 1 ms frame period. The distributed audio samples are translated by the digital I/O module to standard I<sup>2</sup>S-bus format or Japanese digital I/O format. The ASR generates the bit clock and the word select signal of the digital I/O. The digital I/O formats the received audio samples to one of the four specified serial digital audio formats (I<sup>2</sup>S-bus, 16, 18 or 20 bits LSB-justified).

### The microcontroller

The microcontroller receives the control information selected from the USB by the USB processor. It handles the high-level USB protocols and the user interfaces.

The major task of the software process, that is mapped upon the microcontroller, is to control the different modules of the UDA1335H in such a way that it behaves as a USB device.

Therefore the microcontroller:

- Interprets the USB requests and maps them upon the UDA1335H application
- Controls the internal operation of the UDA1335H, the digital I/O pins and the GP I/O pins
- Communicates with the external world (external controller, EEPROM) using the I<sup>2</sup>C-bus facility and the GP I/O pins.

The microcontroller does not handle the audio stream. The UDA1335H will be delivered with USB compliant firmware. The firmware must be located in an external (E)PROM.

## Universal Serial Bus (USB) Audio Playback Recording Peripheral (APRP)

UDA1335H

### The Analog-to-Digital Interface (ADIF)

The ADIF is used for sampling an analog input signal from a microphone or line input and sending the audio samples to the USB interface. The ADIF consists of a stereo Programmable Gain Amplifier (PGA), a stereo Analog-to-Digital Converter (ADC) and Decimation Filters (DFs). The sample frequency of the ADC is determined by the ADC clock (see Section "The timing of the analog-to-digital interface"). The user can also select a digital serial input instead of an analog input. In this event the sample frequency is determined by the continuous WS clock with a range between 5 to 55 kHz. Digital serial input is possible with four formats (I<sup>2</sup>S-bus, 16, 18 or 20 bits LSB-justified).

### The Programmable Gain Amplifier circuit (PGA)

This circuit can be used for a microphone or line input. The input audio signals can be amplified by 7 different gains. The preferred gain is selected during start-up of the device (configuration map).

The gain settings are given in Table 1.

**Table 1** The selectable gains of the PGA

SETTING	GAIN	UNIT
000	-3	dB
001	0	dB
010	3	dB
011	9	dB
100	15	dB
101	21	dB
11X	27	dB

### The Analog-to-Digital Converter (ADC)

The stereo ADC of the UDA1335H consists of two 3rd-order Sigma-Delta modulators. They have a modified Ritchie-coder architecture in a differential switched capacitor implementation. The oversampling ratio is 128. Both ADCs can be switched off in power saving mode (left and right separate). The ADC clock is generated by the analog PLL or the ADC oscillator.

### The Decimation Filter (DF)

The decimator filter converts the audio data from  $128f_s$  down to  $1f_s$  with a word width of 8, 16 or 24 bits. This data will be transmitted over the USB as mono or stereo in 1, 2 or 3 bytes/sample. The decimator filters are clocked by the ADC clock.

### The timing of the analog-to-digital interface

The clock source of the ADIF is the analog PLL or the ADC oscillator. The preferred clock source can be selected during start-up of the device (configuration map). The ADC clock used for the ADC and decimation filters is obtained by dividing the clock signal coming from the analog PLL or from the ADC oscillator by a factor Q.

Using the analog PLL the user can select 3 clock frequencies via the microcontroller.

By connecting the appropriate crystal the user can choose any clock signal between 8.192 and 14.08 MHz via the ADC oscillator.

**Table 2** The analog PLL clock output frequencies

F CODE	APLL CLOCK FREQUENCY (MHz)
00	11.2896
01	8.1920
10	12.2880
11	11.2896

The dividing factor Q can be selected via the microcontroller. With this dividing factor Q the user can select a range of ADC clock signals allowing several different sample frequencies (see Table 3).

## Universal Serial Bus (USB) Audio Playback Recording Peripheral (APRP)

UDA1335H

**Table 3** ADC clock frequencies and sample frequencies based upon using the APLL as a clock source (analog input topology 1), see note 1.

APLL CLOCK FREQUENCY (MHz)	DIVIDE FACTOR Q	ADC CLOCK FREQUENCY (MHz)	SAMPLE FREQUENCY (kHz)
8.1920	1	4.096	32
	2	2.048	16
	4	1.024	8
	8	0.512 (not supported)	4 (not supported)
11.2896	1	5.6448	44.1
	2	2.8224	22.05
	4	1.4112	11.025
	8	0.7056	5.5125
12.2880	1	6.144	48
	2	3.072	24
	4	1.536	12
	8	0.768	6

### Note

- By using the APLL as a clock source 12 sample frequencies will be reported to the USB host.

**Table 4** ADC clock frequencies and sample frequencies based upon using the OSCAD as a clock source (analog input topology 4), see note 1

OSCAD CLOCK FREQUENCY (MHz)	DIVIDE FACTOR Q	ADC CLOCK FREQUENCY (MHz)	SAMPLE FREQUENCY (kHz)
$f_{osc}^{(2)}$	$Q^{(3)}$	$f_{osc}/(2Q)$	$f_{osc}/(256Q)^{(4)}$

### Notes

- By using the OSCAD as a clock source, the sample frequency and the Q dividing factor must be filled in the configuration map. Only this one sample frequency will be reported to the USB host.
- The oscillator frequency (and therefore the crystal) of OSCAD must be between 8.192 and 14.08 MHz.
- The Q factor can be 1, 2, 4 or 8.
- Sample frequencies below 5 kHz and above 55 kHz are not supported.

## Universal Serial Bus (USB) Audio Playback Recording Peripheral (APRP)

UDA1335H

### The Asynchronous Digital-to-Analog Converter (ADAC)

The ADAC receives USB audio information from the USB processor or from the digital I/O-bus. The ADAC is able to reconstruct the sample clock from the rate at which the audio samples arrive and handles the audio sound processing. After the processing, the audio signal is upsampled, noise-shaped and converted to analog output voltages capable of driving a line output. The ADAC consists of:

- A Sample Frequency Generator (SFG)
- FIFO registers
- An audio feature processing DSP
- Two digital upsampling filters and a variable hold register
- A digital Noise Shaper (NS)
- A Filter Stream DAC (FSDAC) with integrated filter and line output drivers.

### The Sample Frequency Generator (SFG)

The SFG controls the timing signals for the asynchronous digital-to-analog conversion. By means of a digital PLL, the SFG automatically recovers the applied sampling frequency and generates the accurate timing signals for the audio feature processing DSP and the upsampling filters.

### First-In First-Out (FIFO) registers

The FIFO registers are used to store the audio samples temporarily coming from the USB processor or from the digital I/O input. The use of a FIFO (in conjunction with the SFG) is necessary to remove all jitter present on the incoming audio signal.

### The audio feature processing DSP

A DSP processes the sound features. The control and mapping of the sound features is explained in Section "Controlling the USB APRP". Depending on the sampling rate ( $f_s$ ) the DSP knows four frequency domains in which the treble and bass are regulated. The domain is chosen automatically.

**Table 5** Frequency domains for audio processing by the DSP

DOMAIN	SAMPLE FREQUENCY (kHz)
1	5 to 12
2	12 to 25
3	25 to 40
4	40 to 55

### The upsampling filters and variable hold function

After the audio feature processing DSP two upsampling filters and a variable hold function increase the oversampling rate to  $128f_s$ .

### The noise shaper

A 3rd-order noise shaper converts the oversampled data to a noise-shaped bitstream for the FSDAC. The in-band quantization noise is shifted to frequencies well above the audio band.

### The Filter Stream DAC (FSDAC)

The FSDAC is a semi-digital reconstruction filter that converts the 1-bit data stream of the noise shaper to an analog output voltage. The filter coefficients are implemented as current sources and are summed at virtual ground of the output operational amplifier. In this way very high signal-to-noise performance and low clock jitter sensitivity is achieved. A post filter is not needed because of the inherent filter function of the DAC. On-board amplifiers convert the FSDAC output current to an output voltage signal capable of driving a line output.

### USB Audio Playback Recording Peripheral (APRP) descriptors

In a typical USB environment the PC has to know which kind of devices are connected. For this purpose each device contains a number of USB descriptors. These descriptors describe, from different points of view (USB configuration, USB interface and USB endpoint), the capabilities of a device. Each of them can be requested by the host. The collection of descriptors is denoted as a descriptor map. This descriptor map will be reported to the USB host during enumeration and on request.

The USB descriptors and their most important fields, in relationship to the characteristics of the UDA1335H are explained briefly below.

# Universal Serial Bus (USB) Audio Playback Recording Peripheral (APRP)

UDA1335H

## AUDIO FUNCTION TOPOLOGIES

Four audio function Input topologies and two audio function output topologies are supported by the UDA1335H. Each configuration map can select only one Input and one output topology. The descriptors and the supported requests depend on the selected topologies in the active configuration map. Figures 3 and 4 illustrate the different audio Input and output topologies.

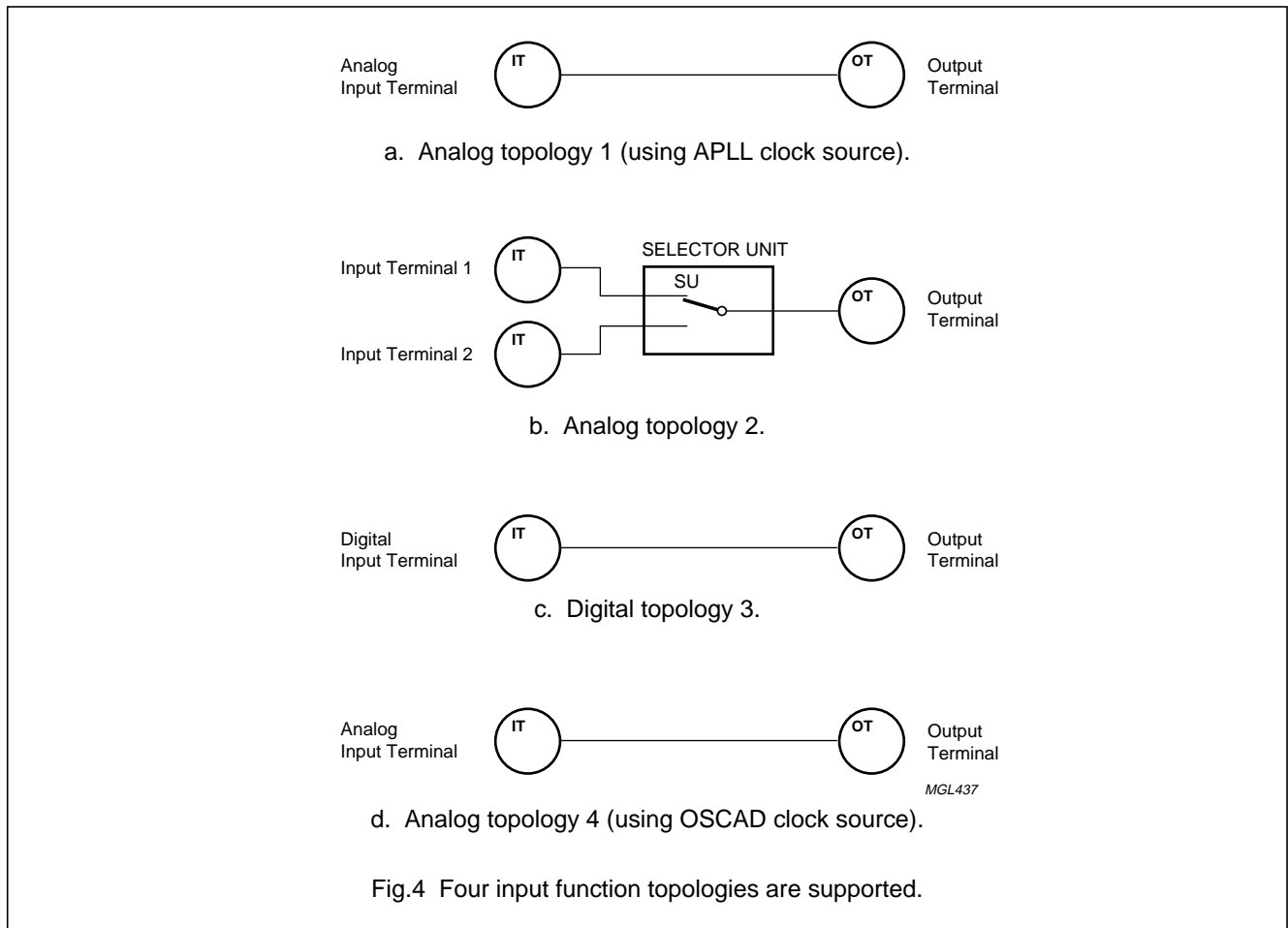
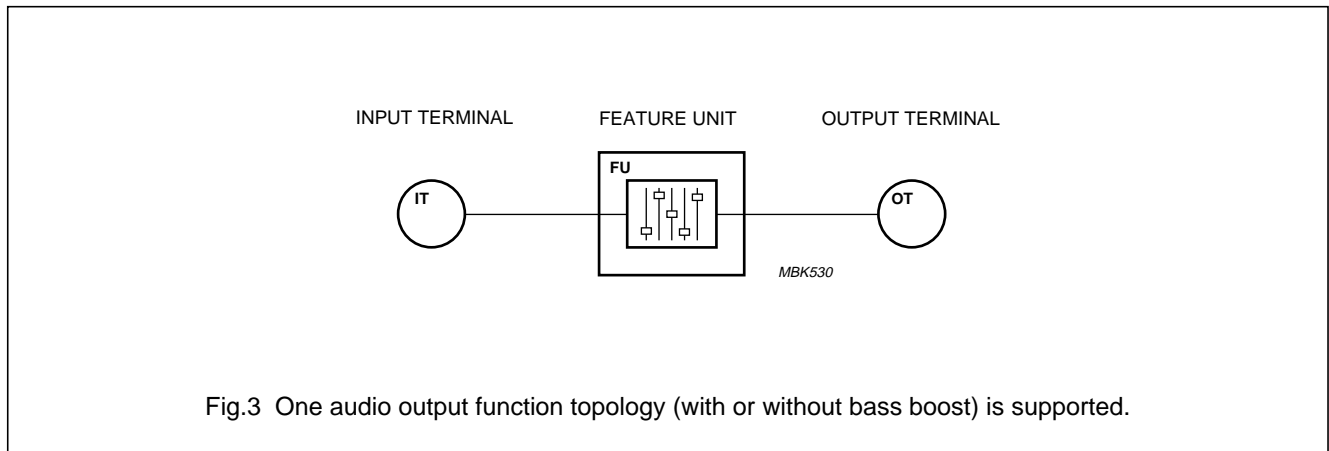

## Universal Serial Bus (USB) Audio Playback Recording Peripheral (APRP)

UDA1335H

### GENERAL DESCRIPTORS

The UDA1335H supports one configuration containing a control interface, two audio interfaces and a HID interface. The descriptor map that describes this configuration is partly fixed and partly programmable.

The programmable part can be retrieved from one of four configuration maps located in the firmware or from an I<sup>2</sup>C-bus EEPROM. At start-up time one of four internal configuration maps can be selected depending on the logical combination of GP3 and GP4. It is possible to overwrite this configuration map with a configuration map loaded from an I<sup>2</sup>C-bus EEPROM.

### AUDIO DEVICE CLASS SPECIFIC DESCRIPTORS

The audio device class is partly specified with standard descriptors and partly with specific audio device class descriptors. The standard descriptors specify the number and the type of the interface or endpoint. The UDA1335H supports 7 different audio modes:

- 8-bit PCM mono or stereo audio data
- 16-bit PCM mono or stereo audio data
- 24-bit PCM mono or stereo audio data
- Zero bandwidth mode.

Each mode is defined as an alternate setting of the audio interface, selectable with the standard audio streaming interface descriptor **bAlternateSetting** field.

The seven alternate settings are described in more detail by the specific audio device class descriptors.

The UDA1335H supports the input terminal, output terminal and the feature unit descriptors.

The input and output terminals are not controllable via the USB. The feature unit provides the basic manipulation of the incoming logical channels.

The supported sound features are:

- Volume control
- Mute control
- Treble control
- Bass control
- Bass Boost control.

The maximum number of audio data samples within a USB packet arriving on the isochronous sink endpoint is restricted by the buffer capacity of this isochronous endpoint. The maximum buffer capacity is 336 bytes/ms.

The input terminals can be defined by means of **wTerminalType**.

### THE STANDARD AUDIO STREAMING INTERFACE DESCRIPTOR FOR THE ISOCRONOUS DATA SINK ENDPOINT

In this section the descriptors are given for interface 1 which is used for receiving isochronous audio data from the host.

Although in this specific UDA1335H application no endpoint control properties can be used on the isochronous adaptive sink endpoint, the descriptors are still necessary to inform the host about the definition of this endpoint: isochronous, adaptive, sink, continuous sampling frequency (at input side of this endpoint) with a lower boundary of 5 kHz and an upper boundary of 55 kHz.

The audio class specific descriptors can be requested with the 'Get Descriptor: configuration request', which returns all the descriptors, except the device descriptor.

For each alternate setting with audio, a maximum bandwidth is claimed as indicated in the standard isochronous audio data endpoint descriptor **wMaxPacketSize** field. To allow a small overshoot in the number of audio samples per packet, the top sample frequency of 55 kHz is taken in the calculation of the bandwidth for each alternate setting. For each alternate setting, with its own isochronous audio data endpoint descriptor, **wMaxPacketSize** field is then defined as described in Table 6.

**Table 6** Audio bandwidth at each audio mode

ALTERNATE SETTING	AUDIO MODE	wMaxPacketSize (HEX)
1	8-bit PCM, mono	3800
2	8-bit PCM, stereo	7000
3	16-bit PCM, mono	7000
4	16-bit PCM, stereo	E000
5	24-bit PCM, mono	A800
6	24-bit PCM, stereo	5001

### THE STANDARD AUDIO STREAMING INTERFACE DESCRIPTOR FOR THE ISOCRONOUS DATA SOURCE ENDPOINT

Interface 2 is used for sending isochronous audio data to the host. It has the same alternate settings as interface 1.

## Universal Serial Bus (USB) Audio Playback Recording Peripheral (APRP)

UDA1335H

### HUMAN INTERFACE DEVICE SPECIFIC DESCRIPTORS

The inputs defined on the UDA1335H are transmitted via the USB to the host according to the HID class. The host responds with the appropriate settings via the audio device class for the audio related parts or via the HID class for the HID related inputs and outputs of the UDA1335H.

A HID descriptor is necessary to inform the host about the conception of the user interface. The host communicates via the HID device driver using either the control pipe or the interrupt pipe. The UDA1335H is using USB endpoint 0 (control pipe) to respond to the HID specific 'Get/Set Report request' to receive or transmit data from or to the UDA1335H. The UDA1335H uses the status interrupt endpoint as interrupt pipe for polling asynchronous data.

The UDA1335H is a high-speed device. The maximum transaction size is 64 bytes per USB frame and the polling rate is defined at a maximum of every 1 ms.

The host requests the configuration descriptor which includes the standard interface descriptor, the HID endpoint descriptor and the HID descriptor. The HID device driver of the host then requests the report descriptor.

Report descriptors are composed of pieces of information about the device. Each piece of information is called an item. All items have a 1-byte prefix that contains the item tag, type and size. In the UDA1335H only the short item basic type is used.

The hosts HID device driver will parse the report descriptor and the defined items. By examining all of these items, the HID class driver is able to determine the size and composition of data reports from the device.

The main items of the UDA1335H are input reports. Input reports are sent via the interrupt pipe (UDA1335H USB endpoint 3). Input reports can be requested by the host via the control endpoint (USB endpoint 0).

The UDA1335H supports a maximum of two push-buttons (six with I<sup>2</sup>C-bus expanders), which represent a certain feature of the UDA1335H.

If pressed by the user the pushbutton will go to its 'ON' state, if not pressed the push-button will go back to its 'OFF' state.

For more information about the input functions of the UDA1335H see the application documentation of the device.

### Controlling the USB APRP

The sound features as defined in the "USB Device Class Definition for Audio Devices" are mapped on the UDA1335H specific feature registers by the microcontroller. These specific sound features are:

- Volume control (separate for left and right stereo channels, no master channel)
- Mute control (only master channel)
- Treble control (only master channel)
- Bass control (only master channel)
- Dynamic bass boost control (only master channel).

These specific features can be activated via the host (audio device class requests) or via the GP I/O pins (HID plus audio device class requests). The user is able to download the necessary configuration data for different applications (definition of the function of the GP pins, with or without digital I/O functionality etc.) via the configuration map. The mapping and control of the standard USB audio features and UDA1335H specific features is described below.

#### Volume control

Volume control is possible via the host or via predefined GP I/O pins. The setting of 0 dB is always referenced to the maximum available volume setting. Table 7 gives the mapping of **wVolume** value (as defined in the "USB Device Class Definition for Audio Devices") upon the actual volume setting of the USB APRP. When using the UDA1335H, the range is 0 dB down to -60 dB (in steps of 1 dB) and -∞ dB. Independant control of 'left'/'right' volume is possible.

It should be noted that **wVolume**<sub>LSB</sub> B7 to B0 are not used. Values above 0 dB are returned as 0 dB. The volume value at start-up of the device is defined in the selected configuration map.

Balance control is possible via the separate volume control option of both channels. Therefore the characteristics of the balance control are equal to the volume control characteristics.

# Universal Serial Bus (USB) Audio Playback Recording Peripheral (APRP)

UDA1335H

**Table 7** Volume control characteristics

wVOLUME (MSB)								VOLUME USB SIDE (dB)	VOLUME USB APRP (dB)
B15	B14	B13	B12	B11	B10	B9	B8		
0	0	0	0	0	0	0	0	0	0
1	1	1	1	1	1	1	1	-1	-1
1	1	1	1	1	1	1	0	-2	-2
1	1	1	1	1	1	0	1	-3	-3
1	1	1	1	1	1	0	0	-4	-4
1	1	1	1	1	0	1	1	-5	-5
1	1	1	1	1	0	1	0	-6	-6
1	1	1	1	1	0	0	1	-7	-7
1	1	1	1	1	0	0	0	-8	-8
1	1	1	1	0	1	1	1	-9	-9
1	1	1	1	0	1	1	0	-10	-10
...	...	...	...	...	...	...	...	...	...
1	1	0	0	0	1	0	1	-59	-59
1	1	0	0	0	1	0	0	-60	-60
1	1	0	0	0	0	1	1	-61	-∞
1	1	0	0	0	0	1	0	-62	-∞
...	...	...	...	...	...	...	...	...	...
1	0	0	0	0	0	0	0	-∞	-∞



## Universal Serial Bus (USB) Audio Playback Recording Peripheral (APRP)

UDA1335H

### Mute control

Mute is one of the sound features as defined in the “*USB Device Class Definition for Audio Devices*”. The mute control request data **bMute** controls the position of the mute switch. The position can be either on or off. When **bMute** is true the feature unit is muted. When **bMute** is false the feature unit is not muted.

When the mute is active for the master channel, the value of the sample is decreased smoothly to zero following a raised cosine curve. There are 32 coefficients used to step down the value of the data, each one being used 32 times before stepping to the next. This amounts to a mute transition of 23 ms at  $f_s = 44.1$  kHz. When the mute is released, the samples are returned to the full level again following a raised cosine curve with the same coefficients being used in reversed order.

The mute, on the master channel is synchronized to the sample clock, so that operation always takes place on complete samples.

A mute can be given via the host or by pressing a predefined GP pin.

### Treble control

The treble control is available for the master channel of the UDA1335H. The treble range is from 0 to 6 dB in steps of 2 dB. It should be noted that the negative treble values as defined in the “*USB Device Class Definition for Audio Devices*” are not supported by the UDA1335H; values below 0 dB are returned as 0 dB. The corner frequency is 1500 Hz. Table 8 gives the mapping of the **bTreble** value upon the actual treble setting of the USB APRP.

**Table 8** Treble control characteristics

bTREBLE								TREBLE USB HOST (dB)	TREBLE USB APRP (dB)
B7	B6	B5	B4	B3	B2	B1	B0		
0	0	0	0	0	0	0	0	0.00	0
0	0	0	0	0	0	0	1	0.25	
0	0	0	0	0	0	1	0	0.50	
0	0	0	0	0	0	1	1	0.75	
0	0	0	0	0	1	0	0	1.00	
0	0	0	0	0	1	0	1	1.25	2
0	0	0	0	0	1	1	0	1.50	
0	0	0	0	0	1	1	1	1.75	
0	0	0	0	1	0	0	0	2.00	
0	0	0	0	1	0	0	1	2.25	
0	0	0	0	1	0	1	0	2.50	
0	0	0	0	1	0	1	1	2.75	
0	0	0	0	1	1	0	0	3.00	
0	0	0	0	1	1	0	1	3.25	4
								...	
0	0	0	1	0	1	0	1	5.25	6
								...	
0	0	0	1	1	1	0	1	7.25	6
								...	
0	0	1	0	0	1	0	1	9.25	6
								...	
0	1	1	1	1	1	1	1	31.75	6

# Universal Serial Bus (USB) Audio Playback Recording Peripheral (APRP)

UDA1335H

## Bass control

The bass control is available for the master channel of the UDA1335H. The bass range is from 0 to approximately 24 dB in steps of 2 dB. It should be noted that the negative bass values as defined in the “USB Device Class Definition for Audio Devices” are not supported by the UDA1335H; values below 0 dB are returned as 0 dB. The corner frequency is 75 Hz. Table 9 gives the mapping of the **bBASS** value upon the actual bass setting of the USB APRP.

**Table 9** Bass control characteristics

bBASS								BASS USB HOST (dB)	BASS USB APRP (dB)
B7	B6	B5	B4	B3	B2	B1	B0		
0	0	0	0	0	0	0	0	0.00	0
0	0	0	0	0	0	0	1	0.25	
0	0	0	0	0	0	1	0	0.50	
0	0	0	0	0	0	1	1	0.75	
0	0	0	0	0	1	0	0	1.00	1.7
0	0	0	0	0	1	0	1	1.25	
0	0	0	0	0	1	1	0	1.50	
0	0	0	0	0	1	1	1	1.75	
0	0	0	0	1	0	0	0	2.00	
0	0	0	0	1	0	0	1	2.25	
0	0	0	0	1	0	1	0	2.50	
0	0	0	0	1	0	1	1	2.75	
0	0	0	0	1	1	0	0	3.00	
0	0	0	0	1	1	0	1	3.25	
								...	3.6
0	0	0	1	0	1	0	1	5.25	
								...	5.4
0	0	0	1	1	1	0	1	7.25	
								...	7.4
0	0	1	0	0	1	0	1	9.25	
								...	9.4
0	0	1	0	1	1	0	1	11.25	
								...	11.3
0	0	1	1	0	1	0	1	13.25	
								...	13.3
0	0	1	1	1	1	0	1	15.25	
								...	15.2
0	1	0	0	0	1	0	1	17.25	
								...	17.3
0	1	0	0	1	1	0	1	19.25	
								...	19.2
0	0	1	1	1	0	1	1	21.25	
								...	21.2
								...	

# Universal Serial Bus (USB) Audio Playback Recording Peripheral (APRP)

UDA1335H

bBASS								BASS USB HOST (dB)	BASS USB APRP (dB)
B7	B6	B5	B4	B3	B2	B1	B0		
0	1	0	1	0	1	0	1	23.25	23.2
								...	
0	1	1	0	0	1	0	1	25.25	23.2
								...	
0	1	1	0	1	1	0	1	27.25	23.2
								...	
0	1	1	1	0	1	0	1	29.25	23.2
								...	
0	1	1	1	1	1	0	1	31.25	23.2
								...	
0	1	1	1	1	1	1	1	31.75	23.2

## Dynamic bass boost control

Bass boost is one of the sound features as defined in the “USB Device Class Definition for Audio Devices”.

The bass boost control request data **bBassBoost** controls the position of the bass boost switch. The position can be either on or off. When **bBassBoost** is true the bass boost is activated. When **bBassBoost** is false the bass boost is off.

When clipping prevention is active, the bass is reduced to avoid clipping with high volume settings. Bass boost is selectable via the configuration map.

## Clipping prevention

When clipping prevention is ON and the sum of bass plus volume gives clipping, the bass is reduced. When clipping prevention is ON and the sum of treble plus volume gives clipping, the treble is reduced. Clipping prevention and clipping level are selectable via the configuration map. For more information about clipping prevention and the clipping level see the application documentation.

## De-emphasis

De-emphasis is one of the properties which is not supported by the USB. De-emphasis for 44.1 kHz can be predefined in the configuration map selected at start-up of the UDA1335H.

## Start-up and configuration of the UDA1335H

### START-UP OF THE UDA1335H

After power-on, an internal power-on reset signal becomes HIGH after a certain RC time ( $R = 5000 \Omega$ ,  $C = C_{ref}$ ). During 20 ms after power-on reset the UDA1335H has to initiate the internal settings. After the power-on reset the UDA1335H becomes master of the I<sup>2</sup>C-bus.

The UDA1335H tries to read the eventually connected I<sup>2</sup>C-bus EEPROM and if an dedicated EEPROM is detected, the internal descriptors are overwritten and the selected port configuration is applied. If no EEPROM is detected, the UDA1335H tries to read the logic levels of GP3 and GP4. A choice can be made from four configuration maps via these two GP pins.

### CONFIGURATION SELECTION OF THE UDA1335H VIA A DIODE MATRIX

The UDA1335H uses a configuration map to hold a number of specific configurable data on hardware, product, component and USB configuration level. At start-up, without EEPROM, the UDA1335H will scan the logic levels of GP3 and GP4. With these two GP pins it is possible to select one of the four possible configuration maps which are held in the external (E)PROM. This selection can be achieved via a diode matrix (see Fig.5).

# Universal Serial Bus (USB) Audio Playback Recording Peripheral (APRP)

## UDA1335H

After selecting an internal configuration map the user cannot change the chosen settings for the GP pins, internal configuration, descriptors etc.

The UDA1335H supports a maximum of two push-buttons (six with I<sup>2</sup>C-bus expanders), which represent a certain feature of the UDA1335H.

The UDA1335H supports a maximum of three outputs for e.g. user LEDs.

For more information about the four configuration maps located in the (E)PROM and the input and output functions of the UDA1335H see the application documentation.

firmware of the microcontroller. The layout of the configuration map is fixed, the values (except bytes 0 and 1) are user definable. If the user wants to change e.g. the manufacturer name this can be achieved via the EEPROM code.

The communication between the UDA1335H and the external I<sup>2</sup>C-bus device is based on the standard I<sup>2</sup>C-bus protocol given in the Philips specification “*The I<sup>2</sup>C-bus and how to use it (including specifications)*”, which can be ordered using the code 9398 393 40011. The I<sup>2</sup>C-bus has two lines; a clock line SCL and a serial data line SDA (see Fig.6).

### CONFIGURATION OPTIONS OF THE UDA1335H VIA AN I<sup>2</sup>C-BUS EEPROM

At start-up, the UDA1335H will address I<sup>2</sup>C-bus slave address 0 × A0H and will check the first two byte locations of the I<sup>2</sup>C-bus device with 0 × 55H and 0 × AAH. If a match occurs, the UDA1335H assumes that this I<sup>2</sup>C-bus device is an EEPROM which is dedicated to the UDA1335H. It will then read the configuration map stored in this EEPROM instead of one of four configuration maps located in the

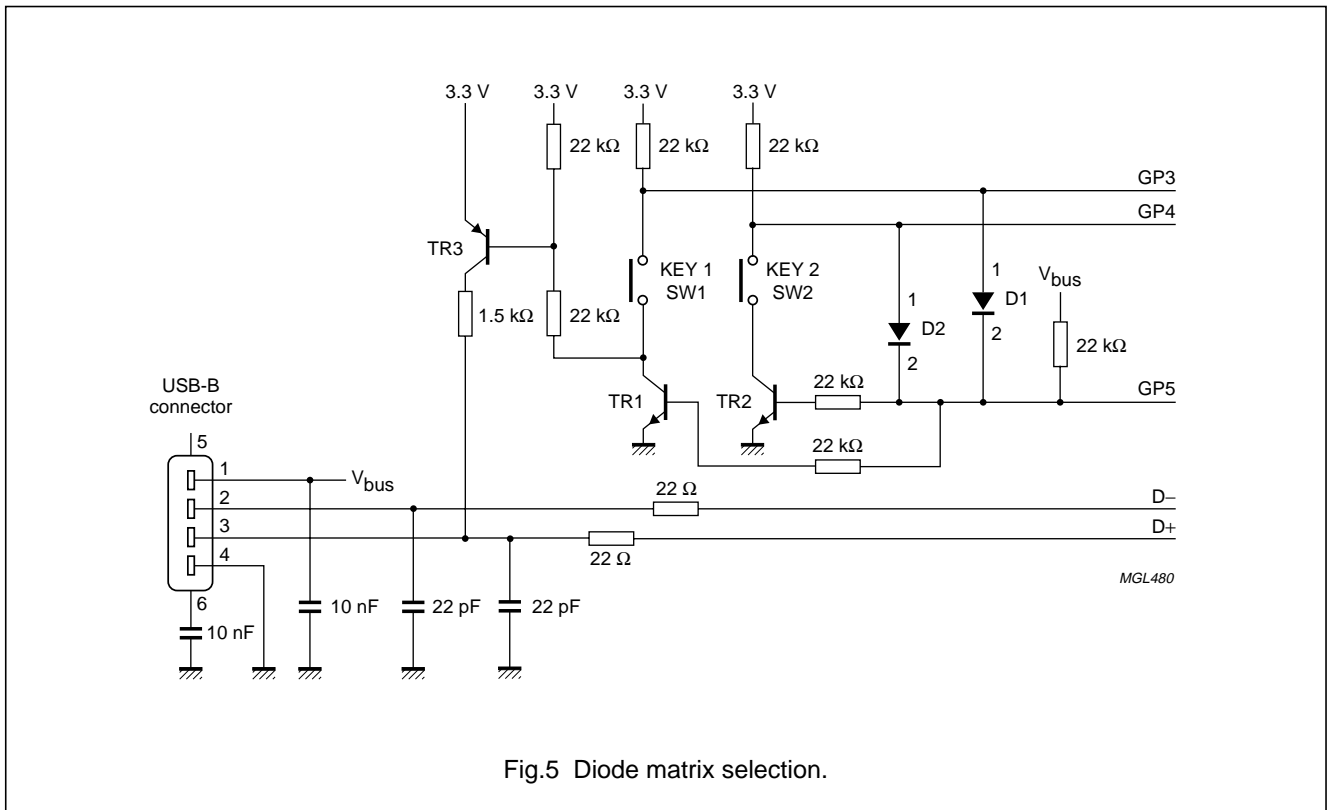

Fig.5 Diode matrix selection.

# Universal Serial Bus (USB) Audio Playback Recording Peripheral (APRP)

UDA1335H

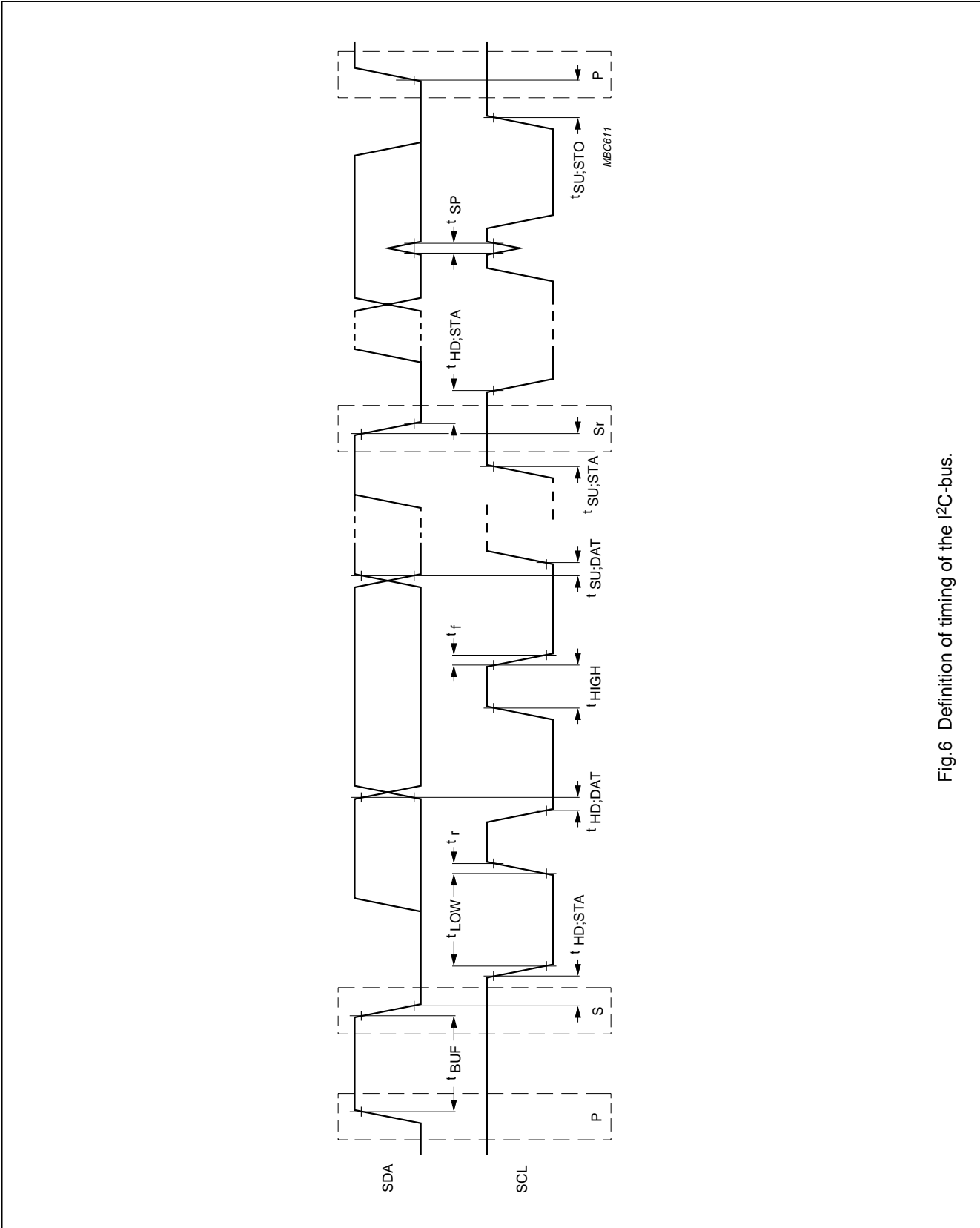

Fig.6 Definition of timing of the I2C-bus.

# Universal Serial Bus (USB) Audio Playback Recording Peripheral (APRP)

UDA1335H

**Table 10** Control options for the UDA1335H via the EEPROM configuration map; note 1

BYTE (HEX)	AFFECTS	COMMENTS	BIT	VALUE
0		recognition pattern do not change it		55H
1		recognition pattern do not change it		AAH
2	clocks control register	selection ADC clock source	7	0 = ADC clock from APLL 1 = ADC clock from OSCAD
		divide factor	6 and 5	00 = ADC clock divided-by-1
				01 = ADC clock divided-by-2
				10 = ADC clock divided-by-4
				11 = ADC clock divided-by-8
		clock ADAC	4	0
		clock 48 MHz internal	3	0
		clock recovered PSIE/MMU	2	0
		ADC clock	1	0
power on OSCAD	0	0		
3	reset generator and APLL control register			00H
4	power control register analog modules			00H
5	ASR control register	robust word clock	7	1
		serial I <sup>2</sup> S-bus output format	6 and 5	00 = I <sup>2</sup> S-bus
				01 = 16-bit LSB
				10 = 18-bit LSB
				11 = 20-bit LSB
		phase inversion (right output)	4	0 = mono phase inversal off
				1 = mono phase inversal on
		bits per sample modi	3 and 2	00 = reserved
				01 = 8-bit audio
				10 = 16-bit audio
11 = 24-bit audio				
mono or stereo operation	1	0 = mono		
		1 = stereo		
ASR register start-up mode	0	1		

## Universal Serial Bus (USB) Audio Playback Recording Peripheral (APRP)

UDA1335H

BYTE (HEX)	AFFECTS	COMMENTS	BIT	VALUE	
6	PGA control register input terminal 1 (all analog input topologies)	reserved	7	X	
		PGA internal setting (do not change it)	6	0	
		PGA gain selection right channel	5 to 3	000 = -3 dB	
				001 = 0 dB	
				010 = 3 dB	
				011 = 9 dB	
				100 = 15 dB	
				101 = 21 dB	
				110 = 27 dB	
		111 = 27 dB			
		PGA gain selection left channel	2 to 0	000 = -3 dB	
				001 = 0 dB	
				010 = 3 dB	
				011 = 9 dB	
100 = 15 dB					
101 = 21 dB					
110 = 27 dB					
111 = 27 dB					
7	PGA control register input terminal 2 (only for analog input topology 2)	reserved	7	X	
		PGA internal setting (do not change it)	6	0	
		PGA gain selection right channel	5 to 3	000 = -3 dB	
				001 = 0 dB	
				010 = 3 dB	
				011 = 9 dB	
				100 = 15 dB	
				101 = 21 dB	
				110 = 27 dB	
		111 = 27 dB			
		PGA gain selection left channel	2 to 0	000 = -3 dB	
				001 = 0 dB	
				010 = 3 dB	
				011 = 9 dB	
100 = 15 dB					
101 = 21 dB					
110 = 27 dB					
111 = 27 dB					

## Universal Serial Bus (USB) Audio Playback Recording Peripheral (APRP)

UDA1335H

BYTE (HEX)	AFFECTS	COMMENTS	BIT	VALUE
8	ADIF control register	reserved	7	X
		number of bits per audio sample to be transmitted to the host	6 and 5	00 = reserved
				01 = 8 bits audio samples
				10 = 16 bits audio samples
				11 = 24 bits audio samples
		mono/stereo selection	4	0 = mono 1 = stereo
		selection audio input channel	3	0 = digital serial audio input 1 = analog input
		selection high-pass filter of the decimation module	2	0 = high-pass filter off 1 = high-pass filter on
I <sup>2</sup> S-bus input serial input format	1 and 0			00 = I <sup>2</sup> S-bus 01 = 16-bit LSB 10 = 18-bit LSB 11 = 20-bit LSB
		selection ADAC mode register	7	0
				audio feature mode
		de-emphasis	4	
channel manipulation	3			0 = L → L, R → R 1 = L → R, R → L
		synchronous/asynchronous	2	0
mute control	1	1		
reset ADAC	0	0		
A	ADAC lock mode register	selection ADAC mode register	7	1
		digital PLL lock speed	6 and 5	00
		digital PLL lock mode	4	1
		digital PLL mode	3 and 2	00
		serial I <sup>2</sup> S-bus input format	1 and 0	00 = I <sup>2</sup> S-bus 01 = 16-bit LSB 10 = 18-bit LSB 11 = 20-bit LSB



## Universal Serial Bus (USB) Audio Playback Recording Peripheral (APRP)

UDA1335H

BYTE (HEX)	AFFECTS	COMMENTS	BIT	VALUE
B	I/O selection register	clipping	7	0 = clipping prevention OFF
				1 = clipping prevention ON
		expander	6	0 = no I <sup>2</sup> C-bus expander used
				1 = I <sup>2</sup> C-bus expander used
		selector output (GP2)	5	0 = selector state normal
				1 = selector state inverted
		mute/standby expander	4	0 = mute
				1 = standby
		mute/standby USB APRP	3	0 = mute
1 = standby				
output pin 3	2	polarity output pins		
output pin 2	1	0 = inverted logic		
output pin 1	0	1 = normal logic		
C		output pin function 1		functions are available if declared in ADC: 0 = mute LED; 1 = DBB LED
D		output pin function 2		
E		output pin function 3		
F	I <sup>2</sup> S-bus and topology selection register	output I <sup>2</sup> S-bus	7	0 = no I <sup>2</sup> S-bus used
				1 = I <sup>2</sup> S-bus used
		4-pin or 6-pin I <sup>2</sup> S-bus	6	only if I <sup>2</sup> S-bus is used: 0 = 4-pin I <sup>2</sup> S-bus 1 = 6-pin I <sup>2</sup> S-bus
		HID usage	5	0 = HID not included
				1 = HID included
		reserved	4	X
		topology selection	3	low nibble: 1 = input topology 1 2 = input topology 2 3 = input topology 3 4 = input topology 4 all other values = input topology 1
2				
1				
0				
10		rise time power amplifier, steps of 20 ms		
11		time between mute and play, steps of 1 s		
12		time between mute and standby, steps of 5 s		
13		selector preferred state (only applicable in input topology 2)		0 = terminal Input 1 or terminal input 2
14		DBB value steps of 1 dB with maximum 255 dB		0 = no DBB active
				1 to FF = DBB active
15		start-up volume value in dB		volume = -register value

## Universal Serial Bus (USB) Audio Playback Recording Peripheral (APRP)

UDA1335H

BYTE (HEX)	AFFECTS	COMMENTS	BIT	VALUE
16		maximum distortion in dB		
17	sample frequency	LSB		
18		mid		
19		MSB		
1A/1B		pointer to device descriptor		0030
1C/1D		pointer to configuration descriptor		0045
1E/1F		pointer to HID descriptor		01F0
20/21		pointer to HID report descriptor		0210
22		number of string pointers (N + 1) maximum for N is 31		
23/24		pointer to string 0		025E
25/26		pointer to string 1		0260
27/28		pointer to string 2		0290
29/2A		pointer to string 3		02D0
:		:		
23 + 2N/ 24 + 2N		pointer to string N		
30 →		device descriptor		
45 →		configuration descriptor including ADC		32
1F0 →		and HID descriptors		
210 →		wDescriptorLength		
212 →		HID report descriptor		
25E →	string 0	language string		
260 →	string 1	manufacturer string		
290 →	string 2	product string		
2D0 →	string 3	serial number <sup>(2)</sup>		

### Notes

1. An extensive description of the USB control options is available in the *"USB Device Class Definition for Audio Devices"*.
2. The serial number is only supported in the external configuration map and not in the four internal configuration maps.

### The general purpose I/O pins (GP0 to GP5) and I<sup>2</sup>C-bus expander option

The UDA1335H has 6 General Purpose (GP) I/O pins; these are pins GP0 to GP5. These can be used either for digital I/O functions or for general purposes.

There are basically three port configurations:

- No digital I/O communication
- 4-pin digital I/O communication
- 6-pin digital I/O communication.

## Universal Serial Bus (USB) Audio Playback Recording Peripheral (APRP)

UDA1335H

These port configurations can be chosen via the configuration map at start-up of the UDA1335H.

The user can also make use of an I<sup>2</sup>C-bus expander. The usage of an I<sup>2</sup>C-bus expander (yes/no) can be indicated via the configuration map. Some of the supported HID functions are located in the I<sup>2</sup>C-bus expander. If this expander is not used, the HID functions normally located in the expander must be declared as “unassigned” in the HID report descriptor. The bit which indicates if an external expander is used must then be put on zero.

**Table 11** Definition of the general purpose pins and I<sup>2</sup>C-bus expander pins; notes 1 to 6

PINS	NO I <sup>2</sup> S-BUS USAGE	4-PIN I <sup>2</sup> S-BUS USAGE	6-PIN I <sup>2</sup> S-BUS USAGE
<b>General purpose I/O</b>			
GP5	connect/disconnect	connect/disconnect	WS input
GP4	HID input 2	BCK output	BCK output
GP3	HID input 1	WS output	WS output
GP2	selector output	DATA output	DATA output
GP1	mute or standby output	DATA input	DATA input
GP0	interrupt input	interrupt input	BCK input
<b>I<sup>2</sup>C-bus expander; note 7</b>			
P0	HID input 3	HID input 3	connect/disconnect
P1	HID input 4	HID input 4	HID input 4
P2	HID input 5	HID input 5	HID input 5
P3	HID input 6	HID input 6	HID input 6
P4	output pin 1	output pin 1	output pin 1
P5	output pin 2	output pin 2	output pin 2
P6	output pin 3	selector output	selector output
P7	mute or standby output	mute or standby output	mute or standby output

### Notes

1. Connect/disconnect: This pin can be used to avoid malfunction during initialisation phase of the UDA1335H. While initialization takes place, the USB can be kept disconnected while the software of the microcontroller reads in the configuration map. When the UDA1335H is ready, the USB becomes connected and enumeration can start. Using the 6-pin I<sup>2</sup>S-bus, the connect/disconnect will be moved to the I<sup>2</sup>C-bus expander.
2. HID input 1 to 6 and interrupt input: A change on the expander can be signalled to the UDA1335H via the interrupt input. After detecting this signal the UDA1335H will decode the buttons. When no expander is used, the interrupt pin must be connected to the ground. The HID input pins and the interrupt input pin on the UDA1335H are scanned each 20 ms. If the interrupt in pin indicates a change on the expander, the expander input pins are scanned once. Using the 6-pin I<sup>2</sup>S-bus, the interrupt pin is not available and the inputs on the expander are scanned every 20 ms. All input pins must have a pull-up resistor.
3. Selector output: This pin can be used for switching the audio selector as illustrated in Fig.4. If the configuration map does not request this output pin, the output is always LOW.
4. Mute output: This output is activated if the isochronous signal is not available during a certain time. The output levels and the time are programmable in the configuration map.
5. Standby output: This output is activated if the UDA1335H is muted during a certain time. The output levels and the time are programmable in the configuration map.
6. Output pins 1 to 3: All the output pins are set via the I<sup>2</sup>C-bus. The function is according the configuration map.
7. For the I<sup>2</sup>C-bus expander, the PCF8574P remote 8-bit I/O expander for I<sup>2</sup>C-bus can be used.

# Universal Serial Bus (USB) Audio Playback Recording Peripheral (APRP)

UDA1335H

## Filter characteristics

The overall filter characteristic of the UDA1335H in flat mode is given in the Fig.7. The overall filter characteristic of the UDA1335H includes the filter characteristics of the DSP in flat mode plus the filter characteristic of the FSDAC ( $f_s = 44.1 \text{ kHz}$ )

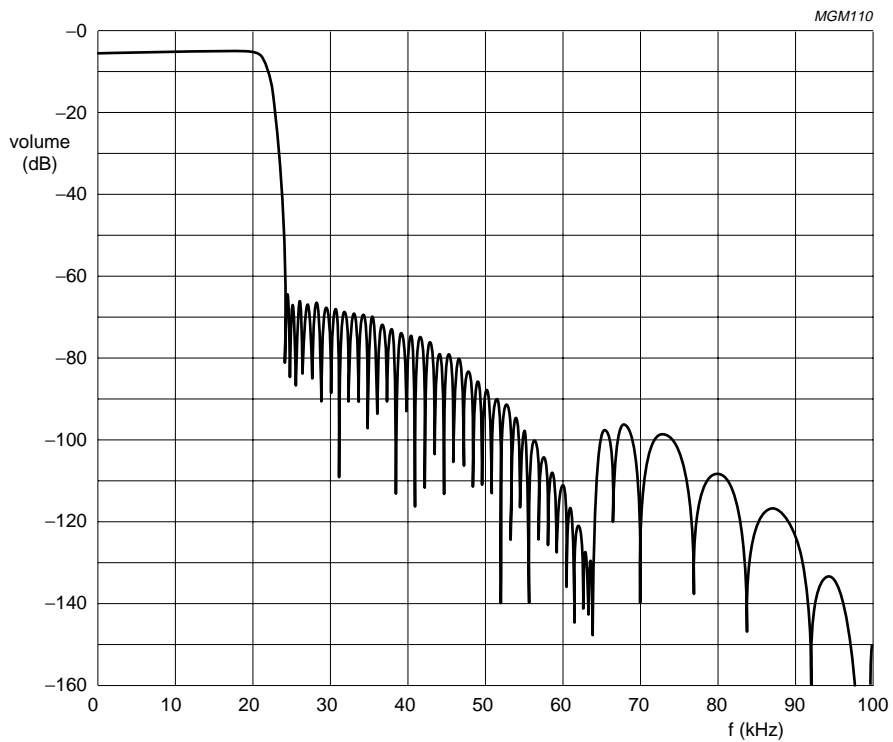

Fig.7 Overall filter characteristics of the UDA1335H.

Universal Serial Bus (USB) Audio  
Playback Recording Peripheral (APRP)

UDA1335H

DSP extension port

An external DSP can be used for adding extra sound processing features via the digital I/O-bus. The UDA1335H supports the standard I<sup>2</sup>S-bus data protocol and the LSB-justified serial data input format with word lengths of 16, 18 and 20 bits. Using the 4-pin digital I/O-bus the UDA1335H device acts as a master, controlling the BCK and WS signals.

The period of the WS signal is determined by the number of samples in the 1 ms frame of the USB. This implies that the WS signal does not have a constant time period, but is jittery. Using the 6-pin digital I/O-pins GP2, GP3 and GP4 are output pins (master) and GP0, GP1 and GP5 are input pins (slave).

The characteristic timing of the I<sup>2</sup>S-bus input interface is illustrated in Figs 8 and 9.

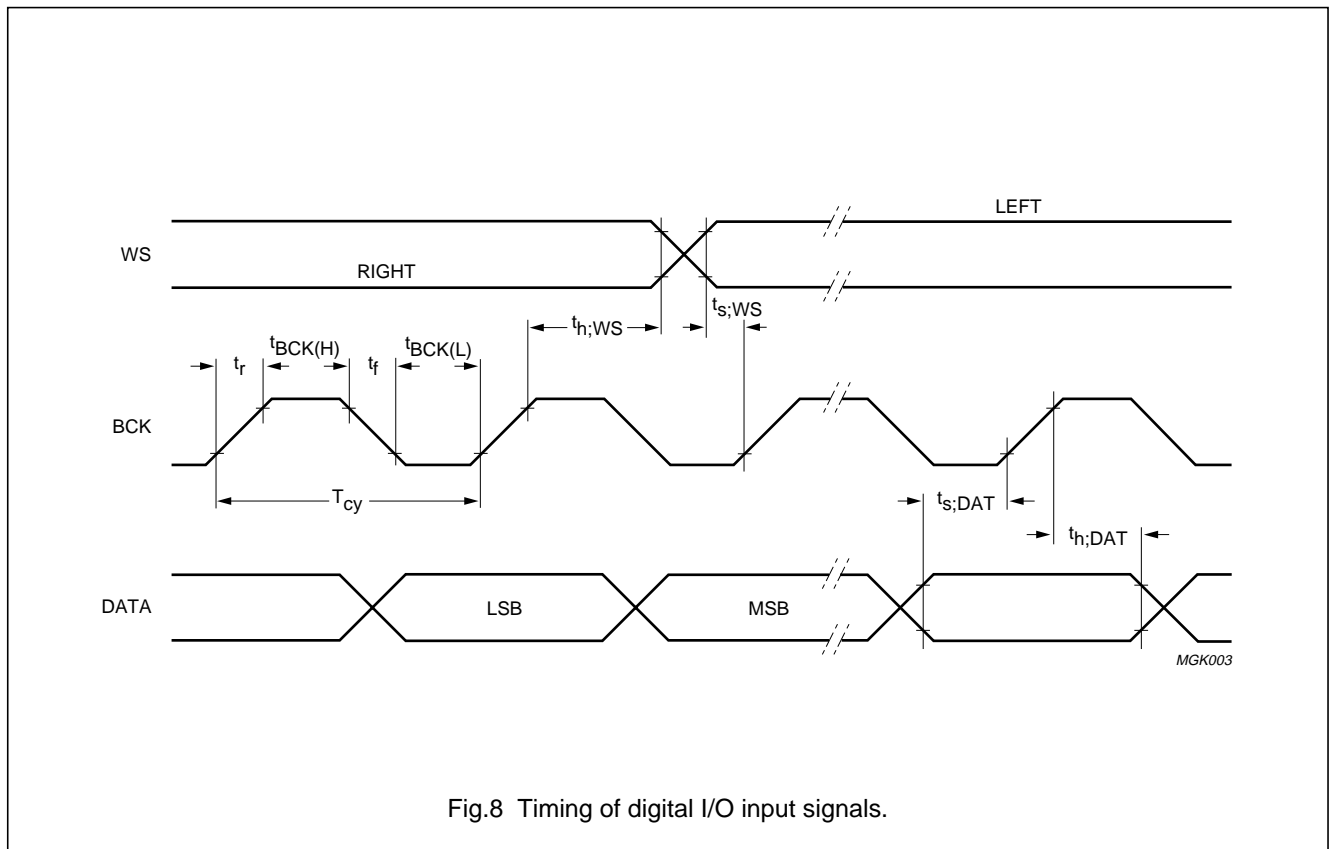

Fig.8 Timing of digital I/O input signals.

# Universal Serial Bus (USB) Audio Playback Recording Peripheral (APRP)

UDA1335H

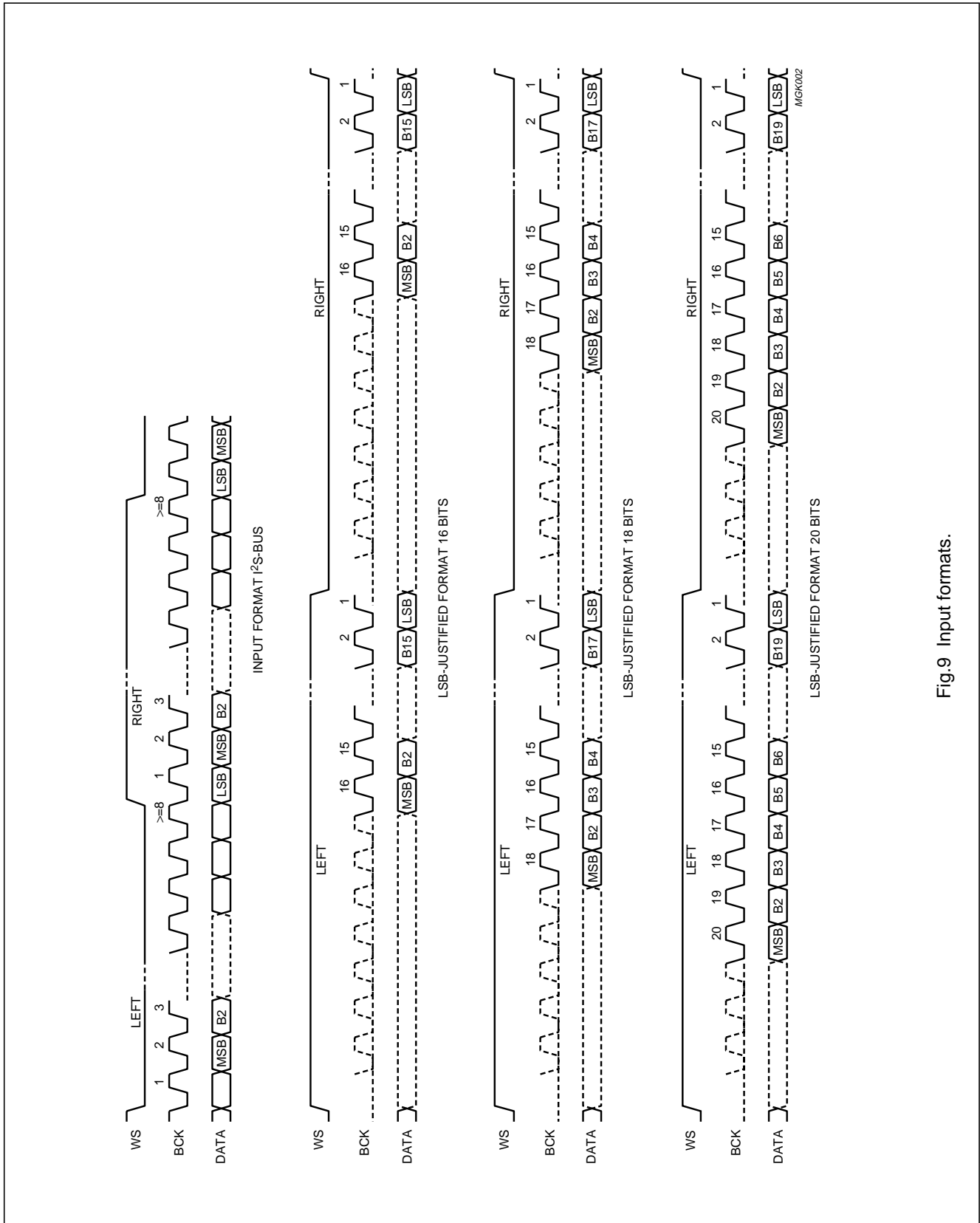

Fig.9 Input formats.

# Universal Serial Bus (USB) Audio Playback Recording Peripheral (APRP)

UDA1335H

## LIMITING VALUES

In accordance with the Absolute Maximum Rating System (IEC 134).

SYMBOL	PARAMETER	CONDITIONS	MIN.	TYP.	MAX.	UNIT
<b>All digital I/Os</b>						
$V_{I/O}$	DC input/output voltage range		-0.5	–	$V_{DDE}$	V
$I_O$	output current	$V_{DDE} = 5.0\text{ V}$	–	–	4	mA
<b>Temperature values</b>						
$T_j$	junction temperature		0	–	125	°C
$T_{stg}$	storage temperature		-55	–	+150	°C
$T_{amb}$	operating ambient temperature		0	25	70	°C
<b>Electrostatic handling</b>						
$V_{es}$	electrostatic handling	note 1	-3000	–	+3000	V
		note 2	-300	–	+300	V

## Notes

- Equivalent to discharging a 100 pF capacitor through a 1.5 k $\Omega$  series resistor.
- Equivalent to discharging a 200 pF capacitor through a 2.5  $\mu$ H series conductor.

## THERMAL CHARACTERISTICS

SYMBOL	PARAMETER	CONDITIONS	VALUE	UNIT
$R_{thj-a}$	thermal resistance from junction to ambient	in free air	48	K/W

## RECOMMENDED OPERATING CONDITIONS

SYMBOL	PARAMETER	MIN.	TYP.	MAX.	UNIT
$V_{DDE}$	supply voltage periphery (I/O)	4.75	5.0	5.25	V
$V_{DD}$	supply voltage (core)	3.0	3.3	3.6	V
$V_I$	DC input voltage range				
	for D+ and D–	0.0	–	$V_{DD}$	V
	for VINL and VINR	–	0.5 $V_{DD}$	–	V
	for digital I/Os	0.0	–	$V_{DDE}$	V

# Universal Serial Bus (USB) Audio Playback Recording Peripheral (APRP)

UDA1335H

**DC CHARACTERISTICS**
 $V_{DDE} = 5.0 \text{ V}$ ;  $V_{DD} = 3.3 \text{ V}$ ;  $T_{\text{amb}} = 25 \text{ }^\circ\text{C}$ ;  $f_{\text{osc}} = 48 \text{ MHz}$ ;  $f_s = 44.1 \text{ kHz}$ ; unless otherwise specified.

SYMBOL	PARAMETER	CONDITIONS	MIN.	TYP.	MAX.	UNIT
<b>Supplies</b>						
$V_{DDE}$	digital supply voltage periphery		4.75	5.0	5.25	V
$V_{DDI}$	digital supply voltage core		3.0	3.3	3.6	V
$V_{DDA1}$	analog supply voltage 1		3.0	3.3	3.6	V
$V_{DDA2}$	analog supply voltage 2		3.0	3.3	3.6	V
$V_{DDA3}$	analog supply voltage 3		3.0	3.3	3.6	V
$V_{DDO}$	operational amplifier supply voltage		3.0	3.3	3.6	V
$V_{DDX}$	crystal oscillator supply voltage		3.0	3.3	3.6	V
$I_{DDE}$	digital supply current periphery	note 1	–	3.7	–	mA
$I_{DDI}$	digital supply current core		–	39.0	–	mA
$I_{DDA1}$	analog supply current 1		–	3.6	–	mA
$I_{DDA2}$	analog supply current 2		–	8.0	–	mA
$I_{DDA3}$	analog supply current 3		–	0.9	9.0 <sup>(2)</sup>	mA
$I_{DDO}$	operational amplifier supply current		–	3.0	–	mA
$I_{DDX}$	crystal oscillator supply current		–	1.2	13.0 <sup>(3)</sup>	mA
$P_{\text{tot}}$	total power dissipation		–	200	–	mW
$P_{\text{ps}}$	total power dissipation in power saving mode	note 4	–	1.2	–	mW
<b>Inputs/outputs D+ and D–</b>						
$V_I$	static DC input voltage		–0.5	–	$V_{DDI}$	V
$V_{O(H)}$	static DC output voltage HIGH	$R_L = 15 \text{ k}\Omega$ connected to GND	2.8	–	3.6	V
$V_{O(L)}$	static DC output voltage LOW	$R_L = 15 \text{ k}\Omega$ connected to $V_{DD}$	–	–	0.3	V
$ I_{LO} $	high impedance data line output leakage current		–	–	10	$\mu\text{A}$
$V_{I(\text{diff})}$	differential input sensitivity		0.2	–	–	V
$V_{CM(\text{diff})}$	differential common mode range		0.8	–	2.5	V
$V_{SE(R)(\text{th})}$	single-ended receiver threshold voltage		0.8	–	2.0	V
$C_{IN}$	transceiver input capacitance	pin to GND	–	–	20	pF



# Universal Serial Bus (USB) Audio Playback Recording Peripheral (APRP)

UDA1335H

SYMBOL	PARAMETER	CONDITIONS	MIN.	TYP.	MAX.	UNIT
<b>Digital input pins</b>						
$V_{IL}$	LOW-level input voltage		–	–	$0.3V_{DDE}$	V
$V_{IH}$	HIGH-level input voltage		$0.7V_{DDE}$	–	$V_{DDE}$	V
$ I_{LI} $	input leakage current		–	–	1	$\mu A$
$C_I$	input capacitance		–	–	5	pF
<b>PGA and ADC</b>						
$V_{ref(AD)}$	reference voltage PGA and ADC		–	$0.5V_{DDA2}$	–	V
$V_{ref(ADC)(pos)}$	positive reference voltage of the ADC		–	$V_{DDA2}$	–	V
$V_{ref(ADC)(neg)}$	negative reference voltage of the ADC		–	0.0	–	V
$V_{I(PGA)}$	DC input voltage VINL and VINR of the PGA		–	$0.5V_{DDA2}$	–	V
$R_{I(PGA)}$	DC input resistance at VINL and VINR of the PGA		–	12.5	–	k $\Omega$
<b>Filter stream DAC</b>						
$V_{ref(DA)}$	reference voltage DAC		–	$0.5V_{DDA1}$	–	V
$V_{O(CM)}$	common mode output voltage		–	$0.5V_{DDA1}$	–	V
$R_{O(VOUT)}$	output resistance at VOUTL and VOUTR		–	11	–	$\Omega$
$R_{O(L)}$	output load resistance		2.0	–	–	k $\Omega$
$C_{O(L)}$	output load capacitance		–	–	50	pF

**Notes**

1. This value depends strongly on the application. The specified value is the typical value obtained using the application diagram as illustrated in Fig.10.
2. At start-up of the OSCAD oscillator.
3. At start-up of the OSC48 oscillator.
4. Exclusive the  $I_{DDE}$  current which depends on the components connected to the I/O pins.

# Universal Serial Bus (USB) Audio Playback Recording Peripheral (APRP)

UDA1335H

**AC CHARACTERISTICS**
 $V_{DDE} = 5.0\text{ V}$ ;  $V_{DDI} = 3.3\text{ V}$ ;  $T_{amb} = 25\text{ °C}$ ;  $f_{osc} = 48\text{ MHz}$ ;  $f_s = 44.1\text{ kHz}$ ; unless otherwise specified.

SYMBOL	PARAMETER	CONDITIONS	MIN.	TYP.	MAX.	UNIT
<b>Driver characteristics D+ and D- (full-speed mode)</b>						
$f_{o(s)}$	audio sample output frequency		5	–	55	kHz
$t_r$	rise time	$C_L = 50\text{ pF}$	4	–	20	ns
$t_f$	fall time	$C_L = 50\text{ pF}$	4	–	20	ns
$t_{rf(m)}$	rise/fall time matching ( $t_r/t_f$ )		90	–	110	%
$V_{cr}$	output signal crossover voltage		1.3	–	2.0	V
$R_{o(drive)}$	driver output resistance	steady-state drive	28	–	43	$\Omega$
<b>Data source timings D+ and D- (full-speed mode)</b>						
$f_{i(s)}$	audio sample input frequency		5	–	55	kHz
$f_{is(D)}$	full speed data rate		11.97	12.00	12.03	Mbits/s
$t_{fr(D)}$	frame interval		0.9995	1.0000	1.0005	ms
$t_{J1(diff)}$	source differential jitter to next transition		–3.5	+0.0	+3.5	ns
$t_{J2(diff)}$	source differential jitter for paired transitions		–4.0	+0.0	+4.0	ns
$t_{W(EOP)}$	source end of packet width		160	–	175	ns
$t_{EOP(diff)}$	differential to end of packet transition skew		–2.0	–	+5.0	ns
$t_{JR1}$	receiver data jitter tolerance to next transition		–18.5	0.0	+18.5	ns
$t_{JR2}$	receiver data jitter tolerance for paired transitions		–9.0	0.0	+9.0	ns
$t_{EOPR1}$	end of packet width at receiver must reject as end of packet		40	–	–	ns
$t_{EOPR2}$	end of packet width at receiver must accept as end of packet		82	–	–	ns
<b>Serial input/output data timing</b>						
$f_s$	system clock frequency		–	12	–	MHz
$f_{i(WS)}$	word selection input frequency		5	–	55	kHz
$t_r$	rise time		–	–	20	ns
$t_f$	fall time		–	–	20	ns
$t_{BCK(H)}$	bit clock HIGH time		55	–	–	ns
$t_{BCK(L)}$	bit clock LOW time		55	–	–	ns
$t_{s,DAT}$	data set-up time		10	–	–	ns
$t_{h,DAT}$	data hold time		20	–	–	ns
$t_{s,WS}$	word selection set-up time		20	–	–	ns
$t_{h,WS}$	word selection hold time		10	–	–	ns

# Universal Serial Bus (USB) Audio Playback Recording Peripheral (APRP)

UDA1335H

SYMBOL	PARAMETER	CONDITIONS	MIN.	TYP.	MAX.	UNIT
<b>SDA and SCL lines (standard mode I<sup>2</sup>C-bus)</b>						
f <sub>SCL</sub>	SCL clock frequency		0	–	100	kHz
t <sub>BUF</sub>	bus free time between a STOP and START condition		4.7	–	–	μs
t <sub>HD;STA</sub>	hold time (repeated) START condition		4.0	–	–	μs
t <sub>LOW</sub>	LOW period of the SCL clock		4.7	–	–	μs
t <sub>HIGH</sub>	HIGH period of the SCL clock		4.0	–	–	μs
t <sub>SU;STA</sub>	set-up time for a repeated START condition		4.7	–	–	μs
t <sub>SU;STO</sub>	set-up time for STOP condition		4.0	–	–	μs
t <sub>HD;DAT</sub>	data hold time		5.0	–	0.9	μs
t <sub>SU;DAT</sub>	data set-up time		250	–	–	ns
t <sub>r</sub>	rise time of both SDA and SCL signals		–	–	1000	ns
t <sub>f</sub>	fall time of both SDA and SCL signals		–	–	300	ns
C <sub>L(bus)</sub>	capacitive load for each bus line		–	–	400	pF
<b>Oscillator 1 (system clock)</b>						
f <sub>osc</sub>	oscillator frequency		–	48	–	MHz
δ	duty factor		–	50	–	%
g <sub>m</sub>	transconductance		12.8	22.1	30.2	mS
R <sub>o</sub>	output resistance		0.6	1.1	2.3	kΩ
C <sub>i(XTAL1a)</sub>	parasitic input capacitance XTAL1a		4.5	4.8	5.2	pF
C <sub>i(XTAL2a)</sub>	parasitic input capacitance XTAL2a		4.1	4.6	5.0	pF
I <sub>start</sub>	start-up current		3.7	7.6	13.0	mA
<b>Oscillator 2 (for ADC clock)</b>						
f <sub>osc</sub>	oscillator frequency		8.192	–	14.08	MHz
δ	duty cycle		–	50	–	%
g <sub>m</sub>	transconductance		8.1	13.6	18.1	mA/V
R <sub>o</sub>	output resistance		1.3	2.0	4.0	kΩ
C <sub>i(XTAL1b)</sub>	parasitic input capacitance XTAL1b		5.0	5.4	5.7	pF
C <sub>i(XTAL2b)</sub>	parasitic input capacitance XTAL2b		4.1	4.6	5.0	pF
I <sub>start</sub>	start-up current		2.4	5.0	8.4	mA

# Universal Serial Bus (USB) Audio Playback Recording Peripheral (APRP)

UDA1335H

SYMBOL	PARAMETER	CONDITIONS	MIN.	TYP.	MAX.	UNIT
<b>Analog PLL (for ADC clock)</b>						
$f_{\text{clk(PLL)}}$	PLL clock frequency		8.1920	11.2896	12.2880	MHz
$\delta$	duty factor		–	50	–	%
$t_{\text{str}(PO)}$	start-up time after power-on		–	–	10	ms
<b>Power-on reset</b>						
$t_{\text{su}(PO)}$	power-on set-up-time	note 1	$5C_{\text{ref}}^{(2)}$	–	–	ms
<b>PGA and ADC</b>						
$V_{i(\text{FS})(\text{rms})}$	full-scale input voltage (RMS value)	PGA gain = –3 dB	–	1414 <sup>(5)</sup>	–	mV
		PGA gain = 0 dB	–	1000	–	mV
		PGA gain = 3 dB	–	708	–	mV
		PGA gain = 9 dB	–	355	–	mV
		PGA gain = 15 dB	–	178	–	mV
		PGA gain = 21 dB	–	89	–	mV
		PGA gain = 27 dB	–	44	–	mV
$C_{i(\text{PGA})}$	input capacitance of the PGA		–	–	20	pF
(THD + N)/S	total harmonic distortion plus noise-to-signal ratio	$f_s = 44.1$ kHz at input signal of 1 kHz; PGA gain = 0 dB; note 3				
		$V_i$ (0 dB) (1.0 V RMS)	–	–85	–80	dB
			–	0.0056	0.01	%
		$V_i$ (–60 dB)	–	–30	–20	dB
		–	3.2	10.0	%	
S/N	signal to noise ratio	$V_i = 0.0$ V	90	95	–	dBA
$\alpha_{\text{ct}}$	crosstalk between channels	PGA gain = 0 dB	–	100	–	dB
$f_s$	sample frequency ( $128f_s$ )		0.640	–	7.04	MHz
$OL_{(\text{FS})}$	full-scale digital output level	PGA gain = 0 dB; $V_i = 1$ V (RMS)	–	–2.0	–	dB

# Universal Serial Bus (USB) Audio Playback Recording Peripheral (APRP)

UDA1335H

SYMBOL	PARAMETER	CONDITIONS	MIN.	TYP.	MAX.	UNIT
<b>Filter stream DAC</b>						
RES	resolution		16	–	–	bits
$V_{o(FS)(rms)}$	full-scale output voltage (RMS value)	$V_{DD} = 3.3\text{ V}$	–	0.66	–	V
SVRR	supply voltage ripple rejection at $V_{DDA}$ and $V_{DDO}$	$f_{ripple} = 1\text{ kHz};$ $V_{ripple(p-p)} = 0.1\text{ V}$	–	60	–	dB
$ \Delta V_o $	channel unbalance	maximum volume	–	0.03	–	dB
$\alpha_{ct}$	crosstalk between channels	$R_L = 5\text{ k}\Omega$	–	95	–	dB
(THD + N)/S	total harmonic distortion plus noise-to-signal ratio	$f_s = 44.1\text{ kHz};$ $R_L = 5\text{ k}\Omega;$ note 4 at input signal of 1 kHz (0 dB) at input signal of 1 kHz (–60 dB)	– – – –	–90 0.0032 –30 3.2	–80 0.01	dB % dB %
S/N	signal-to-noise ratio at bipolar zero	A-weighting at code 0000H	90	95	–	dB

**Notes**

1. Strongly depends on the external decoupling capacitor connected to  $V_{ref(DA)}$ .
2.  $C_{ref}$  in  $\mu\text{F}$ .
3. Measured with the APLL as ADC clock source.
4. Measured with I<sup>2</sup>S-bus input as digital source.
5. Although a level of 1.414 V (RMS) would be required to optimal drive the ADC in this gain setting, this level can not be used. Due to the 3.3 V supply voltage input, signals of 1.17 V (RMS) and higher will result in clipping.

**APPLICATION INFORMATION**

The UDA1335H can only be used in combination with an external (E)PROM. This (E)PROM can be connected to the port pins (P0 and P2) of the UDA1335H and must contain the firmware for the microcontroller. The UDA1335H will be delivered with standard USB compliant firmware. The I<sup>2</sup>C-bus EEPROM is optional and can be used to configure client specific configurations and descriptors.

More information about the firmware, descriptors and configurations can be obtained from several application notes.

# Universal Serial Bus (USB) Audio Playback Recording Peripheral (APRP)

## UDA1335H

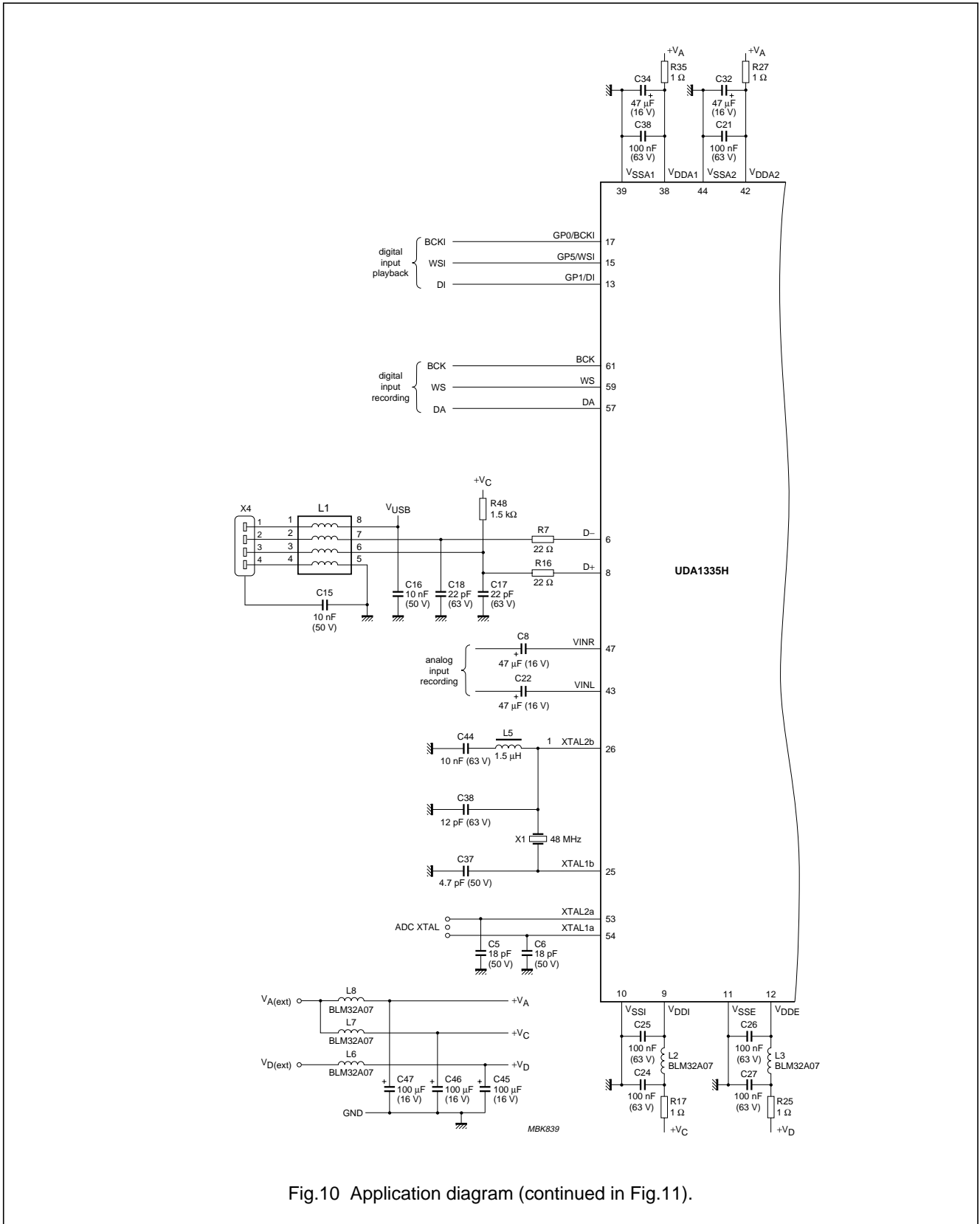

Fig.10 Application diagram (continued in Fig.11).

# Universal Serial Bus (USB) Audio Playback Recording Peripheral (APRP)

## UDA1335H

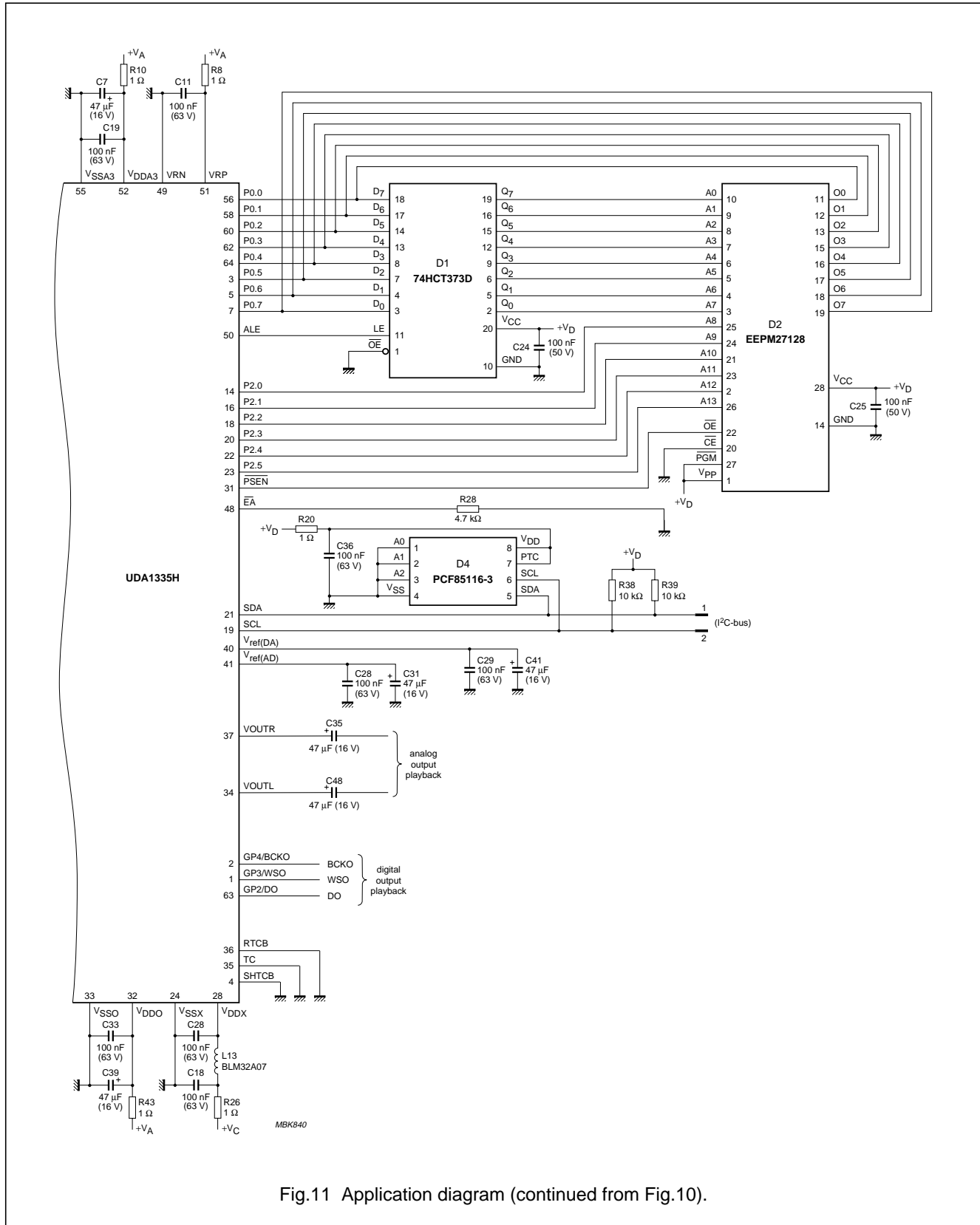

Fig.11 Application diagram (continued from Fig.10).

# Universal Serial Bus (USB) Audio Playback Recording Peripheral (APRP)

UDA1335H

## PACKAGE OUTLINE

QFP64: plastic quad flat package; 64 leads (lead length 1.95 mm); body 14 x 20 x 2.8 mm

SOT319-2

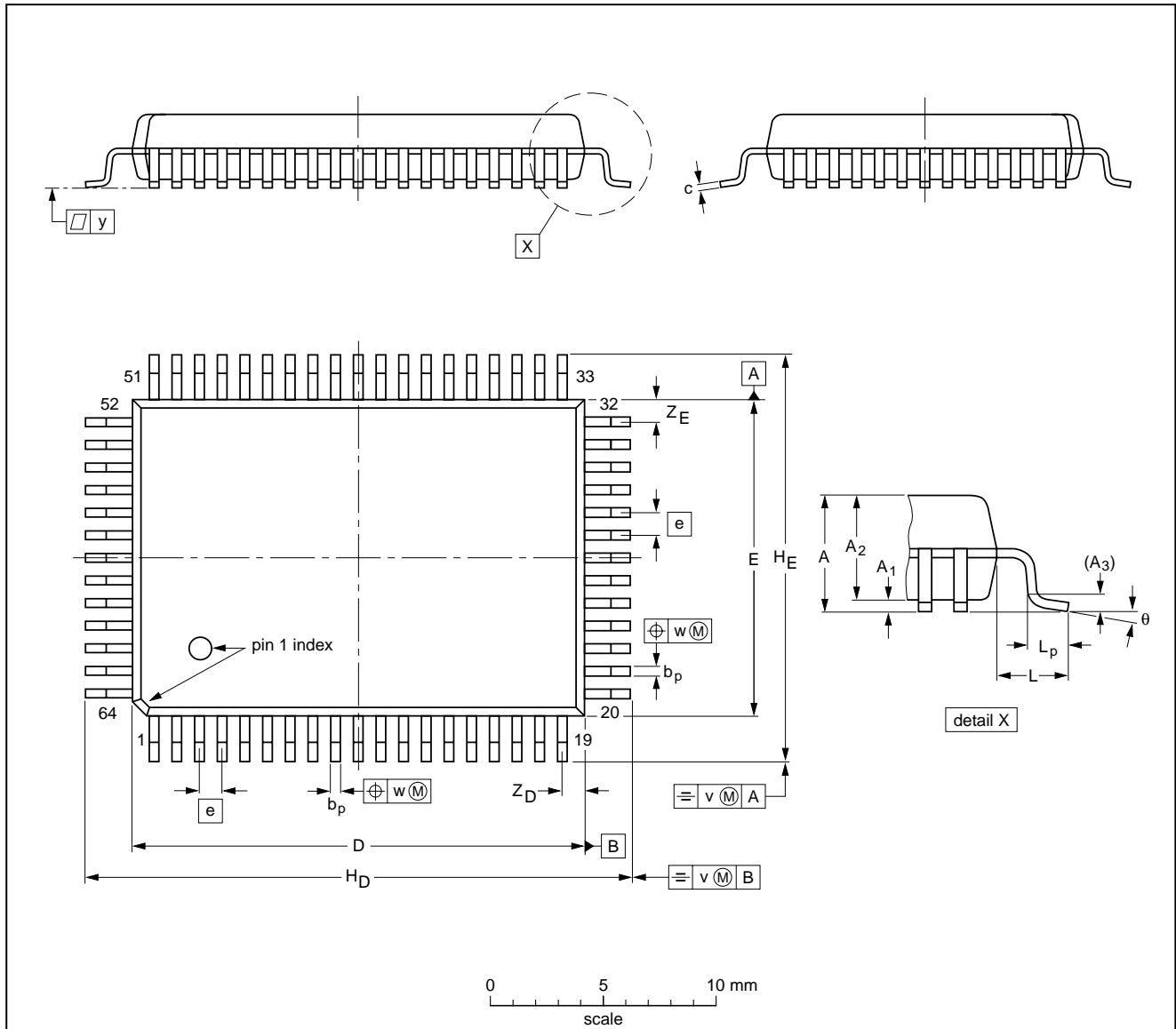

**DIMENSIONS (mm are the original dimensions)**

UNIT	A max.	A <sub>1</sub>	A <sub>2</sub>	A <sub>3</sub>	b <sub>p</sub>	c	D <sup>(1)</sup>	E <sup>(1)</sup>	e	H <sub>D</sub>	H <sub>E</sub>	L	L <sub>p</sub>	v	w	y	Z <sub>D</sub> <sup>(1)</sup>	Z <sub>E</sub> <sup>(1)</sup>	θ
mm	3.20	0.25 0.05	2.90 2.65	0.25	0.50 0.35	0.25 0.14	20.1 19.9	14.1 13.9	1	24.2 23.6	18.2 17.6	1.95	1.0 0.6	0.2	0.2	0.1	1.2 0.8	1.2 0.8	7° 0°

**Note**

1. Plastic or metal protrusions of 0.25 mm maximum per side are not included.

OUTLINE VERSION	REFERENCES				EUROPEAN PROJECTION	ISSUE DATE
	IEC	JEDEC	EIAJ			
SOT319-2						95-02-04 97-08-01



## Universal Serial Bus (USB) Audio Playback Recording Peripheral (APRP)

UDA1335H

### SOLDERING

#### Introduction

There is no soldering method that is ideal for all IC packages. Wave soldering is often preferred when through-hole and surface mounted components are mixed on one printed-circuit board. However, wave soldering is not always suitable for surface mounted ICs, or for printed-circuits with high population densities. In these situations reflow soldering is often used.

This text gives a very brief insight to a complex technology. A more in-depth account of soldering ICs can be found in our *"Data Handbook IC26; Integrated Circuit Packages"* (order code 9398 652 90011).

#### Reflow soldering

Reflow soldering techniques are suitable for all QFP packages.

The choice of heating method may be influenced by larger plastic QFP packages (44 leads, or more). If infrared or vapour phase heating is used and the large packages are not absolutely dry (less than 0.1% moisture content by weight), vaporization of the small amount of moisture in them can cause cracking of the plastic body. For details, refer to the Drypack information in the *"Data Handbook IC26; Integrated Circuit Packages; Section: Packing Methods"*.

Reflow soldering requires solder paste (a suspension of fine solder particles, flux and binding agent) to be applied to the printed-circuit board by screen printing, stencilling or pressure-syringe dispensing before package placement.

Several methods exist for reflowing; for example, infrared/convection heating in a conveyor type oven. Throughput times (preheating, soldering and cooling) vary between 50 and 300 seconds depending on heating method. Typical reflow peak temperatures range from 215 to 250 °C.

#### Wave soldering

Wave soldering is **not** recommended for QFP packages. This is because of the likelihood of solder bridging due to closely-spaced leads and the possibility of incomplete solder penetration in multi-lead devices.

**If wave soldering cannot be avoided, for QFP packages with a pitch (e) larger than 0.5 mm, the following conditions must be observed:**

- **A double-wave (a turbulent wave with high upward pressure followed by a smooth laminar wave) soldering technique should be used.**
- **The footprint must be at an angle of 45° to the board direction and must incorporate solder thieves downstream and at the side corners.**

During placement and before soldering, the package must be fixed with a droplet of adhesive. The adhesive can be applied by screen printing, pin transfer or syringe dispensing. The package can be soldered after the adhesive is cured.

Maximum permissible solder temperature is 260 °C, and maximum duration of package immersion in solder is 10 seconds, if cooled to less than 150 °C within 6 seconds. Typical dwell time is 4 seconds at 250 °C.

A mildly-activated flux will eliminate the need for removal of corrosive residues in most applications.

#### Repairing soldered joints

Fix the component by first soldering two diagonally-opposite end leads. Use only a low voltage soldering iron (less than 24 V) applied to the flat part of the lead. Contact time must be limited to 10 seconds at up to 300 °C. When using a dedicated tool, all other leads can be soldered in one operation within 2 to 5 seconds between 270 and 320 °C.

CAUTION
Wave soldering is NOT applicable for all QFP packages with a pitch (e) equal or less than 0.5 mm.

# Universal Serial Bus (USB) Audio Playback Recording Peripheral (APRP)

UDA1335H

## DEFINITIONS

<b>Data sheet status</b>	
Objective specification	This data sheet contains target or goal specifications for product development.
Preliminary specification	This data sheet contains preliminary data; supplementary data may be published later.
Product specification	This data sheet contains final product specifications.
<b>Limiting values</b>	
Limiting values given are in accordance with the Absolute Maximum Rating System (IEC 134). Stress above one or more of the limiting values may cause permanent damage to the device. These are stress ratings only and operation of the device at these or at any other conditions above those given in the Characteristics sections of the specification is not implied. Exposure to limiting values for extended periods may affect device reliability.	
<b>Application information</b>	
Where application information is given, it is advisory and does not form part of the specification.	

## LIFE SUPPORT APPLICATIONS

These products are not designed for use in life support appliances, devices, or systems where malfunction of these products can reasonably be expected to result in personal injury. Philips customers using or selling these products for use in such applications do so at their own risk and agree to fully indemnify Philips for any damages resulting from such improper use or sale.

## PURCHASE OF PHILIPS I<sup>2</sup>C COMPONENTS



Purchase of Philips I<sup>2</sup>C components conveys a license under the Philips' I<sup>2</sup>C patent to use the components in the I<sup>2</sup>C system provided the system conforms to the I<sup>2</sup>C specification defined by Philips. This specification can be ordered using the code 9398 393 40011.

---

Universal Serial Bus (USB) Audio  
Playback Recording Peripheral (APRP)

---

UDA1335H

**NOTES**

# Philips Semiconductors – a worldwide company

**Argentina:** see South America

**Australia:** 34 Waterloo Road, NORTH RYDE, NSW 2113,  
Tel. +61 2 9805 4455, Fax. +61 2 9805 4466

**Austria:** Computerstr. 6, A-1101 WIEN, P.O. Box 213, Tel. +43 160 1010,  
Fax. +43 160 101 1210

**Belarus:** Hotel Minsk Business Center, Bld. 3, r. 1211, Volodarski Str. 6,  
220050 MINSK, Tel. +375 172 200 733, Fax. +375 172 200 773

**Belgium:** see The Netherlands

**Brazil:** see South America

**Bulgaria:** Philips Bulgaria Ltd., Energoproject, 15th floor,  
51 James Bourchier Blvd., 1407 SOFIA,  
Tel. +359 2 689 211, Fax. +359 2 689 102

**Canada:** PHILIPS SEMICONDUCTORS/COMPONENTS,  
Tel. +1 800 234 7381

**China/Hong Kong:** 501 Hong Kong Industrial Technology Centre,  
72 Tat Chee Avenue, Kowloon Tong, HONG KONG,  
Tel. +852 2319 7888, Fax. +852 2319 7700

**Colombia:** see South America

**Czech Republic:** see Austria

**Denmark:** Prags Boulevard 80, PB 1919, DK-2300 COPENHAGEN S,  
Tel. +45 32 88 2636, Fax. +45 31 57 0044

**Finland:** Sinikalliontie 3, FIN-02630 ESPOO,  
Tel. +358 9 615800, Fax. +358 9 61580920

**France:** 51 Rue Carnot, BP317, 92156 SURESNES Cedex,  
Tel. +33 1 40 99 6161, Fax. +33 1 40 99 6427

**Germany:** Hammerbrookstraße 69, D-20097 HAMBURG,  
Tel. +49 40 23 53 60, Fax. +49 40 23 536 300

**Greece:** No. 15, 25th March Street, GR 17778 TAVROS/ATHENS,  
Tel. +30 1 4894 339/239, Fax. +30 1 4814 240

**Hungary:** see Austria

**India:** Philips INDIA Ltd, Band Box Building, 2nd floor,  
254-D, Dr. Annie Besant Road, Worli, MUMBAI 400 025,  
Tel. +91 22 493 8541, Fax. +91 22 493 0966

**Indonesia:** PT Philips Development Corporation, Semiconductors Division,  
Gedung Philips, Jl. Buncit Raya Kav.99-100, JAKARTA 12510,  
Tel. +62 21 794 0040 ext. 2501, Fax. +62 21 794 0080

**Ireland:** Newstead, Clonskeagh, DUBLIN 14,  
Tel. +353 1 7640 000, Fax. +353 1 7640 200

**Israel:** RAPAC Electronics, 7 Kehilat Saloniki St, PO Box 18053,  
TEL AVIV 61180, Tel. +972 3 645 0444, Fax. +972 3 649 1007

**Italy:** PHILIPS SEMICONDUCTORS, Piazza IV Novembre 3,  
20124 MILANO, Tel. +39 2 6752 2531, Fax. +39 2 6752 2557

**Japan:** Philips Bldg 13-37, Kohnan 2-chome, Minato-ku,  
TOKYO 108-8507, Tel. +81 3 3740 5130, Fax. +81 3 3740 5077

**Korea:** Philips House, 260-199 Itaewon-dong, Yongsan-ku, SEOUL,  
Tel. +82 2 709 1412, Fax. +82 2 709 1415

**Malaysia:** No. 76 Jalan Universiti, 46200 PETALING JAYA, SELANGOR,  
Tel. +60 3 750 5214, Fax. +60 3 757 4880

**Mexico:** 5900 Gateway East, Suite 200, EL PASO, TEXAS 79905,  
Tel. +9-5 800 234 7381

**Middle East:** see Italy

**Netherlands:** Postbus 90050, 5600 PB EINDHOVEN, Bldg. VB,  
Tel. +31 40 27 82785, Fax. +31 40 27 88399

**New Zealand:** 2 Wagener Place, C.P.O. Box 1041, AUCKLAND,  
Tel. +64 9 849 4160, Fax. +64 9 849 7811

**Norway:** Box 1, Manglerud 0612, OSLO,  
Tel. +47 22 74 8000, Fax. +47 22 74 8341

**Pakistan:** see Singapore

**Philippines:** Philips Semiconductors Philippines Inc.,  
106 Valero St. Salcedo Village, P.O. Box 2108 MCC, MAKATI,  
Metro MANILA, Tel. +63 2 816 6380, Fax. +63 2 817 3474

**Poland:** Ul. Lukiska 10, PL 04-123 WARSZAWA,  
Tel. +48 22 612 2831, Fax. +48 22 612 2327

**Portugal:** see Spain

**Romania:** see Italy

**Russia:** Philips Russia, Ul. Usatcheva 35A, 119048 MOSCOW,  
Tel. +7 095 755 6918, Fax. +7 095 755 6919

**Singapore:** Lorong 1, Toa Payoh, SINGAPORE 319762,  
Tel. +65 350 2538, Fax. +65 251 6500

**Slovakia:** see Austria

**Slovenia:** see Italy

**South Africa:** S.A. PHILIPS Pty Ltd., 195-215 Main Road Martindale,  
2092 JOHANNESBURG, P.O. Box 7430 Johannesburg 2000,  
Tel. +27 11 470 5911, Fax. +27 11 470 5494

**South America:** Al. Vicente Pinzon, 173, 6th floor,  
04547-130 SÃO PAULO, SP, Brazil,  
Tel. +55 11 821 2333, Fax. +55 11 821 2382

**Spain:** Balmes 22, 08007 BARCELONA,  
Tel. +34 93 301 6312, Fax. +34 93 301 4107

**Sweden:** Kottbygatan 7, Akalla, S-16485 STOCKHOLM,  
Tel. +46 8 5985 2000, Fax. +46 8 5985 2745

**Switzerland:** Allmendstrasse 140, CH-8027 ZÜRICH,  
Tel. +41 1 488 2741 Fax. +41 1 488 3263

**Taiwan:** Philips Semiconductors, 6F, No. 96, Chien Kuo N. Rd., Sec. 1,  
TAIPEI, Taiwan Tel. +886 2 2134 2865, Fax. +886 2 2134 2874

**Thailand:** PHILIPS ELECTRONICS (THAILAND) Ltd.,  
209/2 Sanpavuth-Bangna Road Prakanong, BANGKOK 10260,  
Tel. +66 2 745 4090, Fax. +66 2 398 0793

**Turkey:** Talatpasa Cad. No. 5, 80640 GÜLTEPE/ISTANBUL,  
Tel. +90 212 279 2770, Fax. +90 212 282 6707

**Ukraine:** PHILIPS UKRAINE, 4 Patrice Lumumba str., Building B, Floor 7,  
252042 KIEV, Tel. +380 44 264 2776, Fax. +380 44 268 0461

**United Kingdom:** Philips Semiconductors Ltd., 276 Bath Road, Hayes,  
MIDDLESEX UB3 5BX, Tel. +44 181 730 5000, Fax. +44 181 754 8421

**United States:** 811 East Arques Avenue, SUNNYVALE, CA 94088-3409,  
Tel. +1 800 234 7381

**Uruguay:** see South America

**Vietnam:** see Singapore

**Yugoslavia:** PHILIPS, Trg N. Pasica 5/v, 11000 BEOGRAD,  
Tel. +381 11 625 344, Fax. +381 11 635 777

**For all other countries apply to:** Philips Semiconductors,  
International Marketing & Sales Communications, Building BE-p, P.O. Box 218,  
5600 MD EINDHOVEN, The Netherlands, Fax. +31 40 27 24825

**Internet:** <http://www.semiconductors.philips.com>

© Philips Electronics N.V. 1998

SCA60

All rights are reserved. Reproduction in whole or in part is prohibited without the prior written consent of the copyright owner.

The information presented in this document does not form part of any quotation or contract, is believed to be accurate and reliable and may be changed without notice. No liability will be accepted by the publisher for any consequence of its use. Publication thereof does not convey nor imply any license under patent- or other industrial or intellectual property rights.

Printed in The Netherlands

545102/750/01/pp44

Date of release: 1998 Aug 28

Document order number: 9397 750 03922

*Let's make things better.*