

# RECTIFIERS

## High Efficiency, 5A

UES1304  
UES1305  
UES1306

### FEATURES

- Very Low Forward Voltage (1.15V)
- Very Fast Recovery Times (50nSec)
- Small Size
- High Surge

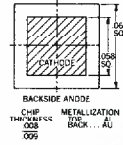

### DESCRIPTION

The UES1304 series is specifically designed for operation in power switching circuits operating at frequencies of at least 20 KHz.

### ABSOLUTE MAXIMUM RATINGS

Peak Inverse Voltage, UES1304	.....	200V
Peak Inverse Voltage, UES1305	.....	300V
Peak Inverse Voltage, UES1306	.....	400V
Maximum Average DC Output Current, I <sub>O</sub>		
@ T <sub>A</sub> = 25°C (Free Air)	.....	3A
@ T <sub>L</sub> = 50°C, L = 3/8"	.....	5A
Surge Current, 8.3mSec	.....	70A
Thermal Resistance @ L = 3/8"	.....	20°C/W
Operating and Storage Temperature Range	.....	-55°C to +150°C

### MECHANICAL SPECIFICATIONS

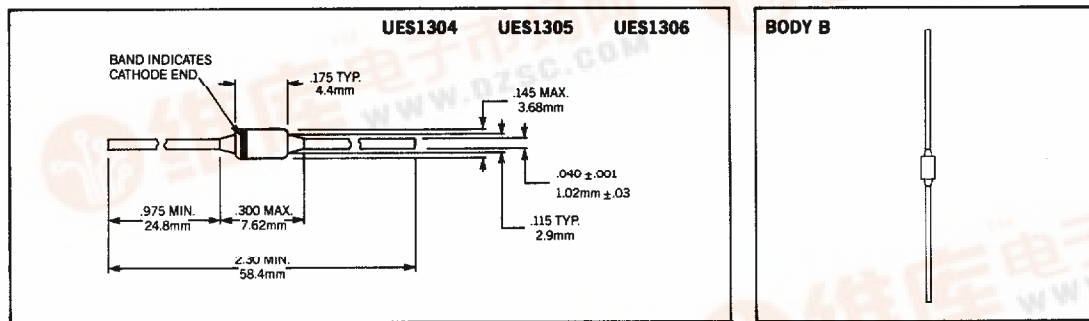

THESE DEVICES ALSO AVAILABLE IN SURFACE MOUNT PACKAGE. SEE SECTION 10

**Microsemi Corp.**  
**Watertown**  
The diode experts



**ELECTRICAL SPECIFICATIONS**

Type	PIV	Maximum Forward Voltage		Maximum Reverse Current		Maximum Reverse Recovery Time*
		$T_J = 25^\circ\text{C}$	$T_J = 100^\circ\text{C}$	@ PIV, $T_J = 25^\circ\text{C}$	$T_J = 100^\circ\text{C}$	
UES1304	200V	1.25V @ 3A	1.15V @ 3A	20 $\mu\text{A}$	500 $\mu\text{A}$	50nS
UES1305	300V					
UES1306	400V					

\* Measured in circuit  $I_F = 0.5\text{A}$ ,  $I_R = 1\text{A}$ ,  $t_{\text{REC}} = 0.25\mu\text{s}$

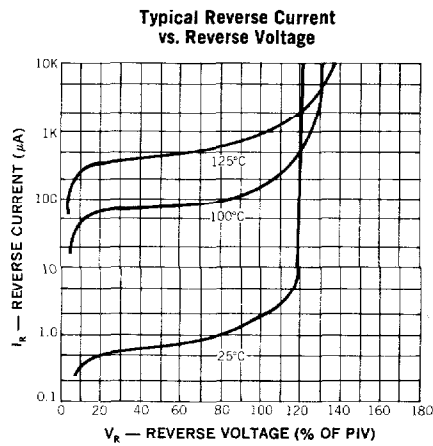
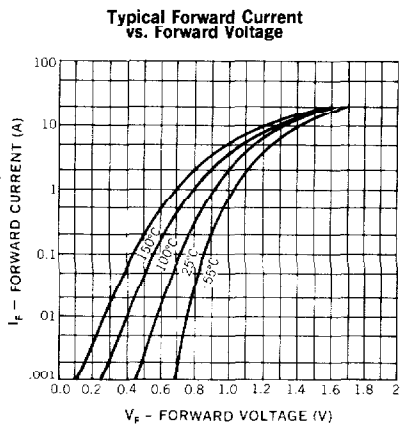
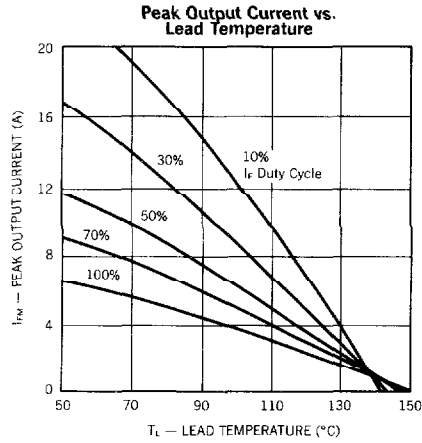
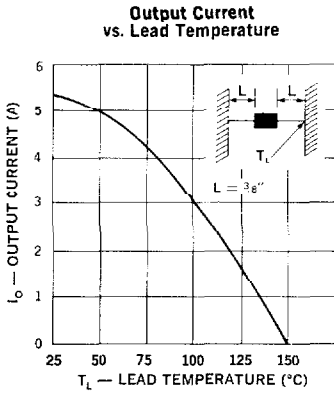

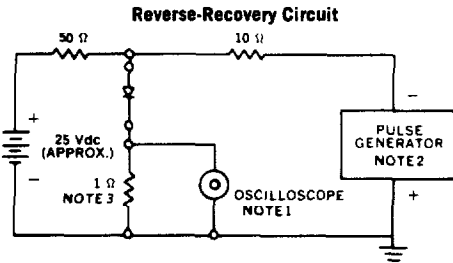
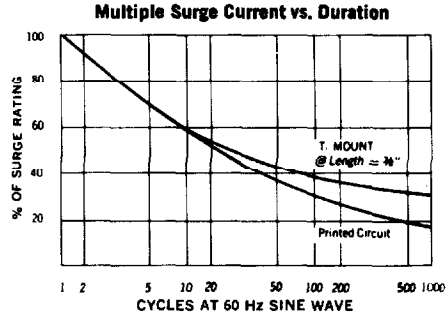
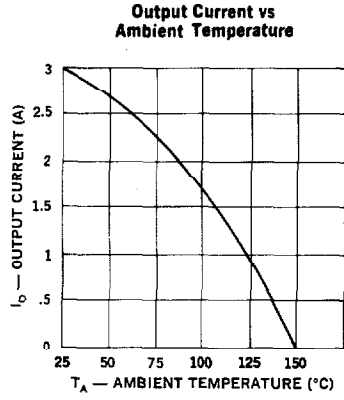

- NOTES:**
1. Oscilloscope: Rise time  $\leq 3ns$ ; input impedance =  $50\Omega$ .
  2. Pulse Generator: Rise time  $\leq 8ns$ ; source impedance  $10\Omega$ .
  3. Current viewing resistor, non-inductive, coaxial recommended.