



**TRANSYS
ELECTRONICS
LIMITED**

UF150 THRU UF1510

ULTRAFAST SWITCHING RECTIFIER

VOLTAGE - 50 to 1000 Volts CURRENT - 1.5 Amperes

FEATURES

- Plastic package has Underwriters Laboratory Flammability Classification 94V-0 utilizing Flame Retardant Epoxy Molding Compound
- Void-free Plastic in DO-15 package
- 1.5 ampere operation at $T_A=55^\circ\text{C}$ with no thermal runaway
- Exceeds environmental standards of MIL-S-19500/228
- Ultra fast switching for high efficiency

MECHANICAL DATA

- Case: Molded plastic, DO-15
- Terminals: Axial leads, solderable per MIL-STD-202, Method 208
- Polarity: Band denotes cathode
- Mounting Position: Any
- Weight: 0.015 ounce, 0.4 gram

DO-15

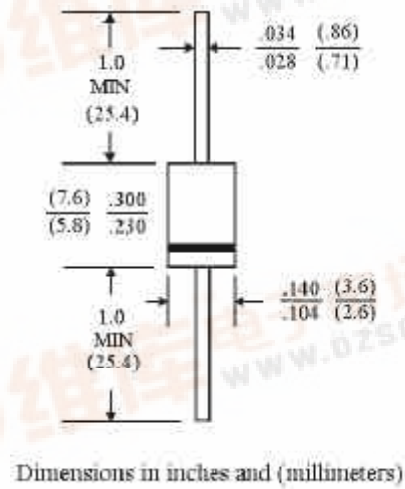

MAXIMUM RATINGS AND ELECTRICAL CHARACTERISTICS

Ratings at 25°C ambient temperature unless otherwise specified.

Single phase, half wave, 60 Hz, resistive or inductive load.

	UF150	UF151	UF152	UF154	UF156	UF158	UF1510	UNITS
Peak Reverse Voltage, Repetitive ; V_{RM}	50	100	200	400	600	800	1000	V
Maximum RMS Voltage	35	70	140	280	420	560	700	V
DC Blocking Voltage; V_R	50	100	200	400	600	800	1000	V
Average Forward Current, I_o @ $T_A=55^\circ\text{C}$ 3.8" lead length, 60Hz, resistive or inductive load	1.5							A
Peak Forward Surge Current I_{FM} (surge) 8.3msec. single half sine-wave superimposed on rated load (JEDEC method)	50							A
Maximum Forward Voltage V_F @ 1.5A, 25°C	1.00		1.10		1.70			V
Maximum Reverse Current, @ Rated $T_J=25^\circ\text{C}$	10.0							μgA
Reverse Voltage $T_J=100^\circ\text{C}$	500							μgA
Typical Junction capacitance (Note 1) C_J	25							pF
Typical Junction Resistance (Note 2) $R_{\theta JKJA}$	50							$^\circ\text{C/W}$
Reverse Recovery Time $I_F=.5A, I_R=1A, I_{rr}=.25A$	50	50	50	50	75	75	75	ns
Operating and Storage Temperature Range	-55 TO +150							$^\circ\text{C}$

NOTES:

- Measured at 1 MHz and applied reverse voltage of 4.0 VDC
- Thermal resistance from junction to ambient and from junction to lead length 0.375"(9.5mm) P.C.B. mounted



RATING AND CHARACTERISTIC CURVES
 UF150 THRU UF1510

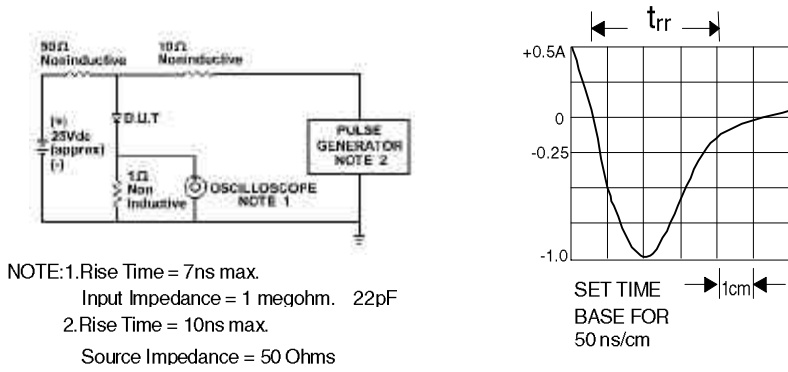

Fig. 1-REVERSE RECOVERY TIME CHARACTERISTIC AND TEST CIRCUIT DIAGRAM

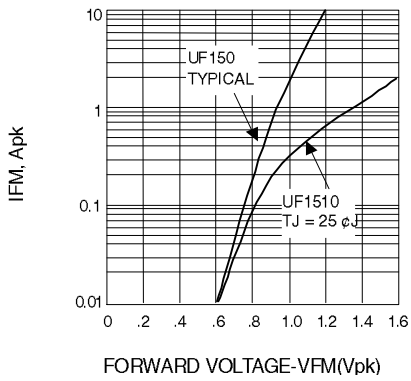

Fig. 2-FORWARD CHARACTERISTICS

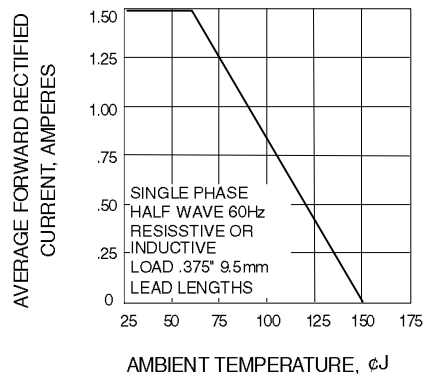

Fig. 3-FORWARD CURRENT DERATING CURVE

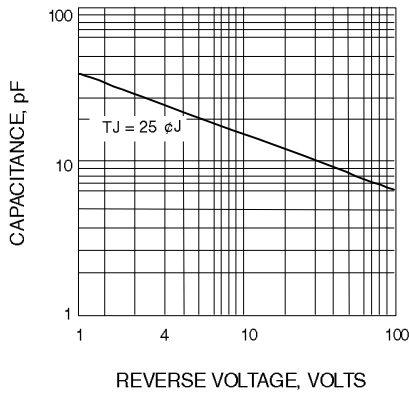

Fig. 4-TYPICAL JUNCTION CAPACITANCE

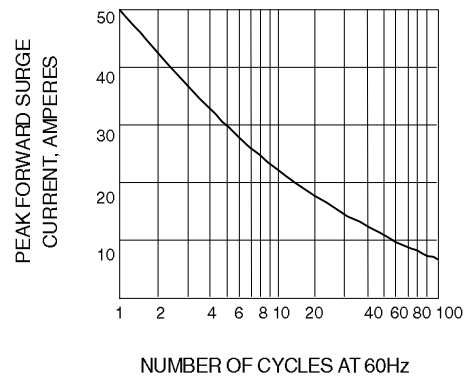

Fig. 5-PEAK FORWARD SURGE CURRENT