

# RF MOSFET Power Transistor, 15W, 28V

## 100 - 500 MHz

UF2815B

V2.00

### Features

- N-Channel Enhancement Mode Device
- DMOS Structure
- Lower Capacitances for Broadband Operation
- Common Source Configuration
- Lower Noise Floor
- 100 MHz to 500 MHz Operation

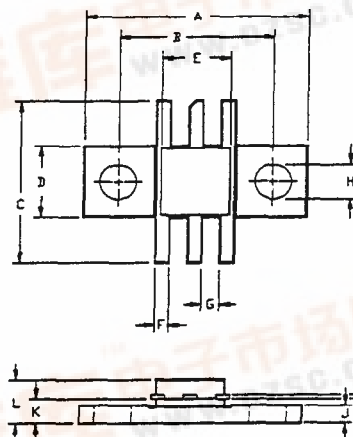

### Absolute Maximum Ratings at 25°C

Parameter	Symbol	Rating	Units
Drain-Source Voltage	$V_{DS}$	65	V
Gate-Source Voltage	$V_{GS}$	20	V
Drain-Source Current	$I_{DS}$	4.2	A
Power Dissipation	$P_D$	48.6	W
Junction Temperature	$T_J$	200	°C
Storage Temperature	$T_{STG}$	-55 to +150	°C
Thermal Resistance	$\theta_{JC}$	3.6	°C/W

LETTER DIM	MILLIMETERS		INCHES	
	MIN	MAX	MIN	MAX
A	20.70	20.96	.815	.825
B	14.35	14.61	.565	.575
C	14.73	15.24	.580	.600
D	6.27	6.53	.247	.257
E	6.22	6.48	.245	.255
F	1.14	1.40	.045	.055
G	1.52	1.78	.060	.070
H	2.92	3.17	.115	.125
J	1.40	1.65	.055	.065
K	2.03	2.39	.080	.094
L	3.66	4.32	.144	.170
M	.10	.15	.004	.006

### Electrical Characteristics at 25°C

Parameter	Symbol	Min	Max	Units	Test Conditions
Drain-Source Breakdown Voltage	$BV_{DSS}$	65	-	V	$V_{GS}=0.0\text{ V}$ , $I_{DS}=6.0\text{ mA}$
Drain-Source Leakage Current	$I_{DSS}$	-	3.0	mA	$V_{DS}=28.0\text{ V}$ , $V_{GS}=0.0\text{ V}$
Gate-Source Leakage Current	$I_{GSS}$	-	3.0	$\mu\text{A}$	$V_{GS}=20\text{ V}$ , $V_{DS}=0.0\text{ V}$
Gate Threshold Voltage	$V_{GS(TH)}$	2.0	6.0	V	$V_{DS}=10.0\text{ V}$ , $I_{DS}=30.0\text{ mA}$
Forward Transconductance	$G_M$	.240	-	S	$V_{DS}=10.0\text{ V}$ , $I_{DS}=300.0\text{ mA}$ , $\Delta V_{GS}=1.0\text{ V}$ , 80 $\mu\text{s}$ Pulse
Input Capacitance	$C_{ISS}$	-	21	pF	$V_{DS}=28.0\text{ V}$ , $F=1.0\text{ MHz}$
Output Capacitance	$C_{OSS}$	-	15	pF	$V_{DS}=28.0\text{ V}$ , $F=1.0\text{ MHz}$
Reverse Capacitance	$C_{RSS}$	-	7.2	pF	$V_{DS}=28.0\text{ V}$ , $F=1.0\text{ MHz}$
Power Gain	$G_P$	10	-	dB	$V_{DD}=28.0\text{ V}$ , $I_{DQ}=150.0\text{ mA}$ , $P_{OUT}=15.0\text{ W}$ , $F=500\text{ MHz}$
Drain Efficiency	$\eta_D$	50	-	%	$V_{DD}=28.0\text{ V}$ , $I_{DQ}=150.0\text{ mA}$ , $P_{OUT}=15.0\text{ W}$ , $F=500\text{ MHz}$
Load Mismatch Tolerance	VSWR-T	-	20:1	-	$V_{DD}=28.0\text{ V}$ , $I_{DQ}=150.0\text{ mA}$ , $P_{OUT}=15.0\text{ W}$ , $F=500\text{ MHz}$

Typical Broadband Performance Curves

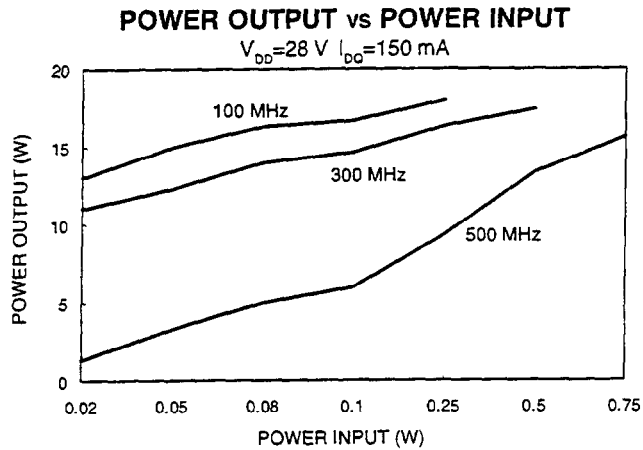
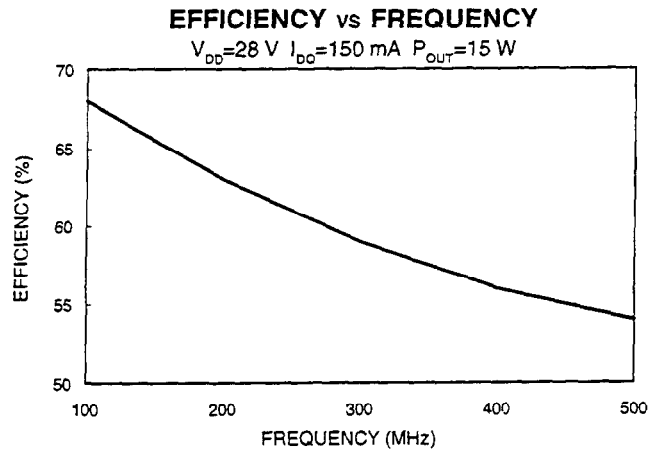
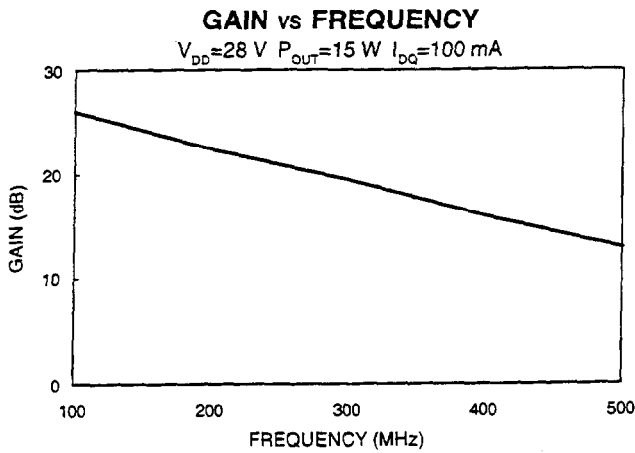
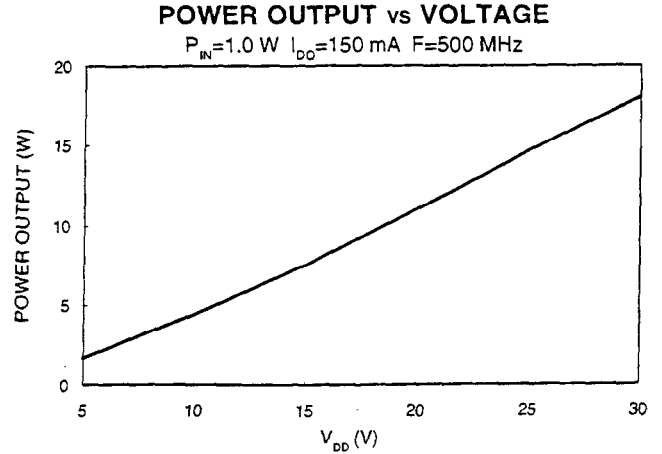
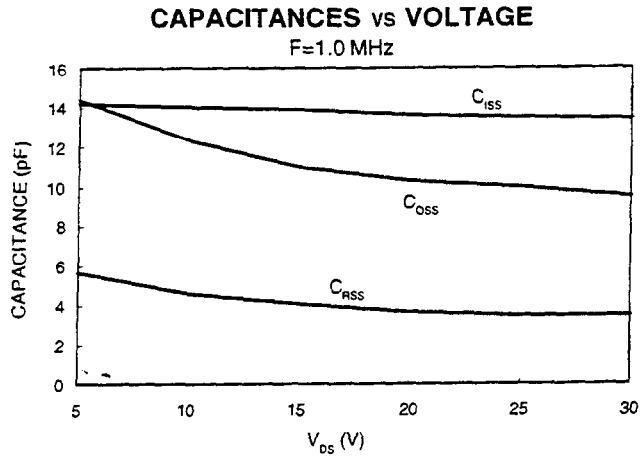

Specifications Subject to Change Without Notice.

M/A-COM, Inc.

North America: Tel. (800) 366-2266  
Fax (800) 618-8883

Asia/Pacific: Tel. +81 (03) 3226-1671  
Fax +81 (03) 3226-1451

Europe: Tel. +44 (1344) 869 595  
Fax +44 (1344) 300 020

Typical Device Impedance

Frequency (MHz)	Z <sub>IN</sub> (OHMS)	Z <sub>LOAD</sub> (OHMS)
100	6.4 - j 25.0	22.0 + j 16.0
300	6.5 - j 12.0	15.0 + j 14.0
500	1.7 - j 10.5	8.0 + j 10.5

V<sub>DD</sub>=28 V, I<sub>DD</sub>=150 mA, P<sub>OUT</sub>=15.0 Watts

Z<sub>IN</sub> is the series equivalent input impedance of the device from gate to source.

Z<sub>LOAD</sub> is the optimum series equivalent load impedance as measured from drain to ground.

RF Test Fixture

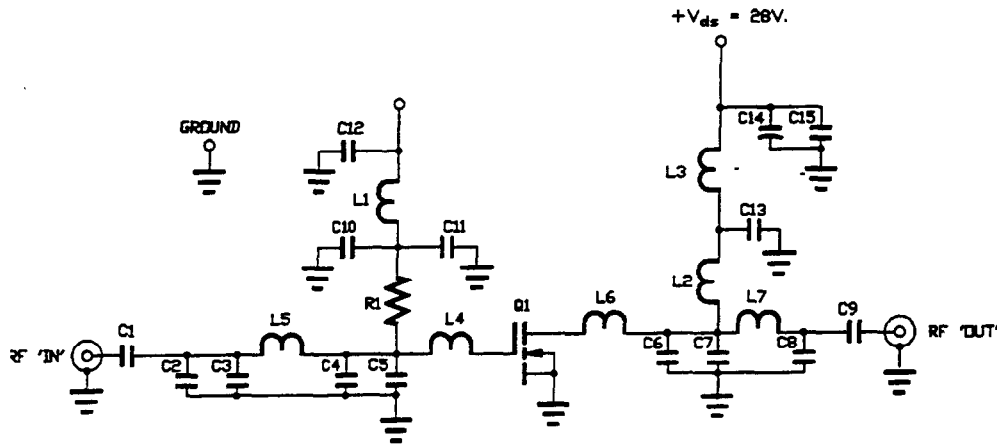

PARTS LIST

- C7 2.0 pf
- C4 3.0pf
- C6 3.6pf
- C5, 8 5.6pf
- C3 9.1pf
- C2 13pf
- C9 270pf
- C1 820pf
- C11, 12, 13, 15 .015uF
- C10 .10uF
- C14 50uF 50V.
- R1 10K OHM
- Q1 UF2815B
- L1, 3 9 TURNS OF NO. 22 AWG
- L2 20 TURNS OF NO. 22 AWG
- L4 .55' OF 50 OHM TRANSMISSION LINE
- L5 .25' OF 50 OHM TRANSMISSION LINE
- L6 1.20' OF 50 OHM TRANSMISSION LINE
- L7 .10' OF 50 OHM TRANSMISSION LINE