



UG12JT, UGF12JT, UGB12JT Series

New Product

Vishay Semiconductors
formerly General Semiconductor

Ultrafast Rectifiers

Reverse Voltage 500 to 600V
Forward Current 12A
Reverse Recovery Time 30ns

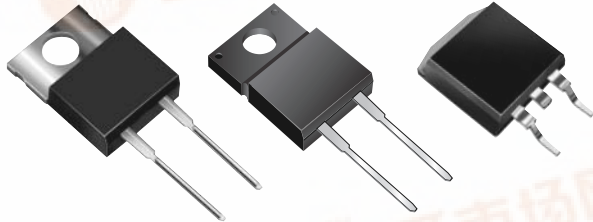

TO-220AC (UG12 Series)

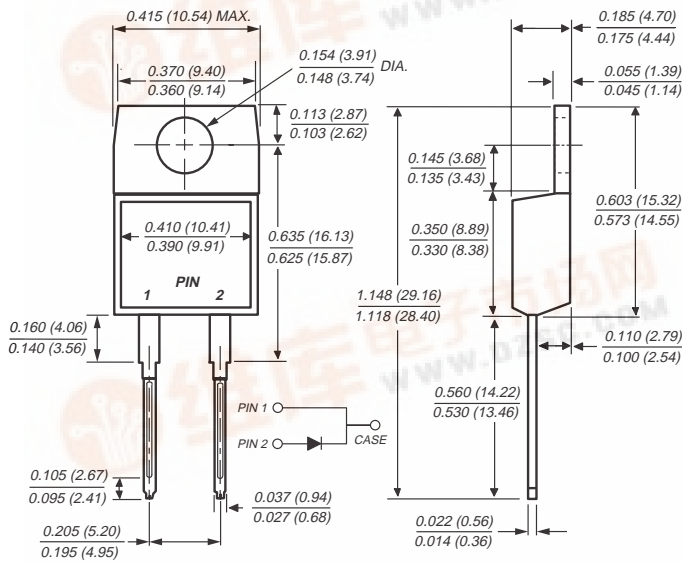

ITO-220AC (UGF12 Series)

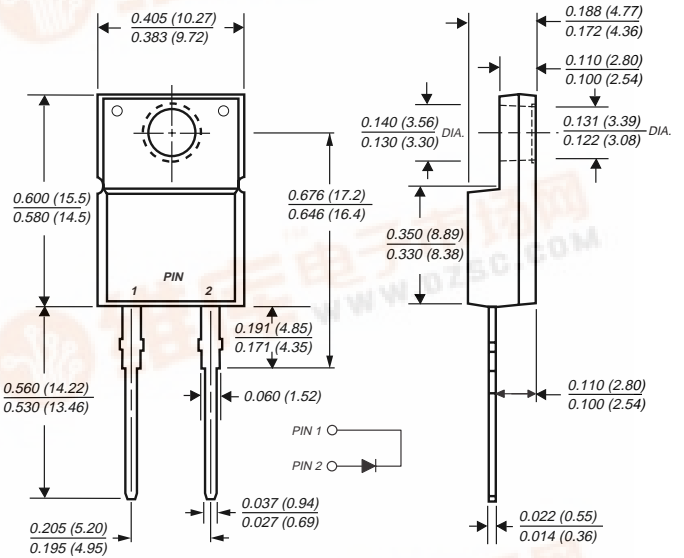

Mounting Pad Layout TO-263AB

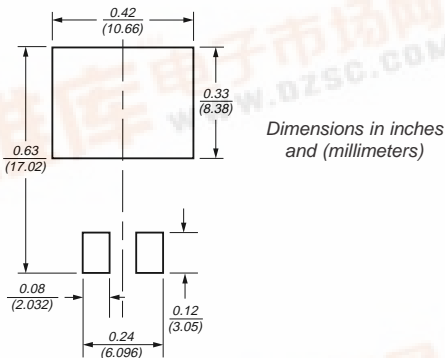

TO-263AB (UGB12 Series)

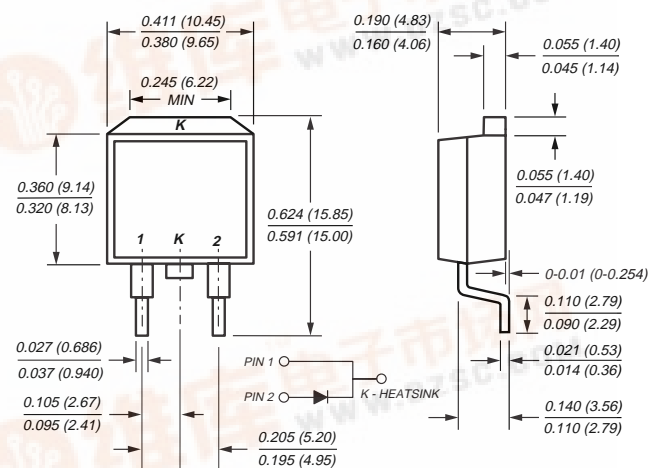

Features

- Plastic package has Underwriters Laboratories Flammability Classification 94V-0
- Ideally suited for freewheeling diode and power factor correction applications
- Soft recovery characteristics
- Excellent high temperature switching
- Optimized to reduce switching losses
- Glass passivated chip junction

Mechanical Data

- Case:** JEDEC TO-220AC, ITO-220AC & TO-263AB molded plastic body
- Terminals:** Plated leads, solderable per MIL-STD-750, Method 2026
- High temperature soldering in accordance with CECC 802 / Reflow guaranteed
- Polarity:** As marked
- Mounting Position:** Any
- Mounting Torque:** 10 in-lbs maximum
- Weight:** 0.08 oz., 2.24 g



UG12JT, UGF12JT, UGB12JT Series



Vishay Semiconductors
formerly General Semiconductor

Maximum Ratings (T_C = 25°C unless otherwise noted)

Parameter	Symbol	UG12HT	UG12JT	Unit
Maximum repetitive peak reverse voltage	V _{RRM}	500	600	V
Maximum working reverse voltage	V _{RWM}	400	480	V
Maximum RMS voltage	V _{RMS}	350	420	V
Maximum DC blocking voltage	V _{DC}	500	600	V
Maximum average forward rectified current	I _{F(AV)}	12		A
Peak forward surge current 8.3ms single half sine-wave superimposed on rated load (JEDEC Method)	I _{FSM}	135		A
Operating junction and storage temperature range	T _J , T _{STG}	-55 to +150		°C
RMS Isolation voltage (UGF types only) from terminals to heatsink with t = 1.0 second, RH ≤ 30%	V _{ISOL}	4500 ⁽¹⁾ 3500 ⁽²⁾ 1500 ⁽³⁾		V

Electrical Characteristics (T_C = 25°C unless otherwise noted)

Parameter	Symbol	UG12HT	UG12JT	Unit
Maximum instantaneous forward voltage ⁽⁴⁾ I _F = 12A, T _J = 25°C I _F = 12A, T _J = 125°C	V _F	1.75 1.50		V
Maximum DC reverse current at V _{RWM} T _J = 25°C T _J = 100°C T _J = 125°C	I _R	30 800 4.0		μA μA mA
Maximum reverse recovery time at I _F = 0.5A, I _R = 1.0A, I _{rr} = 0.25A	t _{rr}	30		ns
Maximum reverse recovery time at I _F = 1.0A, di/dt = 50A/μs, V _R = 30V, I _{rr} = 0.1 I _{RM}	t _{rr}	50		ns
Typical softness factor (t _b /t _a) I _F = 12A, di/dt = 240A/μs, V _R = 400V, I _{rr} = 0.1 I _{RM}	S	0.9		—
Maximum reverse recovery current at I _F = 12A, di/dt = 96A/μs, V _R = 400V, T _C = 125°C	I _{RM}	7.5		A
Peak forward recovery time at I _F = 12A, di/dt = 96A/μs, V _F = 1.1V	t _{fr}	500		ns

Thermal Characteristics (T_C = 25°C unless otherwise noted)

Parameter	Symbol	UG12	UGF12	UGB12	Unit
Typical thermal resistance from junction to case	R _{θJC}	1.73	3.04	1.73	°C/W

- Notes:** (1) Clip mounting (on case), where lead does not overlap heatsink with 0.110" offset
(2) Clip mounting (on case), where leads do overlap heatsink
(3) Screw mounting with 4-40 screw, where washer diameter is ≤ 4.9 mm (0.19")
(4) Pulse test: 300μs pulse width, 1% duty cycle

Ordering Information

Product	Case	Package Code	Package Option
UG12HT & UG12JT	TO-220AC	45	Anti-Static tube, 50/tube, 2K/carton
UGF12HT & UGF12JT	ITO-220AC	45	Anti-Static tube, 50/tube, 2K/carton
UGB12HT & UGB12JT	TO-263AB	31	13" reel, 800/reel, 4.8K/carton
		45	Anti-Static tube, 50/tube, 2K/carton
		81	Anti-Static 13" reel, 800/reel, 4.8K/carton



UG12JT, UGF12JT, UGB12JT Series

Vishay Semiconductors
formerly General Semiconductor

Ratings and Characteristic Curves (T_A = 25°C unless otherwise noted)

Fig. 1 – Forward Current Derating Curve

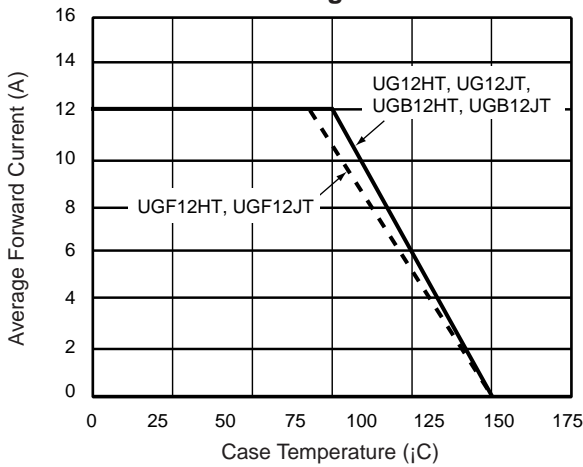

Fig. 2 – Maximum Non-Repetitive Peak Forward Surge Current

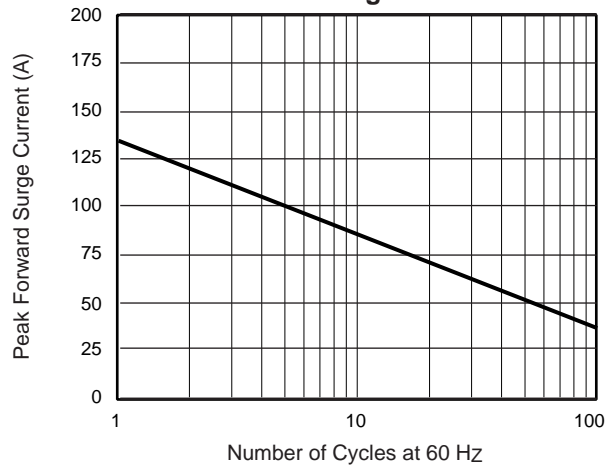

Fig. 3 – Typical Instantaneous Forward Characteristics Per Leg

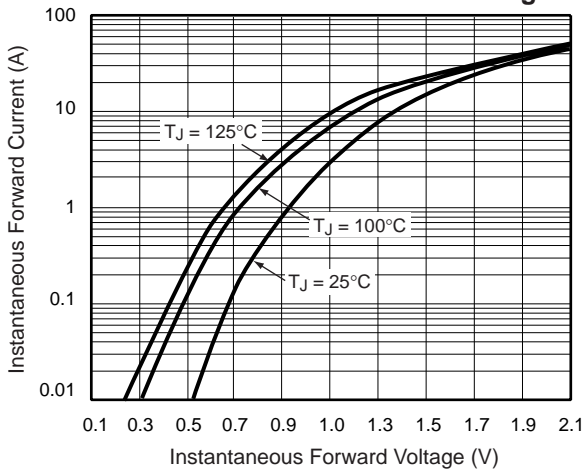

Fig. 4 – Typical Reverse Leakage Characteristics Per Leg

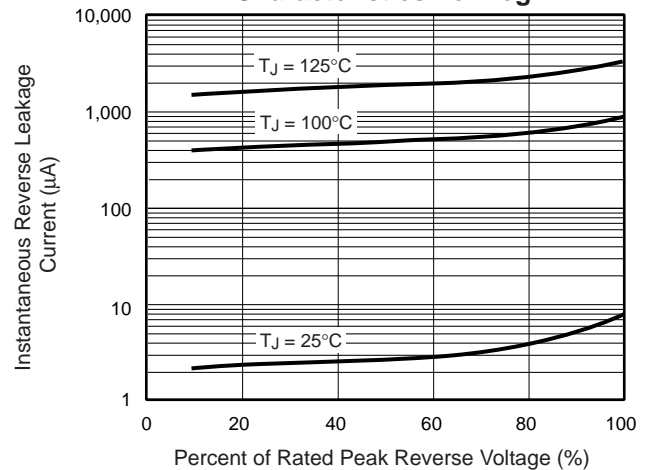

Fig. 5 – Typical Junction Capacitance Per Leg

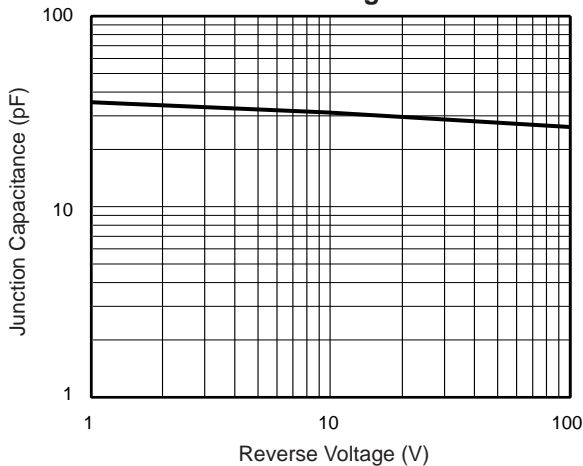

Fig. 6 – Reverse Switching Characteristics Per Leg

