

6427525 N E C ELECTRONICS INC 05E 22829 D  
**BIPOLAR ANALOG INTEGRATED CIRCUIT**  
 **$\mu$ PC1270H**

T-74-05-01  
**30-50 W POWER AMPLIFIER DRIVER**

**DESCRIPTION**

$\mu$ PC1270H is designed for use with a Hi-Fi power amplifier driver. It is composed of a differential amplifier, a predriver, a driver and protection circuit. It is in a 12 pin small power SIP. (Single In Line)

**FEATURES**

- Excellent Low Distortion.  
 0.002 % TYP. ( $V_{CC} = \pm 36$  V,  $f = 1$  kHz,  $A_v = 30$  dB,  $P_O = 30$  W,  $R_L = 8$  Ohms)  
 0.006 % TYP. ( $V_{CC} = \pm 36$  V,  $f = 20$  kHz,  $A_v = 30$  dB,  $P_O = 30$  W,  $R_L = 8$  Ohms)
- Wide Frequency Band.  
 900 kHz TYP. (-3 dB)
- Wide Power Band Width.  
 90 kHz TYP. ( $P_O = 25$  W, T.H.D. = 0.1 %)
- Excellent Low POP ON/OFF Noise.

**BLOCK DIAGRAM**

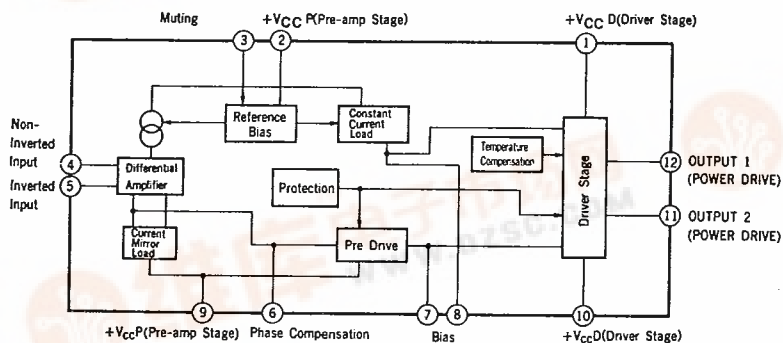

**NOTE:** The protection circuit is for this IC and cannot protect external Power Transistors. Thus, design a  $P_O$  Tr protection circuit besides.



**$\mu$ PC1270H**

6427525 N E C ELECTRONICS INC

05E 22830 D

T-74-05-01

**ABSOLUTE MAXIMUM RATINGS ( $T_a = 25^\circ\text{C}$ )**

Supply Voltage (Quiescent)	$V_{CC1}$	$\pm 50$	V
Supply Voltage (Operational)	$V_{CC2}$	$\pm 45$	V
Quiescent Circuit Current	$I_{CC}$ (peak)	200	mA
Allowable Package Dissipation	$P_D$	4.1	W
Operational Temperature	$T_{opt}$	-20 to +75	$^\circ\text{C}$
Storage Temperature	$T_{stg}$	-40 to +150	$^\circ\text{C}$

**RECOMMENDED OPERATING CONDITION**

Supply Voltage (Operational)	$V_{CC} = \pm 18$ to $\pm 36$ V at MAX. Power Output
Input Bias Resistance	$R_{IN} = 1$ to 50 to 100 kohms
Power Transistor $h_{FE}$	$h_{FE} = 50$ at MAX. Power Output
Closed Loop Voltage Gain	$A_v = 26$ to 30 dB

**ELECTRICAL CHARACTERISTICS ( $V_{CC} = \pm 36$  V,  $A_v = 30$  dB, Use Standard Test Circuit,  $T_a = 25^\circ\text{C}$ )**

CHARACTERISTIC	SYMBOL	MIN.	TYP.	MAX.	UNIT	CONDITION
Output Offset Voltage	$V_{OFF}$		$\pm 5$	$\pm 100$	mV	SEE TEST CIRCUIT 1
Quiescent Circuit Current	$I_{CC}$		20	40	mA	$V_{IN} = 0$
Maximum Output Voltage	$V_{OM}$	20	23		V	T.H.D. = 0.05 % $f = 20$ to $20$ kHz
Open Loop Voltage Gain	$A_{vo}$	80	95		dB	$V_o = 1.5$ V, $f = 1$ kHz
Output Noise Voltage	$V_{NO}$		0.07	0.14	mV	$R_G = 10$ kohms
Power Band Width	P.B.W.		900		kHz	$V_o = 1.5$ V, -3dB
Supply Voltage Rejection Ratio	S.V.R.	55	70		dB	$R_G = 2$ kohms, $f = 100$ Hz
Output Offset Voltage (Mute)	$V_{OFF}(Mute)$			$\pm 50$	mV	$V_{CC} = \pm 50$ V, TEST CIRCUIT 7

6427525 N E C ELECTRONICS INC

$\mu$ PC1270H  
05E 22831 D

T-74-05-01

12 PIN SIP (Unit : mm)

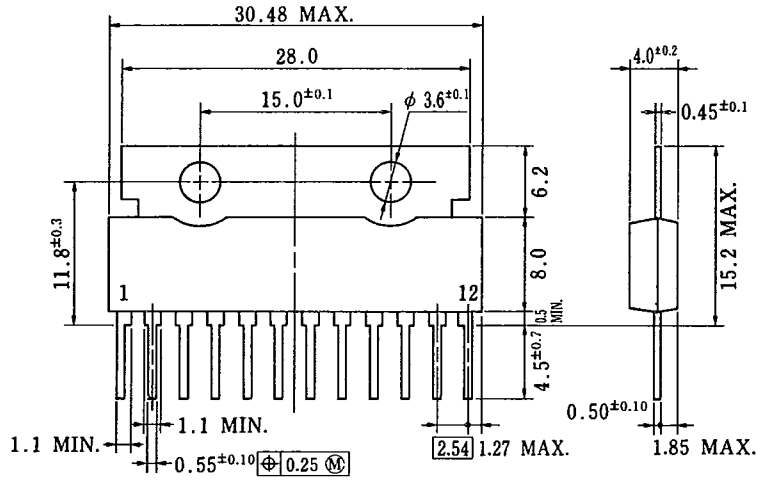

P12HP-254B1

PIN CONNECTION DIAGRAM

PIN NO.	PIN CONNECTION
1	+V <sub>CCD</sub> (for Driver)
2	+V <sub>CCP</sub> (for Preamp)
3	MUTING
4	INPUT
5	NFB
6	PHASE COMP
7	BIAS
8	BIAS
9	-V <sub>CCP</sub> (for Preamp)
10	-V <sub>CCD</sub> (for Driver)
11	LOWER OUTPUT
12	UPPER OUTPUT

5

$\mu$ PC1270H  
6427525 N E C ELECTRONICS INC

05E 22832 D

T-74-05-01

TEST CIRCUIT 1 ( $V_{OFF}$ )

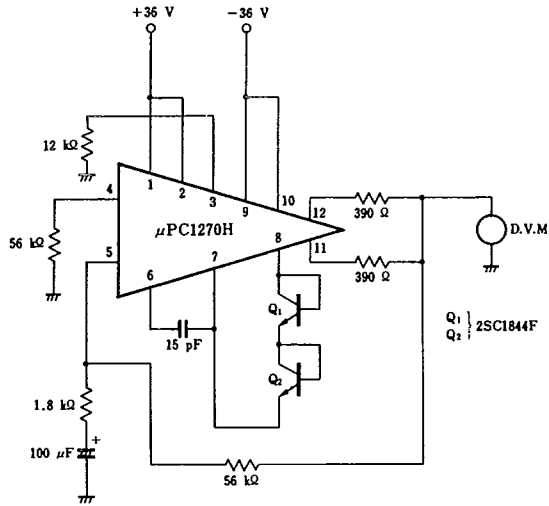

TEST CIRCUIT 2 ( $I_{CC}$ )

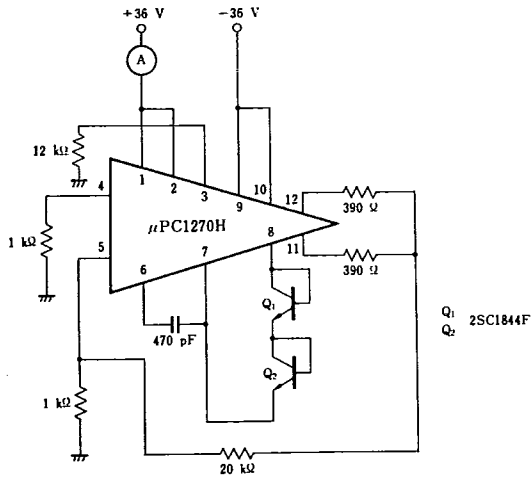

6427525 N E C ELECTRONICS INC

$\mu$ PC1270H  
05E 22833 D

TEST CIRCUIT 3 ( $V_{om}$ )

T-74-05-01

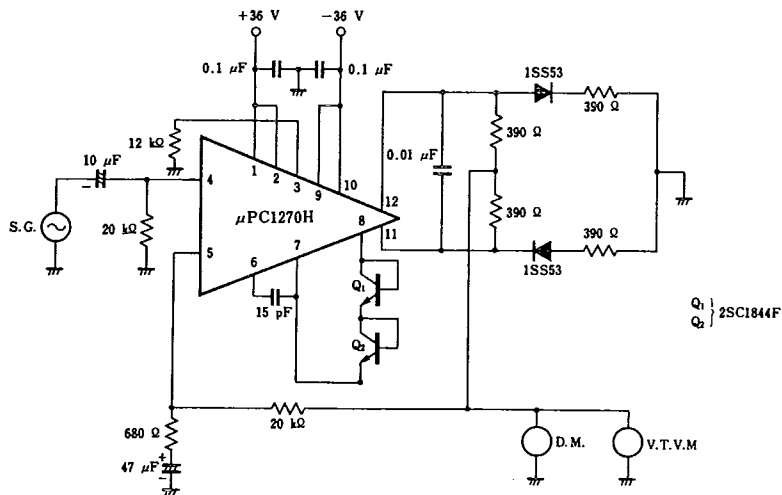

TEST CIRCUIT 4 ( $A_{vo}$ )

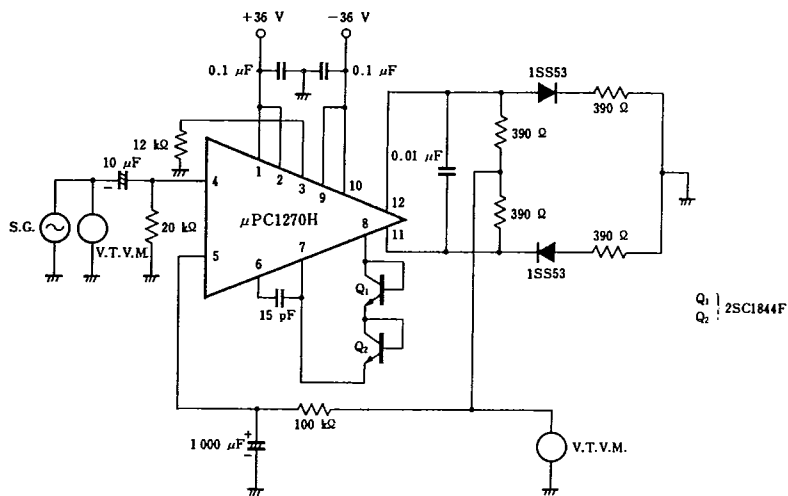

5

**μPC1270H**  
6427525 N E C ELECTRONICS INC

05E 22834 D

TEST CIRCUIT 5 (V<sub>NO</sub>)

T-74-05-01

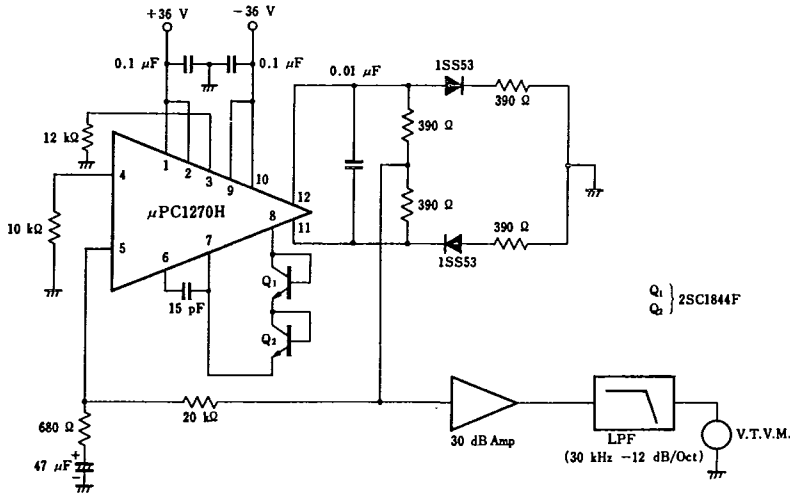

TEST CIRCUIT 6 (S.V.R.)

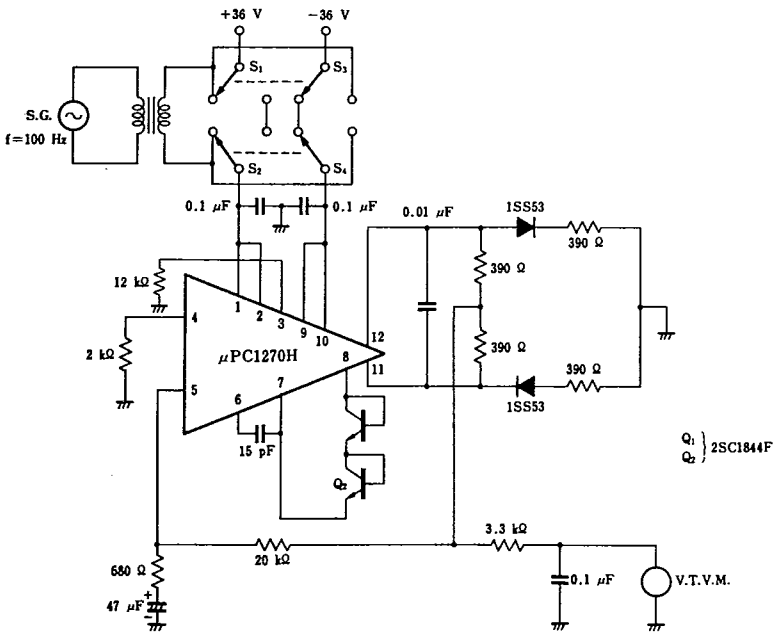

6427525 N E C ELECTRONICS INC

$\mu$ PC1270H  
05E 22835 D

TEST CIRCUIT 7 (V<sub>OFF</sub>(MUTE))

T-74-05-01

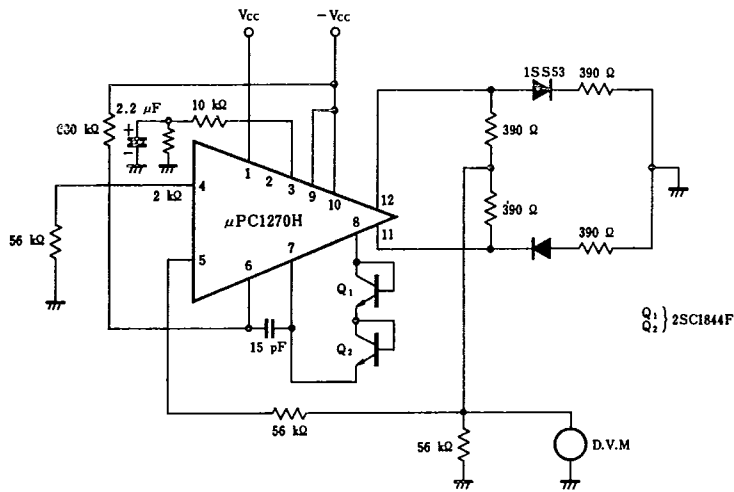

**μPC1270H**  
**6427525 N E C ELECTRONICS INC**

05E 22836 D

T-74-05-01

TYPICAL CHARACTERISTICS (T<sub>a</sub> = 25°C)

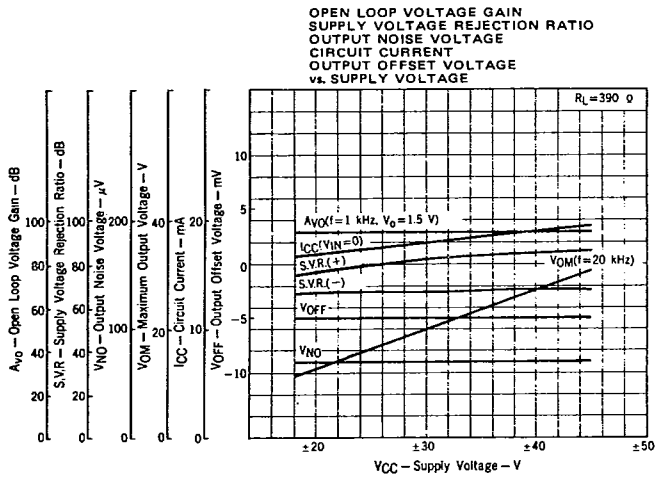
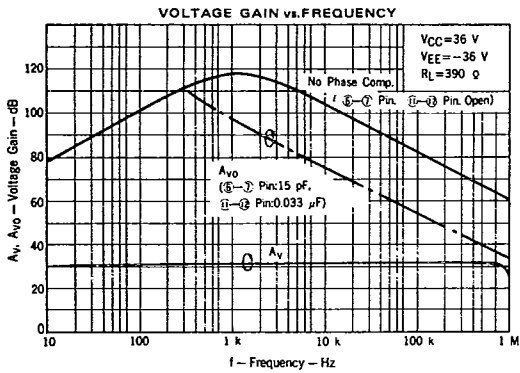
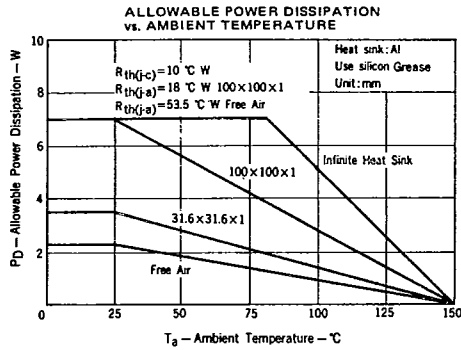



T-74-05-01

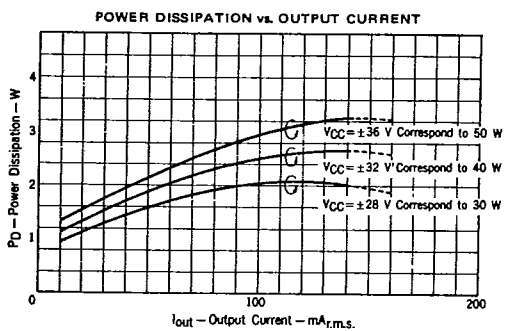
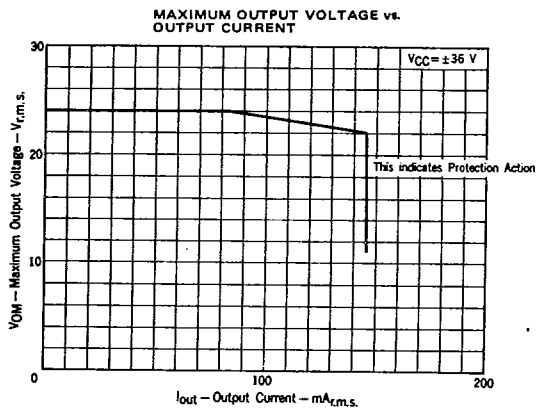
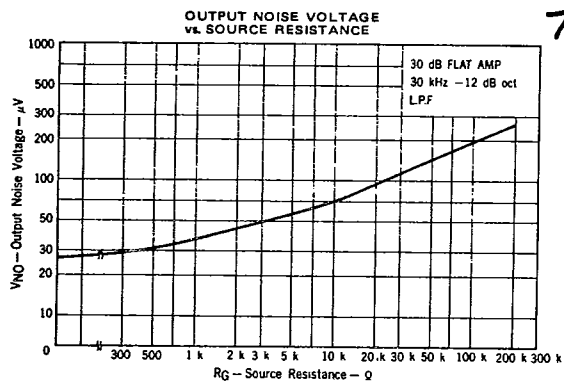

5

**μPC1270H**  
6427525 N E C ELECTRONICS INC

05E 22838 D

T-74-05-01

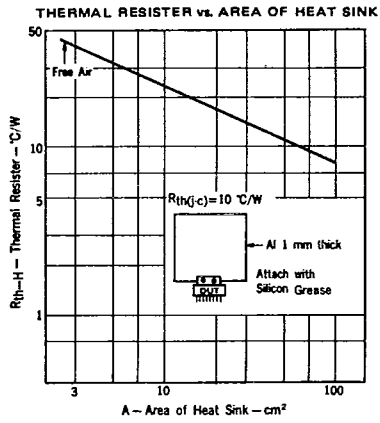

**APPLICATION CIRCUIT-1**

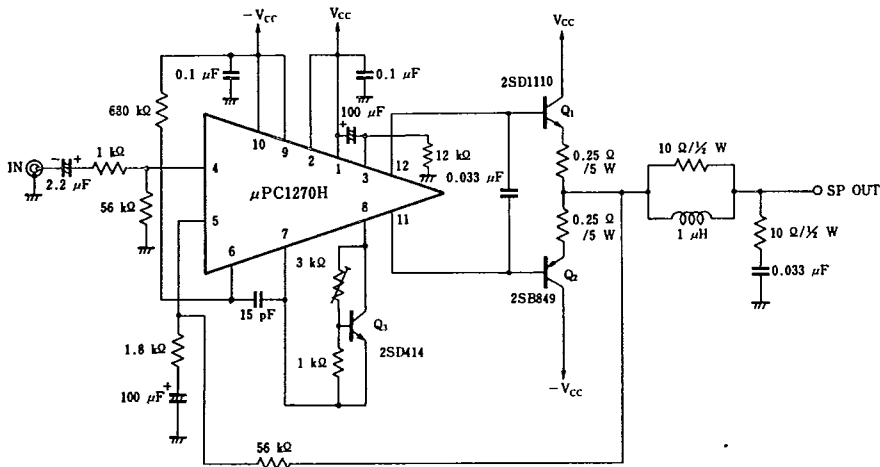

6427525 N E C ELECTRONICS INC

$\mu$ PC1270H  
05E 22839 D

T-74-05-01

$\mu$ PC1270H APPLICATION CIRCUIT-2 (no Relay)

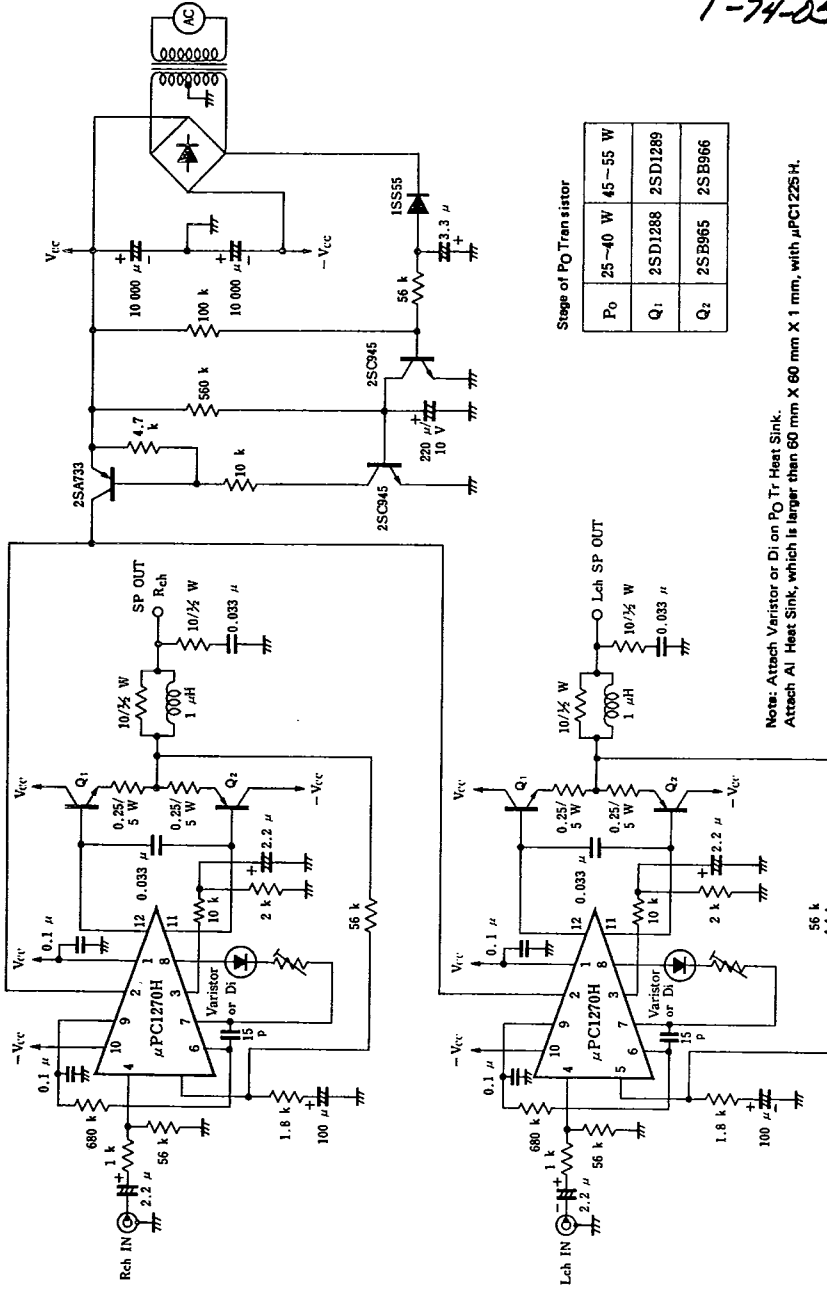

Stage of Po Transistor

P <sub>0</sub>	25-40 W	45-55 W
Q <sub>1</sub>	2SD1288	2SD1289
Q <sub>2</sub>	2SB965	2SB966

Note: Attach Varistor or Di on P<sub>0</sub> Tr Heat Sink.  
Attach Al Heat Sink, which is larger than 60 mm X 1 mm X 60 mm X 1 mm, with  $\mu$ PC1225H.

$\mu$ PC1270H  
6427525 N E C ELECTRONICS INC

05E 22840 D

T-74-05-01

$\mu$ PC1270H/ $\mu$ PC1237H/MP-80 EVALUATION CIRCUIT

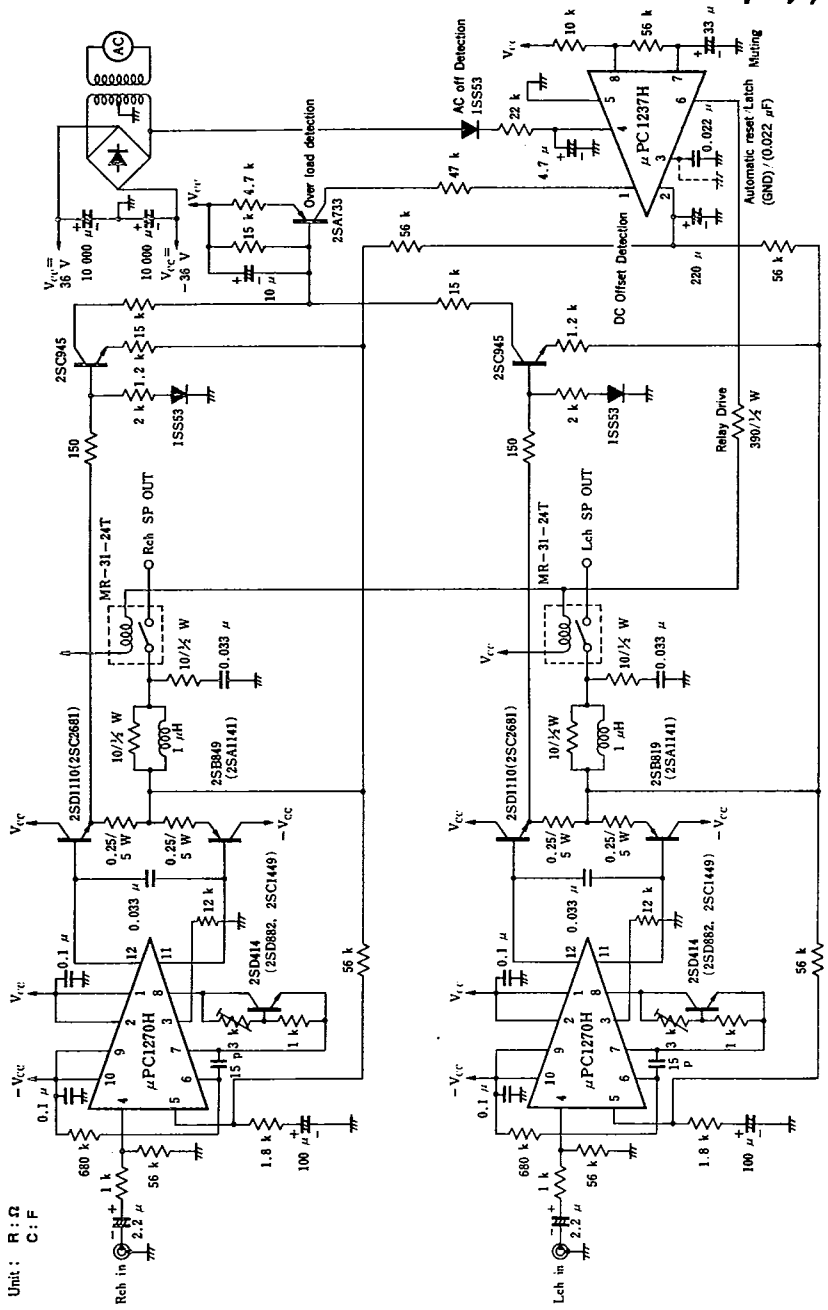

Note: Attach 25D414 on PO Tr Heat Sink.  
Attach A1 Heat Sink, which is larger than 60 mm X 60 mm X 1 mm, with  $\mu$ PC1270H.

Note:

- #1 These terminals are for 3-terminals regulators ( $\mu$ PC7818H,  $\mu$ PC7918H) as a  $\mu$ PC1224H power supply.
- #2 These terminals are for JP—lines to a temperature Compensation transistor (2SD414 or others).
- #3 Use 0.02  $\mu$ F capacitance in case of using  $\mu$ PC1237H at latching function, while connect each other at automatic resetting.
- #4 This capacitance is for preventing POP ON/OFF noise.
- #5 These terminals are for JP—lines in case of using the same power supply ( $\mu$ PC1237H and Power Amplifier)
- #6 These terminals are for JP—lines in case of using the same power supply ( $\mu$ PC1270H and Power Tr)
- #7 This terminal is for AC-OFF Detection. Thus, use 8.2 k ohms instead of 22 k ohms, neglect 1SS53 and connect these 1SS53's terminals and neglect 4.7  $\mu$ F in case of using DC power supply.
- #8 These capacitance are for preventing a parasitic oscillation. Use a 0.1  $\mu$ F.
- #9 These trimmers are for adjusting an idling current. Recommend Neo-Pot PSS1 Series.
- #10 These capacitance are for the 3-terminals regulator input.
- #11 Design of 1  $\mu$ H (example)
- #12 This indicates a copper board pattern

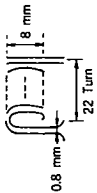

This is the evaluation circuit. Thus, it is not for a mass production considered about component deviation and the temperature characteristic.

$\mu$ PC1270H/ $\mu$ PC1224H/MP-80 (2SC849, 2SD1110 or 2SA2681, 2SC1141) Evaluation Circuit Board Component Arrangement

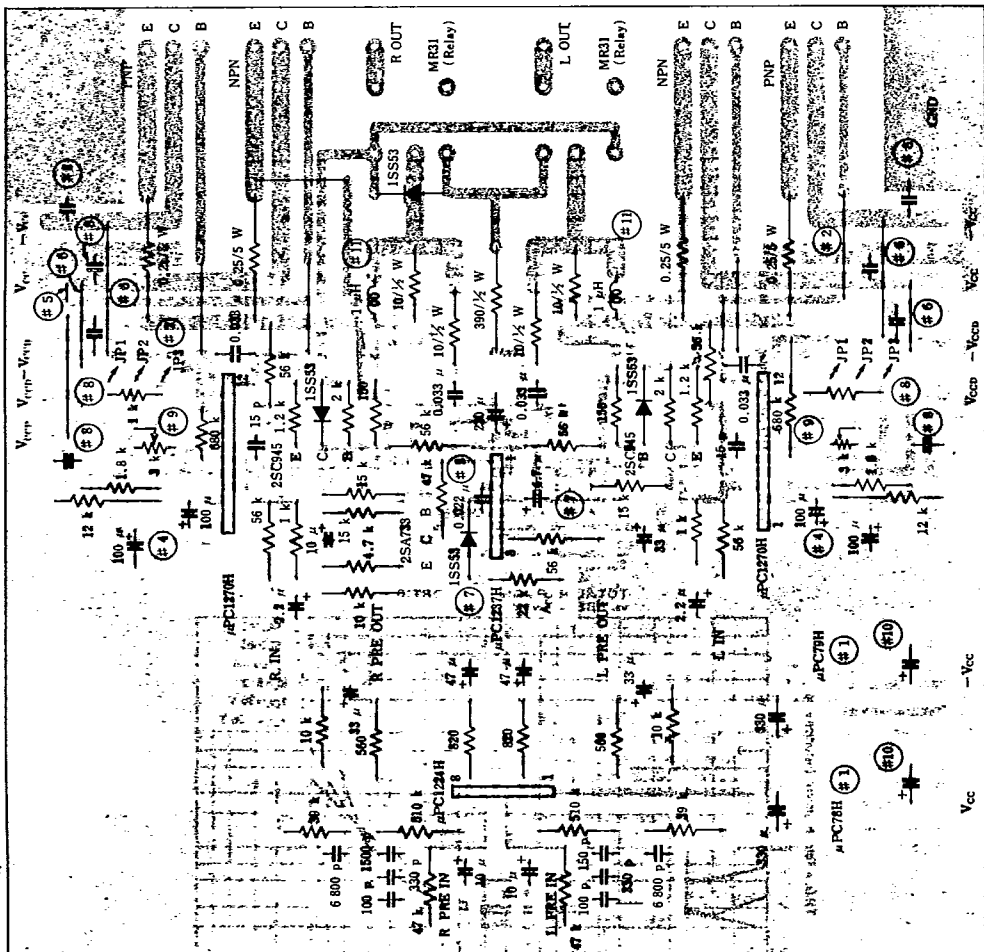

5

$\mu$ PC1270H  
6427525 N E C ELECTRONICS INC

05E 22842 D

T-74-05-01

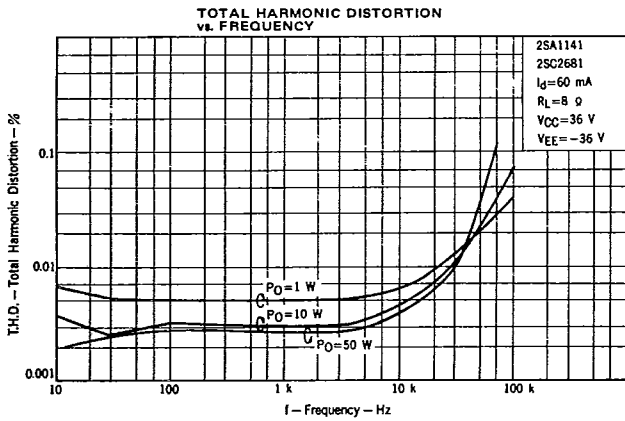
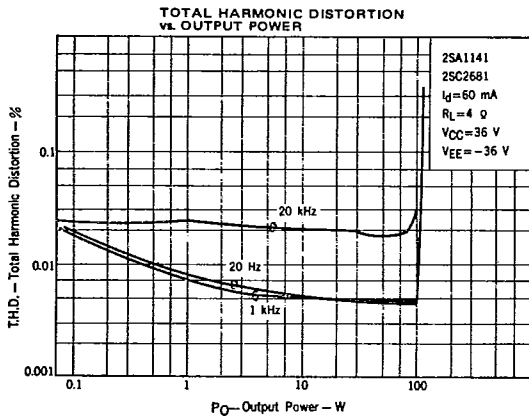
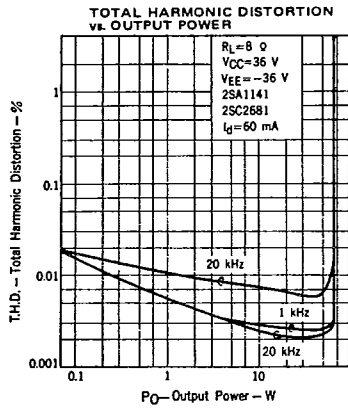

T-74-05-01

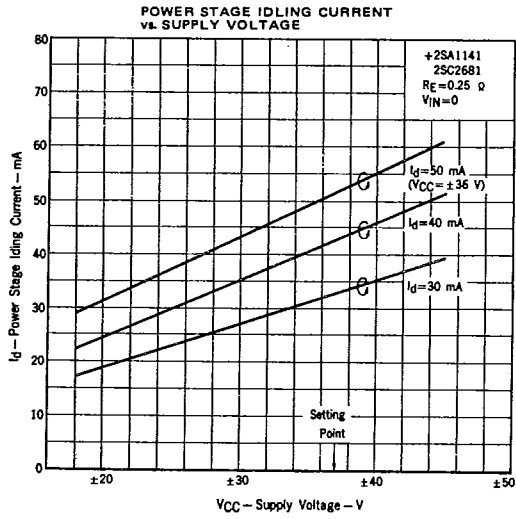
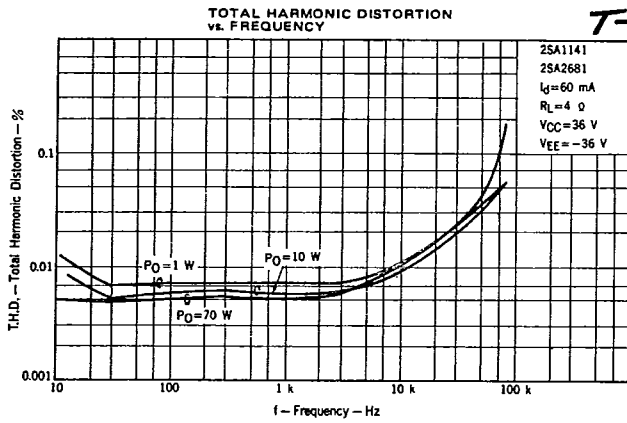

$\mu$ PC1270H  
6427525 N E C ELECTRONICS INC

05E 22844 D

T-74-05-01

POP NOISE (Sw on)

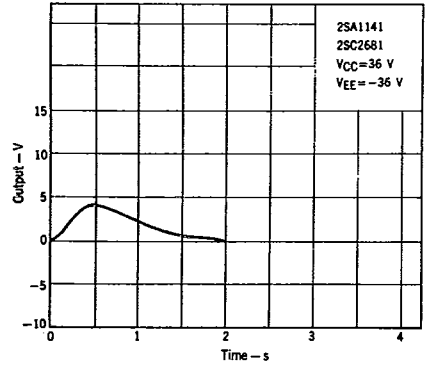

POP NOISE (Sw off)

