



BIPOLAR ANALOG INTEGRATED CIRCUITS

μ PC1490, μ PC1491

REMOTE CONTROL PREAMPLIFIER

DESCRIPTION

The μ PC1490 and μ PC1491 are bipolar integrated circuit intended for application in infrared remote controls. The μ PC1490 and μ PC1491 contain a high-gain amplifier, a limiter amplifier, a band-pass filter, a detector and a pulse shaper.

The μ PC1490's output polarity is active "Low" and the μ PC1491's output polarity is active "High".

FEATURES

- On-chip band-pass filter: Frequency range 30 to 60 kHz.
- High gain pre-amplifier: 86 dB TYP.
- Detector for PCM demodulation
- Low current consumption
- Minimum external components
- Open collector output: Easy interface to all microcomputer remote control decoders.
TTL and CMOS compatible output.

ORDERING INFORMATION

Part Number	Package	Output Data
μ PC1490HA	8 pin PLASTIC slim SIP	active "L"
μ PC1490G	8 pin PLASTIC SOP	
μ PC1491HA	8 pin PLASTIC slim SIP	active "H"
μ PC1491G	8 pin PLASTIC SOP	

BLOCK DIAGRAM

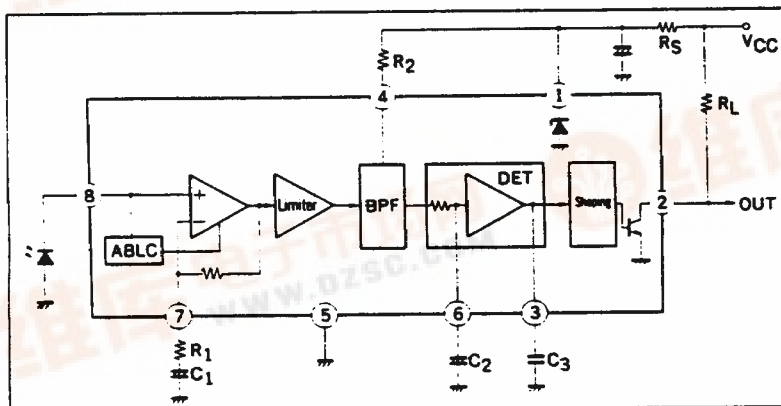

NEC cannot assume any responsibility for any circuits shown or represent that they are free from patent infringement.



ABSOLUTE MAXIMUM RATINGS (T_a = 25 °C)

Supply Voltage	V _{CC}	5.6*	V	*R _s = 0 Ω
Output Voltage	V _{out}	15	V	
Input Voltage	V _{IN}	5.0	V _{p-p}	
Supply Current	I _{CC}	6.0	mA	
Output Current	I _{OUT}	2.5	mA	
Power Dissipation	P _D	270	mW	
Operating Temperature	T _{opt}	-20 to +75	°C	
Storage Temperature	T _{stg}	-40 to +125	°C	

RECOMMENDED OPERATING CONDITIONS

CHARACTERISTIC	SYMBOL	MIN.	TYP.	MAX.	UNIT	NOTE
Power Supply Voltage	V _{CC}	4.5	5.0	5.5	V	R _s = 0 Ω
Power Supply Voltage	V _{CC'}	11	12	13	V	R _s = 1.5 kΩ
Operating Frequency	f ₀	30		60	kHz	

ELECTRICAL CHARACTERISTICS (T_a = 25 °C, V_{CC} = 5.0 V)

CHARACTERISTIC	SYMBOL	MIN.	TYP.	MAX.	UNIT	ON-SW	TEST PIN	TEST CONDITIONS
Power Supply Current	I _{CC}		1.6	2.5	mA	1, 7	V _{CC}	μPC1490
			1.9	2.8	mA	1, 7	V _{CC}	μPC1491
Input Pin Voltage 1	V _{IN1}	2.0	2.5	3.1	V	7	8	
Input Pin Voltage 2	V _{IN2}	0.6	0.9	1.7	V	2, 3, 7	8	I ₁ = -100 μA
Voltage Gain	A _v	74	86	89	dB	2, 4, 6	6	38 kHz CW, v _i = 30 μV _{p-p}
Frequency Response	A _{vQ}	4.0	10		dB	2, 4, 6	6	28, 35, 41, 48 kHz CW v _i = 30 μV _{p-p} , Note 1
Input Impedance	r _{in}	27	40	55	kΩ	2, 7	8	38 kHz CW, Note 2 v _i = 0.2 V _{p-p}
Output Pulse Width 1	tpW1	440		770	μs	2, 4, 7, 9	2	38 kHz Burst, v _i = 60 μV _{p-p} , Note 3
Output Pulse Width 2	tpW2	440		770	μs	2, 4, 7, 9	2	V _{CC} = 4 V, 38 kHz Burst, v _i = 50 mV _{p-p} , Note 3
Output Voltage	V _{OL}		0.2	0.4	V	1, 5, 9	2	μPC1490HA: E ₁ = 1.0 V μPC1491HA: E ₁ = 2.5 V
Output Leak Current	I _{OH}			2.0	μA	1, 5, 8	2	E ₂ = 15 V, μPC1490: E ₁ = 2.5 V μPC1491: E ₁ = 1.0 V

Note 1: Voltage gain difference
 $A_{vQ} = A_v(35 \text{ kHz}) - A_v(28 \text{ kHz})$
 $A_{vQ} = A_v(41 \text{ kHz}) - A_v(48 \text{ kHz})$

Note 2: $r_{in} = \frac{47}{v_i/v_x - 1}$ (kΩ), v_x: Input voltage, v_i: SG output voltage

Note 3: Input burst

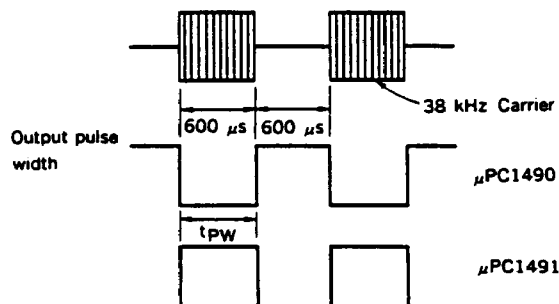

PIN FUNCTION

- **Power Supply (V_{CC} :Pin1, GND:Pin5)**

Normal operation voltage is $5\text{ V} \pm 10\%$.
In case of using a $12\text{ V} \pm 1\text{ V}$ power supply, insert a $1.5\text{ k}\Omega \pm 5\%$ series resistor between V_{CC} and power supply.
The internal zener diode regulates the V_{CC} voltage to about 5.9 V. Do not supply the circuit current more than 6.0 mA.
- **Input (IN^+ :Pin8, IN^- :Pin7)**

The input impedance is $40\text{ k}\Omega$ TYP.
The infrared receiver diode can be directly connected to the input.
This input has ABLC (Automatic Bias Level Control) circuit and it keeps the amplifier properly biased from IR inputs.
The voltage gain of the input amplifier is determined by the external impedance R_1 and C_1 at Pin7.
- **Band-pass Filter Center Frequency Adjust (f_0 :Pin4)**

The tuning frequency of band-pass filter is determined by internal capacitors and the external resistor R_2 . The tuning frequency ranges from 30 kHz to 60 kHz.
- **Detector Capacitor (C_D :Pin6)**

The detector consists of a filter and a comparator. The external capacitor C_2 at Pin 6 is used for the filter.
- **Integral Capacitor (C_I :Pin3)**

The external capacitor C_3 at Pin 3 filters the carrier from the pulses.
- **Output (OUT:Pin2)**

The output is open collector transistor, can directly drives a TTL or a CMOS. And the break-down voltage of the output is over 15 V, so it is easy to interface to all microcomputer remote control decoders.
The μ PC1490 is active "Low" output. The μ PC1491 is active "High" output.

TYPICAL CHARACTERISTICS ($T_a = 25^\circ\text{C}$)

$I_{CC} - V_{CC}$ CHARACTERISTICS

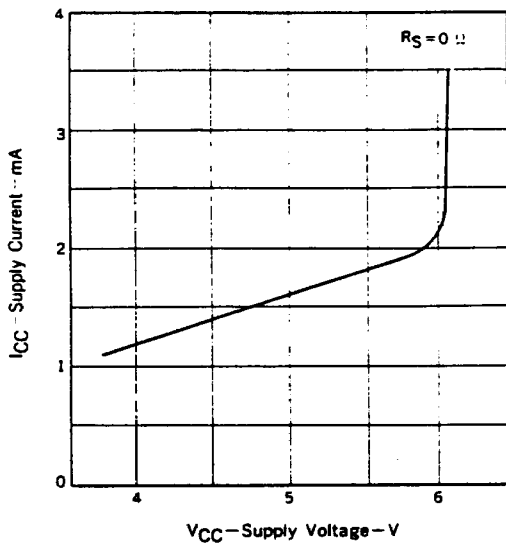

$f_0 - R_2$ CHARACTERISTICS

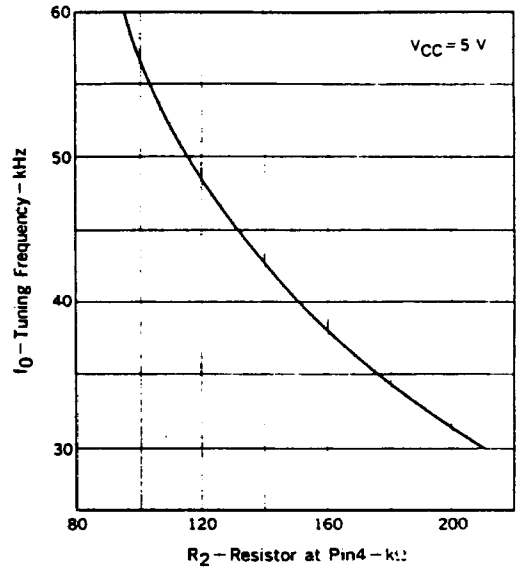

$A_v - f_{in}$ CHARACTERISTICS

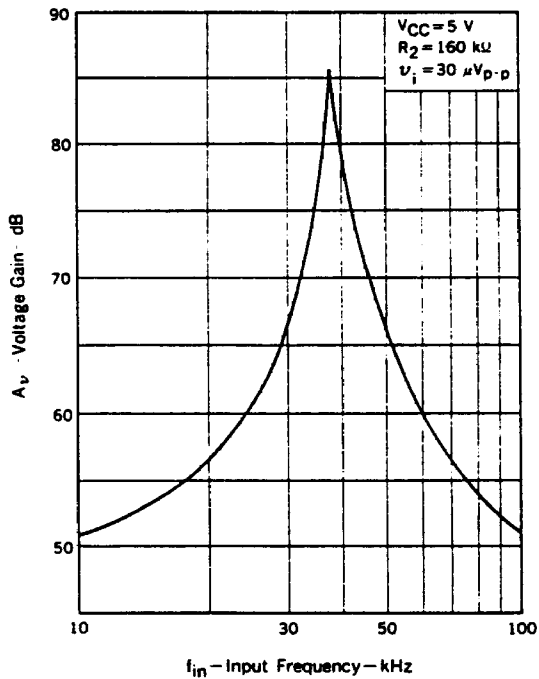

$A_v - R_1$ CHARACTERISTICS

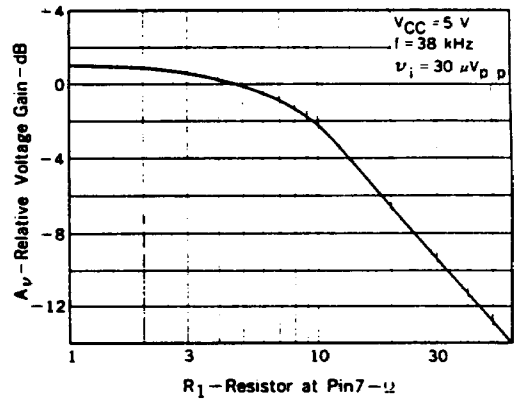

APPLICATION

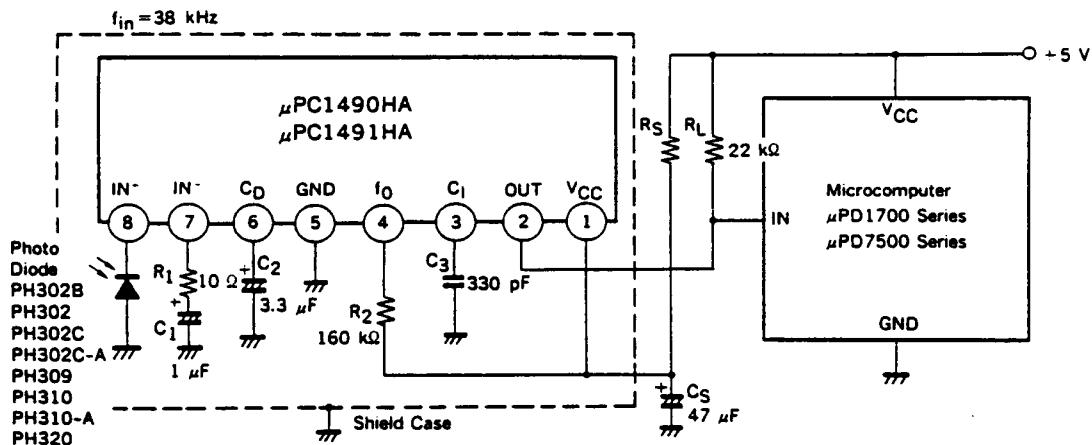

8 PIN PLASTIC SLIM SIP

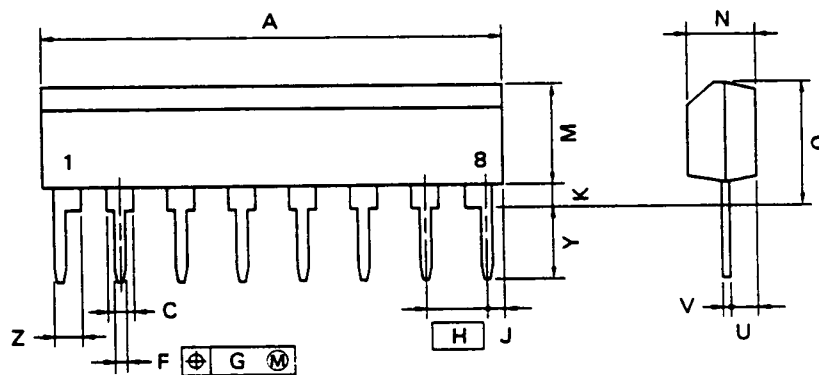

NOTE

Each lead centerline is located within 0.25 mm (0.01 inch) of its true position (T.P.) at maximum material condition.

PSHA-2548

ITEM	MILLIMETERS	INCHES
A	20.32 MAX.	0.8 MAX.
C	1.1 MIN.	0.043 MIN.
F	0.5 ^{+0.1}	0.02 ^{+0.004}
G	0.25	0.01
H	2.54	0.1
J	1.27 MAX.	0.05 MAX.
K	0.51 MIN.	0.02 MIN.
M	5.08 MAX.	0.2 MAX.
N	2.8 ^{+0.2}	0.11 ^{+0.008}
Q	5.75 MAX.	0.227 MAX.
U	1.5 MAX.	0.059 MAX.
V	0.25 ^{+0.02}	0.01 ^{+0.001}
Y	3.2 ^{+0.5}	0.126 ^{+0.02}
Z	1.1 MIN.	0.043 MIN.

8PIN PLASTIC MINI FLAT (225 mil)

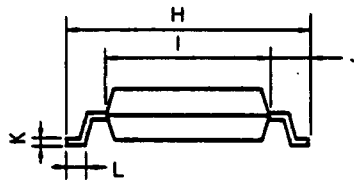
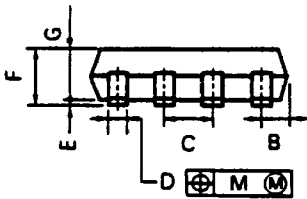
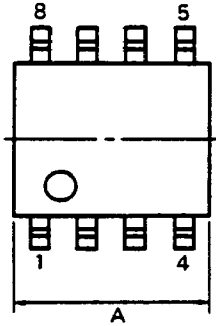

S8GM-50-225B

NOTE

Each lead centerline is located within 0.12 mm (0.005 inch) of its true position (T.P.) at maximum material condition.

ITEM	MILLIMETERS	INCHES
A	5.70 MAX.	0.225 MAX.
B	0.94 MAX.	0.037 MAX.
C	1.27 (T.P.)	0.050 (T.P.)
D	0.40 $^{+0.02}$	0.016 $^{+0.001}$
E	0.1 $^{+0.1}$	0.004 $^{+0.004}$
F	1.8 MAX.	0.071 MAX.
G	1.49	0.059
H	6.5 $^{+0.3}$	0.256 $^{+0.012}$
I	4.4	0.173
J	1.1	0.043
K	0.15 $^{+0.02}$	0.006 $^{+0.001}$
L	0.6 $^{+0.2}$	0.024 $^{+0.008}$
M	0.12	0.005