

# NEC

## GaAs MMIC DBS 4X2 IF SWITCH UPG183GR

### FEATURES

- FOUR INDEPENDENT IF CHANNELS
- INTEGRAL SWITCHING TO CHANNEL INPUT TO EITHER CHANNEL OUTPUT
- INSERTION LOSS PER CHANNEL:  
7 dB TYP ( $Z_0 = 50 \Omega$ )
- FREQUENCY RANGE:  
950 MHz to 2150 MHz
- CHANNEL TO CHANNEL ISOLATION:  
26.5 dB TYP
- SMALL 16 PIN HTSSOP PACKAGE

### DESCRIPTION

The UPG183GR is intended for use in Direct Broadcast Satellite (DBS) applications within the Low Noise Block (LNB) down converter, for systems where at least two LNB outputs are required. It offers four intermediate frequency amplifier channels that can independently select 1 of 4 IF inputs. It is housed in a very small 16 pin plastic HTSSOP package, available on tape-and-reel, easy to install and contributes to miniaturizing the systems.

### OUTLINE DIMENSIONS (Units in mm)

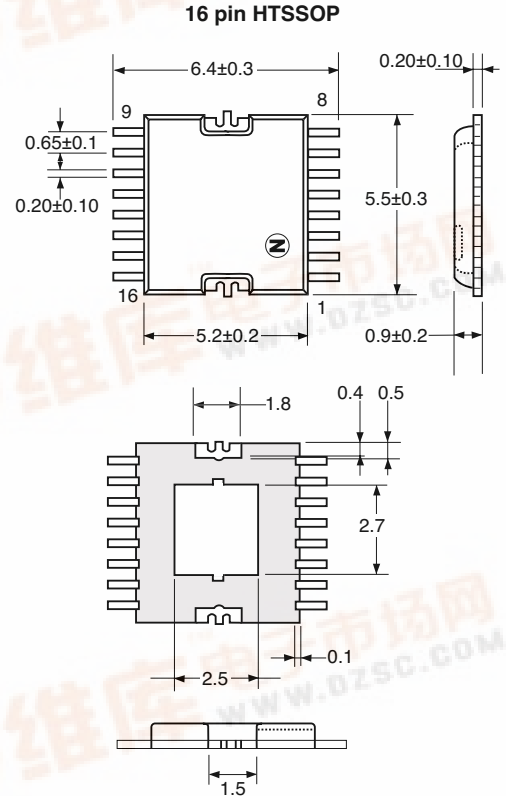

### ELECTRICAL CHARACTERISTICS

( $T_A = +25^\circ\text{C}$ , unless otherwise specified,  $V_{\text{CONT}1}$  to  $V_{\text{CONT}8} = 0/+5 \text{ V}$ ,  $P_{\text{IN}} = 0 \text{ dBm}$ ,  $Z_0 = 50 \Omega$ , Each Port)

PART NUMBER PACKAGE OUTLINE			UPG183GR 16 pin HTSSOP		
SYMBOLS	PARAMETERS AND CONDITIONS	UNITS	MIN	TYP	MAX
LINS 1	Insertion Loss 1, $f = 0.95 \text{ GHz to } 1.5 \text{ GHz}$	dB	—	7.0	9.0
LINS 2	Insertion Loss 2, $f = 1.5 \text{ GHz to } 2.15 \text{ GHz}$	dB	—	8.0	10.0
$\Delta\text{LINS}$	Insertion Loss Flatness,   LINS (0.95 GHz) — LINS (2.15 GHz)	dB	—	1.5	3.0
ISOL 1	Channel Isolation 1, $f = 0.95 \text{ GHz to } 1.5 \text{ GHz}$	dB	24	26.5	—
ISOL 2	Channel Isolation 2, $f = 1.5 \text{ GHz to } 2.15 \text{ GHz}$	dB	22	23.5	—
RL(OUT)	Output Return Loss, $f = 0.95 \text{ GHz to } 2.15 \text{ GHz}$	dB	10	14	—
ICONT	Control Current <sup>1</sup> , $V_{\text{CONT}} = +5 \text{ V/0 V}$ , $R_{\text{Foff}}$	mA	—	—	0.5

Notes:

1. Per one control pin.

# UPG183GR

## ABSOLUTE MAXIMUM RATINGS<sup>1</sup> (T<sub>A</sub> = +25°C)

SYMBOLS	PARAMETERS	UNITS	RATINGS
V <sub>CONT1-8</sub>	Control Voltage 1-8	V	-1.0 to +6.0
P <sub>TOT</sub>	Total Power Dissipation <sup>2</sup>	W	2
P <sub>IN</sub>	Input Power	dBm	+ 10
T <sub>A</sub>	Operating Ambient Temp.	°C	-40 to +85
T <sub>STG</sub>	Storage Temperature	°C	-65 to +150

### Notes:

1. Operation in excess of any one of these parameters may result in permanent damage.
2. Mounted on a 50x50x1.6 mm double copper clad epoxy glass PWB, T<sub>A</sub> = +85°C.

## RECOMMENDED OPERATING CONDITIONS (T<sub>A</sub> = +25°C)

SYMBOLS	PARAMETERS	UNITS	MIN	TYP	MAX
V <sub>CONT(H)</sub>	Control Voltage (High)	V	+4.5	+5	+5.5
V <sub>CONT(L)</sub>	Control Voltage (Low)	V	-0.5	0	+0.5

## EVALUATION CIRCUIT (V<sub>CONT1</sub> to V<sub>CONT8</sub> = 0/+5 V, P<sub>IN</sub> = 0 dBm, Z<sub>o</sub> = 50 Ω, DC Blocking Capacitor = 51 pF)

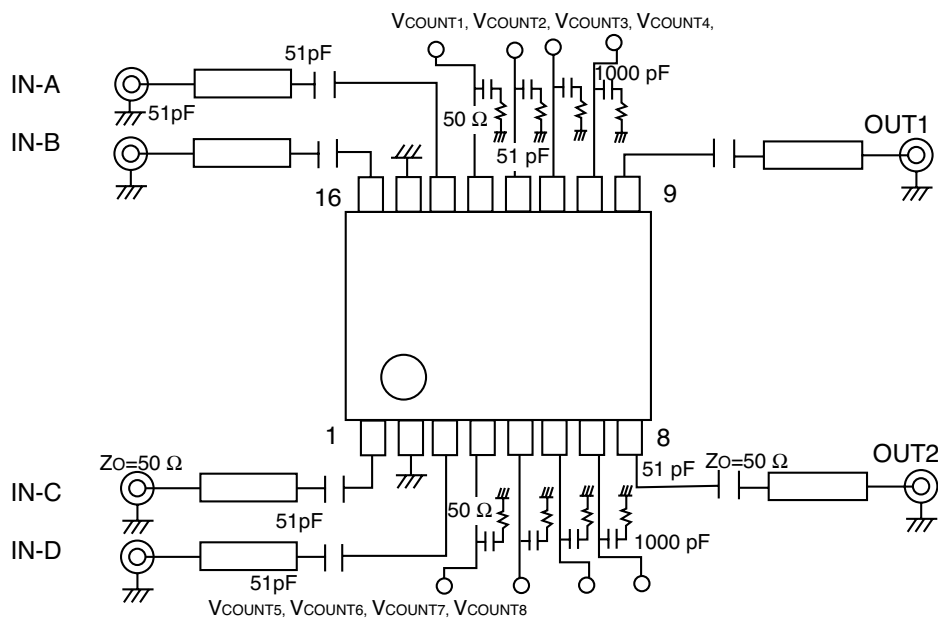

## CHANNEL SELECT TRUTH TABLE

ON CHANNEL		CONTROL PIN							
OUT1	OUT2	V <sub>CONT1</sub>	V <sub>CONT2</sub>	V <sub>CONT3</sub>	V <sub>CONT4</sub>	V <sub>CONT5</sub>	V <sub>CONT6</sub>	V <sub>CONT7</sub>	V <sub>CONT8</sub>
IN-A	–	High	Low	High	Low	–	–	–	–
IN-B	–	High	Low	Low	High	–	–	–	–
IN-C	–	Low	High	High	Low	–	–	–	–
IN-D	–	Low	High	Low	High	–	–	–	–
–	IN-A	–	–	–	–	High	Low	High	Low
–	IN-B	–	–	–	–	High	Low	Low	High
–	IN-C	–	–	–	–	Low	High	High	Low
–	IN-D	–	–	–	–	Low	High	Low	High

**PIN CONNECTION AND INTERNAL BLOCK DIAGRAM**

PIN NO.	CONNECTION	PIN NO.	CONNECTION
1	IN-C	9	OUT1
2	GND	10	VCONT4
3	IN-D	11	VCONT3
4	VCONT5	12	VCONT2
5	VCONT6	13	VCONT1
6	VCONT7	14	IN-A
7	VCONT8	15	GND
8	OUT2	16	IN-B

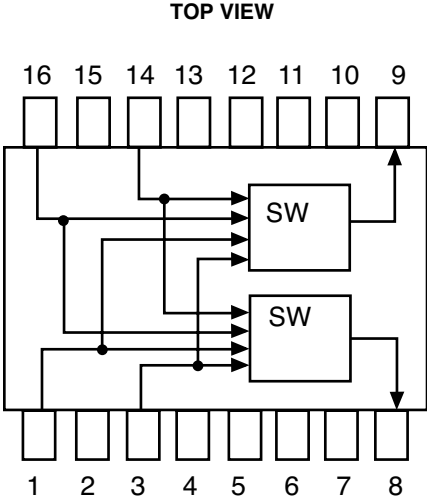

**ORDERING INFORMATION**

PART NUMBER	PACKAGE	QUANTITY
UPG183GR-E1	16-pin Plastic HTSSOP	Qty. 3k pcs/Reel

Notes:  
 1. Carrier tape, 12 mm wide.