

POWER SCHOTTKY RECTIFIERS

150 Amp Pk, Up to 25V

捷多邦, 专业USD7520厂, 24小时加急出货
USD7525

2

FEATURES

- Extremely Low Forward Voltage (0.425V at 60A, 125°C)
- High Efficiency for Low Voltage Supplies (3V types)
- Low Recovered Charge
- Rugged Package Design (DO-5)
- Low Thermal Resistance (0.7°C/W)
- High Surge Current (1000A)
- Low Reverse Current (150mA at Rated V_R at 125°C)

DESCRIPTION

This series of Schottky barrier power rectifiers is specifically designed to be used as output rectifiers and catch diodes for 3V power supplies. The Microsemi high conductivity design, using a heavy copper top post and 4 point crimp, ensures cool thermal operation and low dynamic impedance. Rugged design absorbs stress that can damage glass-to-metal seal during installation and use.

ABSOLUTE MAXIMUM RATINGS

	USD7520	USD7525
Working Peak Reverse Voltage, V_{RWM}	20V	25V
DC Blocking Voltage, V_R	20V	25V
Peak Repetitive Surge Voltage, V_{RSM} @ I_{RSM}	24V	30V
Peak Repetitive Forward Current (Rated V_R , Square Wave, 20kHz, 50% Duty Cycle), I_{FRM} ($T_C = 130^\circ\text{C}$)	150A	
Average Rectified Forward Current, I_{FAV} ($T_C = 130^\circ\text{C}$)	.75A	
Non-Repetitive Peak Surge Current (8.3ms), I_{FSM}	1000A	
Peak Reverse Transient Current, I_{RM}	2A	
Storage Temperature Range, T_{stg}	-55°C to +200°C	
Operating Junction Temperature, T_J	+175°C	
Thermal Resistance, Junction-to-Case, $R_{\theta JC}$	0.7°C/W	

ELECTRICAL CHARACTERISTICS ($T_{CASE} = 25^\circ\text{C}$ unless noted.)

CHARACTERISTICS	SYMBOL	LIMIT		UNITS	CONDITIONS
		20V	25V		
Maximum Instantaneous Reverse Current	i_R	20 (100)	20 (150)	mA	$V_R = V_{RWM}$ ($T_C = 125^\circ\text{C}$) Pulse Width = 300 μs Duty Cycle = 1 percent
Maximum Instantaneous Forward Voltage	V_F	0.425 0.450 0.550		V V V	$i_F = 60\text{A}$, $T_C = 125^\circ\text{C}$ $i_F = 75\text{A}$, $T_C = 125^\circ\text{C}$ $i_F = 150\text{A}$, $T_C = 125^\circ\text{C}$
Maximum Capacitance	C_t	5000		pF	$V_R = 5.0\text{V}$
Maximum Voltage Rate of Change	dv/dt	1000		V/ μs	$V_R = \text{rated}$

MECHANICAL SPECIFICATIONS

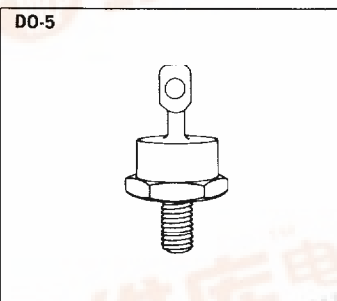
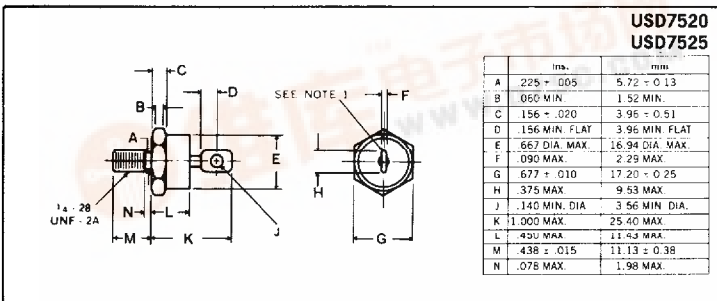

Notes:

1. Cathode is stud.
2. All metal surfaces tin plated.
3. Maximum unlubricated stud torque: 30 inch pounds (35 kg. cm).
4. Angular orientation of terminal is undefined.

9/86

2-131

Microsemi Corp.
Watertown
The diode experts



