



**FEATURES**

- Access time : 35/70ns (max.)
- Low power consumption:  
Operating : 45/30mA (max.)  
Standby :  
2uA (typical) L-version  
1uA (typical) LL-version
- Single 5V power supply
- All inputs and outputs TTL compatible
- Fully static operation
- Six transistors memory cell.
- Three state outputs
- Data retention voltage : 2V (min.)
- Package : 28-pin 600 mil PDIP  
28-pin 330 mil SOP  
28-pin 8x13.4mm TSOP-I

**GENERAL DESCRIPTION**

The UT62256B is a 262,144-bit low power CMOS static random access memory organized as 32,768 words by 8 bits. It is fabricated using high performance, high reliability CMOS technology with 6T cell. Its standby current is stable within the rang of operating temperature.

The UT62256B is designed for high-speed and low power application. It is particularly well suited for battery back-up nonvolatile memory application.

The UT62256B operates from a single 5V power supply and all inputs and outputs are fully TTL compatible

**FUNCTIONAL BLOCK DIAGRAM**

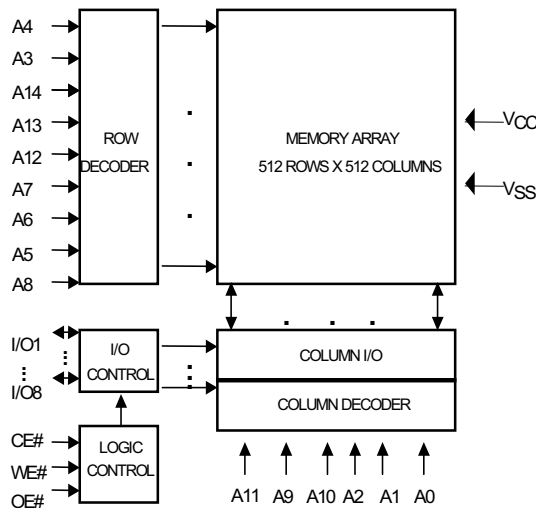

**PIN CONFIGURATION**

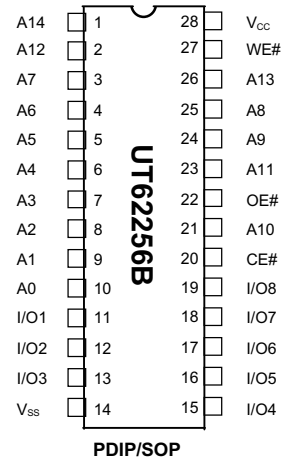

**PIN DESCRIPTION**

SYMBOL	DESCRIPTION
A0 - A14	Address Inputs
I/O1 - I/O8	Data Inputs/Outputs
CE#	Chip Enable Input
WE#	Write Enable Input
OE#	Output Enable Input
V <sub>CC</sub>	Power Supply
V <sub>SS</sub>	Ground

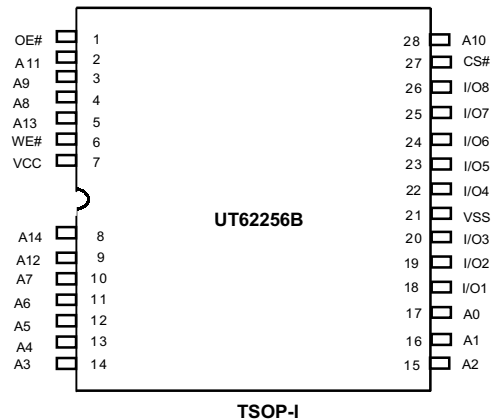

**ABSOLUTE MAXIMUM RATINGS\***

PARAMETER	SYMBOL	RATING	UNIT
Terminal Voltage with Respect to $V_{SS}$	$V_{TERM}$	-0.5 to +7.0	V
Operating Temperature	$T_A$	0 to +70	°C
Storage Temperature	$T_{STG}$	-65 to +150	°C
Power Dissipation	$P_D$	1	W
DC Output Current	$I_{OUT}$	50	mA
Soldering Temperature (under 10 sec)	$T_{solder}$	260	°C

\*Stresses greater than those listed under "Absolute Maximum Ratings" may cause permanent damage to the device. This is a stress rating only and functional operation of the device or any other conditions above those indicated in the operational sections of this specification is not implied. Exposure to the absolute maximum rating conditions for extended period may affect device reliability.

**TRUTH TABLE**

MODE	CE#	OE#	WE#	I/O OPERATION	SUPPLY CURRENT
Standby	H	X	X	High - Z	$I_{SB}, I_{SB1}$
Output Disable	L	H	H	High - Z	$I_{CC}$
Read	L	L	H	$D_{OUT}$	$I_{CC}$
Write	L	X	L	$D_{IN}$	$I_{CC}$

Note: H =  $V_{IH}$ , L =  $V_{IL}$ , X = Don't care.

**DC ELECTRICAL CHARACTERISTICS ( $V_{CC} = 5V \pm 10\%$ ,  $T_A = 0^\circ C$  to  $70^\circ C$ )**

PARAMETER	SYMBOL	TEST CONDITION	MIN.	TYP.	MAX.	UNIT	
Input High Voltage	$V_{IH}$		2.2	-	$V_{CC}+0.5$	V	
Input Low Voltage	$V_{IL}$		-0.5	-	0.8	V	
Input Leakage Current	$I_{LI}$	$V_{SS} \leq V_{IN} \leq V_{CC}$	-1	-	1	$\mu A$	
Output Leakage Current	$I_{LO}$	$V_{SS} \leq V_{IO} \leq V_{CC}$ CE#= $V_{IH}$ or OE# = $V_{IH}$ or WE# = $V_{IL}$	-1	-	1	$\mu A$	
Output High Voltage	$V_{OH}$	$I_{OH} = -1mA$	2.4	-	-	V	
Output Low Voltage	$V_{OL}$	$I_{OL} = 4mA$	-	-	0.4	V	
Average Operating Power supply Current	$I_{CC}$	CE# = $V_{IL}$ , $I_{IO} = 0mA$ , Cycle=Min.	-35	-	-	45	mA
			-70	-	-	30	mA
	$I_{CC1}$	Tcycle=500ns CE#=0.2V; $I_{IO} = 0mA$ other pins at 0.2V or $V_{CC}-0.2V$	-	-	-	20	mA
	$I_{CC2}$	Tcycle=1us CE#=0.2V; $I_{IO} = 0mA$ other pins at 0.2V or $V_{CC}-0.2V$ ;	-	-	-	10	mA
Standby Power Supply Current	$I_{SB}$	CE# = $V_{IH}$	-	-	-	3	mA
			-L	-	2	40	$\mu A$
	$I_{SB1}$	CE# $\geq V_{CC}-0.2V$	-LL	-	1	5	$\mu A$

**CAPACITANCE** ( $T_A=25^{\circ}\text{C}$ ,  $f=1.0\text{MHz}$ )

PARAMETER	SYMBOL	MIN.	MAX.	UNIT
Input Capacitance	$C_{IN}$	-	8	pF
Input/Output Capacitance	$C_{I/O}$	-	10	pF

Note : These parameters are guaranteed by device characterization, but not production tested.

**AC TEST CONDITIONS**

Input Pulse Levels	0V to 3.0V
Input Rise and Fall Times	5ns
Input and Output Timing Reference Levels	1.5V
Output Load	$C_L = 100\text{pF}$ , $I_{OH}/I_{OL} = -1\text{mA}/4\text{mA}$

**AC ELECTRICAL CHARACTERISTICS** ( $V_{CC} = 5V \pm 10\%$ ,  $T_A = 0^{\circ}\text{C}$  to  $70^{\circ}\text{C}$ )**(1) READ CYCLE**

PARAMETER	SYMBOL	UT62256B-35		UT62256B-70		UNIT
		MIN.	MAX.	MIN.	MAX.	
Read Cycle Time	$t_{RC}$	35	-	70	-	ns
Address Access Time	$t_{AA}$	-	35	-	70	ns
Chip Enable Access Time	$t_{ACE}$	-	35	-	70	ns
Output Enable Access Time	$t_{OE}$	-	25	-	35	ns
Chip Enable to Output in Low Z	$t_{CLZ}^*$	10	-	10	-	ns
Output Enable to Output in Low Z	$t_{OLZ}^*$	5	-	5	-	ns
Chip Disable to Output in High Z	$t_{CHZ}^*$	-	25	-	35	ns
Output Disable to Output in High Z	$t_{OHZ}^*$	-	25	-	35	ns
Output Hold from Address Change	$t_{OH}$	5	-	5	-	ns

**(2) WRITE CYCLE**

PARAMETER	SYMBOL	UT62256B-35		UT62256B-70		UNIT
		MIN.	MAX.	MIN.	MAX.	
Write Cycle Time	$t_{WC}$	35	-	70	-	ns
Address Valid to End of Write	$t_{AW}$	30	-	60	-	ns
Chip Enable to End of Write	$t_{CW}$	30	-	60	-	ns
Address Set-up Time	$t_{AS}$	0	-	0	-	ns
Write Pulse Width	$t_{WP}$	25	-	50	-	ns
Write Recovery Time	$t_{WR}$	0	-	0	-	ns
Data to Write Time Overlap	$t_{DW}$	20	-	30	-	ns
Data Hold from End of Write Time	$t_{DH}$	0	-	0	-	ns
Output Active from End of Write	$t_{OW}^*$	5	-	5	-	ns
Write to Output in High Z	$t_{WHZ}^*$	-	15	-	25	ns

\*These parameters are guaranteed by device characterization, but not production tested.



**TIMING WAVEFORMS**

**READ CYCLE 1 (Address Controlled) (1,2,4)**

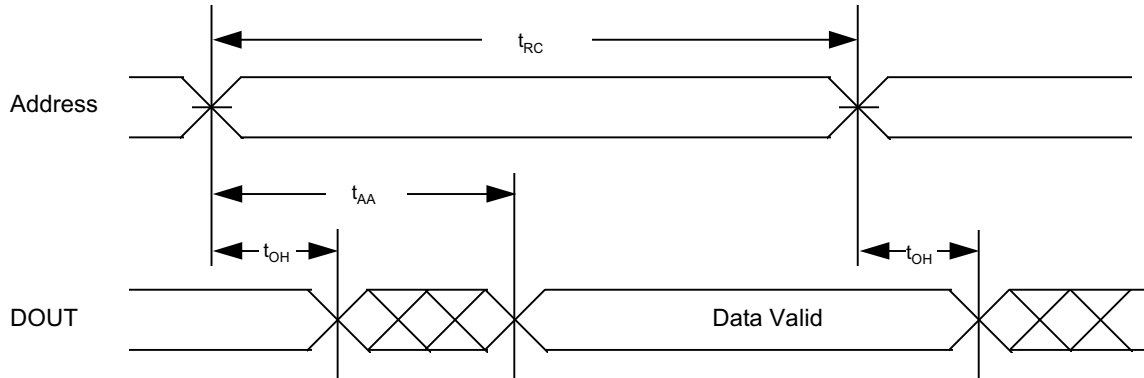

**READ CYCLE 2 (CE# and OE# Controlled) (1,3,5,6)**

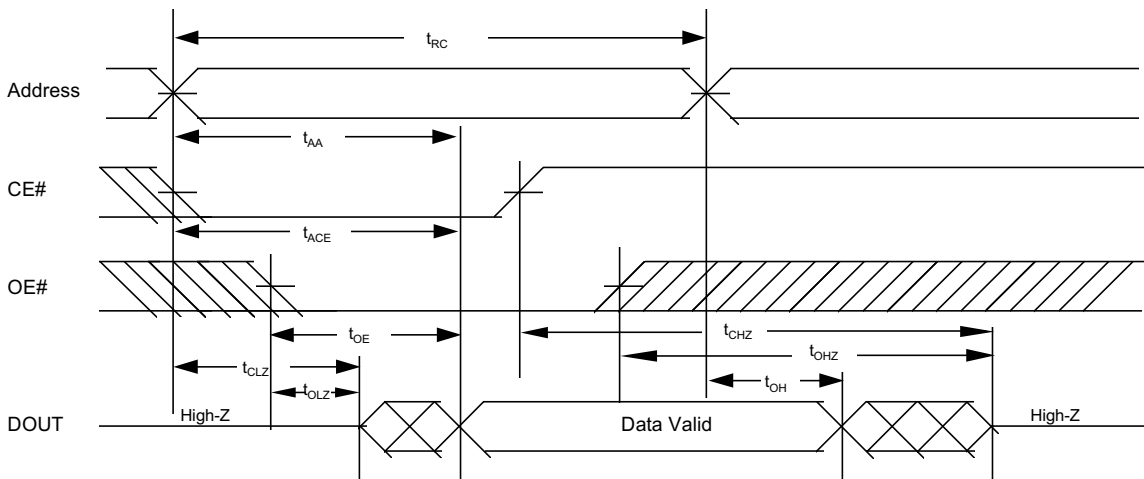

Notes :

1. WE# is HIGH for read cycle.
2. Device is continuously selected CE#=VIL.
3. Address must be valid prior to or coincident with CE# transition; otherwise  $t_{AA}$  is the limiting parameter.
4. OE# is LOW.
5.  $t_{CLZ}$ ,  $t_{OLZ}$ ,  $t_{CHZ}$  and  $t_{OHZ}$  are specified with  $C_L=5pF$ . Transition is measured  $\pm 500mV$  from steady state.
6. At any given temperature and voltage condition,  $t_{CHZ}$  is less than  $t_{CLZ}$ ,  $t_{OHZ}$  is less than  $t_{OLZ}$ .



WRITE CYCLE 1 (WE# Controlled) (1,2,3,5)

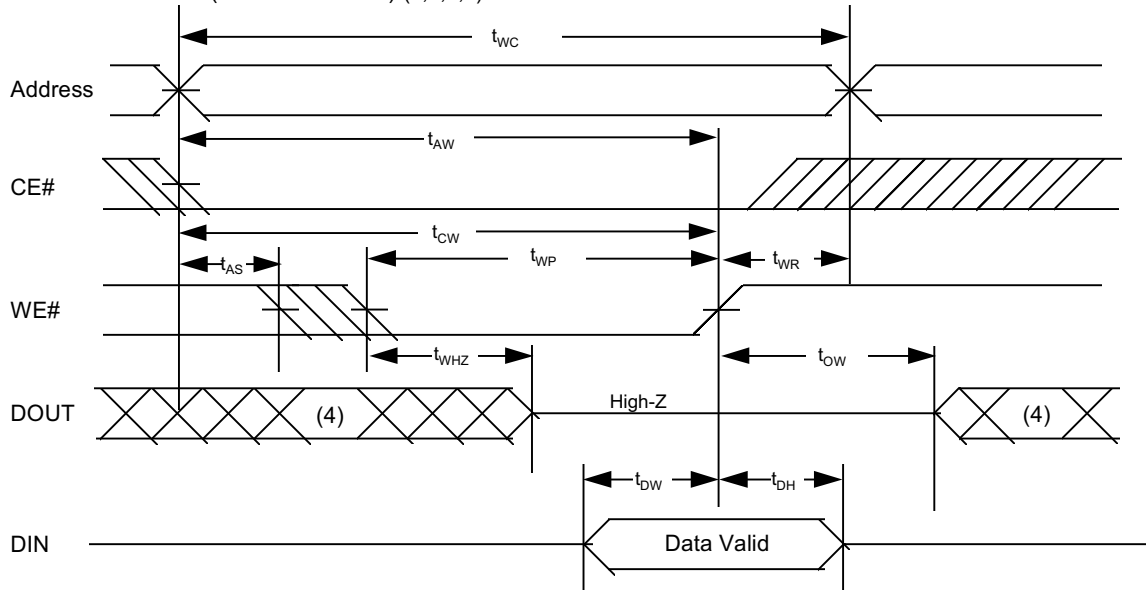

WRITE CYCLE 2 (CE# Controlled) (1,2,5)

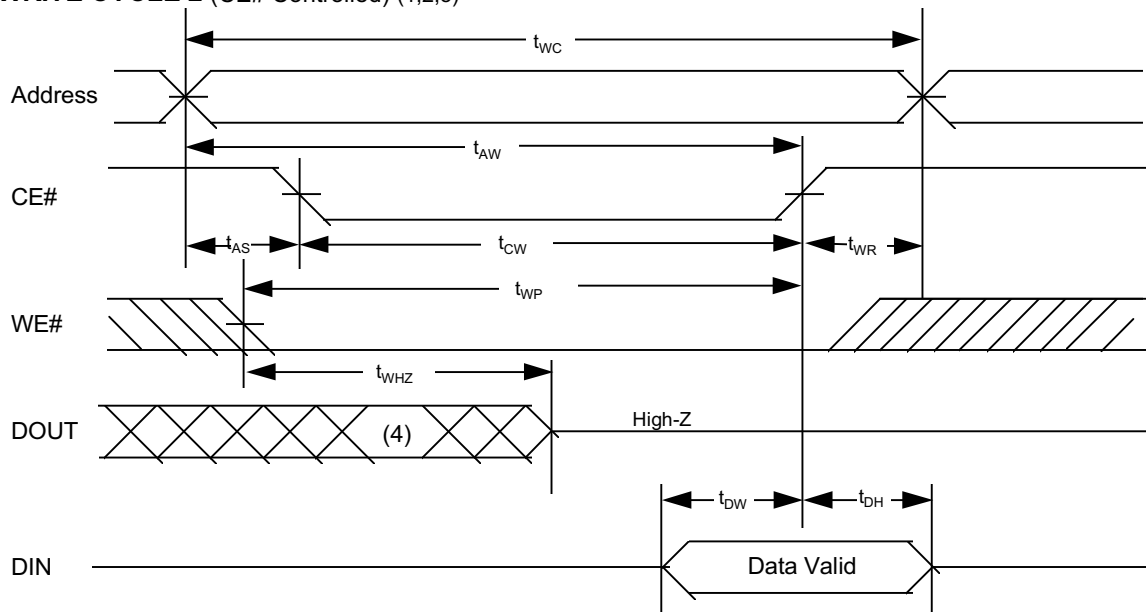

Notes :

1. WE# or CE# must be HIGH during all address transitions.
2. A write occurs during the overlap of a low CE# and a low WE#.
3. During a WE# controlled with write cycle with OE# LOW,  $t_{WP}$  must be greater than  $t_{WHZ} + t_{OW}$  to allow the I/O drivers to turn off and data to be placed on the bus.
4. During this period, I/O pins are in the output state, and input signals must not be applied.
5. If the CE# LOW transition occurs simultaneously with or after WE# LOW transition, the outputs remain in a high impedance state.
6.  $t_{OW}$  and  $t_{WHZ}$  are specified with  $C_L = 5pF$ . Transition is measured  $\pm 500mV$  from steady state.



DATA RETENTION CHARACTERISTICS (TA = 0°C to 70°C)

PARAMETER	SYMBOL	TEST CONDITION	MIN.	TYP.	MAX.	UNIT
V <sub>CC</sub> for Data Retention	V <sub>DR</sub>	CE# ≥ V <sub>CC</sub> -0.2V	2.0	-	5.5	V
Data Retention Current	I <sub>DR</sub>	V <sub>CC</sub> =3V CE# ≥ V <sub>CC</sub> -0.2V	- L	1	20	μA
			- LL	0.5	5	μA
Chip Disable to Data Retention Time	t <sub>CDR</sub>	See Data Retention Waveforms (below)	0	-	-	ns
Recovery Time	t <sub>R</sub>		t <sub>RC</sub> *	-	-	ns

t<sub>RC</sub>\* = Read Cycle Time

DATA RETENTION WAVEFORM

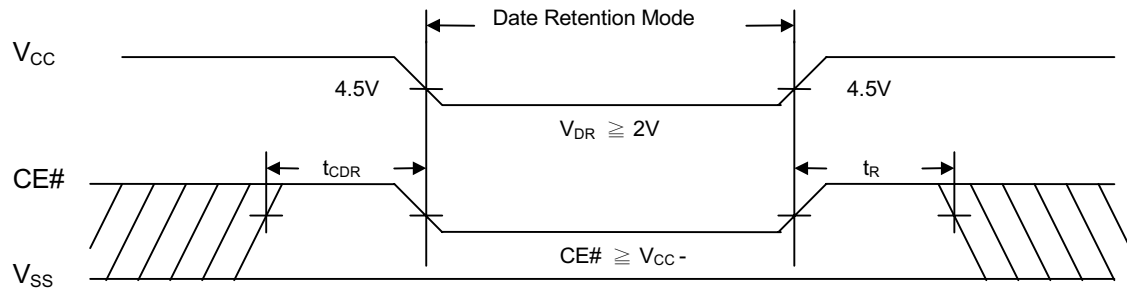



PACKAGE OUTLINE DIMENSION

28 pin 600 mil PDIP Package Outline Dimension

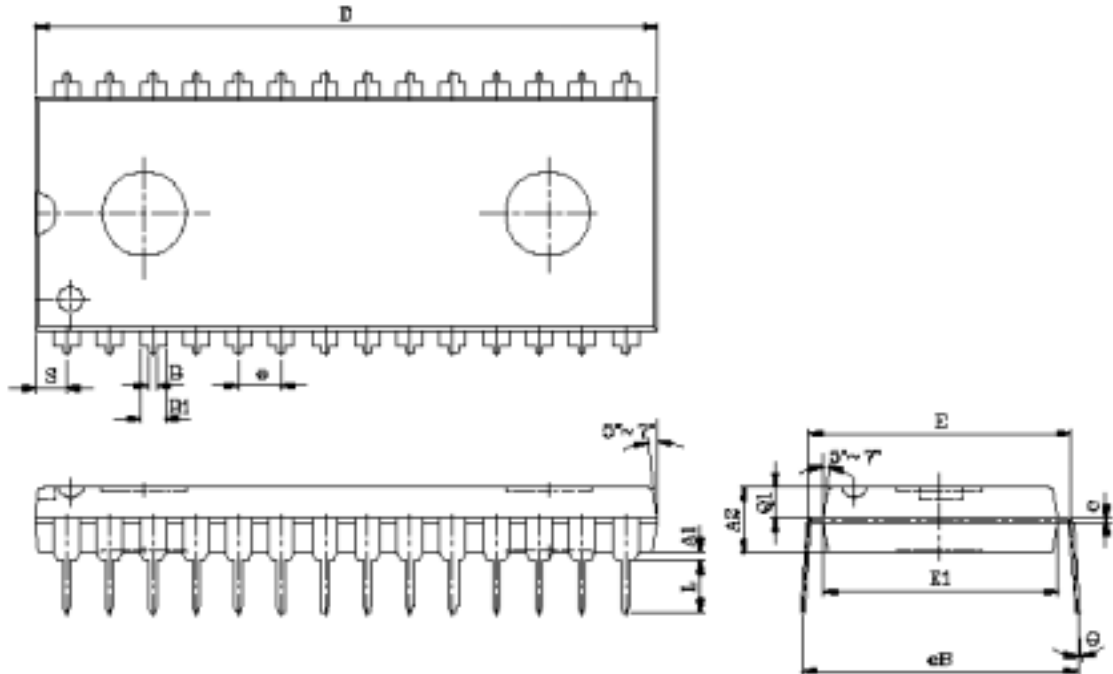

SYMBOL	UNIT	INCH(BASE)	MM(REF)
A1		0.010 (MIN)	0.254 (MIN)
A2		0.150± 0.005	3.810± 0.127
B		0.020 (MAX)	0.508(MAX)
B1		0.055 (MAX)	1.397(MAX)
c		0.012 (MAX)	0.304 (MAX)
D		1.430 (MAX)	36.322 (MAX)
E		0.6 (TYP)	15.24 (TYP)
E1		0.52 (MAX)	13.208 (MAX)
e		0.100 (TYP)	2.540(TYP)
eB		0.625 (MAX)	15.87 (MAX)
L		0.180(MAX)	4.572(MAX)
S		0.06 (MAX)	1.524 (MAX)
Q1		0.08(MAX)	2.032(MAX)
θ		15°(MAX)	15°(MAX)



UTRON

Rev 1.0

UT62256B  
32K X 8 BIT LOW POWER (6T) CMOS SRAM

28 pin 330 mil SOP Package Outline Dimension

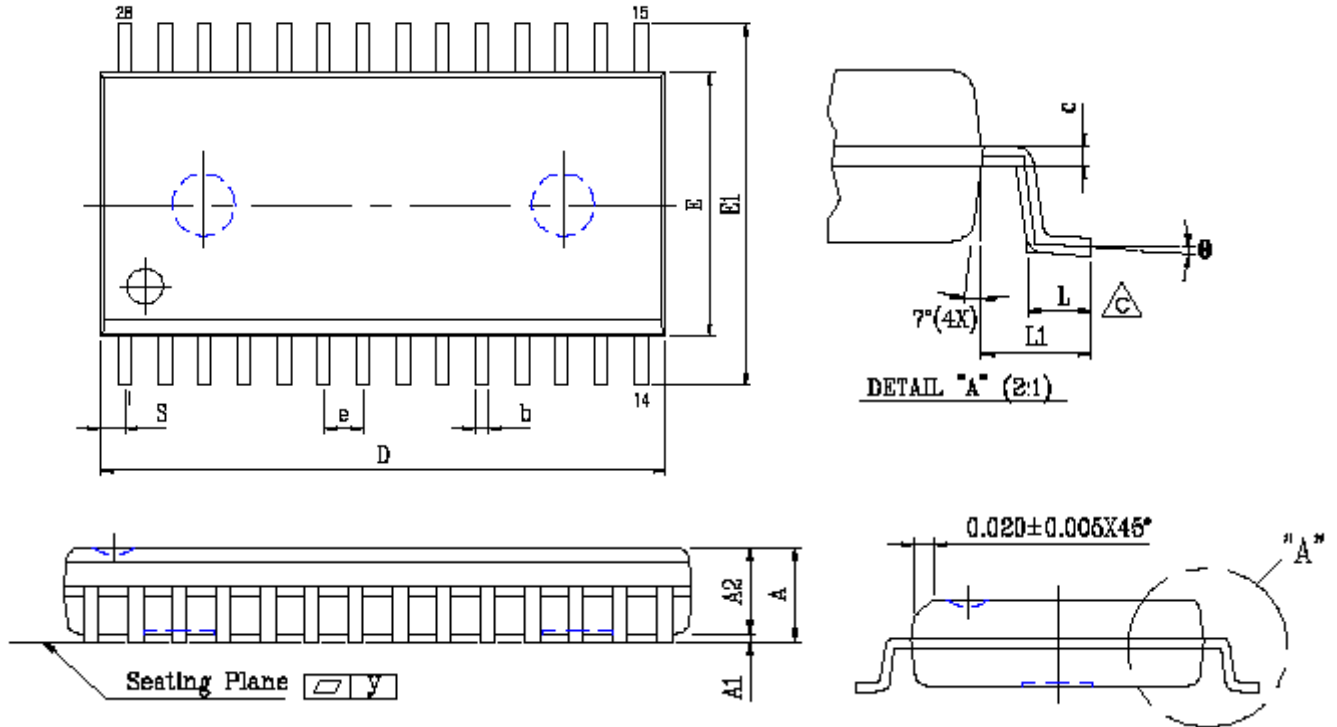

SYMBOL	UNIT	INCH(BASE)	MM(REF)
A		0.120 (MAX)	3.048 (MAX)
A1		0.002(MIN)	0.05(MIN)
A2		0.098± 0.005	2.489± 0.127
b		0.016 (TYP)	0.406(TYP)
c		0.010 (TYP)	0.254(TYP)
D		0.728 (MAX)	18.491 (MAX)
E		0.340 (MAX)	8.636 (MAX)
E1		0.465± 0.012	11.811± 0.305
e		0.050 (TYP)	1.270(TYP)
L		0.05 (MAX)	1.270 (MAX)
L1		0.067± 0.008	1.702 ± 0.203
S		0.047 (MAX)	1.194 (MAX)
y		0.003(MAX)	0.076(MAX)
θ		0°~10°	0°~10°







28 pin 8x13.4mm TSOP-I Package Outline Dimension

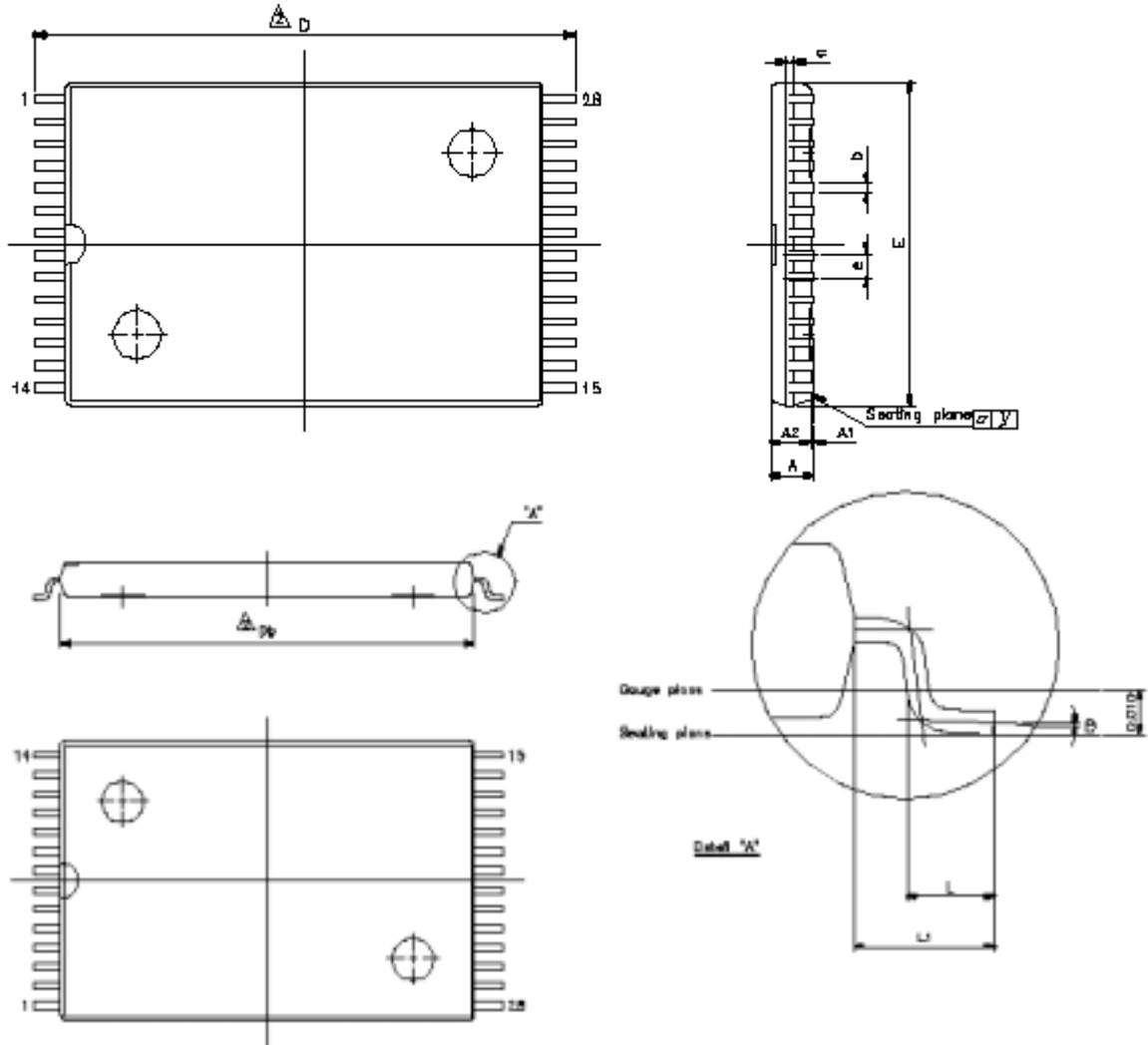

Note :  
 E dimension is not including end flash  
 The total of both sides' end flash is  
 Not above 0.3mm.

UNIT SYMBOL	INCH(BASE)	MM(REF)
A	0.047 (MAX)	1.20 (MAX)
A1	0.004± 0.002	0.10± 0.05
A2	0.039± 0.002	1.00± 0.05
b	0.006 (TYP)	0.15(TYP)
c	0.010 (TYP)	0.254(TYP)
$\Delta$ Db	0.465± 0.004	11.80± 0.10
E	0.315± 0.004	8.00± 0.10
e	0.022 (TYP)	0.55(TYP)
$\Delta$ D	0.528± 0.008	13.40± 0.20
$\Delta$ L	0.020± 0.004	0.50± 0.10
$\Delta$ L1	0.0315± 0.004	0.80± 0.10
$\Delta$ y	0.08(MAX)	0.003(MAX)
$\theta$	0°~5°	0°~5°



UTRON

Rev 1.0

UT62256B

32K X 8 BIT LOW POWER (6T) CMOS SRAM

**ORDERING INFORMATION**

PART NO.	ACCESS TIME (ns)	STANDBY CURRENT ( $\mu$ A)	PACKAGE
UT62256BPC-70L	70	40 $\mu$ A	28PIN PDIP
UT62256BPC-70LL	70	5 $\mu$ A	28PIN PDIP
UT62256BSC-35L	35	40 $\mu$ A	28PIN SOP
UT62256BSC-35LL	35	5 $\mu$ A	28PIN SOP
UT62256BSC-70L	70	40 $\mu$ A	28PIN SOP
UT62256BSC-70LL	70	5 $\mu$ A	28PIN SOP
UT62256BLS-35L	35	40 $\mu$ A	28PIN TSOP-I
UT62256BLS-35LL	35	5 $\mu$ A	28PIN TSOP-I
UT62256BLS-70L	70	40 $\mu$ A	28PIN TSOP-I
UT62256BLS-70LL	70	5 $\mu$ A	28PIN TSOP-I

Copyright © Each Manufacturing Company.

All Datasheets cannot be modified without permission.

This datasheet has been download from :

[www.AllDataSheet.com](http://www.AllDataSheet.com)

100% Free DataSheet Search Site.

Free Download.

No Register.

Fast Search System.

[www.AllDataSheet.com](http://www.AllDataSheet.com)