

## UTC UT84520

## CMOS IC

### PS/2 SCROLLING MOUSE CONTROLLER

#### DESCRIPTION

The UT84520 Scrolling Mouse Controller is specially designed to control PS/2 mouse device. This single chip can interface with three key-switches and 4X-Y photo-couples plus Z-axis directly to 8042 controller.

There are four types of Z-axis inputs used to implement scrolling mouse functionality.

#### FEATURES

- \*Using 50K $\Omega$  +5% resistor for RC oscillation.
- \*Compatible with legacy PS/2 mouse.
- \*Compatible with Microsoft PS/2 scrolling mouse.
- \*Built-in noise immunity circuit.
- \*The sampling rate of motion detector is up to 65KHz.
- \*Built-in three step dynamic input impedance.
- \*Three key-switches and four photo-couples inputs.
- \*Photo couple test mode included .
- \*Low power dissipation.
- \*Two types Z direction input:
  - 1.Photo couples input
  - 2.Mechanical input

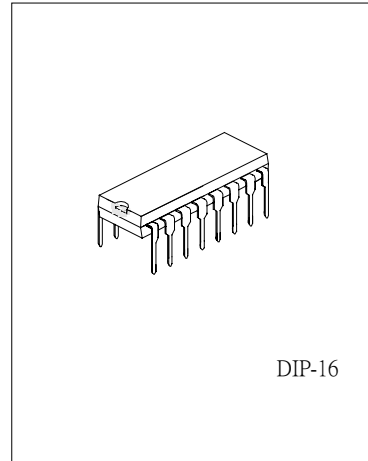

Pin Assignment

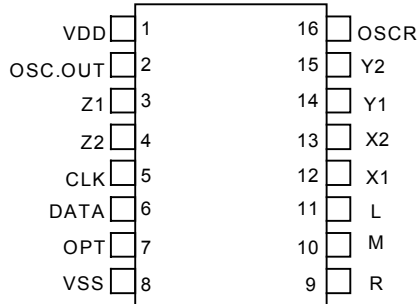

Pin Descriptions

Pin No	Symbol	I/O	Function
1	Vdd	P	Power line
2	OSC.OUT	O	The RC oscillation clock output. Or 3mA sink current output for X, Y photo emitters
3	Z1	I	Z-axis input.
4	Z2	I	Photo mode: three steps dynamic input impedance.
5	CLK	I/O	Connect to 8042 auxiliary port CLK line in PS/2 mode.
6	DATA	I/O	Connect to 8042 auxiliary port DATA line in PS/2 mode.
7	OPT	I	Input: 200Kohm pull low to Vss. When Opt is connected to Vdd, UT84520 will enter test mode. In test mode, L will be the output of X1, while M will be the output of X1. Toggling R key can change these output to be Y1, Y2 or Z1, Z2 respectively.
8	Vss	P	Power line Gnd
9	R	I	Three key switches inputs. 200Kohm pull low.
10	M	I/O	In Z-axis key mode, M key toggling can change the scrolling speed from low to high
11	L	I/O	
12	X1	I	Three step dynamic input impedance. If OSC.OUT is not connected to LEDs, the dynamic input impedance will be off.
13	X2	I	
14	Y1	I	
15	Y2	I	
16	OSCR	I	Connect 50Kohm ± 5% for oscillation

Functional Block Diagram

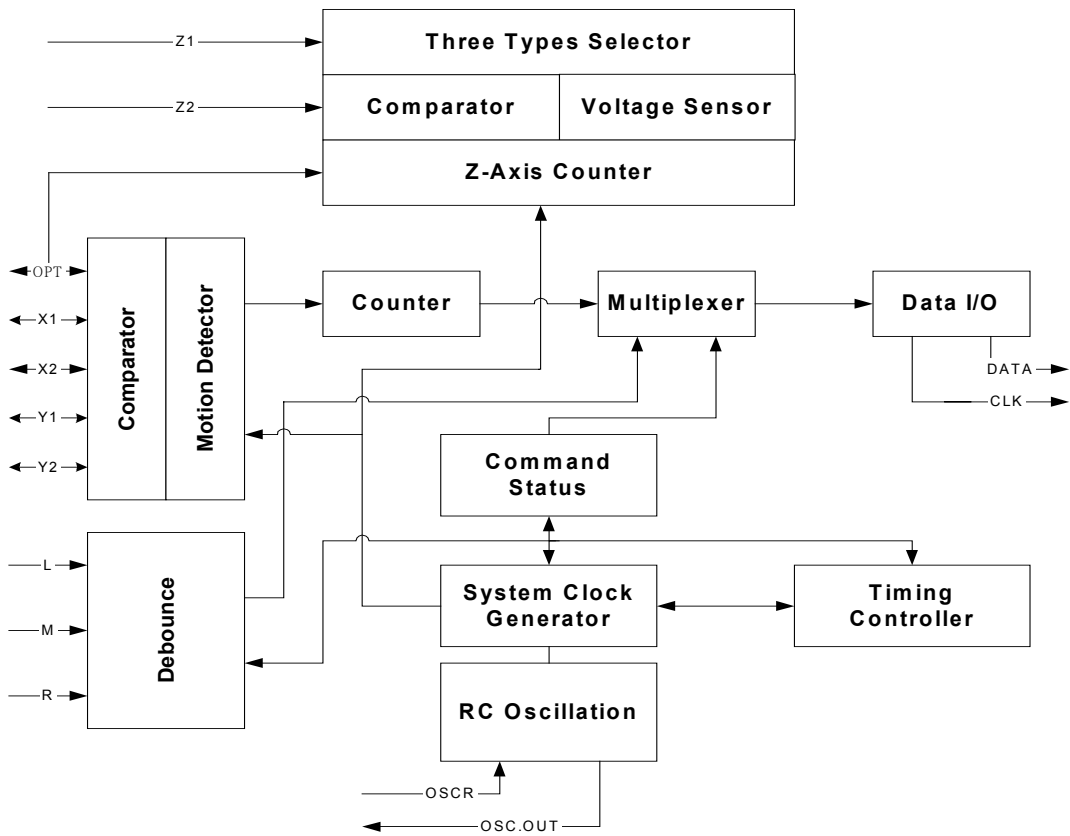

ABSOLUTE MAXIMUM RATINGS

PARAMETER	VALUE	UNIT
Supply voltage	-0.3~7.5	V
Power dissipation	500	mW
Temperature under bias	0~70	°C
Storage Temperature	-65~150	°C

## DC Electrical Characteristics (Ta = 25 °C~70 °C)

PARAMETER	SYMBOL	MIN	TYP	MAX	UNIT
X1,X2,Y1,Y2,Z1,Z2 (photo mode) Low input reference current	Ipl	70			uA
X1,X2,Y1,Y2,Z1,Z2 (photo mode) High input reference current	Iph			106	uA
X1,X2,Y1,Y2,Z1,Z2 (photo mode) Input current (input impedance) ( 80uA)	Vpl1	0.8		1.2	V
X1,X2,Y1,Y2,Z1,Z2 (photo mode) Input current (input impedance) ( 500uA)	Vpl2	1.5		2.1	V
L,M,R,OPT, Input low voltage	Vail			1.5	V
L,M,R,OPT, Input high voltage	Vaih	3.5		-	V
L,M,R Input current (Vin = 5V)	Imi	18		56	uA
OPT Input current	Ixi	-18		-56	uA
L,M,R,X1,X2,Y1,Y2,Z1,Z2 Input leakage current (Vin = 0V)	Iil	0		-1.0	uA
OPT Input leakage current (Vin = 5V)	Iih	0		1.0	UA
OSC.OUT Sink current	Iosc	3		3.6	MA

## PS/2 mouse mode : (Ta = 25 °C to 70 °C)

PARAMETER	SYMBOL	MIN	TYP	MAX	UNIT
Operating voltage	Vdd	4.5	5	5.5	V
Operating current (no load)	Iop			1	mA
CLK, DATA Positive-going threshold voltage	Vt+	3.2		3.8	V
CLK, DATA Negative-going threshold voltage	Vt-	1.2		1.9	V
DATA, CLK Input current (Vin = 0V)	I <sub>dc</sub>	0.56		1.86	mA
DATA, CLK Low output voltage (I <sub>pl</sub> = -2mA)	V <sub>prl</sub>			0.4	V

\*All parameters in above table are compared with VSS.

AC Electrical Characteristics (Ta = 25 °C to 70 °C)

PARAMETER	SYMBOL	MIN	TYP	MAX	UNIT
Oscillating Frequency	Fosc	37-3%	37	37+3%	KHz
Key Debounce	Tkd		12		ms
Rising Edge Crossed Width	Tr	13.5			µs
Falling Edge Crossed Width	Tf	13.5			µs
Mouse CLK Active Time	Tmca		40.5		µs
Mouse CLK Inactive Time	Tmci		40.5		µs
Time that Mouse Sample DATA from CLK rising Edge	Tmdc		13.5		µs
System CLK Active Time	Tsca		40.5		µs
System CLK Inactive Time	Tsci		40.5		µs
Time from DATA Transition to Falling Edge of CLK	Tsdc		13.5		µs
Time from rising Edge of CLK to DATA transition	Tscd		27.0		µs
Time to mouse Inhibit after the 11 <sup>th</sup> CLK to ensure mouse does not start another Transmission	Tpi	0		50	µs

Timing Diagram

(A) Photo-couples pulse width

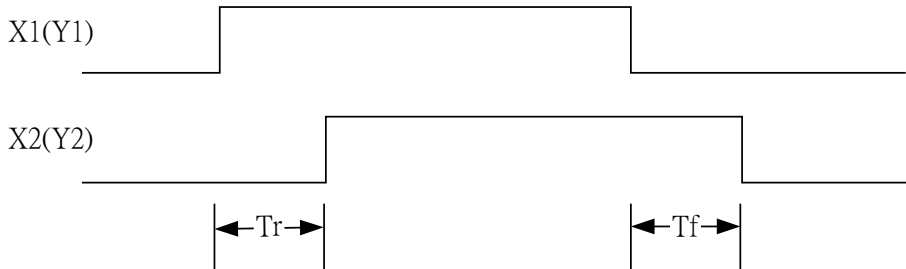

(B) Receiving Data

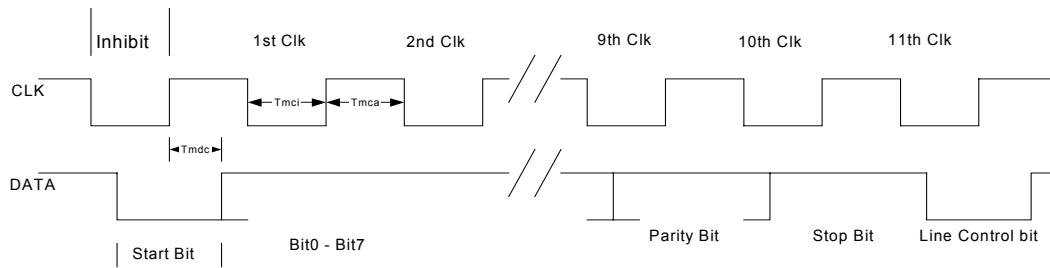

(C) Sending Data

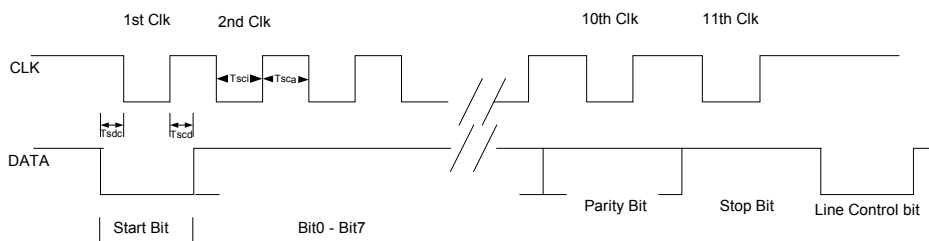

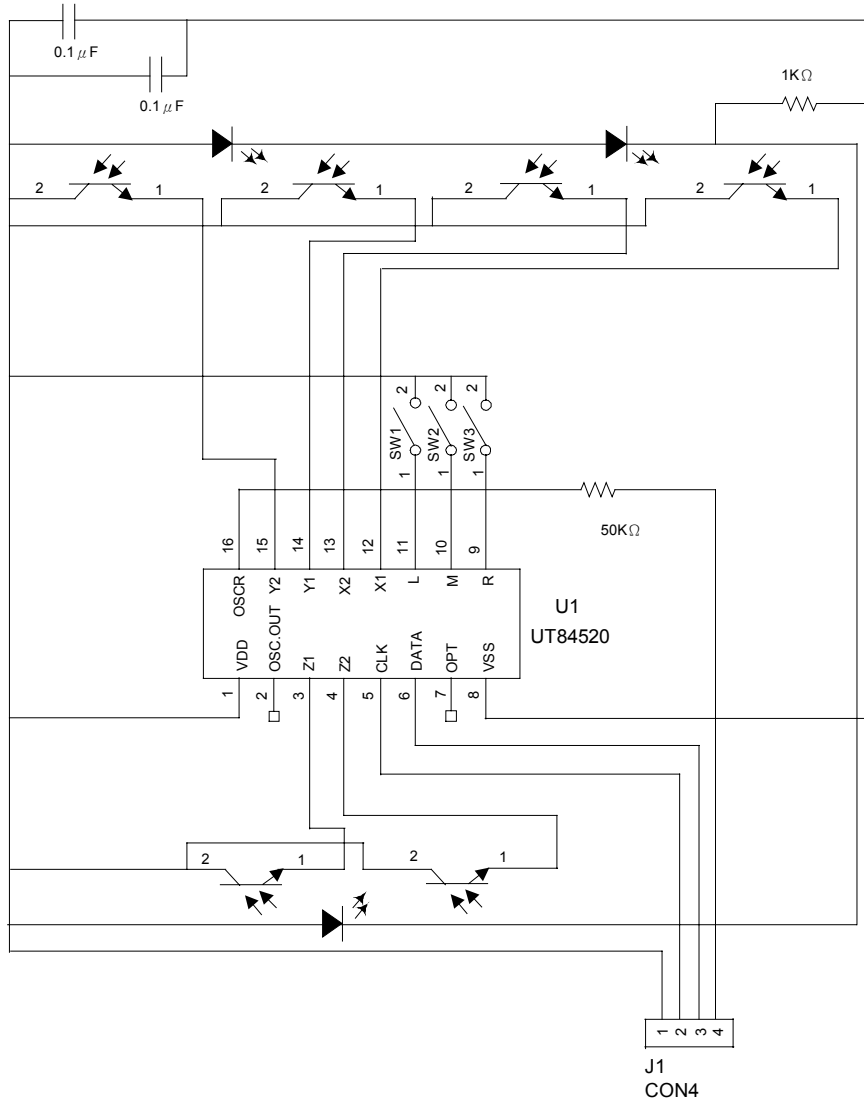

Function Descriptions

Legacy PS/2 mouse operating

A) Operating mode

There are four operating modes in PS/2 mouse:

a. Reset mode:

In this mode a self-test is initiated during power-on or by a Reset command. After reset signal, PS/2 mouse will

(a) Send completion code AA & ID code 00.

(b) Set default:

- Sampling rate: 100 reports/s
- Non-autospeed
- Stream mode
- 2 dots/count
- Disable

b. Stream Mode:

The maximum rate of transfer is the programmed sampling rate.

Data report is transmitted if

- (a) switch is pressed
- (b) movement has been detected

c. Remote Mode:

Data is transmitted only in response to a Read Data command

d. Wrap Mode:

Any byte of data sent by the system. Except hex EC (Reset Wrap mode) or hex FF (Reset). Is returned by UT84520.

B).PS/2 Mouse Data Report

- a). In stream mode: A data report is sent at the end of a sampling interval.
- b). In remote mode: A data report is sent in response to Read Data command
- c). Data report format:

Byte	Bit	Description
1	0	Left button status; 1=pressed
	1	Right button status; 1=pressed
	2	Middle button status; 1=pressed
	3	Reserve
	4	X data sign; 1=negative
	5	Y data sign; 1=negative
	6	X data overflow; 1=overflow
	7	Y data overflow; 1=overflow
2	0-7	X data (D0-D7)
3	0-7	Y data (D0-D7)



## C) PS/2 mouse Data Transmission:

- a) UT84520 generates the clocking signal when sending data to and receiving data from the system.
- b) The system requests UT84520 receive system data output by forcing the DATA line to an inactive level and allowing CLK line to go to an active level.
- c) Data transmission frame

Bit	Funtion
1	Start bit( always 0 )
2-9	Data bits (D0-D7 )
10	Parity bit (odd parity)
11	Stop bit (always 1)

## d). Data Output (data from UT84520 to system )

If CLK is low (inhibit status), data is no transmission.

If CLK is high and DATA is low (request-to-send), data is updated. Data is received from the system and no transmission are stored by UT84520 until CLK and DATA both high.

If CLK and DATA both are high, the transmission is ready. DATA is valid prior to the falling edge of CLK and beyond the rising edge of CLK. During transmission, UT84520 check for line contention by checking for an inactive level on CLK at intervals not to exceed 100u sec Contention occurs when the system lowers CLK to inhibit UT84520 output after UT84520 has started a transmission. If this occurs before the rising edge of the tenth clock, UT84520 internally store its data in its buffer and returns DATA and CLK to an active level. If the contention does not occur by the tenth clock, the transmission is complete.

Following a transmission the system inhibits UT84520 by holding CLK low until it service the input or until the system receives a request to send a response from UT84520.

## e).Data Input (from system to UT84520 )

The system first check if UT84520 is transmitting data. If UT84520 is transmitting, the system can override the output forcing CLK to an inactive level prior to the tenth clock. If UT84520 transmission is beyond the tenth clock, the system receives the data. If UT84520 is not transmitting or if the system choose to override the output, the system force CLK to an inactive level for a period of not less than 100u sec while preparing for output. When the system is ready to output start bit (0), it allows CLK go to active level. If

request-to-send is detected UT84520 clocks 11 bits. Following the tenth clock UT84520 checks for an active level on the DATA line, and if found, force

DATA low, and clock once more. If occurs framing error, UT84520 continue to clock until DATA is high, then clocks the line control bit and request a Resend. When the system sends out a command or data transmission that requires a response, the system waits for UT84520 to respond before sending its next output.

## D).PS/2 Mouse Error Handling

- a). A Resend command (FE ) following receipt of an invalid input or any input with incorrect parity
- b). If two invalid input are received in succession, an error code of hex (FC) is send to the system.
- c).The counter accumulators are cleared after receiving any command except "Resend".
- d). UT84520 receives a Resend command (FE),it transmit its last packet of data
- e). In the stream mode "Resend" is received by UT84520 following a 3-byte data packet transmission to the system. UT84520 resend the 3-byte data packet prior to clearing the counter.

- f). A response is sent within 25ms if
  - a). The system requires a response
  - b). An error is detected in the transmission
- g). UT84520 is in the stream mode
  - a). The system disables UT84520 before issuing any command requiring a response
  - b). When a command requiring a response is issued by the system, another command should not be issued until either the response is received or 25ms has passed.

E). PS/2 Mouse Command Description

There are 16 valid commands that transmit between the system and UT84520. The "FA" code is always the first response to any valid input received from the system other than a Set Wrap Mode or Resend command .

The following table lists the commands:

Hex Code	Command	UT84520 echo code
FF	Reset	FA,AA,00
FE	Resend	XX,(XX,XX)
F6	Set Default	FA
F5	Disable	FA
F4	Enable	FA
F3,XX	Set Sampling Rate	FA,FA
F2	Read Device Type	FA,00
F0	Set Remote Mode	FA
EE	Set Wrap Mode	FA
EC	Reset Wrap Mode	FA
EB	Read Data	FA,XX,XX,XX
EA	Set Stream Mode	FA
E9	Status Request	FA,XX,XX,XX
E8,XX	Set Resolution	FA,FA
E7	Set Auto-speed	FA
E6	Reset Auto-speed	FA

The following describes valid commands

- a). Reset (FF)
  - UT84520 operation:
    - a). Completion the reset
    - b). Transmitted FA, AA, 00 to the system.
  - c). Set default:
    - sampling rate: 100 reports/s
    - non-autospeed
    - stream mode
    - 2 dots/count
    - disable

b).Resend (FE)

- a). Any time UT84520 receives an invalid command, it returns a Resend command to the system.
- b). When UT84520 receives a Resend command, it retransmits its last packet of data. If the last packet was a Resend command, it transmits the packet just prior to the Resend command.
- c). In Stream mode, if a Resend command is received by UT84520 immediately following a 3-byte data packet transmission to the system

c). Set Default (F6)

The command initializes all condition to the Power-on defaults

d). Disable (F5)

This command is used in the stream mode to stop transmissions from UT84520

e). Enable (F4 )

Begins transmissions. If in stream mode.

f). Set Sampling Rate (F3,XX )

In the stream mode, this command sets the sampling rate to the value indicated by byte hex XX,

Shown in following:

Second byte XX	Sample Rate
0A	10/sec
14	20/sec
28	40/sec
3C	60/sec
50	80/sec
64	100/sec
C8	200/sec

g). Read Device Type (F2)

UT84520 always echoes "FA, 00" following this command

h). Set Remote Mode (F0)

Data value are reported only in response to a Read Data command

i). Set Wrap Mode (EE)

Wrap mode remains until Reset (FF) or Reset Wrap Mode (EC) is received

j).Reset Wrap Mode (EC)

UT84520 returns to the previous mode of operation after receiving this command

k). Read Data (EB )

This command is executed in either remote or stream mode. The data is transmitted even if there has been no movement since the last report or the button status is unchanged. Following a Read Data command, the registers are cleared after a data transmission.

l). Set Stream Mode (EA)

This commnd sets UT84520 in stream mode.

m). Status Request (E9)

When this command is issued by the system, UT84520 respond with a 3-byte status report as following:

Byte	Bit	Description
1	0	1 = Right button pressed
	1	1 = Middle button pressed
	2	1 = Left button pressed
	3	Reserved
	4	0 = Normal speed, 1 = Autospeed
	5	0 = Disabled, 1 = Enabled
	6	0 = Stream mode, 1 = Remote mode
2	7	Reserved
	0-7	Current resolution setting (D0 – D7)
3	0-7	Current sampling rate (D0 – D7)

n). Set Resolution (E8,XX)

UT84520 provides four resolutions selected by the second byte of this command as following:

Second Byte XX	Resolution
00	8 dots/count
01	4 dots/count
02	2 dots/count
03	1 dots/count

o). Set Autospeed (E7)

At the end of a sample interval in the stream mode, the current X and Y data values are converted new values.

The sign bits are not involved in this conversion. The conversion is only in stream mode. The relationship between the input and output count is as following:

Input	Output
0	0
1	1
2	1
3	3
4	6
5	9
$N \geq 6$	$2 * N$

p). Reset Autospeed (E6)

This command restore normal speed

(III). Microsoft PS/2 scrolling mouse mode:

(A) Entering procedure: Except in Wrap mode, while UT84520 received the following consecutive command:

- i. F3 C8 for set sampling rate 200/sec
- ii. F3 64 for set sampling rate 100/sec
- iii. F3 50 for set sampling rate 80/sec

## (B) Operation:

- a. All the commands in legacy mode are still valid.
- b. The ID code for Read Device Type command (F2) is changed from "00" to "03".
- c. Data report is changed to four byte format:

Byte	Bit	Description
1	0	Left button status; 1 = pressed
	1	Right button status; 1=pressed
	2	Middle button status; 1=pressed
	3	Reserve
	4	X data sign; 1=negative
	5	Y data sign; 1=negative
	6	X data overflow; 1=overflow
	7	Y data overflow; 1=overflow
2	0-7	X data (D0-D7)
3	0-7	Y data (D0-D7)
4	0-7	Z data (D0-D7)

## C) Exit for Microsoft scrolling mode:

There are two ways to exit:

- a. Power off
- b. Reset command (FF).

## (IV) Z-axis Input Function:

- (a). Photo couples input: Z-axis counter accumulates the Z1, Z2 phase changed by movement.
- (b). Mechanical mode: The same as optical wheel mode.

UTC assumes no responsibility for equipment failures that result from using products at values that exceed, even momentarily, rated values (such as maximum ratings, operating condition ranges, or other parameters) listed in products specifications of any and all UTC products described or contained herein. UTC products are not designed for use in life support appliances, devices or systems where malfunction of these products can be reasonably expected to result in personal injury. Reproduction in whole or in part is prohibited without the prior written consent of the copyright owner. The information presented in this document does not form part of any quotation or contract, is believed to be accurate and reliable and may be changed without notice.

Copyright © Each Manufacturing Company.

All Datasheets cannot be modified without permission.

This datasheet has been download from :

[www.AllDataSheet.com](http://www.AllDataSheet.com)

100% Free DataSheet Search Site.

Free Download.

No Register.

Fast Search System.

[www.AllDataSheet.com](http://www.AllDataSheet.com)