

UTC34119

LINEAR INTEGRATED CIRCUIT

LOW POWER AUDIO AMPLIFIER

DESCRIPTION

The UTC34119 is a low power audio amplifier integrated circuit intended (primarily) for the telephone applications, such as in speakerphones. It provides differential speaker outputs to maximize output swing at low supply voltages. Coupling Capacitor to the speaker are not required. Open loop gain is 80dB, and the closed loop gain is set with two external resistors. A chips Disable pin permits powering down and/or muting the input signal.

FEATURES

- *Wide operating supply voltage: $V_{cc}=2\sim 16V$
- *Low quiescent supply current($I_{cc}=2.7mA$, typical)
- *Medium output power
 $P_o=250mW$ at $V_{cc}=6V, R_L=32\Omega, Thd=10\%$
- *Load Impedance range(8 ohms to 100 ohm)
- *Low distortion
- *Mute function($I_{cc}=65\mu A$, typical)
- *Minimum number of external parts required.

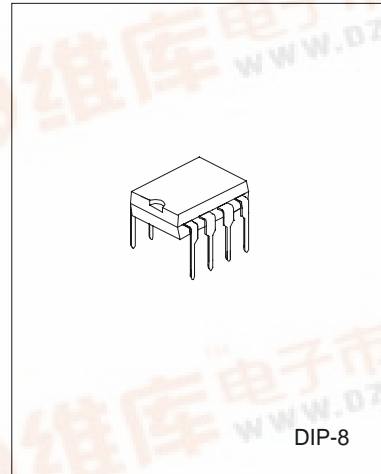

BLOCK DIAGRAM

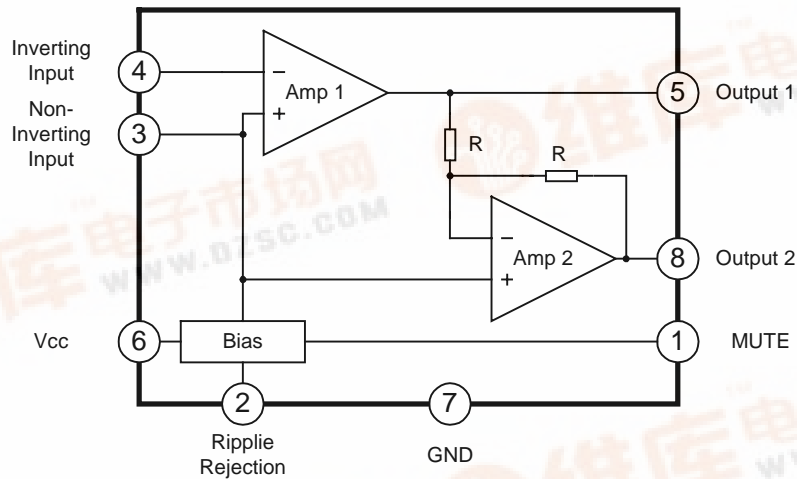

ABSOLUTE MAXIMUM RATINGS($T_a=25^{\circ}\text{C}$)

Characteristic	Symbol	Value	Unit
Supply Voltage	V _{cc}	-1.0~+18	V
Output Current	I _o	±250	mA
Maximum input ,ripple rejection, Mute pin voltage	V _{i(max)}	-1.0~V _{cc} +1.0	V
Applied output voltage(output pin when disabled)	V _o	-1.0~V _{cc} +1.0	V
Junction Temperature	T _j	-55 ~ +150	°C

PIN DESCRIPTION

Pin No.	Symbol	Description
1	Mute	This pin can be used to power down the IC to conserve power, or for muting, or both. When at a logic "LOW"(less than 0.8V), the IC is enabled for normal operation. When at a logic "HIGH"(2.0V ~V _{cc}), the IC is disabled. If Mute is open, that is equivalent to a logic "LOW".
2	Ripple Rejection	A capacitor at this pin increase power supply rejection, and affects turn-on time. This pin can be left open if the capacitor at pin 1 is sufficient.
3	Input(+)	Analog Ground for the amplifiers. A 1.0 μ F capacitor at this pin (with a 5.0 μ F capacitor at pin 8) provides 52dB(typical) of power supply rejection. Turn-on time of the circuit is affected by the capacitor on this pin. This pin can be used as an alternative input.
4	input(-)	Amplifier input. The input capacitor and resistor set low frequency roll-off and input impedance. The feedback resistor is connected between this pin and output 1.
5	Output 1	Amplifier a's output. The DC level is about (V _{cc} -0.7V)/2.
6	V _{cc}	DC supply voltage is applied to this pin(V _{cc} =2.0V ~16.0V)
7	GND	Ground pin
8	Output 2	Amplifier 2's output. This signal is equal in amplitude, but 180° out of phase with that t output 1 the DC level is about(V _{cc} -0.7V)/2.

RECOMMENDED OPERATION CONDITIONS($T_a=25^{\circ}\text{C}$)

Characteristics	Symbol	Min	Typ	Max	Unit
Supply Voltage	V _{cc}	2.0		16	V
Load Impedance	Z _L	8		100	Ω
Peak Load Current	I _{L(peak)}			±200	mA
Differential Gain(5kHz Bandwidth)	ΔG _v	0		46	dB
Voltage at Mute	V _{i(mute)}	0		V _{cc}	V
Ambient temperature	T _a	-20		470	°C

UTC34119

LINEAR INTEGRATED CIRCUIT

ELECTRICAL CHARACTERISTICS

(Ta=25°C, Vcc=6V, unless otherwise specified)

Characteristic	Symbol	Test Conditions	Min	Typ	Max	Units
DC Characteristics						
Operating current	Icc	Vcc=3.0V, Mute=0.8V		2.7	4.0	mA
		Vcc=16.0, Mute=0.8V		3.3	5.0	mA
		Vcc=3.0V, Mute=2.0V		65	100	μA
Output Voltage	Vo	RL=16Ω, R1=75kΩ				V
		Vcc=3.0V	1.0	1.15	1.25	
		Vcc=6.0V		2.65		
		Vcc=12.0V		5.65		
Output Offset Voltage	Voo	Vcc=6.0V, Rf=75kΩ, RL=32Ω	-30	0	+30	mV
Output High Level	VOH	2.0V<Vcc<16V, Iout=-75mA		Vcc-1.0		V
Output Low Level	VOL	2.0V<Vcc<16V, Iout=75mA		0.16		V
Input Bias Current	Ibias			-100	-200	nA
Equivalent Resistance	REQ	pin1	100	150	220	kΩ
		pin8	18	25	40	
AC Characteristics						
Open Loop Gain of Amp 1	Gv1		80			dB
Open Loop Gain of Amp 2	Gv2	f=1.0kHz, RL=32Ω	-0.35	0	0.35	dB
Output Power	Po	Vcc=3.0V, RL=6Ω, THD<10%	55			mW
		Vcc=6.0V, RL=32Ω, THD<10%	250			
		Vcc=12.0V, RL=100Ω, THD<10%	400			
Total Harmonic Distortion (f=1.0kHz)	THD	Vcc=6.0V, RL=32Ω, Po=125mW		0.5	1.0	%
		Vcc<3.0V, RL=8Ω, Po=20mW		0.5		
		Vcc<12V, RL=32Ω, Po=200mW		0.6		
Gain Bandwidth Product	GBW			1.5		MHz
Power Supply rejection (Vcc=6.0V, ΔVcc=3.0V)	PSRR	C1=∞, C2=0.01μF	50			dB
		C1=0.1μF, C2=0, f=1kHz,		12		
		C1=1.0μF, C2=5.0μF, f=1kHz		52		
Muting	Gv(mute)	Mute=2.0V, 1.0kHz<f<20kHz	70			dB

TYPICAL APPLICATION CIRCUIT

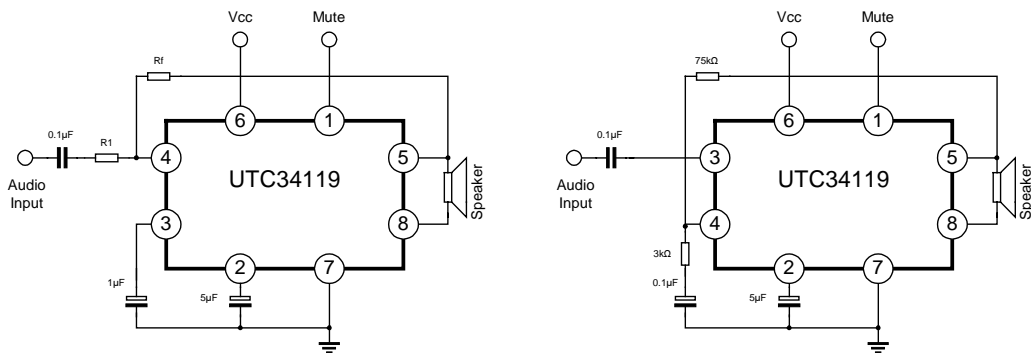

UTC34119

LINEAR INTEGRATED CIRCUIT

