

UTC8227

LINEAR INTEGRATED CIRCUIT

LOW FREQUENCY POWER AMPLIFIER

DESCRIPTION

The UTC8227 is the audio power amplifier with built-in two channel developed for portable radio cassette tape recorder with power ON/OFF switch.

FEATURES

- *Wide operating supply voltage: $V_{cc}=5-12V$
- *Low quiescent supply current
($I_{cc}=21mA$, typical, at $V_{cc}=9V, V_i=0$)
- *Output power
 $P_o=2.50W/CH$ at $V_{cc}=9V, R_L=4\Omega, f=1kHz, Thd=10\%$
- *Soft Clip
- *Built-in Thermal shut-down protection circuit
- *Stand-by Switch

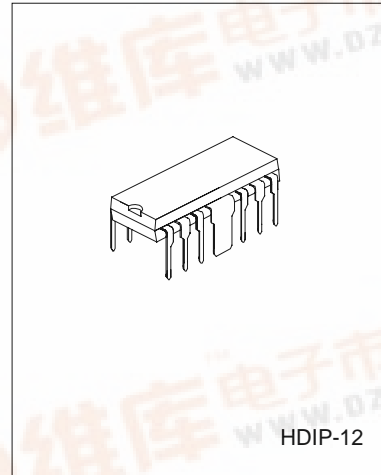

TEST CIRCUIT

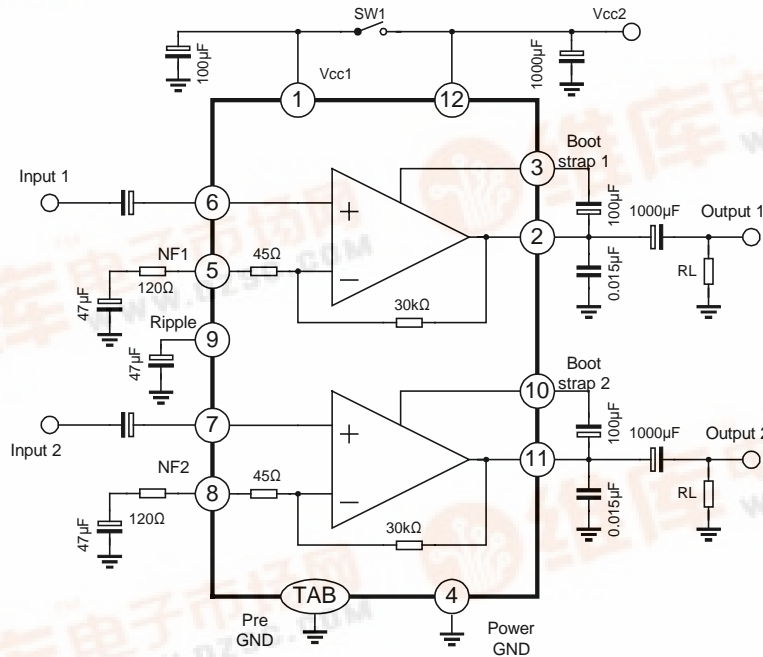

ABSOLUTE MAXIMUM RATINGS($T_a=25^{\circ}\text{C}$)

Characteristic	Symbol	Value	Unit
Supply Voltage	Vcc	20	V
Output Current	Io	2.5	A
Power Dissipation(note)	Pd	4	W
Operating Temperature	Topr	-20 ~ +75	$^{\circ}\text{C}$
Storage Temperature	Tstg	-55 ~ +150	$^{\circ}\text{C}$

Note: Value for mounting on PC board

ELECTRICAL CHARACTERISTICS

($T_a=25^{\circ}\text{C}$, $V_{cc}=9\text{V}$, $R_L=4\Omega$, $R_g=600\Omega$, $f=1\text{kHz}$, unless otherwise specified)

Characteristic	Symbol	Test Conditions	Min	Typ	Max	Units
Quiescent current	Icc	$V_i=0$		21	45	mA
Output Power	Po	THD=10%, $R_L=4\Omega$	2.0	2.5		W
		THD=10%, $R_L=3\Omega$		3.0		W
Total Harmonic Distortion	THD	$P_o=0.4\text{W}/\text{CH}$		0.2	1.0	%
Voltage Gain	Gv1	$R_f=120\Omega$, $V_{out}=0.775\text{V}_{rms}$	43	45	47	dB
	Gv2	$R_f=0$, $V_{out}=0.775\text{V}_{rms}$		56.5		
Input Impedance	Rin			30		Ω
Output Noise Voltage	Vno	$R_g=10\text{k}\Omega$, $\text{BW}=20\text{Hz}\sim 20\text{kHz}$		0.3	1.0	mVrms
Ripple Rejection Ratio	R.R	$R_g=600\Omega$, $f_{ripple}=100\text{Hz}$		52		dB
Cross Talk	C.T	$R_g=600\Omega$, $V_{out}=0$, $f=1\text{kHz}$		50		dB
Input Offset Voltage	V7,8			30	60	mV
Standby Current		Sw1:OFF		1		μA

TYPICAL PERFORMANCE CHARACTERISTICS

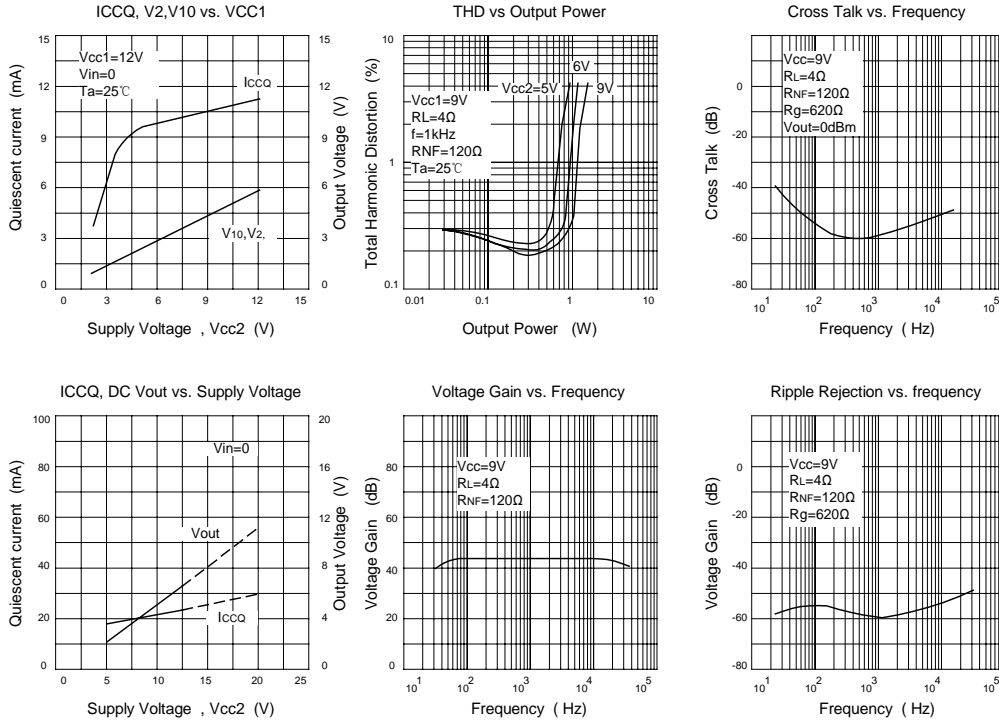

APPLICATION INFORMATION

1. Input Voltage

When the excessive signal is input, turning-up is produced in the clip waveform. The turning-up point is $V_{in}=300mV_{rms}$ (Typical) at $V_{cc}=9V, R_L=4\Omega, f=1kHz$. Enough care must be taken for this phenomenon.

2. Power ON/OFF

There is power ON/OFF switch at pin 1. However output power is changed by pin 1 supply voltage when pin1 supply voltage is not same pin 12 supply voltage, after referring to attached date, select pin 1 supply voltage.

3. Voltage Gain

The voltage gain can be changed by the external negative feedback resistor. When $R_f=0$, the Gain is equal to 56.5dB. When $R_f=120\Omega$, the Gain is equal to 45dB.