

UTCAN5151 LINEAR INTEGRATED CIRCUIT

TV VIF & SIF & DEFLECTION SYSTEM (FOR TV LARGE INTEGRATION)

DESCRIPTION

The UTC AN5151 is a monolithic integrated circuit containing all stage for the VIF,SIF and deflection of television receivers.

FEATURES

- *High integrated technology makes it possible the integration of video IF circuit tuner AFC circuit sound. IF circuit and deflection-jungle circuit on one single chip.
- *supply voltage range:8V to 12V

FUNCTIONS

- *IF Amplifier, IF AGC
- *Video Amplifier, Video Detector
- *Noise Canceller, Forward RF AGC
- *Tuner AFT,SIF Amplifier
- *Sound Detector, sync separation
- *Vertical oscillation trigger and driver
- *Horizontal oscillation driver and AFC

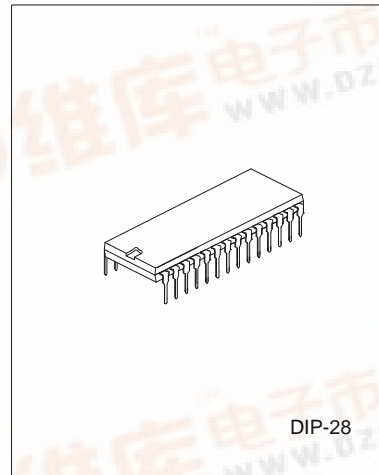

TYPICAL APPLICATION CIRCUIT

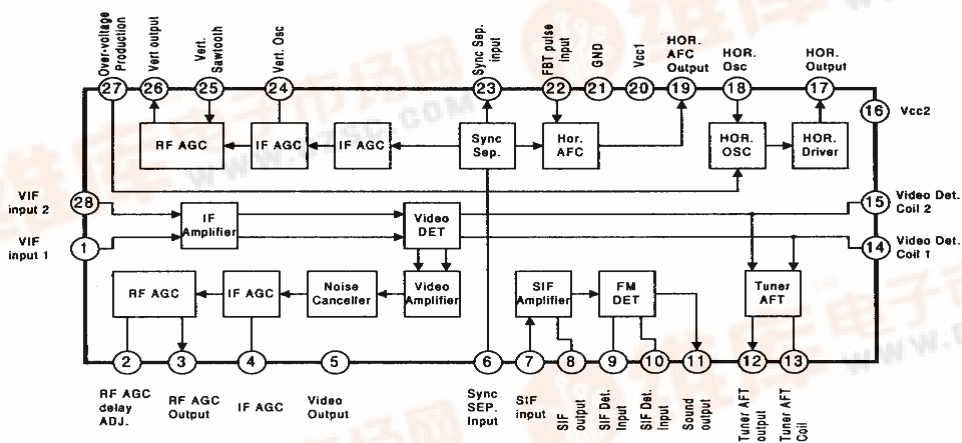

UTCAN5151 LINEAR INTEGRATED CIRCUIT

ABSOLUTE MAXIMUM RATINGS (Ta=25°C)

PARAMATER	SYMBOL	VALUE	UNIT
Supply Voltage	Vcc1	12	V
Supply Current	I20	85	mA
	I16	15	mA
Circuit Voltage	V2,3,4,24	0	V
	V8	5.5 ~ 0	V
	V13	4.2 ~ 0	V
	V17	0	V
Circuit Current	I5,6,11,23,26	+0.3 ~ -10	mA _{p-p}
	I19	+0.6 ~ -0.6	mA _{p-p}
	I25	+10 ~ 0	mA _{p-p}
	I17	+10 ~ -4	mA _{p-p}
Operating Temperature	T _{opr}	-20 to +70	°C
Storage Temperature	T _{stg}	-40 to 125	°C
Power Dissipation(Ta=70°C)	P _{D1}	1100	mW

ELECTRICAL CHARACTERISTICS

(Ta=25°C, Vcc=10V, Vcc2=9.5V, unless otherwise specified)

PARAMATER	SYMBOL	TEST CONDITION	MIN	TYP	MAX	UNIT
VIDEO SECTION						
Video Det. Output	V _o	m=87.5%	2.0	2.3	2.6	V _{p-p}
Input Sensitivity	S _{vi}	V _o =-3dB		50	55	dB _μ
Maximum Input	V _{max}	V _o >+0dB	105	110		dB
S/N Ratio	S/N	V _i =80dB _μ	51	56		dB
Differential Gain	DG	m=87.5%		4	8	%
Differential Phase	DP	m=87.5%		3	6	°C
Video frequency Characteristics	G _{vf}	V _o =-3dB	4.5	6.0	8.0	MHz
Sync. Peak Voltage	V _p		1.9	2.3	2.7	V
Noise inverter output level	V _{NT}		1.0	1.4	1.8	V
Noise inverter capture level	V _{NI}		3.0	4.0	5.0	V
Sound IF Output	V _{sif}	P/S=20dB	100	104	107	dB _μ
Input Resistor	R _{in}	f=45.75MHz	0.8	1.0	1.2	kΩ
Input Capacitor	C _{in}	f=45.75MHz	3.0	3.4	3.8	pF
Output Resistor	R _o (pin 5)	f=500kHz	30	50	150	Ω
RF AGC Gain	G _{RF} (AGC)	f=10kHz, V ₄ =5mV	36	42	48	dB
RF AGC Maximum Voltage	V ₃ (max)		8.2	8.8	9.4	V
RF AGC Minimum Voltage	V ₃ (min)		3.6	4.2	4.8	V
AFT Center Voltage	V ₂		4.0	5.4	6.0	V

UTC AN5151 LINEAR INTEGRATED CIRCUIT

PARAMATER	SYMBOL	TEST CONDITION	MIN	TYP	MAX	UNIT
AFT SW Operating Voltage	$V_{AFT(SW)}$	$R_s=10k\Omega$	0.5	2.6	3.0	V
AFT Maximum Output Voltage	V12 (max)		8.5	9.6	10.0	V
AFT Minimum Output Voltage	V12 (min)		0	0.7	1.2	V
Selection Sensitivity		$R_L=68k\Omega/82k\Omega$	30	50	90	mV/kHz
SOUND SECTION						
Sound Det. Output	V_o	$f_o=4.5MHz, f_m=400Hz, \Delta f=+25kHz, V_i=100mVrms$	200	300	440	mVrms
Input Limit Voltage	$V_i (lim)$	$f_o=4.5MHz, f_m=400Hz, \Delta f=+25kHz$		280	450	$\mu Vrms$
Total Harmonic distortion	THD	$f_o=4.5MHz, f_m=400Hz, \Delta f=+25kHz, V_i=100mVrms$		0.6	1.0	%
AM Rejection ratio	AMR	$f_o=4.5MHz, f_m=400Hz, \Delta f=+25kHz, V_i=100mVrms$	43	55		dB
Input Impedance	R17	$f=4.5MHz$	6	20	100	$k\Omega$
	C17		1.3	4.3	7.3	pF
Detector input impedance	R9	$f=4.5MHz$	2.0	3.0	4.0	$k\Omega$
	C9		2.1	5.1	8.1	pF
	R10		50	200		$k\Omega$
	C10		2.9	3.4	3.9	pF
DEFLECTION SECTION						
Sync separation horizontal pulse width 1	tsYNC1	Video input 2.5Vp-p APL=50%, $V_{cc1}=10V$	4.8	5.1	5.4	μs
Sync separation horizontal pulse width 2	tsYNC2	Video input 1.0Vp-p APL=50%, $V_{cc1}=10V$	4.9	5.2	5.5	μs
Horizontal AFC Horizontal pulse width 1	tsYNC3	Video input 2.5Vp-p APL=50%, $V_{cc1}=10V$	4.8	5.1	5.4	μs
Horizontal AFC Horizontal pulse width 2	tsYNC4	Video input 1.0Vp-p APL=50%, $V_{cc1}=10V$	4.9	5.2	5.5	μs
Vertical Osc. start supply voltage	V_{vos}	$f_{vo}=50\sim 70Hz, Output=0.7Vp-p$			6	V
Vertical free runing frequency	f_{vo}	$R_{osc}=31.5k\Omega$	57	60	63	Hz
Vertical Osc. Pulse width	tvo	$R_{osc}=31.5k\Omega$	470	650	830	μs
Vertical full in Range	$f_v(pull)$	$V_{cc1}=12V, 8V$ $\Delta f_{vo}/V_{cc}=f_{vo}(12V)-f_{vo}(8V)$	0	1.0	1.3	Hz
Horizontal OSC. Start supply voltage	V_{hos}	$f_{ho}=10\sim 20kHz, output=1Vp-p$ pin 16 Voltage			5	V
Horizontal Osc. Frequency	f_{ho}	$R_{osc}=21k\Omega$	15.0	15.75	16.25	kHz
Horizontal Osc. Pulse width	t _{ho}	$R_{osc}=21k\Omega$	23	25	29	μs
Horizontal OSC Control Sensitivity		$\Delta I_1=+100\mu A$ input Variable Osc. Frequency Variable	73	81	89	Hz/ μA
Phase Det. Sensitivity	μP	TV input 2Vp-p, $R(u)=31.4k\Omega, \mu=V19*10$	13.5	16.5	19.5	$\mu A/\mu S$

UTCAN5151 LINEAR INTEGRATED CIRCUIT

PARAMATER	SYMBOL	TEST CONDITION	MIN	TYP	MAX	UNIT
X-ray protector operation voltage	V27		0.81	0.87	0.93	V
X-ray protector input resistor	R27		16	19	22.5	k Ω