

UTCLAG665F LINEAR INTEGRATED CIRCUIT

RADIO AND CASSETTE RECORDER CIRCUIT

DESCRIPTION

The UTC LAG665F is a monolithic integrated circuit, designed for portable radio cassette.

FEATURES

- *1-Chip stereo tape recorder with motor speed controller.
- *Operating supply voltage range: $V_{cc}=2-5V$
- *Good volume control

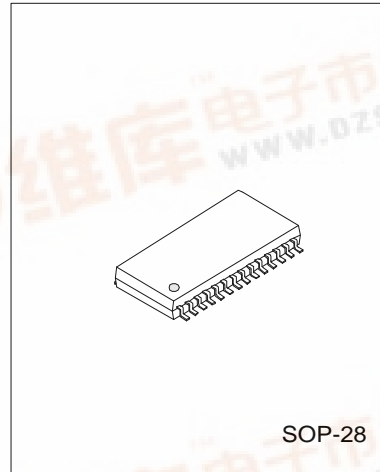

BLOCK DIAGRAM

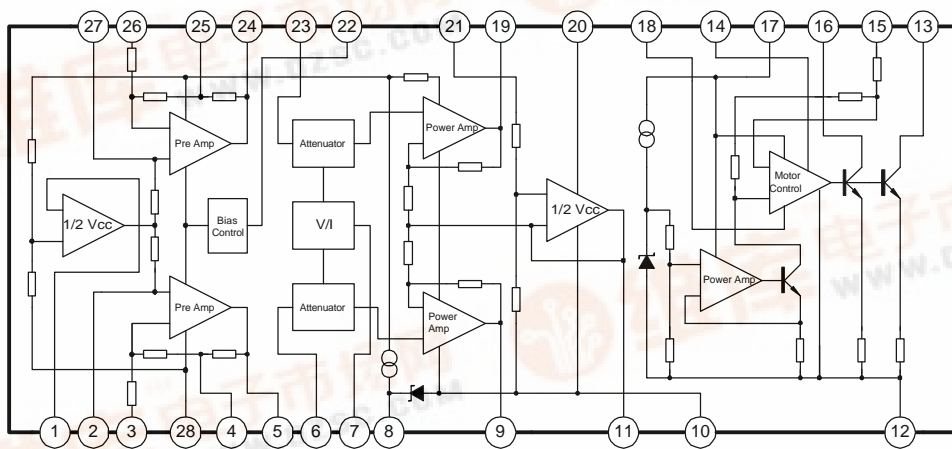

UTCLAG665F LINEAR INTEGRATED CIRCUIT

PIN CONFIGURATION

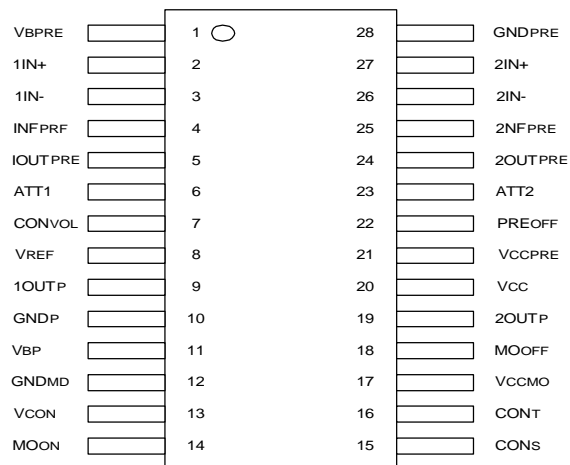

PIN NO.	SYMBOL	DESCRIPTION	PIN NO.	SYMBOL	DESCRIPTION
1	VBP	Pre Amp Bias Voltage	15	CONS	Speed Control
2	1 IN+	Channel 1 "+" Input	16	CONT	Torqu Control
3	1 IN -	Channel 1 "-" Input	17	VCCMO	Motor Power Control
4	1 NFPRF	Feedback 1	18	MOOFF	Motor Forced Stop
5	1 OUTPRE	Pre Amp Output 1	19	2 OUTP	Power Amp Output 2
6	ATT 1	Attenuator 1	20	VCC	Supply Voltage
7	CONVOL	Volume Control	21	VCCPRE	Supply Voltage
8	VREF	Reference Voltage	22	PREOFF	Pre Amp Off
9	1 OUTP	Power Amp Output 1	23	ATT 2	Attenuator 2
10	GNDP	Power GND	24	2 OUTPRE	Pre Amp Output 2
11	VBP	Power Amp Bias Voltage	25	2 NFPRE	Feedback 2
12	GNDMD	Motor GND	26	2 IN-	Channel 2 "-" Input
13	VCON	Motor Control Voltage	27	2 IN+	Channel 2 "+" Input
14	MOON	Motor Forced Start	28	GNDPRE	Pre GND

UTCLAG665F LINEAR INTEGRATED CIRCUIT

ABSOLUTE MAXIMUM RATINGS(Ta=25°C)

PARAMETER	SYMBOL	VALUE	UNIT
Supply Voltage	Vcc	-0.3~+7.5	V
Power Dissipation	Pd	450	mW
Operating Voltage	Vop	2~5	V
Operating Temperature	Topr	-20~+65	°C
Storage Temperature	Tstg	-40~+125	°C

ELECTRICAL CHARACTERISTICS(Ta=25°C, Vcc=3V, f=1kHz, RL=16Ω, unless otherwise specified)

PARAMETER	SYMBOL	TEST CONDITIONS	MIN	TYP	MAX	UNIT
Supply Current	Icc	Vin=0V, Im=0mA		18	25	mA
PRE-AMPLIFIER						
Open Loop Gain	Gvo	Vo=-10dBm, RL=∞		72		dB
Close Loop Gain	Gvc	Vo=-10dBm	40	42	44	dB
Maximum Output Voltage	Vom	THD=10%	0.45	0.6		Vrms
Total Harmonic Distortion	THD	Vout=100mVrms		0.05	0.5	%
Output Noise Voltage	Von	Vin=0, Rg=2.2k, BPF(30~20k)		150	300	μVrms
Input Impedance	Zin	Vout=-10dBm	18	22		kΩ
Cross Talk between CH	CT	Rg=2.2k, Vout=-10dBm	30			dB
Pre Amp						
Output Voltage when Pre-Off	Vooff	Vin=100mVrms			-50	dB
Output Impedance when Pre-Off	Rooff			10		kΩ
Input Impedance when Pre-Off	Rioff			10		kΩ
Attenuator						
Maximum Input Voltage	Vimax		0.2			Vrms
Maximum Attenuation	Vamax	Vcont=Min	66			dB
Attenuation Error	Vaerr	Vcont=Max		0		dB
Input Impedance	Zia		15	20		kΩ
Control Terminal Input Impedance	Zicot		100			kΩ
Power Amplifier						
Voltage Gain	GV	Pout=5mW	26	28	30	dB
Channel Voltage Difference	ΔGV	Vcont=Max		0	3	dB
Maximum Output Power I	Pom 1	THD=10%, RL=32Ω	20	28		mW
Maximum Output Power II	Pom 2	THD=10%, RL=16Ω	30			mW
Total Harmonic Distortion	THD	Pout=5mW		0.2	2	%
Cross Talk between CH	CT	Pout=5mW	20	30		dB
Output Noise Voltage	Von	Rg=2.2k, Vcont=Min		0.25	1	mVrms
Ripple Rejection	RR	Vcc=3V, 100Hz, 100mVp-p	34	40		dB
Pre + Pulse Boost + Power Noise	Vnto	Vin=0V, Rg=2.2k, Vcont=Max*		6	9	mVrms
Motor *Vcc=3V, Im=100mA						
Current Consumption	IMC			3	5	mA
Starting Current	IMS		500			mA
Reference Voltage	Vref	Pin 15~Pin 16	0.72	0.8	0.87	V

UTC LAG665F LINEAR INTEGRATED CIRCUIT

PARAMETER	SYMBOL	TEST CONDITIONS	MIN	TYP	MAX	UNIT
Reference Voltage Change I	Vref 1	V _{cc} =2.1~5V		0.05		%/V
Reference Voltage Change II	Vref 2	I _m =25~250mA		0.01		%/mA
Reference Voltage Change III	Vref 3	T _a =-10~50°C		0.01		%/°C
Current Factor	K		32	38	43	
Current Factor Change I	K 1	V _{cc} =2.1~5V		0.5		%/V
Current Factor Change II	K 2	I _m =25~250mA		0.05		%/mA
Current Factor Change III	K 3	T _a =-10~50°C		0.02		%/°C
Saturation Voltage at Forced ON	VCEsa	I _M =200mA, Pin 14=V _{cc}			0.6	V
Input Impedance at Forced ON Pin	R _{ion}			5.6		KΩ
Leakage Current at Forced OFF	I _{ML}				200	μA
Input Impedance at Forced OFF Pin	R _{icon}			33		KΩ

TEST CIRCUIT

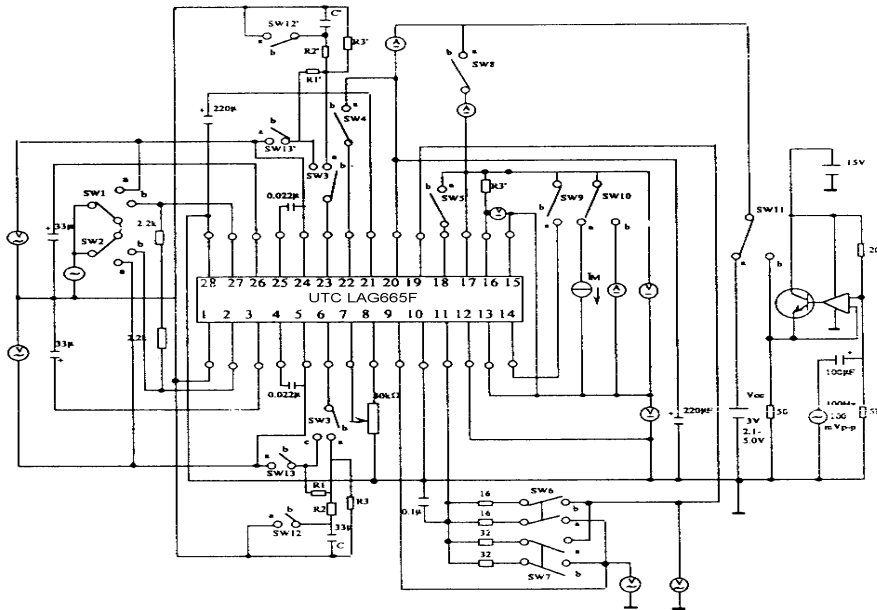

NOTE1 : SW12, SW12
R1, R1' = 33kΩ
R2, R2' = 5.1kΩ
R3, R3' = 200kΩ
R2, R2, = 5.1kΩ
C1, C' = 0.1μF

NOTE2 : See figure 1 for SW

UTCLAG665F LINEAR INTEGRATED CIRCUIT

FIGURE 1

Item	Symbol	SW No.											TEST CONDITION
		1	2	3,3'	4	5	6	7	8	9	10	11	
AMP													
Supply Current	ICC	c	c	a	b	b	a	b	b	b	a	a	
Close Loop Gain	Gvc	b	b	b	b	b	a	b	b	b	a	a	Im=0mA
Maximum Output Voltage	Vom	b	b	b	b	b	a	b	b	b	a	a	V _o =244mV
Total Harmonic Distortion	THD	b	b	b	b	b	a	b	b	b	a	a	V _o =400mV
Output Noise Voltage	Von	c	c	b	b	b	a	b	b	b	a	a	B.P.F.(30-20kHz)
Cross Talk between CH	CT	b/	c/	b	b	b	a	b	b	b	a	a	V _o =244mV
		c	b										
Output Voltage when Pre-Off	Vooff	b	b	b	a	b	a	b	b	b	a	a	V _{in} =100mV
Attenuator													
Maximum Input Voltage	Vimax	a	a	a	a	b	a	b	b	b	a	a	V _r =Min, THD=10%,
Maximum Attenuation	Vamax	a	a	a	a	b	a	b	b	b	a	a	
Power AMP													
Voltage Gain	GV	a	a	a	a	b	a	b	b	b	a	a	P _{out} =5mV
Channel Voltage Difference	ΔGV	a	a	a	a	b	a	b	b	b	a	a	V _R =MAX
Maximum Output Power I	Pom 1	a	a	a	a	b	b	a	b	b	a	a	R _L =32Ω, THD=10%
Maximum Output Power II	Pom 2	a	a	a	a	b	a	b	b	b	a	a	R _L =16Ω, THD=10%