

MOSEL VITELIC **V53C104F**
HIGH PERFORMANCE, LOW POWER
256K X 4 BIT FAST PAGE MODE
CMOS DYNAMIC RAM

HIGH PERFORMANCE V53C104F	60/60L	70/70L	80/80L
Max. $\overline{\text{RAS}}$ Access Time, (t_{RAC})	60 ns	70 ns	80 ns
Max. Column Address Access Time, (t_{CAA})	30 ns	35 ns	40 ns
Min. Fast Page Mode Cycle Time, (t_{PC})	40 ns	45 ns	50 ns
Min. Read/Write Cycle Time, (t_{RC})	120 ns	130 ns	150 ns

LOW POWER V53C104FL	60L	70L	80L
Max. CMOS Standby Current, (I_{DD6})	200 μA	200 μA	200 μA

Features

- 256K x 4 Organization
- RAS access time: 60,70,80 ns
- Low power dissipation for V53C104F-80
 - Operating Current – 70 mA max.
 - TTL Standby Current – 2.0 mA max.
- Low CMOS Standby Current
 - V53C104F – 1.0 mA max.
 - V53C104FL – 0.2 mA max.
- Read-Modify-Write, $\overline{\text{RAS}}$ -Only Refresh, $\overline{\text{CAS}}$ -Before- $\overline{\text{RAS}}$ Refresh capability.
- Common I/O capability
- Refresh Interval
 - V53C104F – 512 cycles/8ms
 - V53C104FL – 512 cycles/64ms
- Fast Page Mode for a sustained data rate greater than 25 MHz
- Standard packages are 20 pin Plastic DIP and 26/20 pin SOJ
- Low Battery Back-up Current
 - V53C104FL – 300 μA max.
 - 200 μA max. available on request

Description

The V53C104F is a high speed 262,144 x 4 bit CMOS dynamic random access memory. The V53C104F offers a combination of features: Fast Page Mode for high data bandwidth, fast usable speed, CMOS standby current and, on request, extended refresh for very low data retention power (V53C104FL).

All inputs and outputs are TTL compatible. Input and output capacitances are significantly lowered to allow increased system performance. Fast Page Mode operation allows random access of up to 512 (x4) bits within a row with cycle times as short as 40 ns. Because of static circuitry, the $\overline{\text{CAS}}$ clock is not in the critical timing path. The flow-through column address latches allow address pipelining while relaxing many critical system timing requirements for fast usable speed. These features make the V53C104F ideally suited for graphics, digital signal processing and high performance computing systems.

The V53C104FL offers a maximum data retention power of 1.65 mW when operating in CMOS standby mode and performing $\overline{\text{CAS}}$ -before- $\overline{\text{RAS}}$ refresh cycles.

Device Usage Chart

Operating Temperature Range	Package Outline		Access Time (ns)			Power		Temperature Mark
	P	K	60	70	80	Low	Std.	
0°C to 70°C	•	•	•	•	•	•	•	Blank

Description	Pkg.	Pin Count
Plastic DIP	P	20
SOJ	K	26/20

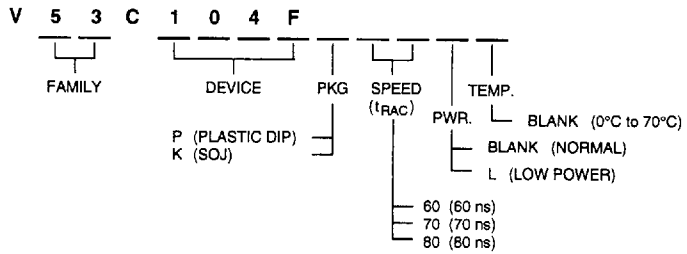

**26/20 Lead SOJ Package
PIN CONFIGURATION
Top View**

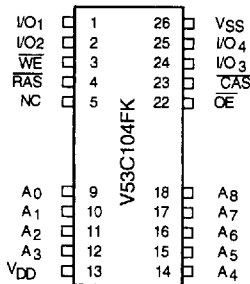

**20 Lead Plastic DIP
PIN CONFIGURATION
Top View**

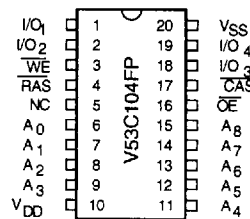

2

Pin Names

A ₀ -A ₃	Address Inputs
RAS	Row Address Strobe
CAS	Column Address Strobe
WE	Write Enable
OE	Output Enable
I/O ₁ -I/O ₄	Data Input, Output
V _{DD}	+5V Supply
V _{SS}	0V Supply
NC	No Connect

Absolute Maximum Ratings*

Ambient Temperature	
Under Bias	-10°C to +80°C
Storage Temperature (plastic)	-55°C to +125°C
Voltage Relative to V _{SS}	-1.0 V to +7.0 V
Voltage on V _{DD} relative to V _{SS}	-1.0 V to +7.0 V
Data Output Current	50 mA
Power Dissipation	1.0 W

*Note: Operation above Absolute Maximum Ratings can adversely affect device reliability.

V53C104F Rev. 1.0 January 1995

Capacitance*

T_A = 25°C, V_{DD} = 5 V ± 10%, V_{SS} = 0 V

Symbol	Parameter	Typ.	Max.	Unit
C _{IN1}	Address Input	—	6	pF
C _{IN2}	RAS, CAS, WE, OE	—	7	pF
C _{OUT}	Data Input/Output	—	7	pF

* Note: Capacitance is sampled and not 100% tested

Block Diagram

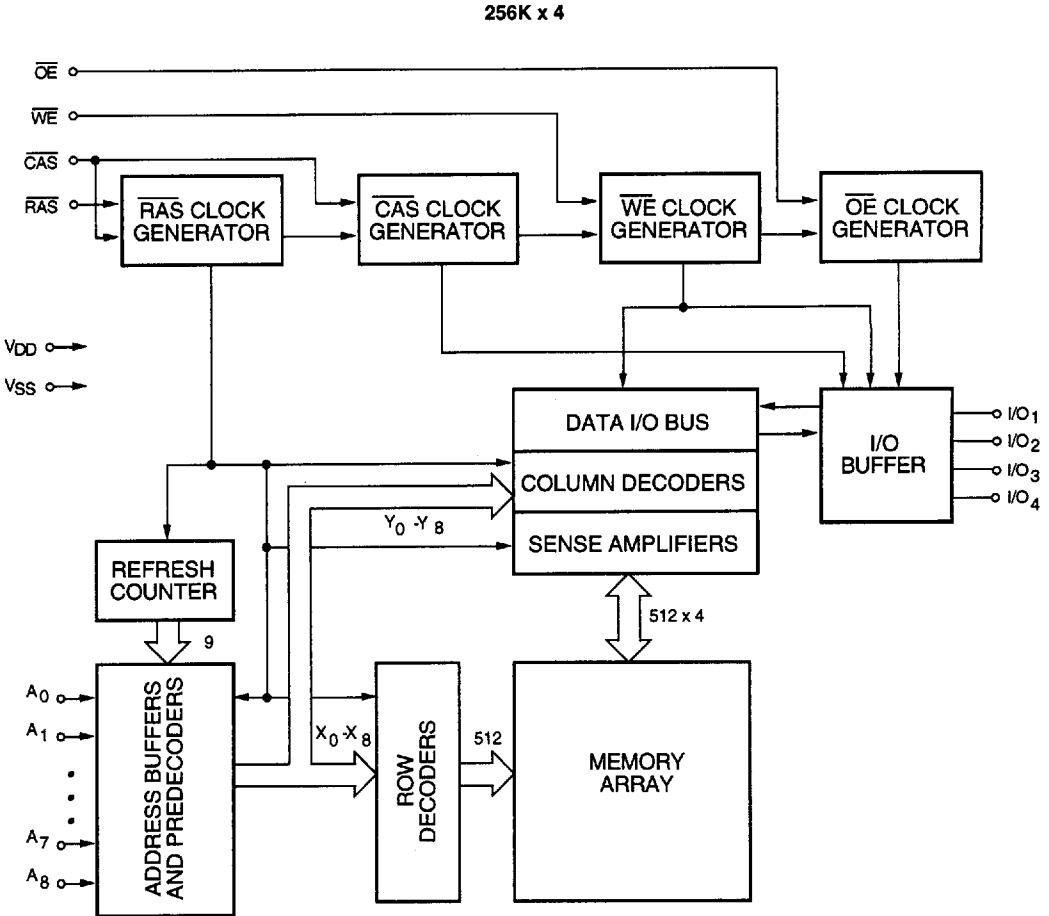

DC and Operating Characteristics (1-2)

$T_A = 0^\circ\text{C}$ to 70°C , $V_{DD} = 5\text{ V} \pm 10\%$, $V_{SS} = 0\text{ V}$, unless otherwise specified.

Symbol	Parameter	Access Time	V53C104F		V53C104FL		Unit	Test Conditions	Notes
			Min.	Max.	Min.	Max.			
I_{LI}	Input Leakage Current (any input pin)		-10	10	-10	10	μA	$V_{SS} \leq V_{IN} \leq V_{DD}$	
I_{LO}	Output Leakage Current (for High-Z State)		-10	10	-10	10	μA	$V_{SS} \leq V_{OUT} \leq V_{DD}$ RAS, CAS at V_{IH}	
I_{DD1}	V_{DD} Supply Current, Operating	60		90		90	mA	$t_{RC} = t_{RC}(\text{min.})$	1, 2
		70		80		80			
		80		70		70			
I_{DD2}	V_{DD} Supply Current, TTL Standby			2.0		2.0	mA	RAS, CAS at V_{IH} other inputs $\geq V_{SS}$	
I_{DD3}	V_{DD} Supply Current, RAS-Only Refresh	60		90		90	mA	$t_{RC} = t_{RC}(\text{min.})$	2
		70		80		80			
		80		70		70			
I_{DD4}	V_{DD} Supply Current, Fast Page Mode Operation	60		80		80	mA	Minimum Cycle	1, 2
		70		70		70			
		80		60		60			
I_{DD5}	Standby, Output Enabled			3.0		2.0	mA	$\overline{\text{RAS}} = V_{IH}$, $\overline{\text{CAS}} = V_{IL}$ other inputs $\geq V_{SS}$	1
I_{DD6}	V_{DD} Supply Current CMOS Standby			1.0		0.2	mA	$\overline{\text{RAS}} \geq V_{DD} - 0.2\text{ V}$, $\overline{\text{CAS}} \geq V_{DD} - 0.2\text{ V}$ other input $\geq V_{SS}$	
V_{IL}	Input Low Voltage		-1.0	0.8	-1.0	0.8	V		3
V_{IH}	Input High Voltage		2.4	$V_{DD}+1$	2.4	$V_{DD}+1$	V		3
V_{OL}	Output Low Voltage			0.4		0.4	V	$I_{OL} = 4.2\text{ mA}$	
V_{OH}	Output High Voltage		2.4		2.4		V	$I_{OH} = -5\text{ mA}$	

2

AC Characteristics

$T_A = 0^\circ\text{C}$ to 70°C , $V_{DD} = 5\text{ V} \pm 10\%$, $V_{SS} = 0\text{V}$ unless otherwise noted

AC Test conditions, input pulse levels 0 to 3V

#	JEDEC Symbol	Symbol	Parameter	60/L		70/L		80/L		Unit	Notes
				Min.	Max.	Min.	Max.	Min.	Max.		
1	t_{RL1RH1}	t_{RAS}	RAS Pulse Width	60	75K	70	75K	80	75K	ns	
2	t_{RL2RL2}	t_{RC}	Read or Write Cycle Time	120		130		150		ns	
3	t_{RH2RL2}	t_{RP}	RAS Precharge Time	50		50		60		ns	
4	t_{RL1CH1}	t_{CSH}	CAS Hold Time	60		70		80		ns	
5	t_{CL1CH1}	t_{CAS}	CAS Pulse Width	15		20		20		ns	
6	t_{RL1CL1}	t_{RCD}	RAS to CAS Delay	20	45	20	50	20	60	ns	4
7	t_{WH2CL2}	t_{RCS}	Read Command Setup Time	0		0		0		ns	
8	t_{AVRL2}	t_{ASR}	Row Address Setup Time	0		0		0		ns	
9	t_{RL1AX}	t_{RAH}	Row Address Hold Time	10		10		10		ns	
10	t_{AVCL2}	t_{ASC}	Column Address Setup Time	0		0		0		ns	
11	t_{CL1AX}	t_{CAH}	Column Address Hold Time	15		15		15		ns	
12	$t_{CL1RH1(R)}$	$t_{RSH(R)}$	RAS Hold Time (Read Cycle)	15		20		20		ns	
13	t_{CH2RL2}	t_{CRP}	CAS to RAS Precharge Time	5		5		5		ns	
14	t_{CH2WX}	t_{RCH}	Read Command Hold Time Referenced to CAS	0		0		0		ns	5
15	t_{RH2WX}	t_{RRH}	Read Command Hold Time Referenced to RAS	0		0		0		ns	5
16	$t_{OEL1RH2}$	t_{ROH}	RAS Hold Time Referenced to OE	10		10		10		ns	
17	t_{GL1QV}	t_{OAC}	Access Time from OE		15		20		20	ns	
18	t_{CL1QV}	t_{CAC}	Access Time from CAS		15		20		20	ns	6,7
19	t_{RL1QV}	t_{RAC}	Access Time from RAS		60		70		80	ns	6,8,9
20	t_{AVQV}	t_{CAA}	Access Time from Column Address		30		35		40	ns	6,7, 10

AC Characteristics (Cont'd.)

#	JEDEC Symbol	Symbol	Parameter	60/L		70/L		80/L		Unit	Notes
				Min.	Max.	Min.	Max.	Min.	Max.		
21	t_{CL1QX}	t_{LZ}	\overline{OE} or \overline{CAS} to Low-Z Output	0		0		0		ns	16
22	t_{CH2QZ}	t_{HZ}	\overline{OE} or \overline{CAS} to High-Z Output	0	20	0	20	0	20	ns	16
23	t_{RL1AX}	t_{AR}	Column Address Hold Time from \overline{RAS}	50		55		60		ns	
24	t_{RL1AV}	t_{RAD}	\overline{RAS} to Column Address Delay Time	15	30	15	35	15	40	ns	11
25	$t_{CL1RH1(W)}$	$t_{RSH(W)}$	\overline{RAS} or \overline{CAS} Hold Time in Write Cycle	15		20		20		ns	
26	t_{WL1CH1}	t_{CWL}	Write Command to \overline{CAS} Lead Time	15		20		20		ns	
27	t_{WL1CL2}	t_{WCS}	Write Command Setup Time	0		0		0		ns	12,13
28	t_{CL1WH1}	t_{WCH}	Write Command Hold Time	10		15		15		ns	
29	t_{WL1WH1}	t_{WP}	Write Pulse Width	10		15		15		ns	
30	t_{RL1WH1}	t_{WCR}	Write Command Hold Time from \overline{RAS}	50		55		60		ns	
31	t_{WL1RH1}	t_{RWL}	Write Command to \overline{RAS} Lead Time	15		20		20		ns	
32	t_{DVWL2}	t_{DS}	Data in Setup Time	0		0		0		ns	14
33	t_{WL1DX}	t_{DH}	Data in Hold Time	15		15		15		ns	14
34	t_{WL1GL2}	t_{WOH}	Write to \overline{OE} Hold Time	15		20		20		ns	14
35	t_{GH2DX}	t_{OED}	\overline{OE} to Data Delay Time	15		20		20		ns	14
36	$t_{RL2RL2(RMW)}$	t_{RWC}	Read-Modify-Write Cycle Time	170		185		205		ns	
37	$t_{RL1RH1(RMW)}$	t_{RRW}	Read-Modify-Write Cycle \overline{RAS} Pulse Width	105		125		135		ns	
38	t_{CL1WL2}	t_{CWD}	\overline{CAS} to \overline{WE} Delay	40		50		50		ns	12

2

AC Characteristics (Cont'd.)

#	JEDEC Symbol	Symbol	Parameter	60/L		70/L		80/L		Unit	Notes
				Min.	Max.	Min.	Max.	Min.	Max.		
39	t _{RL1WL2}	t _{RWD}	$\overline{\text{RAS}}$ to $\overline{\text{WE}}$ Delay in Read-Modify-Write Cycle	85		100		110		ns	12
40	t _{CL1CH1}	t _{CRW}	$\overline{\text{CAS}}$ Pulse Width (RMW)	65		75		75		ns	
41	t _{AVWL2}	t _{AWD}	Col. Address to $\overline{\text{WE}}$ Delay	60		65		70		ns	12
42	t _{CL2CL2}	t _{PC}	Fast Page Mode Read or Write Cycle Time	40		45		50		ns	
43	t _{CH2CL2}	t _{CP}	$\overline{\text{CAS}}$ Precharge Time	10		10		10		ns	
44	t _{AVRH1}	t _{CAR}	Column Address to $\overline{\text{RAS}}$ Setup Time	30		35		45		ns	
45	t _{CH2QV}	t _{CAP}	Access Time from Column Precharge		35		40		45	ns	7
46	t _{RL1DX}	t _{DHR}	Data in Hold Time Referenced to $\overline{\text{RAS}}$	50		55		60		ns	
47	t _{CL1RL2}	t _{CSR}	$\overline{\text{CAS}}$ Setup Time $\overline{\text{CAS}}$ -before- $\overline{\text{RAS}}$ Refresh	10		10		10		ns	
48	t _{RH2CL2}	t _{RPC}	$\overline{\text{RAS}}$ to $\overline{\text{CAS}}$ Precharge Time	10		10		10		ns	
49	t _{RL1CH1}	t _{CHR}	$\overline{\text{CAS}}$ Hold Time $\overline{\text{CAS}}$ -before- $\overline{\text{RAS}}$ Refresh	30		30		30		ns	
50	t _{CL2CL2 (RMW)}	t _{PCM}	Fast Page Mode Read-Modify-Write Cycle Time	85		95		100		ns	
	t _T	t _T	Transition Time (Rise and Fall)	3	50	3	50	3	50	ns	15
		t _{REF}	Refresh Interval (512 Cycles)		8		8		8	ms	17
		t _{REF}	Refresh Interval V53C104FL Only (512 Refresh cycles, t _{RC} =125 μs)		64		64		64	ms	17,18

1. I_{DD} is dependent on output loading when the device output is selected. Specified I_{DD} (max.) is measured with the output open.
2. I_{DD} is dependent upon the number of address transitions. Specified I_{DD} (max.) is measured with a maximum of two transitions per address cycle in Fast Page Mode.
3. Specified V_{IL} (min.) is steady state operating. During transitions, V_{IL} (min.) may undershoot to -1.0 V for a period not to exceed 20 ns. All AC parameters are measured with V_{IL} (min.) $\geq V_{SS}$ and V_{IH} (max.) $\leq V_{DD}$.
4. t_{RCD} (max.) is specified for reference only. Operation within t_{RCD} (max.) limits insures that t_{RAC} (max.) and t_{CAA} (max.) can be met. If t_{RCD} is greater than the specified t_{RCD} (max.), the access time is controlled by t_{CAA} and t_{CAC} .
5. Either t_{RRH} or t_{RCH} must be satisfied for a Read Cycle to occur.
6. Measured with a load equivalent to two TTL inputs and 100 pF.
7. Access time is determined by the longest of t_{CAA} , t_{CAC} and t_{CAP} .
8. Assumes that $t_{RAD} \leq t_{RAD}$ (max.). If t_{RAD} is greater than t_{RAD} (max.), t_{RAC} will increase by the amount that t_{RAD} exceeds t_{RAD} (max.).
9. Assumes that $t_{RCD} \leq t_{RCD}$ (max.). If t_{RCD} is greater than t_{RCD} (max.), t_{RAC} will increase by the amount that t_{RCD} exceeds t_{RCD} (max.).
10. Assumes that $t_{RAD} \geq t_{RAD}$ (max.).
11. Operation within the t_{RAD} (max.) limit ensures that t_{RAC} (max.) can be met. t_{RAD} (max.) is specified as a reference point only. If t_{RAD} is greater than the specified t_{RAD} (max.) limit, the access time is controlled by t_{CAA} and t_{CAC} .
12. t_{WCS} , t_{RWD} , t_{AWD} and t_{CWD} are not restrictive operating parameters.
13. t_{WCS} (min.) must be satisfied in an Early Write Cycle.
14. t_{DS} and t_{DH} are referenced to the latter occurrence of \overline{CAS} or \overline{WE} .
15. t_T is measured between V_{IH} (min.) and V_{IL} (max.). AC-measurements assume $t_T = 5$ ns.
16. Assumes a three-state test load (5 pF and a 380 Ohm Thevenin equivalent).
17. An initial 200 μ s pause and 8 \overline{RAS} -containing cycles are required when exiting an extended period of bias without clocks. An extended period of time without clocks is defined as one that exceeds the specified Refresh Interval.
18. This is battery backup data retention mode under \overline{CAS} before \overline{RAS} refresh cycles.

$$t_{RC} = 125 \mu s (125 \mu s \times 512 = 64 \text{ ms})$$

$$t_{RAS} = t_{RAS} \text{ (min.) to } 1 \mu s$$

$$\text{Input voltages : } \overline{RAS} \text{ and } \overline{CAS} \quad V_{IH} > V_{DD} - 0.2 \text{ V}$$

$$V_{IL} < 0.2 \text{ V}$$

$$\overline{WE} \text{ and } \overline{OE} \quad V_{IN} > V_{DD} - 0.2 \text{ V}$$

All other inputs at stable V_{IH} or V_{IL}

Waveforms of Read Cycle

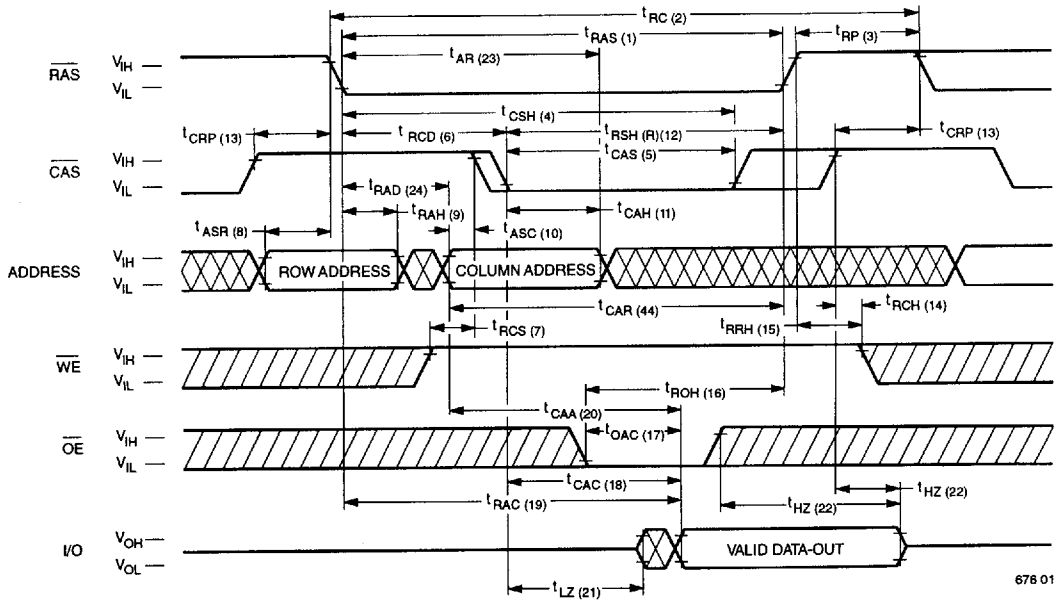

Waveforms of Early Write Cycle

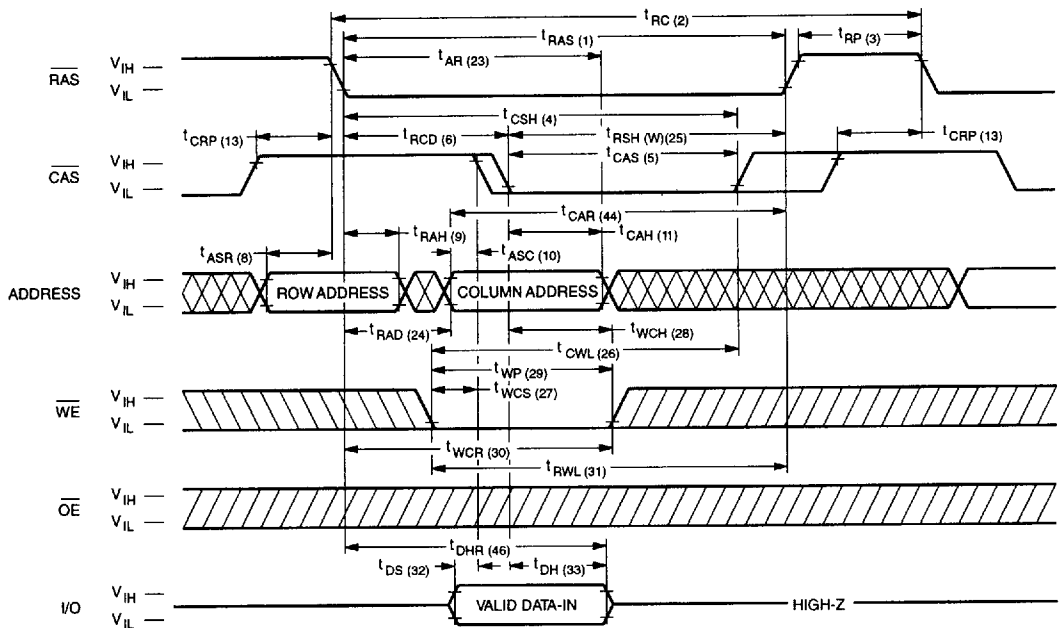

Waveforms of \overline{OE} Controlled Write Cycle

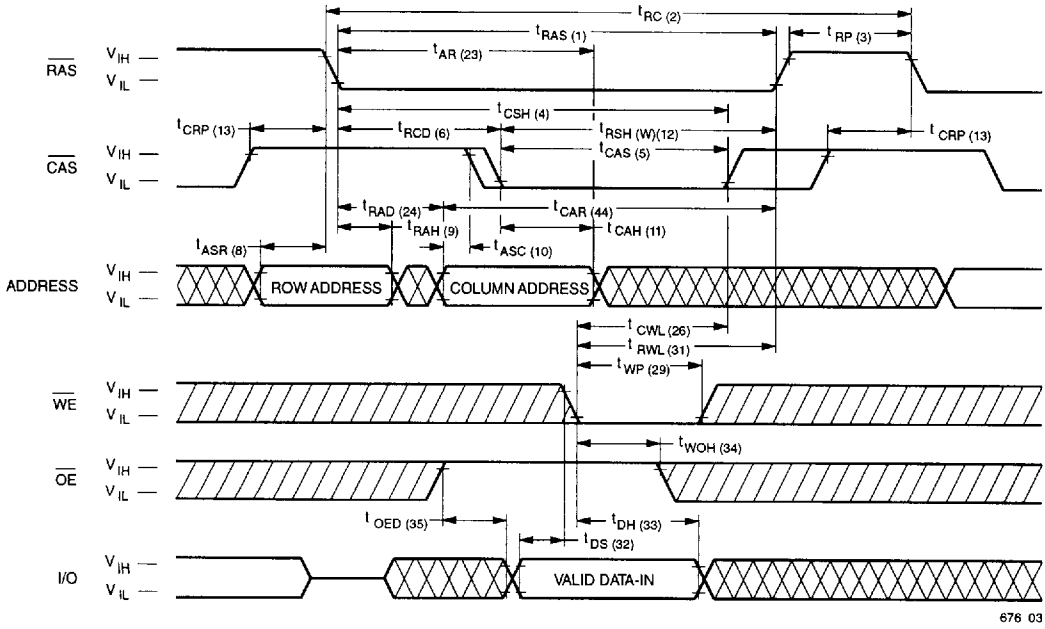

2

Waveforms of Read-Modify-Write Cycle

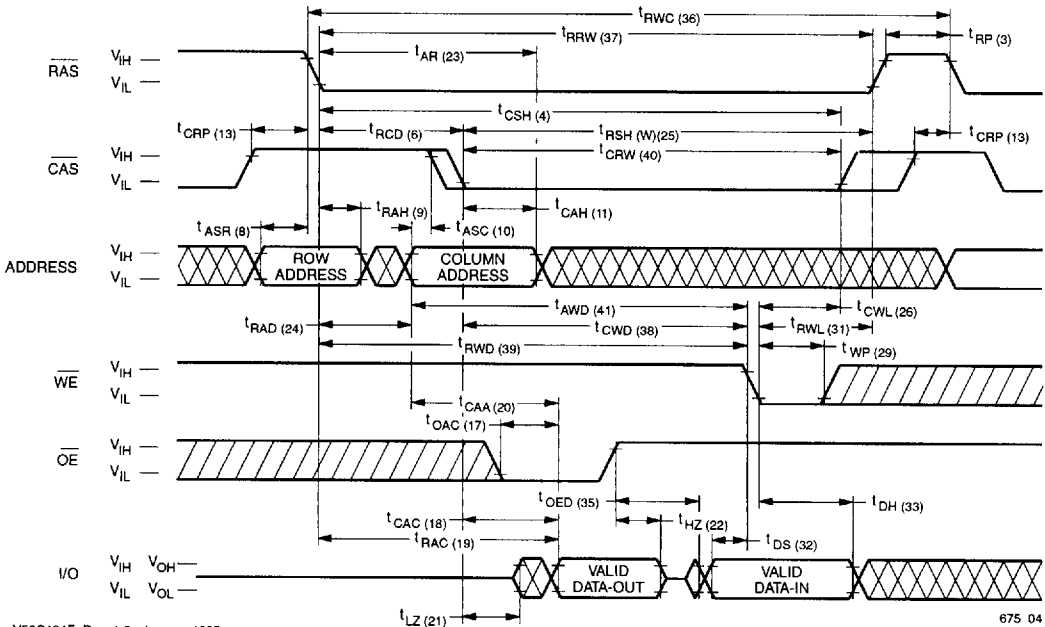

Waveforms of Fast Page Mode Read Cycle

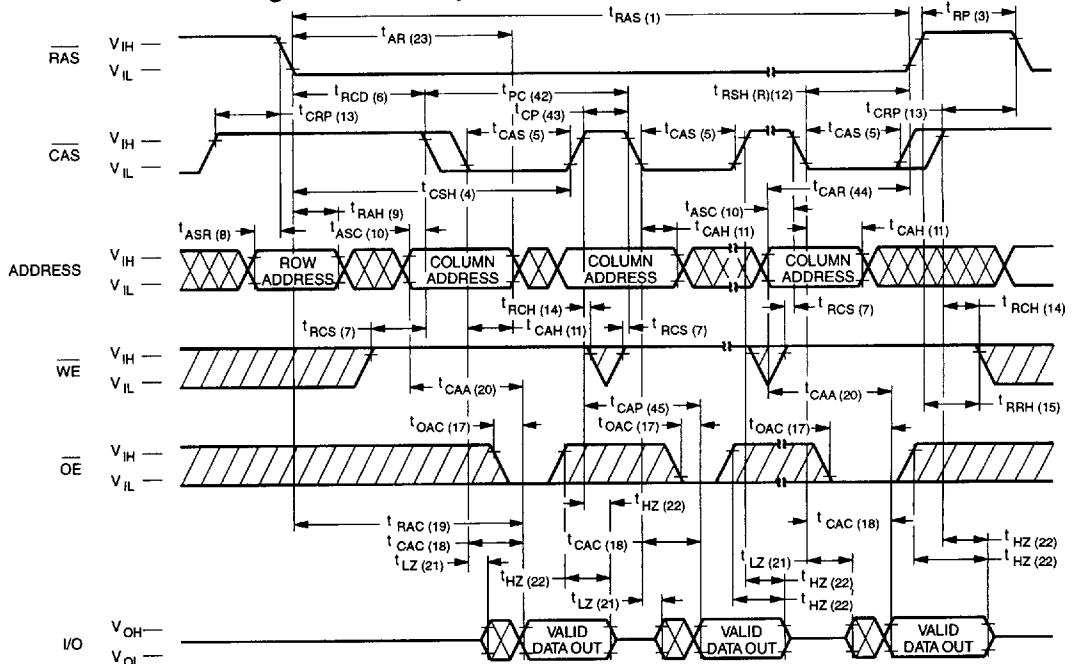

676 05

Waveforms of Fast Page Mode Write Cycle

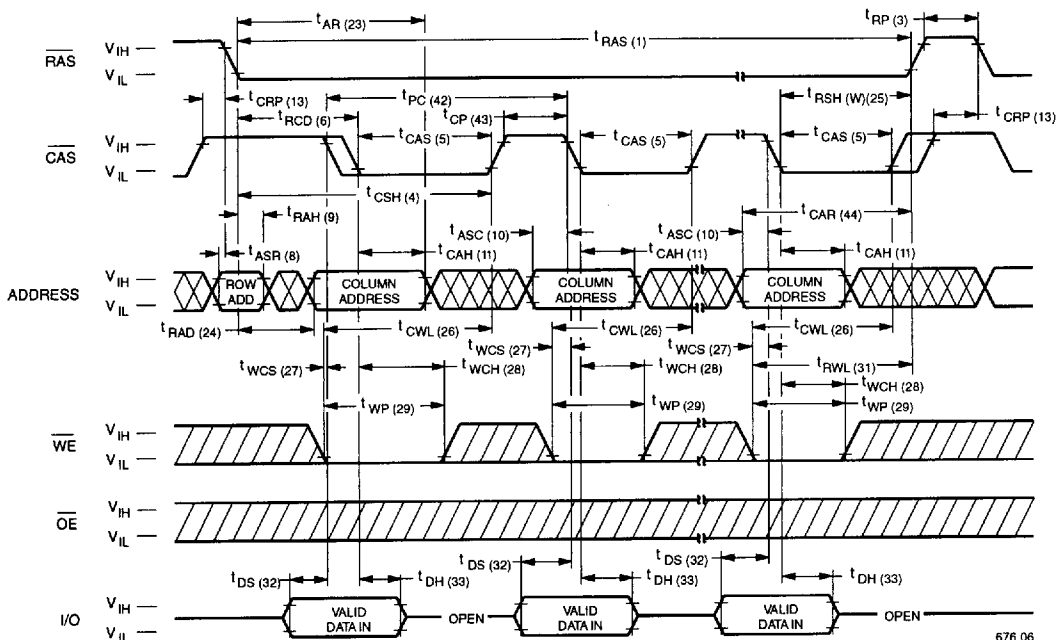

676 06

Waveforms of Fast Page Mode Read-Write Cycle

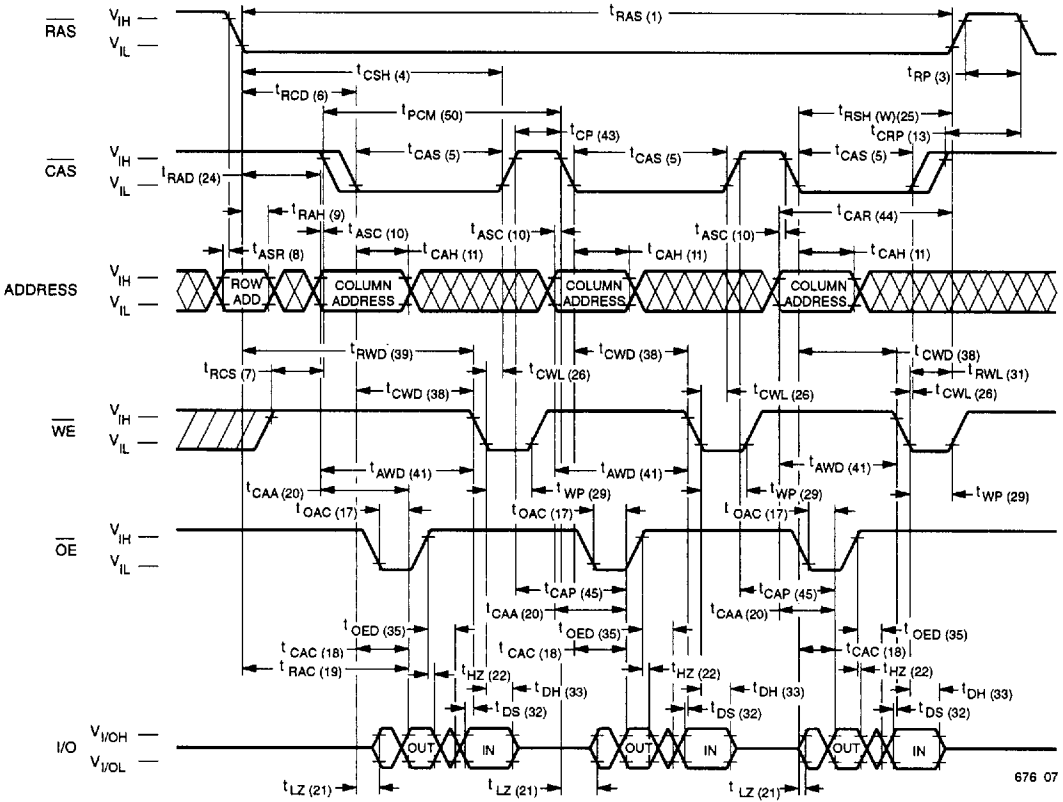

2

Waveforms of RAS-Only Refresh Cycle

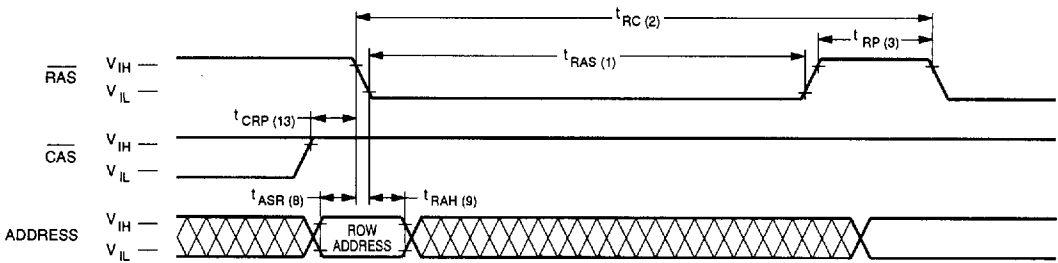

NOTE: WE, OE = Don't care

Waveforms of CAS-before-RAS Refresh Cycle

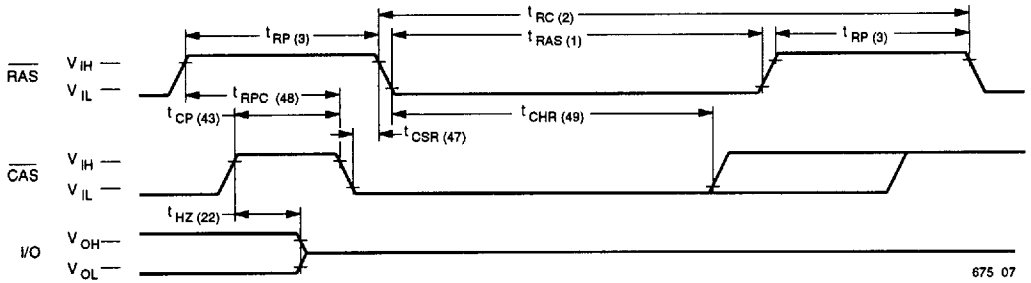

675 07

NOTE: \overline{WE} , \overline{OE} , A_0-A_7 = Don't care

Waveforms of Hidden Refresh Cycle (Read)

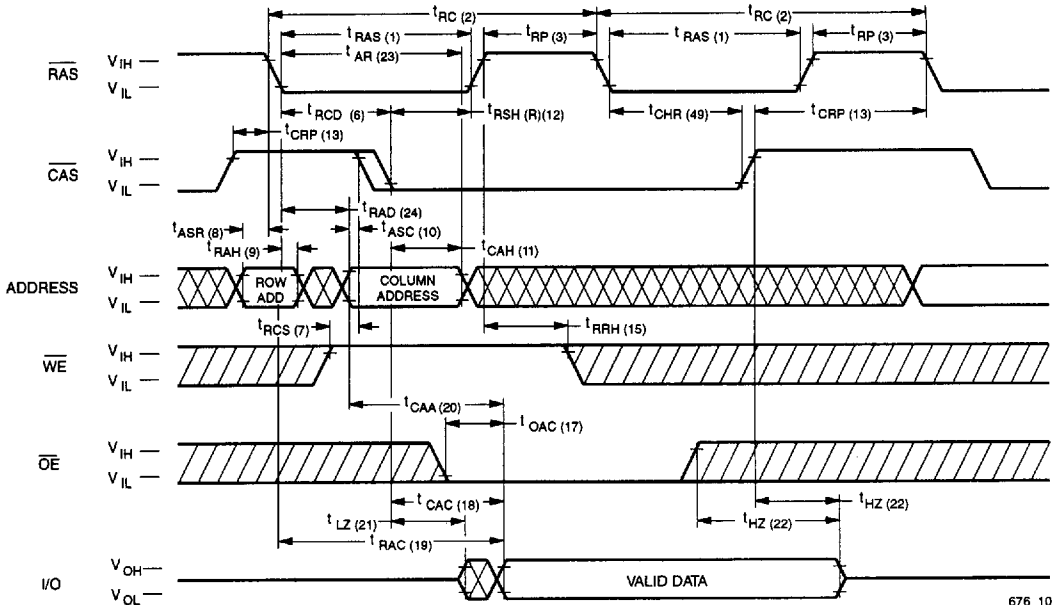

676 10

Waveforms of Hidden Refresh Cycle (Write)

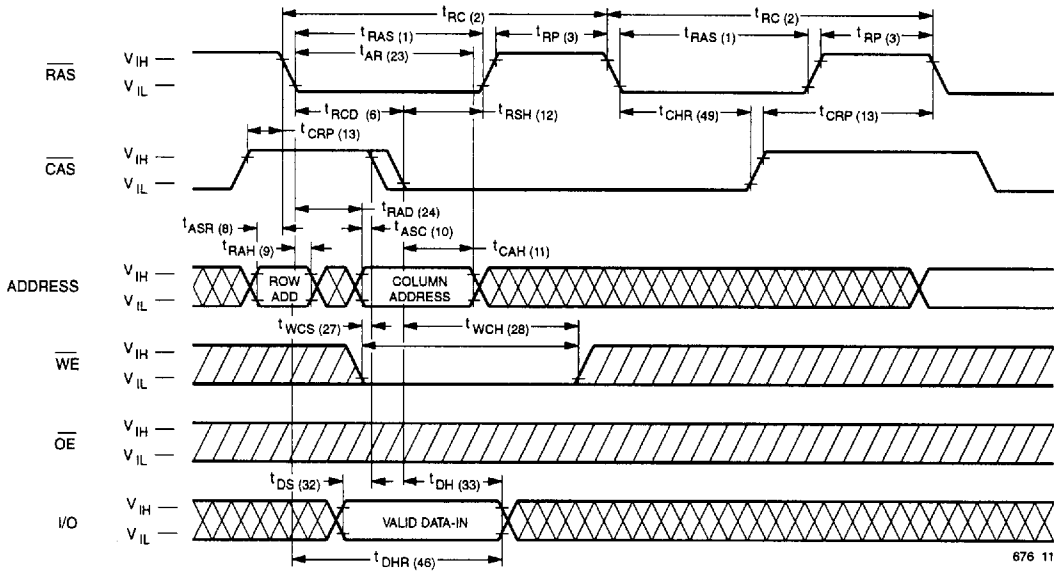

2

Waveforms of $\overline{\text{CAS}}$ -before- $\overline{\text{RAS}}$ Refresh Counter Test Cycle

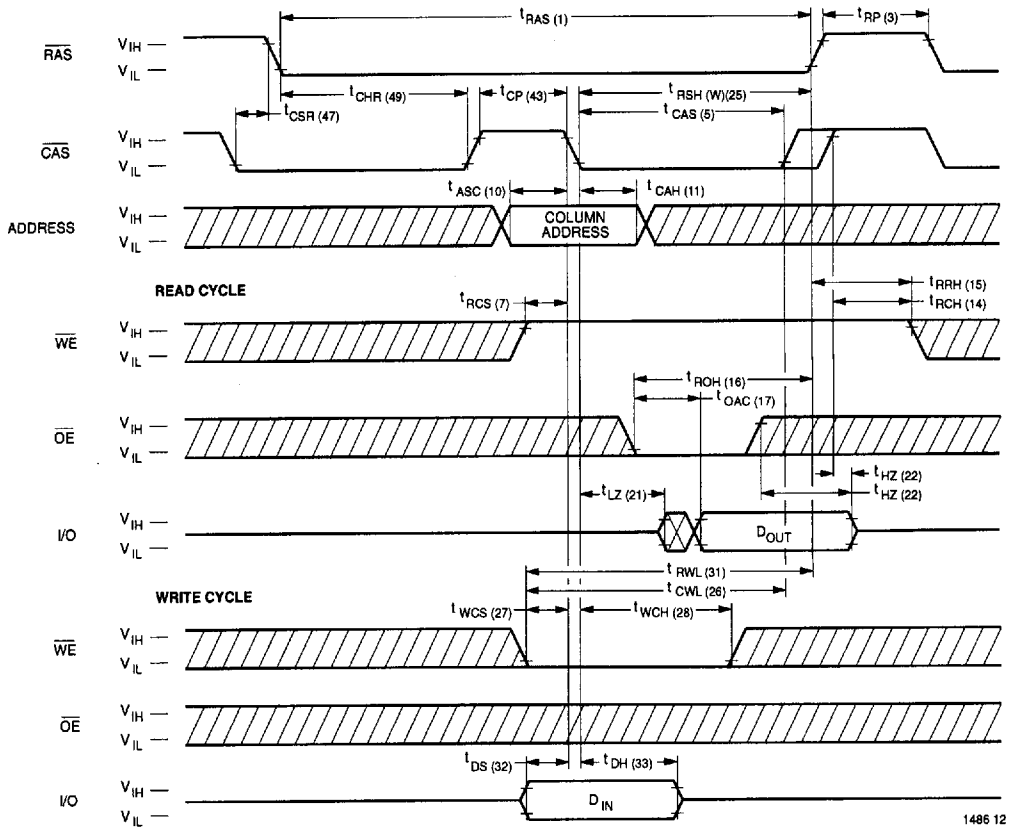

1486 12

Functional Description

The V53C104F is a CMOS dynamic RAM optimized for high data bandwidth, low power applications. It is functionally similar to a traditional dynamic RAM. The V53C104F reads and writes data by multiplexing an 18-bit address into a 9-bit row and a 9-bit column address. The row address is latched by the Row Address Strobe ($\overline{\text{RAS}}$). The column address "flows through" an internal address buffer and is latched by the Column Address Strobe ($\overline{\text{CAS}}$). Because access time is primarily dependent on a valid column address rather than the precise time that the $\overline{\text{CAS}}$ edge occurs, the delay time from $\overline{\text{RAS}}$ to $\overline{\text{CAS}}$ has little effect on the access time.

Memory Cycle

A memory cycle is initiated by bringing $\overline{\text{RAS}}$ low. Any memory cycle, once initiated, must not be ended or aborted before the minimum t_{RAS} time has expired. This ensures proper device operation and data integrity. A new cycle must not be initiated until the minimum precharge time $t_{\text{RP}}/t_{\text{CP}}$ has elapsed.

Read Cycle

A Read cycle is performed by holding the Write Enable ($\overline{\text{WE}}$) signal High during a $\overline{\text{RAS}}/\overline{\text{CAS}}$ operation. The column address must be held for a minimum specified by t_{AR} . Data Out becomes valid only when t_{OAC} , t_{RAC} , t_{CAA} and t_{CAC} are all satisfied. As a result, the access time is dependent on the timing relationships between these parameters. For example, the access time is limited by t_{CAA} when t_{RAC} , t_{CAC} and t_{OAC} are all satisfied.

Write Cycle

A Write Cycle is performed by taking $\overline{\text{WE}}$ and $\overline{\text{CAS}}$ low during a $\overline{\text{RAS}}$ operation. The column address is latched by $\overline{\text{CAS}}$. The Write Cycle can be $\overline{\text{WE}}$ controlled or $\overline{\text{CAS}}$ controlled depending on whether $\overline{\text{WE}}$ or $\overline{\text{CAS}}$ falls later. Consequently, the input data must be valid at or before the falling edge of $\overline{\text{WE}}$ or $\overline{\text{CAS}}$, whichever occurs last. In the $\overline{\text{CAS}}$ -controlled Write Cycle, when the leading edge of $\overline{\text{WE}}$ occurs prior to the $\overline{\text{CAS}}$ low transition, the I/O data pins will be in the High-Z state at the beginning of the Write function.

Ending the Write with $\overline{\text{RAS}}$ or $\overline{\text{CAS}}$ will maintain the output in the High-Z state.

In the $\overline{\text{WE}}$ controlled Write Cycle, $\overline{\text{OE}}$ must be in the high state and t_{OED} must be satisfied.

Refresh Cycle

To retain data, 512 Refresh Cycles are required in each 8 ms period. There are two ways to refresh the memory:

1. By clocking each of the 512 row addresses (A_0 through A_9) with $\overline{\text{RAS}}$ at least once every 8 ms. Any Read, Write, Read-Modify-Write or $\overline{\text{RAS}}$ -only cycle refreshes the addressed row.
2. Using a $\overline{\text{CAS}}$ -before- $\overline{\text{RAS}}$ Refresh Cycle. If $\overline{\text{CAS}}$ makes a transition from low to high to low after the previous cycle and before $\overline{\text{RAS}}$ falls, $\overline{\text{CAS}}$ -before- $\overline{\text{RAS}}$ refresh is activated. The V53C104F uses the output of an internal 9-bit counter as the source of row addresses and ignore external address inputs.

$\overline{\text{CAS}}$ -before- $\overline{\text{RAS}}$ is a "refresh-only" mode and no data access or device selection is allowed. Thus, the output remains in the High-Z state during the cycle. A $\overline{\text{CAS}}$ -before- $\overline{\text{RAS}}$ counter test mode is provided to ensure reliable operation of the internal refresh counter.

Data Retention Mode

The V53C104F offers a CMOS standby mode that is entered by causing the $\overline{\text{RAS}}$ clock to swing between a valid V_{IL} and an "extra high" V_{IH} within 0.2 V of V_{DD} . While the $\overline{\text{RAS}}$ clock is at the "extra high" level, the V53C104F power consumption is reduced to the low I_{DD6} level. Overall I_{DD} consumption when operating in this mode can be calculated as follows:

$$I = \frac{(t_{\text{RC}}) \times (I_{\text{DD1}}) + (t_{\text{RX}} - t_{\text{RC}}) \times (I_{\text{DD6}})}{t_{\text{RX}}}$$

Where: t_{RC} = Refresh Cycle Time
 t_{RX} = Refresh Interval / 512

Fast Page Mode Operation

Fast Page Mode operation permits all 512 columns within a selected row of the device to be randomly accessed at a high data rate. Maintaining $\overline{\text{RAS}}$ low while performing successive $\overline{\text{CAS}}$ cycles retains the row address internally and eliminates the need to reapply it for each cycle. The column address buffer acts as a transparent or flow-through latch while $\overline{\text{CAS}}$ is high. Thus, access begins from the occurrence of a valid column address rather than from the falling edge of $\overline{\text{CAS}}$, eliminating t_{ASC} and t_{T} from the critical timing path. $\overline{\text{CAS}}$ latches the address into the column address buffer and acts as an output enable. During Fast Page Mode operation, Read, Write, Read-Modify-Write or Read-Write-Read cycles are possible at random addresses within a row. Following the initial entry cycle into Fast Page Mode, access is t_{CAA} or t_{CAP} controlled. If the column address is valid prior to the rising edge of $\overline{\text{CAS}}$, the access time is referenced to the $\overline{\text{CAS}}$ rising edge and is specified by t_{CAP} . If the column address is valid after the rising $\overline{\text{CAS}}$ edge, access is timed from the occurrence of a valid address and is specified by t_{CAA} . In both cases, the falling edge of $\overline{\text{CAS}}$ latches the address and enables the output.

Fast Page Mode provides a sustained data rate of 25 MHz for applications that require high data rates such as bit-mapped graphics or high-speed signal processing. The following equation can be used to calculate the maximum data rate:

$$\text{Data Rate} = \frac{512}{t_{\text{RC}} + 511 \times t_{\text{PC}}}$$

Data Output Operation

The V53C104F Input/Output is controlled by $\overline{\text{OE}}$, $\overline{\text{CAS}}$, $\overline{\text{WE}}$ and $\overline{\text{RAS}}$. A $\overline{\text{RAS}}$ low transition enables the transfer of data to and from the selected row address in the Memory Array. A $\overline{\text{RAS}}$ high transition disables data transfer and latches the output data if the output is enabled. After a memory cycle is initiated with a $\overline{\text{RAS}}$ low transition, a $\overline{\text{CAS}}$ low transition or $\overline{\text{CAS}}$ low level enables the internal I/O path. A $\overline{\text{CAS}}$ high transition or a $\overline{\text{CAS}}$ high level disables the I/O path and the output driver if it is enabled. A $\overline{\text{CAS}}$ low transition while $\overline{\text{RAS}}$ is high has no effect on the I/O data path or on the output drivers. The output drivers, when otherwise enabled, can be disabled by holding

$\overline{\text{OE}}$ high. The $\overline{\text{OE}}$ signal has no effect on any data stored in the output latches. A $\overline{\text{WE}}$ low level can also disable the output drivers when $\overline{\text{CAS}}$ is low. During a Write cycle, if $\overline{\text{WE}}$ goes low at a time in relationship to $\overline{\text{CAS}}$ that would normally cause the outputs to be active, it is necessary to use $\overline{\text{OE}}$ to disable the output drivers prior to the $\overline{\text{WE}}$ low transition to allow Data In Setup Time (t_{DS}) to be satisfied.

Power-On

After application of the V_{DD} supply, an initial pause of 200 μs is required followed by a minimum of 8 initialization cycles (any combination of cycles containing a $\overline{\text{RAS}}$ clock). Eight initialization cycles are required after extended periods of bias without clocks (greater than the Refresh Interval).

During Power-On, the V_{DD} current requirement of the V53C104F is dependent on the input levels of $\overline{\text{RAS}}$ and $\overline{\text{CAS}}$. If $\overline{\text{RAS}}$ is low during Power-On, the device will go into an active cycle and I_{DD} will exhibit current transients. It is recommended that $\overline{\text{RAS}}$ and $\overline{\text{CAS}}$ track with V_{DD} or be held at a valid V_{IH} during Power-On to avoid current surges.

Table 1. V53C104F Data Output Operation for Various Cycle Types

Cycle Type	I/O State
Read Cycles	Data from Addressed Memory Cell
$\overline{\text{CAS}}$ -Controlled Write Cycle (Early Write)	High-Z
$\overline{\text{WE}}$ -Controlled Write Cycle (Late Write)	$\overline{\text{OE}}$ Controlled. High $\overline{\text{OE}} = \text{High-Z I/Os}$
Read-Modify-Write Cycles	Data from Addressed Memory Cell
Fast Page Mode Read	Data from Addressed Memory Cell
Fast Page Mode Write Cycle (Early Write)	High-Z
Fast Page Mode Read-Modify-Write Cycle	Data from Addressed Memory Cell
$\overline{\text{RAS}}$ -only Refresh	High-Z
$\overline{\text{CAS}}$ -before- $\overline{\text{RAS}}$ Refresh Cycle	Data remains as in previous cycle
$\overline{\text{CAS}}$ -only Cycles	High-Z

This datasheet has been download from :

www.AllDataSheet.com

100% Free DataSheet Search Site.

Free Download.

No Register.

Fast Search System.

www.AllDataSheet.com