

# Module with HiPerFET™ H-Bridge and Single Phase Mains Rectifier Bridge

Preliminary

$V_{DSS} = 500\text{ V}$   
 $R_{DSon} = 116\text{ m}\Omega$   
 $V_{RRM} = 1200\text{ V}$   
 $I_{DAV25} = 90\text{ A}$

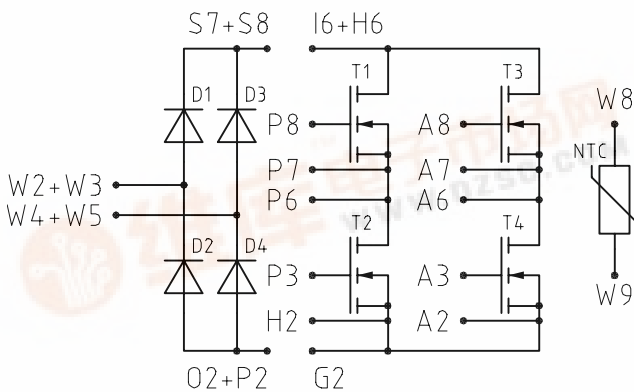

Mains Rectifier Bridge D1 - D4

Symbol	Conditions	Maximum Ratings	
$V_{RRM}$		1200	V
$I_{FAV25}$	$T_C = 25^\circ\text{C}$ ; sine 180°	45	A
$I_{FAV80}$	$T_C = 80^\circ\text{C}$ ; sine 180°	33	A
$I_{FSM}$	$T_{VJ} = 25^\circ\text{C}$ ; $t = 10\text{ ms}$ sine 50 Hz	400	A

Symbol	Conditions	Characteristic Values ( $T_{VJ} = 25^\circ\text{C}$ , unless otherwise specified)		
		min.	typ.	max.
$V_F$	$I_F = 20\text{ A}$	$T_{VJ} = 25^\circ\text{C}$ $T_{VJ} = 125^\circ\text{C}$	1.1 1.0	1.2 V
$I_R$	$V_R = V_{RRM}$	$T_{VJ} = 25^\circ\text{C}$ $T_{VJ} = 125^\circ\text{C}$	0.4	0.02 mA mA
$R_{thJC}$ $R_{thJS}$	(per diode) with heat transfer paste		2.8	1.42 K/W K/W

## Application

- primary side of mains supplied
- welding converters
- switched mode power supplies
- induction heaters

## Features

- H-bridge with HiPerFET™ technology:
  - low  $R_{DSon}$
  - unclamped inductive switching (UIS) capability
  - dv/dt ruggedness
  - fast intrinsic reverse diode
  - Kelvin source for easy drive
  - low inductive, symmetrical current paths
- thermistor for internal temperature measurement
- package:
  - high level of integration - only one power semiconductor module required for the whole primary side
  - solder terminals for PCB mounting
  - isolated DCB ceramic base plate

**MOSFET H - Bridge T1 - T4**

Symbol	Conditions	Maximum Ratings	
$V_{DSS}$	$T_{VJ} = 25^{\circ}\text{C}$ to $150^{\circ}\text{C}$	500	V
$V_{GS}$		$\pm 20$	V
$I_{D25}$	$T_C = 25^{\circ}\text{C}$	40	A
$I_{D80}$	$T_C = 80^{\circ}\text{C}$	30	A
$I_{F25}$	(diode) $T_C = 25^{\circ}\text{C}$	40	A
$I_{F80}$	(diode) $T_C = 80^{\circ}\text{C}$	30	A

Symbol	Conditions	Characteristic Values ( $T_{VJ} = 25^{\circ}\text{C}$ , unless otherwise specified)			
		min.	typ.	max.	
$R_{DSon}$	$V_{GS} = 10\text{ V}; I_D = I_{D80}$			116 m $\Omega$	
$V_{GSth}$	$V_{DS} = 20\text{ V}; I_D = 8\text{ mA}$	2		4 V	
$I_{DSS}$	$V_{DS} = 0.8 \cdot V_{DSS}; V_{GS} = 0\text{ V}; T_{VJ} = 25^{\circ}\text{C}$ $T_{VJ} = 125^{\circ}\text{C}$		0.5	0.4 mA mA	
$I_{GSS}$	$V_{GS} = \pm 20\text{ V}; V_{DS} = 0\text{ V}$			0.2 $\mu\text{A}$	
$Q_g$ $Q_{gs}$ $Q_{gd}$	} $V_{GS} = 10\text{ V}; V_{DS} = 0.5 \cdot V_{DSS}; I_D = 20\text{ A}$		270 56 124	nC nC nC	
$t_{d(on)}$ $t_r$ $t_{d(off)}$ $t_f$		} $V_{GS} = 10\text{ V}; V_{DS} = 0.5 \cdot V_{DSS};$ $I_D = 20\text{ A}; R_G = 1\ \Omega$		50 100 100 80	ns ns ns ns
$V_F$			(diode) $I_F = 20\text{ A}; V_{GS} = 0\text{ V}$		1.5
$t_{rr}$	(diode) $I_F = 40\text{ A}; -di/dt = 200\text{ A}/\mu\text{s}; V_{DS} = 100\text{ V}$		300		ns
$R_{thJC}$ $R_{thJS}$	with heat transfer paste		0.47		0.32 K/W K/W

**Temperature Sensor NTC**

Symbol	Conditions	Characteristic Values		
		min.	typ.	max.
$R_{25}$ $B_{25/100}$	$T = 25^{\circ}\text{C}$	1950	2057 3560	$\Omega$ K

### Module

Symbol	Conditions	Maximum Ratings	
$T_{VJ}$		-40...+150	°C
$T_{stg}$		-40...+125	°C
$V_{ISOL}$	$I_{ISOL} \leq 1 \text{ mA}; 50/60 \text{ Hz}; t = 1 \text{ min}$	3000	V~
$M_d$	Mounting torque (M5)	2 - 2.5	Nm

Symbol	Conditions	Characteristic Values		
		$(T_{VJ} = 25^\circ\text{C}, \text{ unless otherwise specified})$		
		min.	typ.	max.
$d_s$	Creepage distance on surface	8		mm
$d_A$	Strike distance through air	8		mm
Weight	typ.		80	g

Dimensions in mm (1 mm = 0.0394")

