

ENCODER / DECODER 高工作電壓編碼 / 解碼器

VD5012/VD5013/VD5014

1.0 FEATURES

- Wide operating voltage (2 - 12V)
- Low standby current 1  $\mu$  A typical
- On-chip RC oscillator
- Four time transmission for error checking
- 4,096 combinations encoding capability
- Minimum external components
- Easy interface with RF, Ultrasonic or Infrared transmission media

特點

- 工作電壓 (2 - 12V)
- 靜態電流低, 典型 1  $\mu$  A
- 芯片上置有振盪器
- 4 次錯誤檢驗發送
- 最多可有 4,096 種編碼能力
- 外接零件少
- 容易與 RF, 超音波或紅外線  
傳送媒體連接

2.0 ELECTRICAL CHARACTERISTICS 電特性

$V_{DD} = 5V, T_A = 25^\circ C$  (unless otherwise specified 特別註明除外)

PARAMETER	SYMBOL	LIMITS			UNIT
		MIN	TYP	MAX	
Operating Voltage 工作電壓	$V_{DD}$	2	5	12	V
Standby Current 靜態電流	$I_{SBY}$	-	1	10	$\mu A$
Operating Current 工作電流	$I_{OP}$	-	1	-	mA
Source Current 來源電流 ( $V_{OH} = 4.5V$ )	$I_{OH}$	-1	-	-	mA
Sink Current 灌進電流 ( $V_{OL} = 0.5V$ )	$I_{OL}$	1	-	-	mA
Input Current 輸入電流	$I_{IN}(\overline{TE})$	-	-	25	$\mu A$

3.0 APPLICATION 應用

- Security systems 保安系統
- Theft alarm systems 防盜警告系統
- Cordless telephone 無線電話
- Smoke and fire alarm systems 煙火警告系統
- Garage door controller 車房門控制器
- Other remote control systems 其他遙控系統



4.0 APPLICATION INFORMATION 應用資料

$F_{osc}(VD5013) = 50F_{osc}(VD5012)$

TYP.  $R_{osc}(VD5012) = 3M\Omega$

TYP.  $R_{osc}(VD5013) = 230K\Omega$

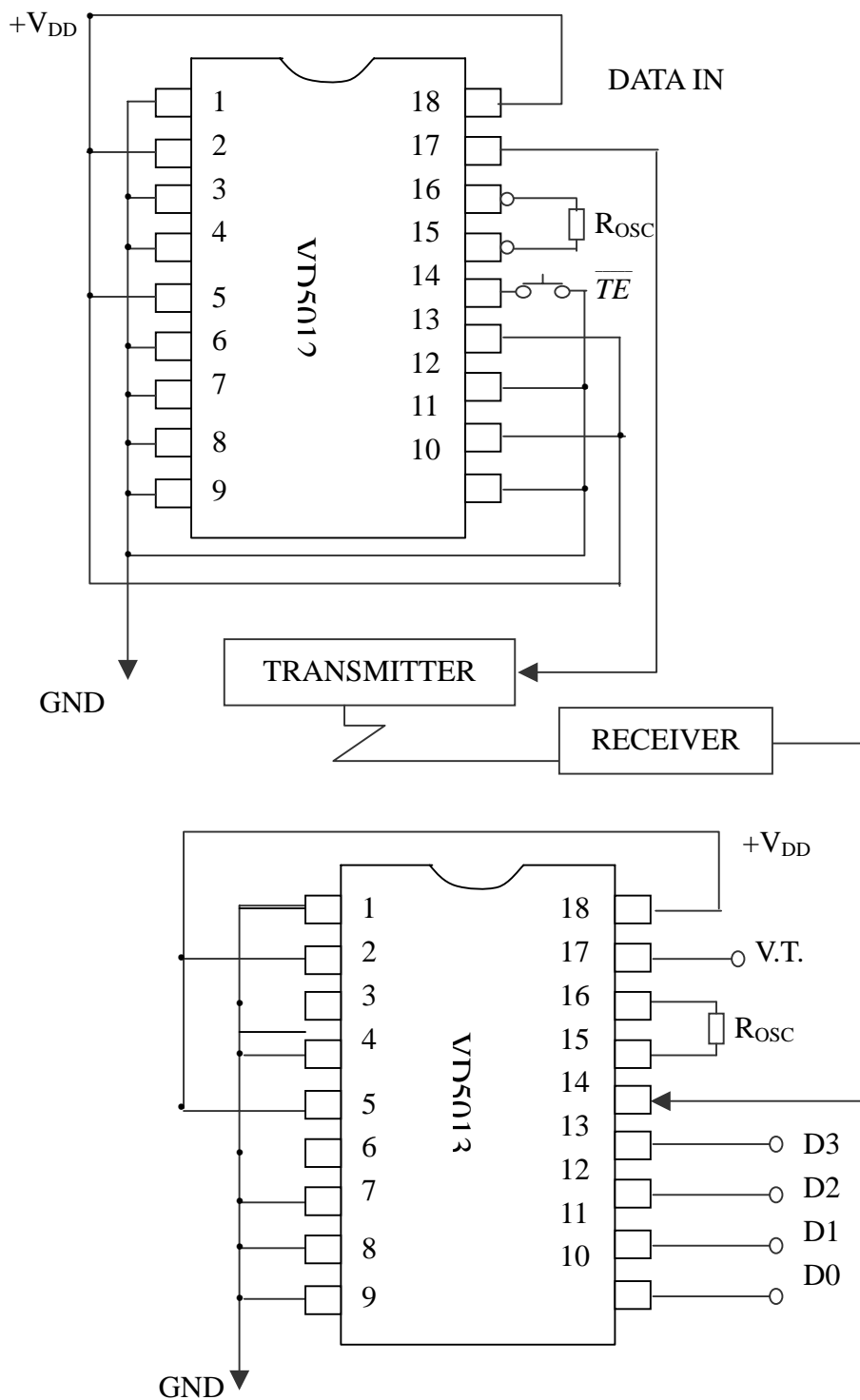

$F_{osc}(VD5014) = 50F_{osc}(VD5012)$

TYP.  $R_{osc}(VD5012) = 3M\Omega$

TYP.  $R_{osc}(VD5014) = 230K\Omega$

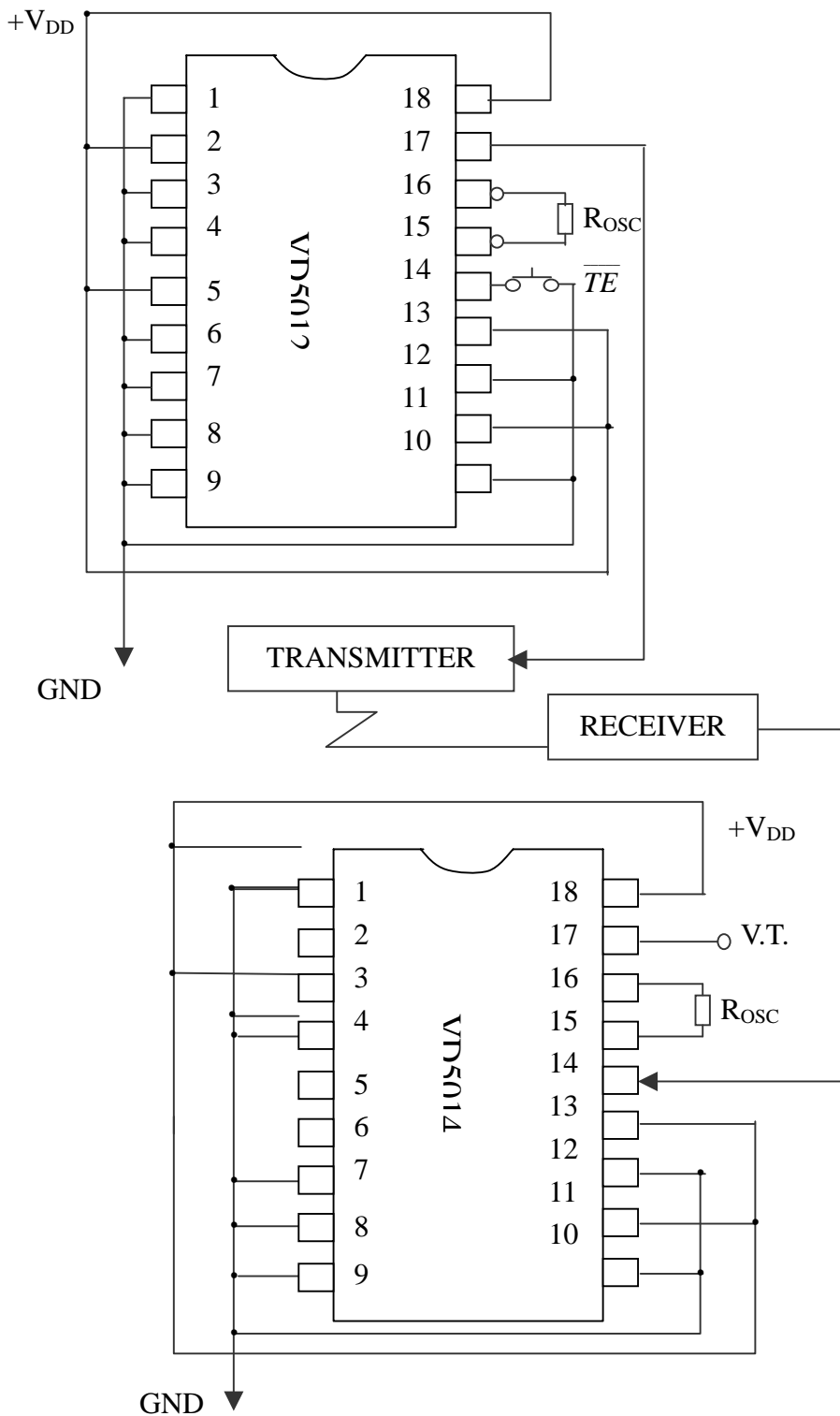

The IC substrate should be connected to V<sub>DD</sub>. 芯片襯底請接V<sub>DD</sub>.