

MOTOROLA
SEMICONDUCTOR TECHNICAL DATA

2-Input Differential AND/NAND

The MC100LVEL05 is a 2-input differential AND/NAND gate. The device is functionally equivalent to the MC100EL05 device and operates from a 3.3V supply voltage. With propagation delays and output transition times equivalent to the EL05, the LVEL05 is ideally suited for those applications which require the ultimate in AC performance at low voltage power supplies.

Because a negative 2-input NAND is equivalent to a 2-input OR function, the differential inputs and outputs of the device allows the LVEL05 to also be used as a 2-input differential OR/NOR gate.

- 340ps Propagation Delay
- High Bandwidth Output Transitions
- 75kΩ Internal Input Pulldown Resistors
- >2000V ESD Protection

LOGIC DIAGRAM AND PINOUT ASSIGNMENT

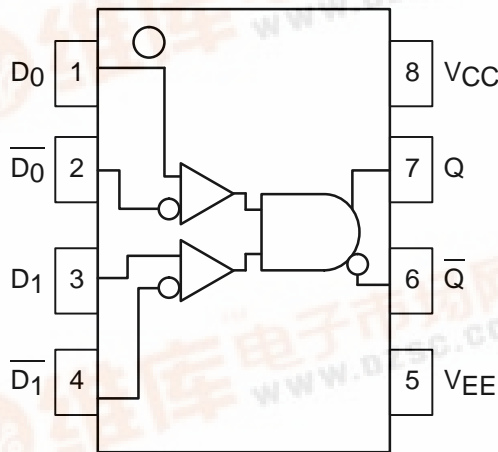

MC100LVEL05



D SUFFIX
8-LEAD PLASTIC SOIC PACKAGE
CASE 751-05

PIN DESCRIPTION

PIN	FUNCTION
D0, D1 Q	Data Inputs Data Outputs



MC100LVEL05

DC CHARACTERISTICS ($V_{EE} = V_{EE}(\text{min})$ to $V_{EE}(\text{max})$; $V_{CC} = \text{GND}$)

Symbol	Characteristic	-40°C			0°C			25°C			85°C			Unit
		Min	Typ	Max	Min	Typ	Max	Min	Typ	Max	Min	Typ	Max	
I_{EE}	Power Supply Current		18	25		18	25		18	25		19	26	mA
V_{EE}	Power Supply Voltage	-3.0		-3.8	-3.0		-3.8	-3.0		-3.8	-3.0		-3.8	V
I_{IH}	Input HIGH Current			150			150			150			150	μA
I_{IL}	Input LOW Current	0.5			0.5			0.5			0.5			μA

AC CHARACTERISTICS ($V_{EE} = V_{EE}(\text{min})$ to $V_{EE}(\text{max})$; $V_{CC} = \text{GND}$)

Symbol	Characteristic	-40°C			0°C			25°C			85°C			Unit
		Min	Typ	Max	Min	Typ	Max	Min	Typ	Max	Min	Typ	Max	
t_{PLH} t_{PHL}	Propagation Delay to Output	240	260	440	240		440	240	340	440	250		450	ps
V_{PP}	Minimum Input Swing (Note 1.)	150			150			150			150			mV
V_{CMR}	Common Mode Range (Note 2.) $V_{PP} < 500\text{mV}$ $V_{PP} \geq 500\text{mV}$	-2.1 -1.9		-0.2 -0.2	-2.2 -2.0		-0.2 -0.2	-2.2 -2.0		-0.2 -0.2	-2.2 -2.0		-0.2 -0.2	V
t_r t_f	Output Rise/Fall Times Q (20% – 80%)	100		320	100		320	100	210	320	100		320	ps

1. Minimum input swing for which AC parameters are guaranteed. The device has a DC gain of ≈ 40 .
2. The CMR range is referenced to the most positive side of the differential input signal. Normal operation is obtained if the HIGH level falls within the specified range and the peak-to-peak voltage lies between V_{PPmin} and 1V. The lower end of the CMR range varies 1:1 with V_{EE} . The number in the spec table assumes a nominal $V_{EE} = -3.3\text{V}$. Note for PECL operation, the $V_{CMR}(\text{min})$ will be fixed at $3.3\text{V} - |V_{CMR}(\text{min})|$.

OUTLINE DIMENSIONS

D SUFFIX
PLASTIC SOIC PACKAGE
CASE 751-05
ISSUE R

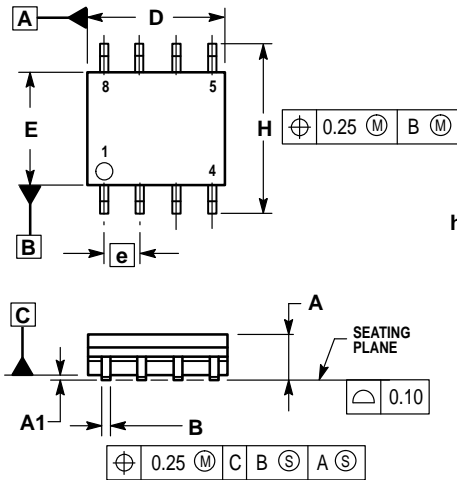

- NOTES:
1. DIMENSIONING AND TOLERANCING PER ASME Y14.5M, 1994.
 2. DIMENSIONS ARE IN MILLIMETERS.
 3. DIMENSION D AND E DO NOT INCLUDE MOLD PROTRUSION.
 4. MAXIMUM MOLD PROTRUSION 0.15 PER SIDE.
 5. DIMENSION B DOES NOT INCLUDE MOLD PROTRUSION. ALLOWABLE DAMBAR PROTRUSION SHALL BE 0.127 TOTAL IN EXCESS OF THE B DIMENSION AT MAXIMUM MATERIAL CONDITION.

DIM	MILLIMETERS	
	MIN	MAX
A	1.35	1.75
A1	0.10	0.25
B	0.35	0.49
C	0.18	0.25
D	4.80	5.00
E	3.80	4.00
e	1.27 BSC	
H	5.80	6.20
h	0.25	0.50
L	0.40	1.25
θ	0°	7°

Motorola reserves the right to make changes without further notice to any products herein. Motorola makes no warranty, representation or guarantee regarding the suitability of its products for any particular purpose, nor does Motorola assume any liability arising out of the application or use of any product or circuit, and specifically disclaims any and all liability, including without limitation consequential or incidental damages. "Typical" parameters which may be provided in Motorola data sheets and/or specifications can and do vary in different applications and actual performance may vary over time. All operating parameters, including "Typicals" must be validated for each customer application by customer's technical experts. Motorola does not convey any license under its patent rights nor the rights of others. Motorola products are not designed, intended, or authorized for use as components in systems intended for surgical implant into the body, or other applications intended to support or sustain life, or for any other application in which the failure of the Motorola product could create a situation where personal injury or death may occur. Should Buyer purchase or use Motorola products for any such unintended or unauthorized application, Buyer shall indemnify and hold Motorola and its officers, employees, subsidiaries, affiliates, and distributors harmless against all claims, costs, damages, and expenses, and reasonable attorney fees arising out of, directly or indirectly, any claim of personal injury or death associated with such unintended or unauthorized use, even if such claim alleges that Motorola was negligent regarding the design or manufacture of the part. Motorola and are registered trademarks of Motorola, Inc. Motorola, Inc. is an Equal Opportunity/Affirmative Action Employer.

How to reach us:

USA/EUROPE/Locations Not Listed: Motorola Literature Distribution;
P.O. Box 5405; Denver, Colorado 80217. 303-675-2140 or 1-800-441-2447

JAPAN: Nippon Motorola Ltd.; Tatsumi-SPD-JLDC, 6F Seibu-Butsuryu-Center,
3-14-2 Tatsumi Koto-Ku, Tokyo 135, Japan. 81-3-3521-8315

Mfax™: RMFAX0@email.sps.mot.com – TOUCHTONE 602-244-6609
INTERNET: http://Design-NET.com

ASIA/PACIFIC: Motorola Semiconductors H.K. Ltd.; 8B Tai Ping Industrial Park,
51 Ting Kok Road, Tai Po, N.T., Hong Kong. 852-26629298