

FAIRCHILD
SEMICONDUCTOR™

August 1993
Revised April 1999

74VHC4040 12-Stage Binary Counter

General Description

The VHC4040 is an advanced high-speed CMOS device fabricated with silicon gate CMOS technology. It achieves the high-speed operation similar to equivalent Bipolar Schottky TTL while maintaining the CMOS low power dissipation. The VHC4040 is a 12-stage counter which increments on the negative edge of the input clock and all outputs are reset to a low level by applying a logical high on the reset input. An input protection circuit insures that 0V to 7V can be applied to the inputs without regard to the supply voltage. This device can be used to interface 5V to 3V systems and two supply systems such as battery

backup. This circuit prevents device destruction due to mismatched supply and input voltages.

Features

- High speed; $f_{MAX} = 210$ MHz at $V_{CC} = 5V$
- Low power dissipation: $I_{CC} = 4 \mu A$ (max) at $T_A = 25^\circ C$
- High noise immunity: $V_{NIH} = V_{NIL} = 28\% V_{CC}$ (min)
- Power down protection is provided on all inputs
- Wide operating voltage range: $V_{CC} (opr) = 2V - 5.5V$
- Low noise: $V_{OLP} = 0.8V$ (max)
- Pin and function compatible with 74HC4040

Ordering Code:

Order Number	Package Number	Package Description
74VHC4040M	M16A	16-Lead Small Outline Integrated Circuit (SOIC), JEDEC MS-012, 0.150" Narrow
74VHC4040MTC	MTC16	16-Lead Thin Shrink Small Outline Package (TSSOP), JEDEC MO-153, 4.4mm Wide
74VHC4040N	N16E	16-Lead Plastic Dual-In-Line Package (PDIP), JEDEC MS-001, 0.300" Wide

Surface mount packages are also available on Tape and Reel. Specify by appending the suffix letter "X" to the ordering code.

Connection Diagram

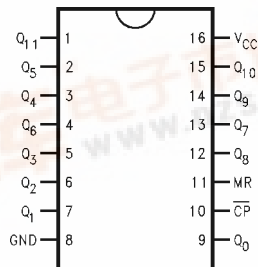

Pin Descriptions

Pin Names	Description
$Q_0 - Q_{11}$	Flip-Flop Outputs
CP	Negative Edged Triggered Clock
MR	Master Reset

74VHC4040 12-Stage Binary Counter



Logic Symbols

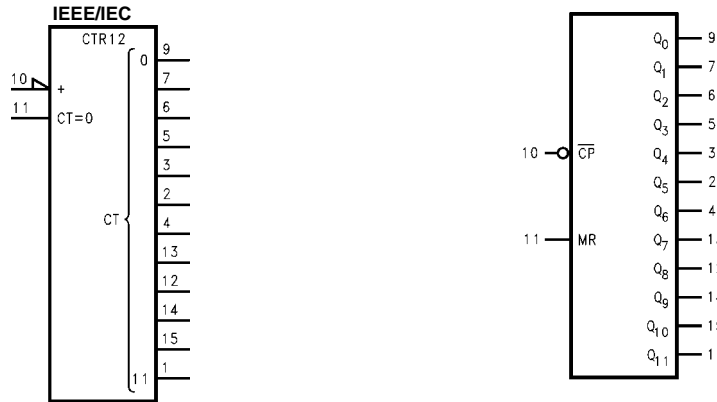

Logic Diagram

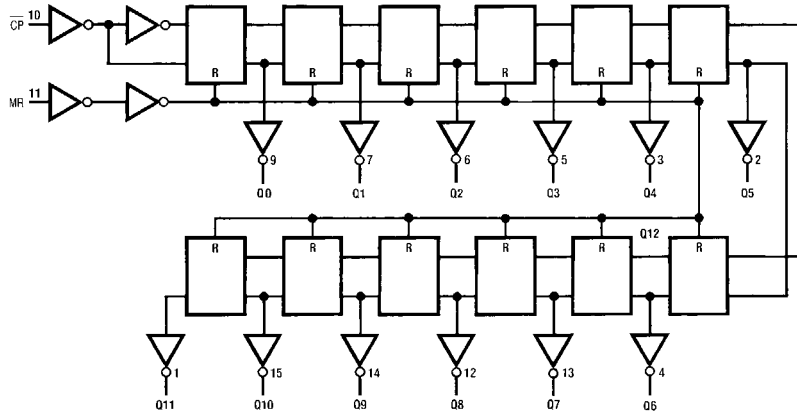

Timing Diagram

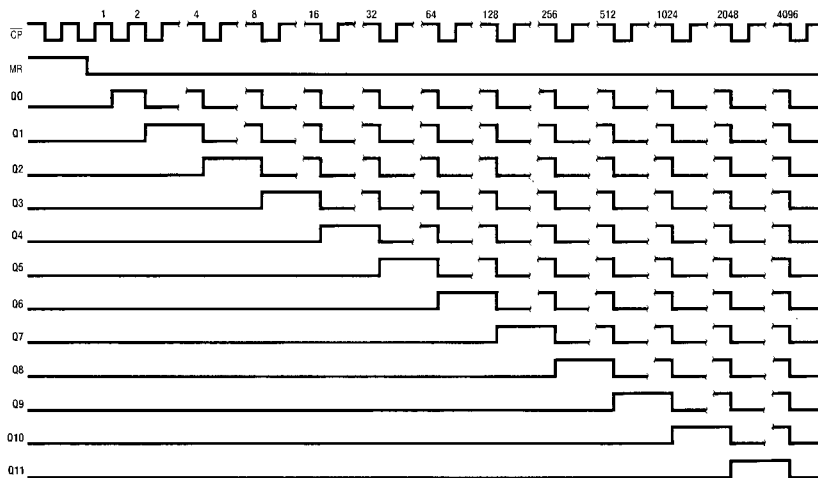

Absolute Maximum Ratings(Note 1)

Supply Voltage (V_{CC})	-0.5V to +7.0V
DC Input Voltage (V_{IN})	-0.5V to +7.0V
DC Output Voltage (V_{OUT})	-0.5V to $V_{CC} + 0.5V$
Input Diode Current (I_{IK})	-20 mA
Output Diode Current (I_{OK})	± 20 mA
DC Output Current (I_{OUT})	± 25 mA
DC V_{CC} /GND Current (I_{CC})	± 75 mA
Storage Temperature (T_{STG})	-65°C to +150°C
Lead Temperature (T_L) (Soldering, 10 seconds)	260°C

Recommended Operating Conditions (Note 2)

Supply Voltage (V_{CC})	2.0V to +5.5V
Input Voltage (V_{IN})	0V to +5.5V
Output Voltage (V_{OUT})	0V to V_{CC}
Operating Temperature (T_{OPR})	-40°C to +85°C
Input Rise and Fall Time (t_r, t_f)	$V_{CC} = 3.3V \pm 0.3V$ $V_{CC} = 5.0V \pm 0.5V$
	0 ~ 100 ns/V 0 ~ 20 ns/V

Note 1: Absolute Maximum Ratings are values beyond which the device may be damaged or have its useful life impaired. The databook specifications should be met, without exception, to ensure that the system design is reliable over its power supply, temperature, and output/input loading variables. Fairchild does not recommend operation outside databook specifications.

Note 2: Unused inputs must be held HIGH or LOW. They may not float

DC Electrical Characteristics

Symbol	Parameter	V_{CC} (V)	$T_A = 25^\circ\text{C}$			$T_A = -40^\circ\text{C to } +85^\circ\text{C}$		Units	Conditions	
			Min	Typ	Max	Min	Max			
V_{IH}	HIGH Level Input Voltage	2.0 3.0 – 5.5	1.50			1.50 0.7 V_{CC}		V		
V_{IL}	LOW Level Input Voltage	2.0 3.0 – 5.5			0.50 0.3 V_{CC}		0.50 0.3 V_{CC}	V		
V_{OH}	HIGH Level Output Voltage	2.0	1.9	2.0		1.9		V	$V_{IN} = V_{IH}$ or V_{IL}	$I_{OH} = -50 \mu\text{A}$
		3.0	2.9	3.0		2.9				$I_{OH} = -4 \text{ mA}$
		4.5	4.4	4.5		4.4				$I_{OH} = -8 \text{ mA}$
		3.0	2.58			2.48				
		4.5	3.94			3.80				
V_{OL}	LOW Level Output Voltage	2.0		0.0	0.1		0.1	V	$V_{IN} = V_{IH}$ or V_{IL}	$I_{OL} = 50 \mu\text{A}$
		3.0		0.0	0.1		0.1			
		4.5		0.0	0.1		0.1			
		3.0			0.36		0.44			
		4.5			0.36		0.44		$I_{OL} = 8 \text{ mA}$	
I_{IN}	Input Leakage Current	0 – 5.5			± 0.1		± 1.0	μA	$V_{IN} = 5.5V$ or GND	
I_{CC}	Quiescent Supply Current	5.5			4.0		40.0	μA	$V_{IN} = V_{CC}$ or GND	

AC Electrical Characteristics

Symbol	Parameter	V _{CC} (V)	T _A = +25°C			T _A = -40°C to +85°C		Units	Conditions
			Min	Typ	Max	Min	Max		
t _{PLH}	Propagation Delay Time to Q ₁	3.3 ± 0.3	7.5	11.9	1.0	14.0	ns	C _L = 15 pF	
t _{PHL}			10.0	15.4	1.0	17.5		C _L = 50 pF	
		5.0 ± 0.5	4.8	7.3	1.0	8.5	ns	C _L = 15 pF	
			6.3	9.3	1.0	10.5		C _L = 50 pF	
t _{PLH}	Propagation Delay Time between Stages from Q _n to Q _{n+1}	3.3 ± 0.3					ns	C _L = 15 pF	
t _{PHL}			2.4	4.4	1.0	5.0		C _L = 50 pF	
		5.0 ± 0.5	1.6	3.1	1.0	3.5	ns	C _L = 15 pF	
								C _L = 50 pF	
t _{PHL}	Propagation Delay Time MR-Q _n	3.3 ± 0.3	8.3	12.8	1.0	15.0	ns	C _L = 15 pF	
			10.8	16.3	1.0	18.5		C _L = 50 pF	
		5.0 ± 0.5	5.6	8.6	1.0	10.0	ns	C _L = 15 pF	
			7.1	10.6	1.0	12.0		C _L = 50 pF	
f _{MAX}	Maximum Clock Frequency	3.3 ± 0.3	90	140	75		MHz	C _L = 15 pF	
			55	80	50			C _L = 50 pF	
		5.0 ± 0.5	150	210	125		MHz	C _L = 15 pF	
			95	125	80			C _L = 50 pF	
C _{IN}	Input Capacitance		4	10		10	pF	V _{CC} = Open	
C _{PD}	Power Dissipation Capacitance		21				pF	(Note 3)	

Note 3: C_{PD} is defined as the value of the internal equivalent capacitance which is calculated from the operating current consumption without load. Average operating current can be obtained by the equation: I_{CC (opr)} = C_{PD} * V_{CC} * f_N + I_{CC}.

AC Operating Requirements

Symbol	Parameter	V _{CC} (V)	T _A = 25°C	T _A = -40°C to +85°C		Units
			Typ	Guaranteed Minimum		
t _{w(L)}	Minimum Pulse Width	3.3 ± 0.3		5.0	5.0	ns
t _{w(H)}	(CP)	5.0 ± 0.5		5.0	5.0	
t _{w(L)}	Minimum Pulse Width	3.3 ± 0.3		5.0	5.0	ns
	(MR)	5.0 ± 0.5		5.0	5.0	
t _{REC}	Minimum Removal Time	3.3 ± 0.3		5.0	5.0	ns
	(MR)	5.0 ± 0.5		5.0	5.0	

Physical Dimensions inches (millimeters) unless otherwise noted

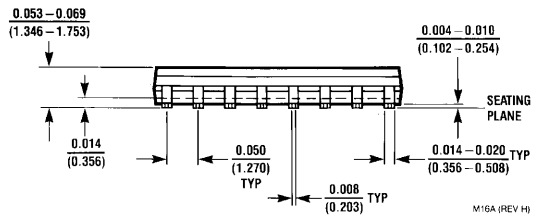
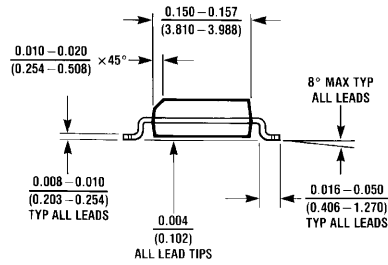
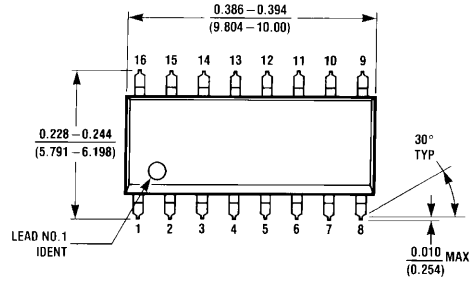

**16-Lead Small Outline Integrated Circuit (SOIC), JEDEC MS-012, 0.150" Narrow
Package Number M16A**

Physical Dimensions inches (millimeters) unless otherwise noted (Continued)

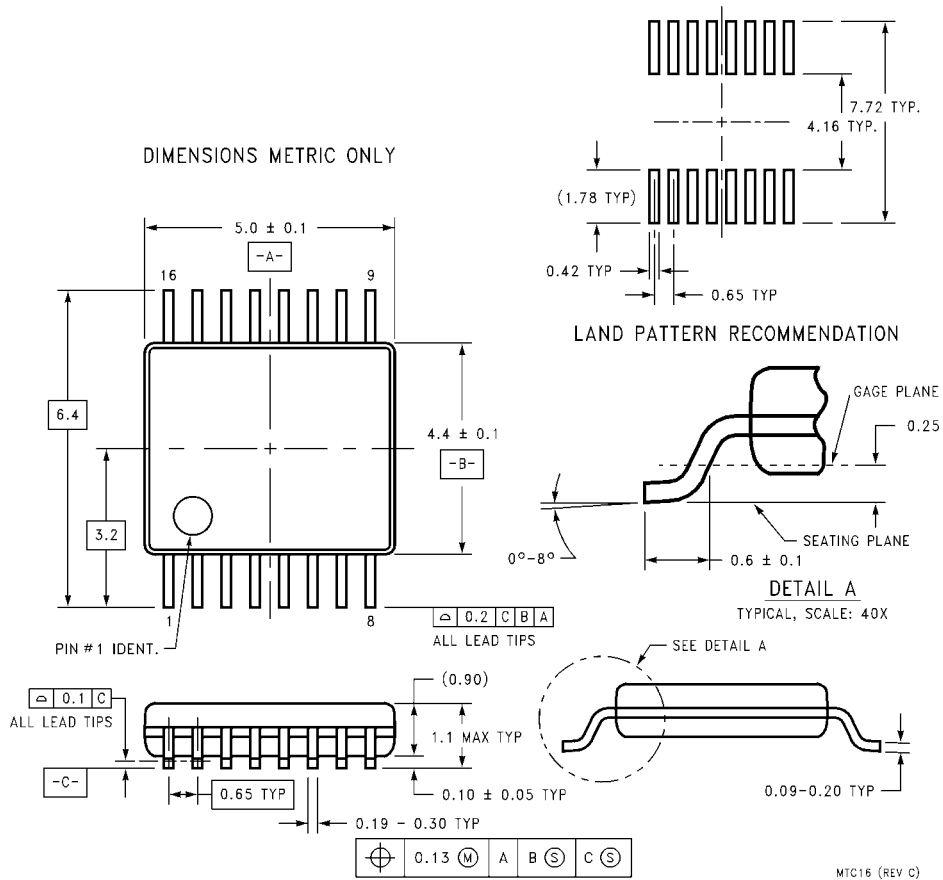

**16-Lead Thin Shrink Small Outline Package (TSSOP), JEDEC MO-153, 4.4mm Wide
Package Number MTC16**

Physical Dimensions inches (millimeters) unless otherwise noted (Continued)

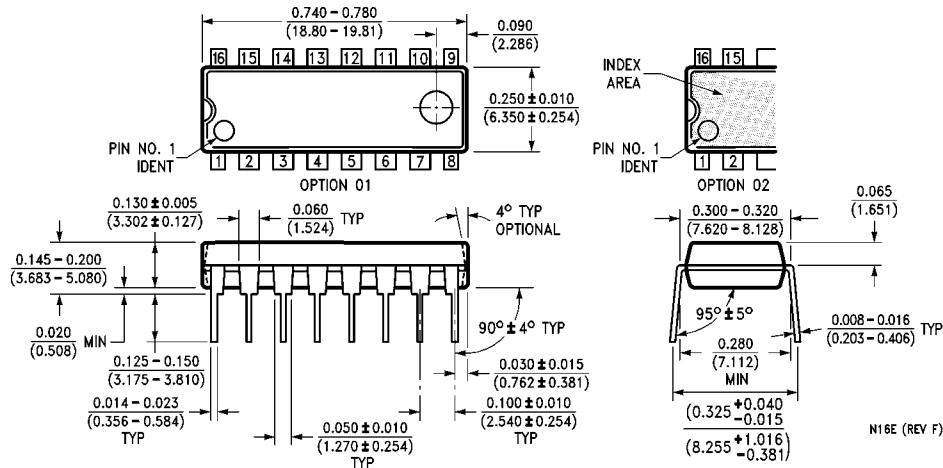

**16-Lead Plastic Dual-In-Line Package (PDIP), JEDEC MS-001, 0.300" Wide
Package Number N16E**

LIFE SUPPORT POLICY

FAIRCHILD'S PRODUCTS ARE NOT AUTHORIZED FOR USE AS CRITICAL COMPONENTS IN LIFE SUPPORT DEVICES OR SYSTEMS WITHOUT THE EXPRESS WRITTEN APPROVAL OF THE PRESIDENT OF FAIRCHILD SEMICONDUCTOR CORPORATION. As used herein:

1. Life support devices or systems are devices or systems which, (a) are intended for surgical implant into the body, or (b) support or sustain life, and (c) whose failure to perform when properly used in accordance with instructions for use provided in the labeling, can be reasonably expected to result in a significant injury to the user.
2. A critical component in any component of a life support device or system whose failure to perform can be reasonably expected to cause the failure of the life support device or system, or to affect its safety or effectiveness.

www.fairchildsemi.com