

MAXIM

MAX1165 Evaluation Kit

General Description

The MAX1165 evaluation kit (EV kit) is an assembled and tested circuit board that demonstrates the MAX1165 analog-to-digital converter. The EV kit can also evaluate the MAX1065/MAX1066 and MAX1165/MAX1166. Request free samples of the desired parts when ordering the MAX1165 EV kit.

Component List

DESIGNATION	QTY	DESCRIPTION
C1, C2, C11, C12	4	10µF, 10V X7R ceramic capacitors Taiyo Yuden LMK325BJ106MN
C3, C4, C5, C8, C9, C10	6	0.1µF, 10V X7R ceramic capacitors
C6	1	4.7µF, 10V X7R ceramic capacitor Taiyo Yuden JMK212BJ475KG
C7	1	0.01µF ceramic capacitor
C7, R2	4	Socket-pin receptacles
H1	1	2 × 16 dual-row vertical header
JU1–JU6	6	2-pin headers
R1	1	100kΩ ±5% resistor
R2	1	4.7Ω ±5% resistor
U1	1	MAX1165BEUI
U2	1	Hex Schmitt trigger buffer 74HC14
U3	1	MAX4430ESA
None	1	MAX1165 EV kit PC board
None	1	MAX1165 data sheet
None	1	MAX1165 EV kit data sheet

Component Supplier

SUPPLIER	PHONE	FAX	WEBSITE
Taiyo Yuden	800-348-2496	847-925-0899	www.t-yuden.com

Note: Please indicate that you are using the MAX1165 when contacting these component suppliers.

Features

- ◆ Proven PC Board Layout
- ◆ Convenient On-Board Test Points
- ◆ Fully Assembled and Tested

Ordering Information

PART	TEMP RANGE	IC PACKAGE
MAX1165EVKIT	0°C to +70°C	28 TSSOP

Quick Start

Recommended Equipment

- MAX1165 EV kit
- Two DC power supplies, 5V at 10mA
- Programmable signal generator, such as Tektronix DG2020A
- Logic analyzer (optional)
- Reconstruction DAC (optional)

Procedure

The MAX1165 EV kit is fully assembled and tested. Follow these steps to verify board operation. **Do not turn on the power supply until all connections are completed.**

- 1) Ensure that JU1, JU2, and JU3 are open (see Table 1).
- 2) With the power off, connect the first 5VDC power supply between AVDD and AGND.
- 3) With the power off, connect the second 5VDC power supply between DVDD and DGND. **Note:** DGND and AGND are connected on the MAX1165 EV kit board. To avoid ground loops, do not connect AGND to DGND at any other location.
- 4) Configure the pattern generator to produce the appropriate read/convert (R/C) and conversion start (CS) waveforms. Refer to Figure 2 in the MAX1165 data sheet.
- 5) Connect the pattern generator \overline{CS} output across jumper JU4.
- 6) Connect the pattern generator R/C output across jumper JU5.
- 7) Connect logic analyzer or other digital data capture system to header H1. The least significant bit, D0, appears on H1 pin 1, and the end-of-conversion output strobe (EOC) appears across jumper JU6 (see Table 2).
- 8) Turn on the power supplies and enable the pattern generator.
- 9) Apply 0 to 4.096V analog input signal between pads AIN and AGND. Capture digital data from header H1.

Evaluates: MAX1165/MAX1166/MAX1065/MAX1066



MAX1165 Evaluation Kit

Detailed Description of Hardware

The MAX1165 (U1) is a single-channel, 16-bit data-acquisition system. Anti-alias filtering is performed by R2 and C7. The input signal can be applied directly to the AIN pad, or an optional MAX4430 precision buffer (U3) can be used instead. Capacitors C4 and C6 bypass the reference. Schmitt trigger (U2) ensures proper system timing by keeping the \overline{CS} rising and falling edges clean.

Analog Input Buffer

When powered from $\pm 5V$ supplies, the analog input buffer (U3) has an input common-mode range of -2.5V to +4.1V.

- 1) With the power off, connect the +5VDC power supply between BUF+5 and AGND.
- 2) With the power off, connect the -5VDC power supply between BUF-5 and AGND.
- 3) With the power off, connect the DC power supply ground return to AGND.
- 4) Install a shunt across jumper JU3.
- 5) Apply analog input signal to BUFIN pad.

If the full unipolar 0 to 5V range is needed, apply +7V to BUF+5 and -3V to BUF-5. The input common-mode range is -0.5V to +6.1V.

Generating a Crossplot

To see a visual indication of relative LSB size and DNL performance, create a crossplot fixture using a function generator, a latch, a resistor network, and an oscilloscope. Latch the data on the falling edge of \overline{EOC} . Connect the least significant bits together, using resistors of varying weights (for example, D0 = $75.0k\Omega \pm 1\%$, D1 = $39.1k\Omega \pm 1\%$, D2 = $20.0k\Omega \pm 1\%$, D3 = $10.0k\Omega \pm 1\%$, D4 = $4.99k\Omega \pm 1\%$). Drive the analog inputs with a linear ramping signal, such as a 100Hz triangle wave. Connect an oscilloscope in X-Y mode with X = analog input and Y = weighted sum of the latched digital outputs. The resulting staircase plot gives a visual indication of relative LSB sizes and DNL performance.

Evaluating the MAX1165/MAX1166 and MAX1065/MAX1066

The MAX1166 has an 8-bit interface. Its high-byte enable (HBEN) is on the pad labeled RESET. To evaluate the MAX1166, request a free sample of the MAX1166BEUP. Remove the MAX1165 and install the MAX1166, leaving U1 pins 1–4 and 25–28 unconnected.

The MAX1065 is a 14-bit version of the MAX1165. To evaluate the MAX1065, request a free sample of the MAX1065AEUI. Remove the MAX1165 and install the MAX1065.

The MAX1066 is a 14-bit version of the MAX1165, with an 8-bit interface. Its high-byte enable (HBEN) is on the pad labeled RESET. To evaluate the MAX1066, request a free sample of the MAX1066AEUP. Remove the MAX1165 and install the MAX1066, leaving U1 pins 1–4 and 25–28 unconnected.

See Table 2 for device comparison.

Troubleshooting

Problem: no output measurement. System seems to report zero voltage, or fails to make a measurement.

Check AVDD and DVDD supply voltages. Check the 4.096V reference voltage using a digital voltmeter. Use an oscilloscope to verify the R/C, \overline{CS} , and \overline{EOC} signals.

Ensure that a resistor is installed in socket R2; otherwise, the analog input is unconnected.

If using the input buffer U3, ensure that the $\pm 5V$ power supply is connected and JU3 is closed.

Problem: measurements are erratic, unstable; poor accuracy.

Check the reference voltage using a digital voltmeter. Use an oscilloscope to check for noise. When probing for noise, keep the oscilloscope ground return lead as short as possible, preferably less than 1/2in (10mm).

Increase C6 and C7 capacitance. Short JU1 and apply an external 4.096V reference at REF to improve accuracy.

Check for ground loops in your system.

MAX1165 Evaluation Kit

Evaluates: MAX1165/MAX1166/MAX1065/MAX1066

Table 1. Jumper Functions

JUMPER	FUNCTION
JU1	Leave JU1 open to enable the internal reference. Short JU1 when applying an external reference at REF.
JU2	Momentarily short JU2 to reset U1 (MAX1165/MAX1065 only). Leave JU2 open and apply high-byte enable signal (HBEN) at the RESET pad (MAX1166/MAX1066 only).
JU3	Short JU3 to drive analog input from MAX4430 buffer U3. Leave JU3 open when driving AIN directly through R2.
JU4	Apply conversion start signal (\overline{CS}) across JU4
JU5	Apply read/convert signal (R/\overline{C}) across JU5
JU6	Obtain end-of-conversion (\overline{EOC}) signal from JU6

Table 2. Device Comparison

PART	MAX1165	MAX1166	MAX1065	MAX1066
RESOLUTION	16 bit	16 bit	14 bit	14 bit
INTERFACE WIDTH	16 bit	8 bit	16 bit	8 bit
H1-1 signal	D0	D0/D8	Not used	D0/D8
H1-3 signal	D1	D1/D9	Not used	D1/D9
H1-5 signal	D2	D2/D10	D0	D2/D10
H1-7 signal	D3	D3/D11	D1	D3/D11
H1-9 signal	D4	Not used	D2	Not used
H1-11 signal	D5	Not used	D3	Not used
H1-13 signal	D6	Not used	D4	Not used
H1-15 signal	D7	Not used	D5	Not used
H1-17 signal	D8	Not used	D6	Not used
H1-19 signal	D9	Not used	D7	Not used
H1-21 signal	D10	Not used	D8	Not used
H1-23 signal	D11	Not used	D9	Not used
H1-25 signal	D12	D4/D12	D10	D4/D12
H1-27 signal	D13	D5/D13	D11	D5/D13
H1-29 signal	D14	D6/D14	D12	D6/0
H1-31 signal	D15	D7/D15	D13	D7/0
RESET pad	RESET	HBEN	RESET	HBEN

MAX1165 Evaluation Kit

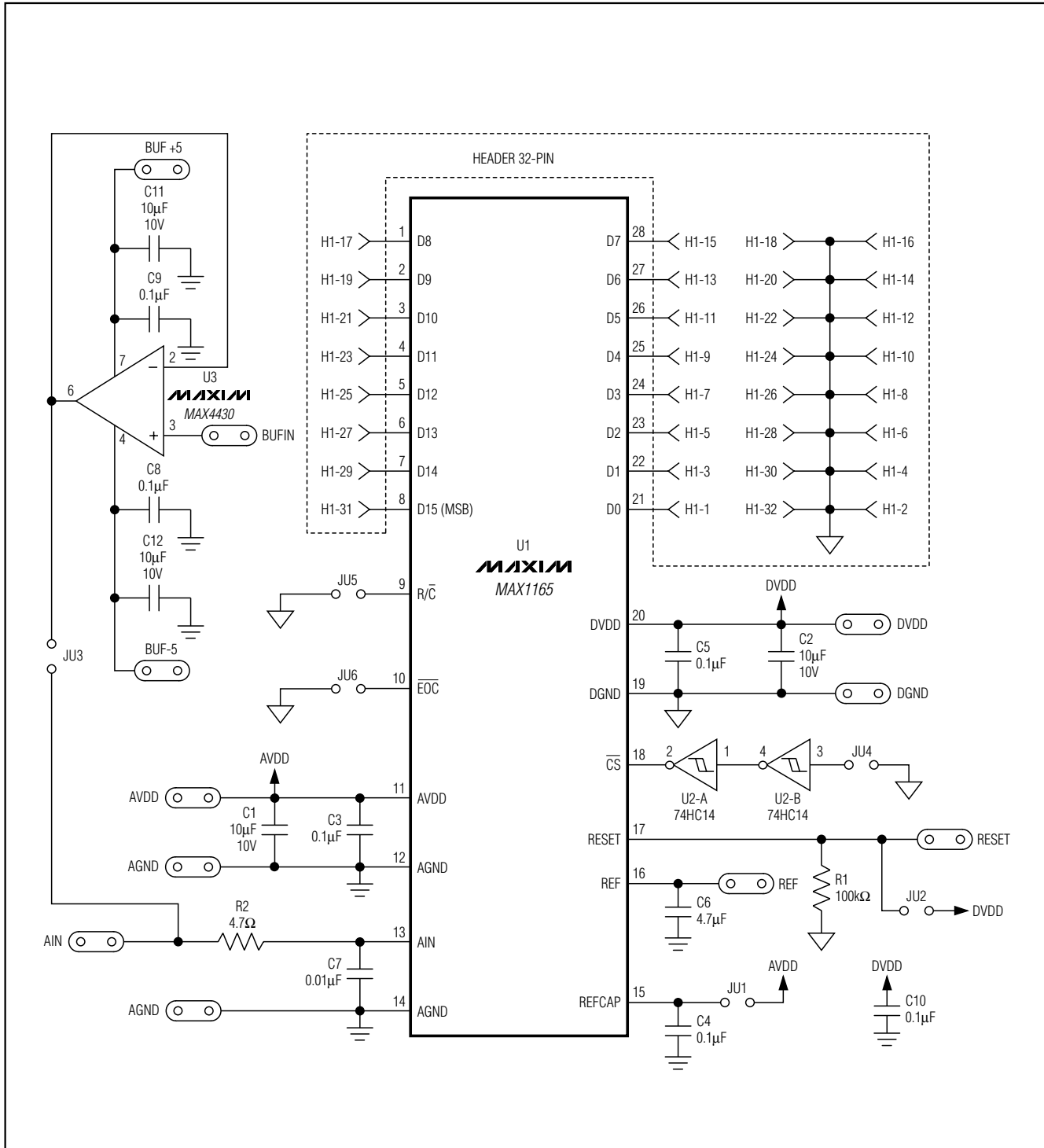

Figure 1. MAX1165 EV Kit Schematic

MAX1165 Evaluation Kit

Evaluates: MAX1165/MAX1166/MAX1065/MAX1066

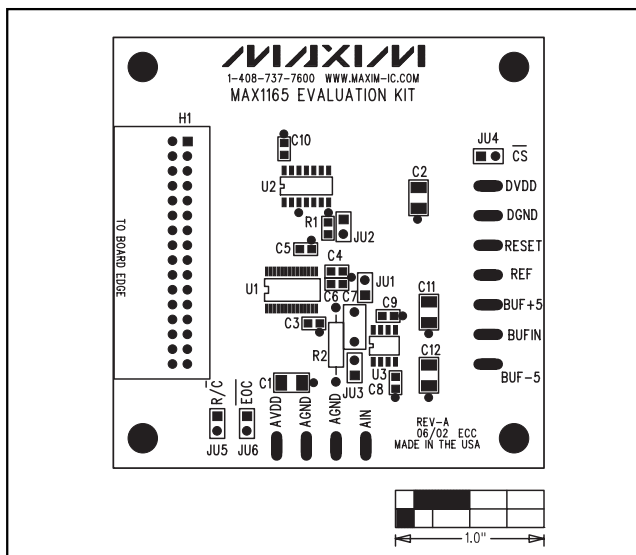

Figure 2. MAX1165 EV Kit Component Placement Guide—Component Side

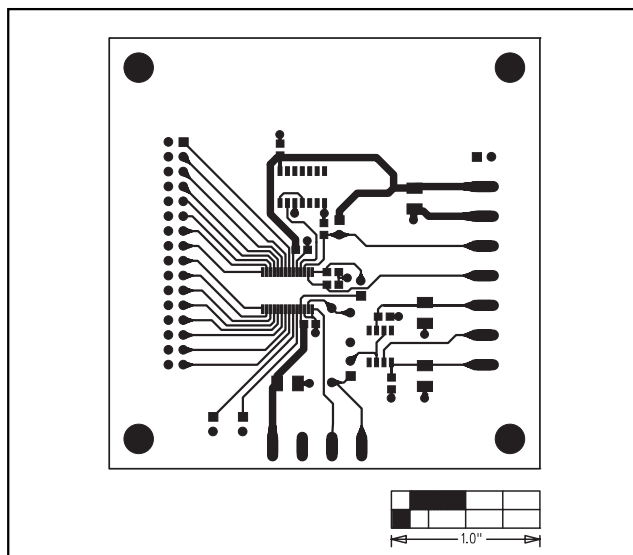

Figure 3. MAX1165 EV Kit PC Board Layout—Component Side

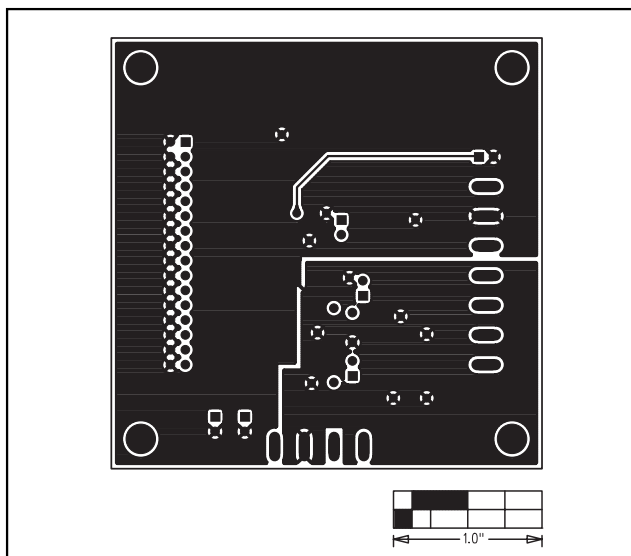

Figure 4. MAX1165 EV Kit PC Board Layout—Solder Side

Maxim cannot assume responsibility for use of any circuitry other than circuitry entirely embodied in a Maxim product. No circuit patent licenses are implied. Maxim reserves the right to change the circuitry and specifications without notice at any time.

Maxim Integrated Products, 120 San Gabriel Drive, Sunnyvale, CA 94086 408-737-7600 _____ 5