



# VN02ANSP

## HIGH SIDE SMART POWER SOLID STATE RELAY

TYPE	V <sub>DSS</sub>	R <sub>DS(on)</sub>	I <sub>OUT</sub>	V <sub>CC</sub>
VN02ANSP	60 V	0.35 Ω	7 A	36 V

- OUTPUT CURRENT (CONTINUOUS):  
7A @ T<sub>c</sub>=25°C
- LOGIC LEVEL 5V COMPATIBLE INPUT
- THERMAL SHUT-DOWN
- UNDER VOLTAGE PROTECTION
- OPEN DRAIN DIAGNOSTIC OUTPUT
- FAST DEMAGNETIZATION OF INDUCTIVE LOAD

### DESCRIPTION

The VN02ANSP is a monolithic device made using STMicroelectronics VIPower Technology, intended for driving resistive or inductive loads with one side grounded.

Built-in thermal shut-down protects the chip from over temperature and short circuit. The diagnostic output indicates an over temperature status.

Fast turn-off of inductive load is achieved by negative (-18 V) load voltage at turn-off.

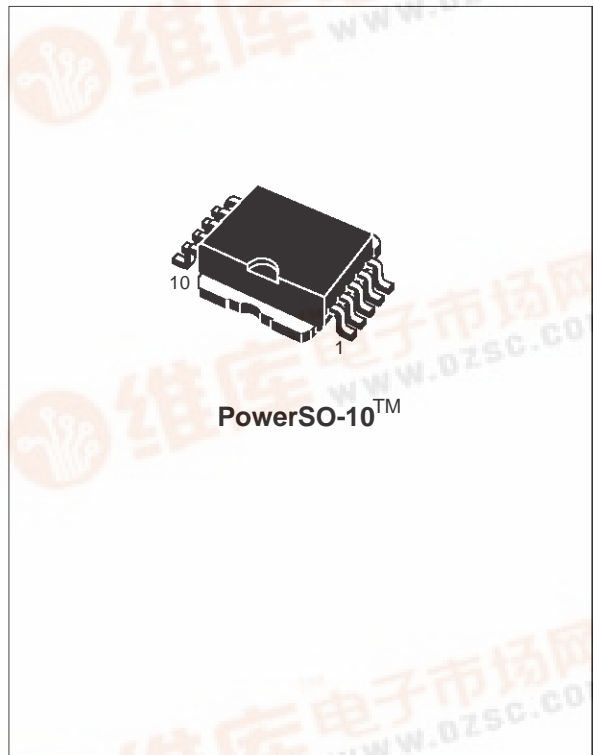

### BLOCK DIAGRAM

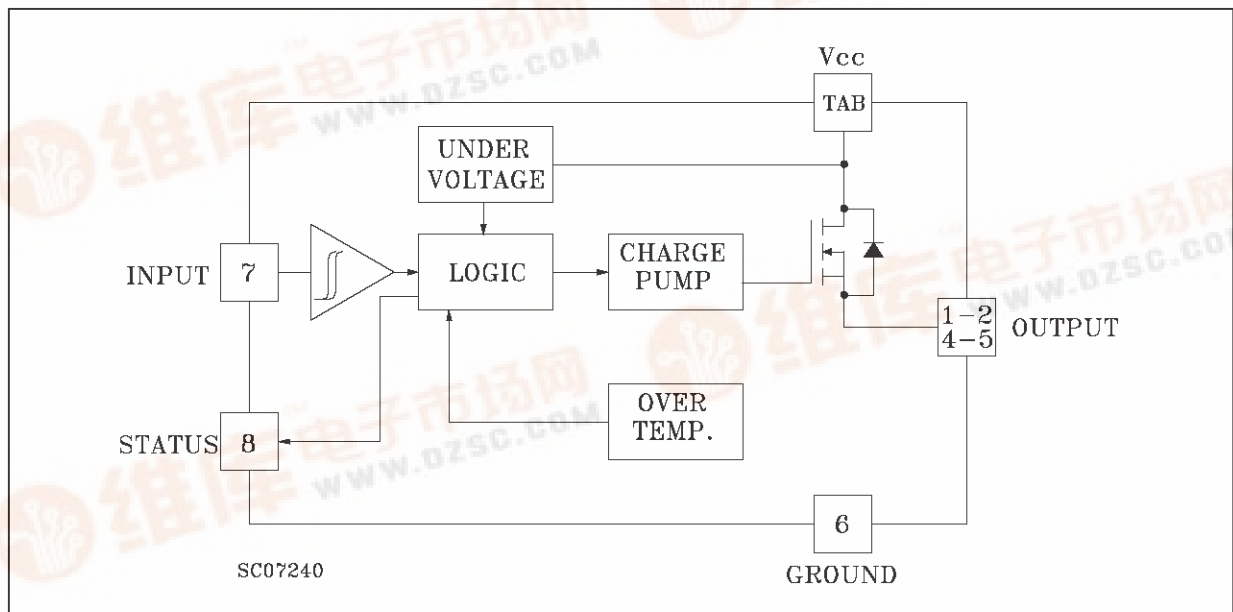

# VN02ANSP

## ABSOLUTE MAXIMUM RATING

Symbol	Parameter	Value	Unit
$V_{(BR)DSS}$	Drain-Source Breakdown Voltage	60	V
$I_{OUT}$	Output Current (cont.)	7	A
$I_R$	Reverse Output Current	-7	A
$I_{IN}$	Input Current	$\pm 10$	mA
$-V_{CC}$	Reverse Supply Voltage	-4	V
$I_{STAT}$	Status Current (sink)	$\pm 10$	mA
$V_{ESD}$	Electrostatic Discharge (1.5 k $\Omega$ , 100 pF)	2000	V
$P_{tot}$	Power Dissipation at $T_c \leq 25$ °C	31	W
$T_j$	Junction Operating Temperature	-40 to 150	°C
$T_{stg}$	Storage Temperature	-55 to 150	°C

## CONNECTION DIAGRAMS

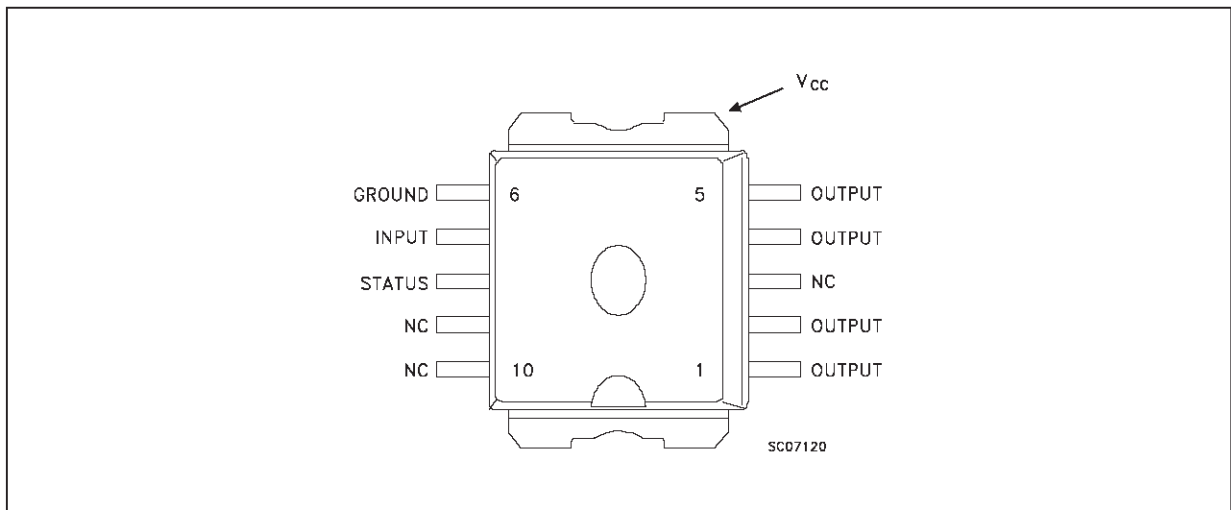

## CURRENT AND VOLTAGE CONVENTIONS

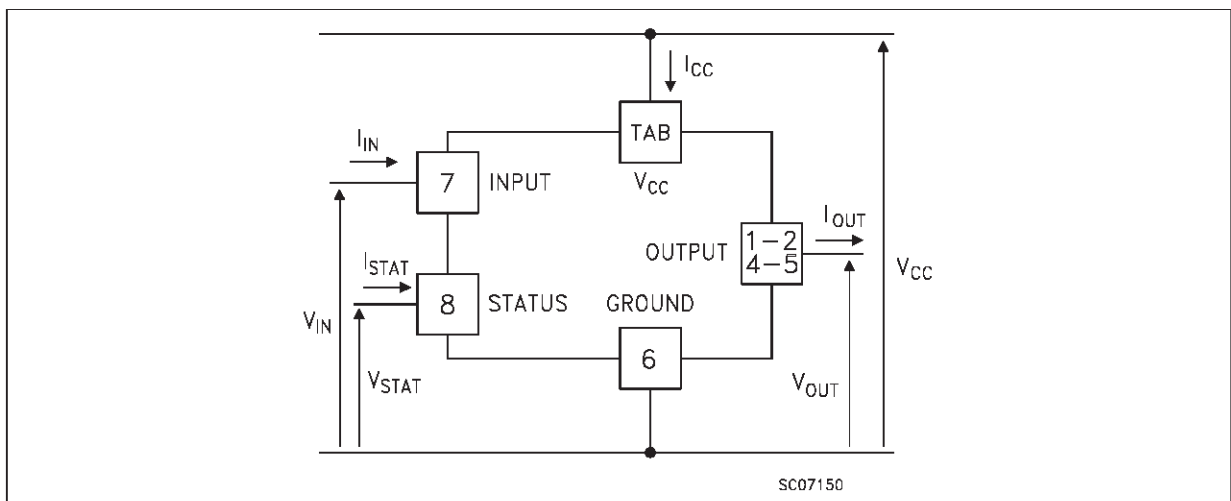

## THERMAL DATA

$R_{thj-case}$	Thermal Resistance Junction-case	Max	4	$^{\circ}C/W$
$R_{thj-amb}$	Thermal Resistance Junction-ambient (\$)	Max	50	$^{\circ}C/W$

(\$) When mounted using minimum recommended pad size on FR-4 board

ELECTRICAL CHARACTERISTICS ( $V_{CC} = 9$  to  $36$  V;  $T_{case} = 25$   $^{\circ}C$  unless otherwise specified)

## POWER

Symbol	Parameter	Test Conditions	Min.	Typ.	Max.	Unit
$V_{CC}$ *	Supply Voltage	$-40$ $^{\circ}C < T_j < 125$ $^{\circ}C$	7		36	V
$R_{on}$	On State Resistance	$I_{OUT} = 3$ A $I_{OUT} = 1$ A $V_{CC} = 30$ V $T_j = 125$ $^{\circ}C$			0.35 0.6	$\Omega$ $\Omega$
$I_s$	Supply Current	Off State $V_{CC} = 30$ V On State $V_{CC} = 30$ V On State $V_{CC} = 30$ V $T_j = 125$ $^{\circ}C$			1 9 7	mA mA mA

## SWITCHING

Symbol	Parameter	Test Conditions	Min.	Typ.	Max.	Unit
$t_{d(on)}$	Turn-on Delay Time Of Output Current	$I_{OUT} = 3$ A Resistive Load Input Rise Time $< 0.1$ $\mu s$		15		$\mu s$
$t_r$	Rise Time Of Output Current	$I_{OUT} = 3$ A Resistive Load Input Rise Time $< 0.1$ $\mu s$		15		$\mu s$
$t_{d(off)}$	Turn-off Delay Time Of Output Current	$I_{OUT} = 3$ A Resistive Load Input Rise Time $< 0.1$ $\mu s$		14		$\mu s$
$t_f$	Fall Time Of Output Current	$I_{OUT} = 3$ A Resistive Load Input Rise Time $< 0.1$ $\mu s$		4.5		$\mu s$
$(di/dt)_{on}$	Turn-on Current Slope	$I_{OUT} = 3$ A $25$ $^{\circ}C < T_j < 125$ $^{\circ}C$ $I_{OUT} = I_{OV}$ $25$ $^{\circ}C < T_j < 125$ $^{\circ}C$			0.5 1	A/ $\mu s$ A/ $\mu s$
$(di/dt)_{off}$	Turn-off Current Slope	$I_{OUT} = 3$ A $25$ $^{\circ}C < T_j < 125$ $^{\circ}C$ $I_{OUT} = I_{OV}$ $25$ $^{\circ}C < T_j < 125$ $^{\circ}C$			1.5 4	A/ $\mu s$ A/ $\mu s$
$V_{DEMAG}$	Inductive Load Clamp Voltage	$I_{OUT} = 3$ A $-40$ $^{\circ}C < T_j < 125$ $^{\circ}C$	-24	-18	-14	V

LOGIC INPUT ( $-40$   $^{\circ}C \leq T_j \leq 125$   $^{\circ}C$  unless otherwise specified)

Symbol	Parameter	Test Conditions	Min.	Typ.	Max.	Unit
$V_{IL}$	Input Low Level Voltage				0.8	V
$V_{IH}$	Input High Level Voltage		2		(*)	V
$V_{I(hyst.)}$	Input Hysteresis Voltage			0.5		V
$I_{IN}$	Input Current	$V_{IN} = 5$ V $V_{IN} = 2$ V $V_{IN} = 0.8$ V	25	250	600 300	$\mu A$ $\mu A$ $\mu A$
$V_{ICL}$	Input Clamp Voltage	$I_{IN} = 10$ mA $I_{IN} = -10$ mA	5.5	6 -0.7	-0.3	V V

## VN02ANSP

### ELECTRICAL CHARACTERISTICS (continued)

PROTECTION AND DIAGNOSTICS ( $-40\text{ }^{\circ}\text{C} \leq T_j \leq 125\text{ }^{\circ}\text{C}$  unless otherwise specified)

Symbol	Parameter	Test Conditions	Min.	Typ.	Max.	Unit
V <sub>STAT</sub>	Status Voltage Output Low	I <sub>STAT</sub> = 1.6 mA			0.4	V
I <sub>STAT</sub>	Status Leakage Current	V <sub>STAT</sub> = 5 V			10	μA
V <sub>USD</sub>	Under Voltage Shut Down		3.5	6	7	V
V <sub>SCL</sub>	Status Clamp Voltage	I <sub>STAT</sub> = 10 mA I <sub>STAT</sub> = -10 mA	5.5	6 -0.7	-0.3	V V
I <sub>OV</sub>	Over Current	R <sub>LOAD</sub> < 10 mΩ		15		A
I <sub>av</sub>	Average Current In Short Circuit	R <sub>LOAD</sub> < 10 mΩ    T <sub>c</sub> = 85 °C		0.6		A
I <sub>DOFF</sub>	Leakage Current	V <sub>CC</sub> = 30 V			1	mA
T <sub>TSD</sub>	Thermal Shut-down Temperature		140			°C
T <sub>R</sub>	Reset Temperature		125			°C

(\*) The V<sub>ih</sub> is internally clamped at about 6V. It is possible to connect this pin to a higher voltage via an external resistor calculated to not exceed 10 mA at the input pin.

### TRUTH TABLE

	INPUT	DIAGNOSTIC	OUTPUT
Normal Operation	L	H	L
	H	H	H
Over-temperature	H	L	L
Under-voltage	X	H	L

Figure 1: Waveforms

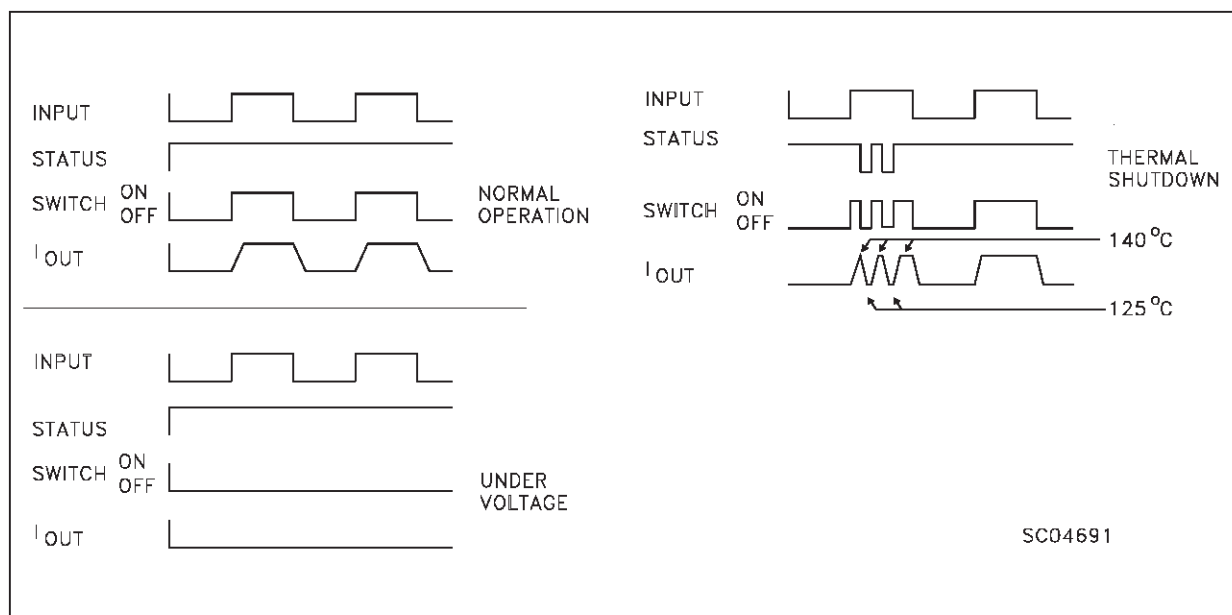

## FUNCTIONAL DESCRIPTION

The device has a diagnostic output which indicates over temperature conditions.

The truth table shows input, diagnostic output status and output voltage level in normal operation and fault conditions. The output signals are processed by internal logic.

To protect the device against short circuit and over current conditions, the thermal protection turns the integrated Power MOS off at a minimum junction temperature of 140 °C. When the temperature returns to 125 °C the switch is automatically turned on again. To ensure the protection in all  $V_{CC}$  conditions and in all the junction temperature range it is necessary to limit the voltage drop across Drain and Source (pin 3 and 5) at 28V according to:

$$V_{ds} = V_{CC} - I_{ov} * (R_i + R_w + R_l)$$

where:

$R_i$  = internal resistance of Power Supply

$R_w$  = Wires resistance

$R_l$  = Short Circuit resistance

Driving inductive loads, an internal function of the device ensures the fast demagnetization with typical voltage ( $V_{demag}$ ) of -18V.

This function allows the reduction of the power dissipation according to the formula:

$$P_{dem} = 0.5 * I_{load} * (I_{load})^2 * [(V_{CC} + V_{dem})/V_{dem}] * f$$

where  $f$  = Switching Frequency

Based on this formula it is possible to know the value of inductance and/or current to avoid a thermal shut-down.

## PROTECTING THE DEVICE AGAINST REVERSE BATTERY

The simplest way to protect the device against a continuous reverse battery voltage (-36V) is to insert a Schottky diode between pin 1 (GND) and ground, as shown in the typical application circuit (Fig. 3). The consequences of the voltage drop across this diode are as follows:

If the input is pulled to power GND, a negative voltage of  $-V_f$  is seen by the device. ( $V_{il}$ ,  $V_{ih}$  thresholds and  $V_{stat}$  are increased by  $V_f$  with respect to power GND).

The undervoltage shut-down level is increased by  $V_f$ .

If there is no need for the control unit to handle external analog signals referred to the power GND, the best approach is to connect the reference potential of the control unit to node [1] (see application circuit in fig. 4), which becomes the common signal GND for the whole control board avoiding shift of  $V_{ih}$ ,  $V_{il}$  and  $V_{stat}$ . This solution allows the use of a standard diode.

**Figure 2:** Over Current Test Circuit

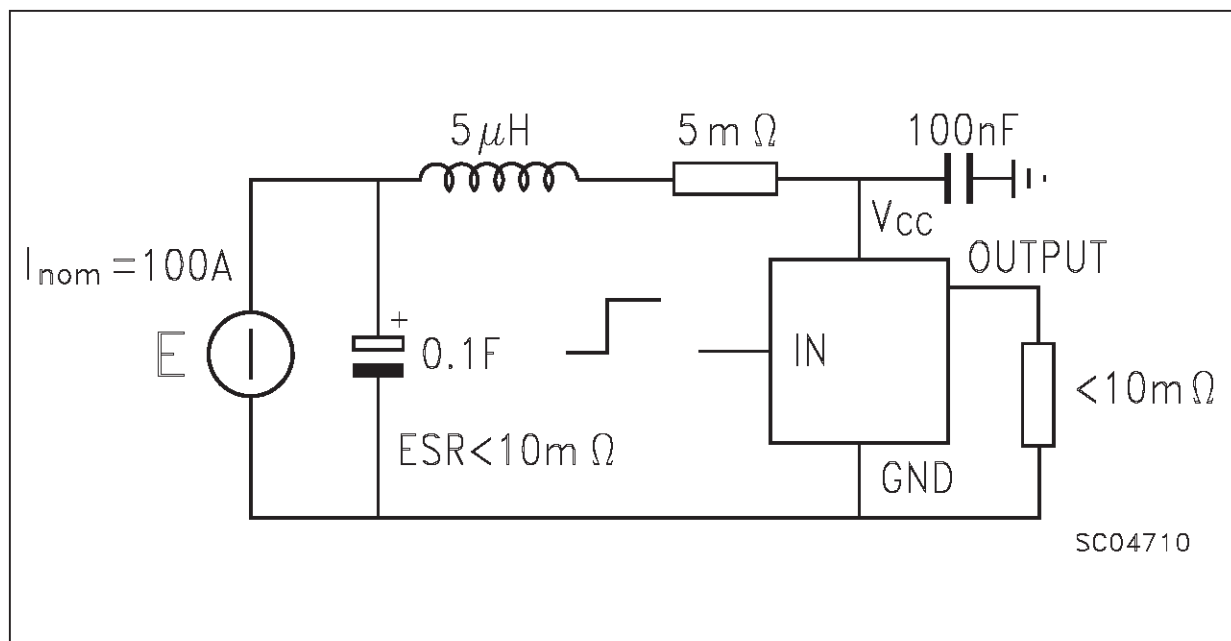

Figure 3: Typical Application Circuit With A Schottky Diode For Reverse Supply Protection

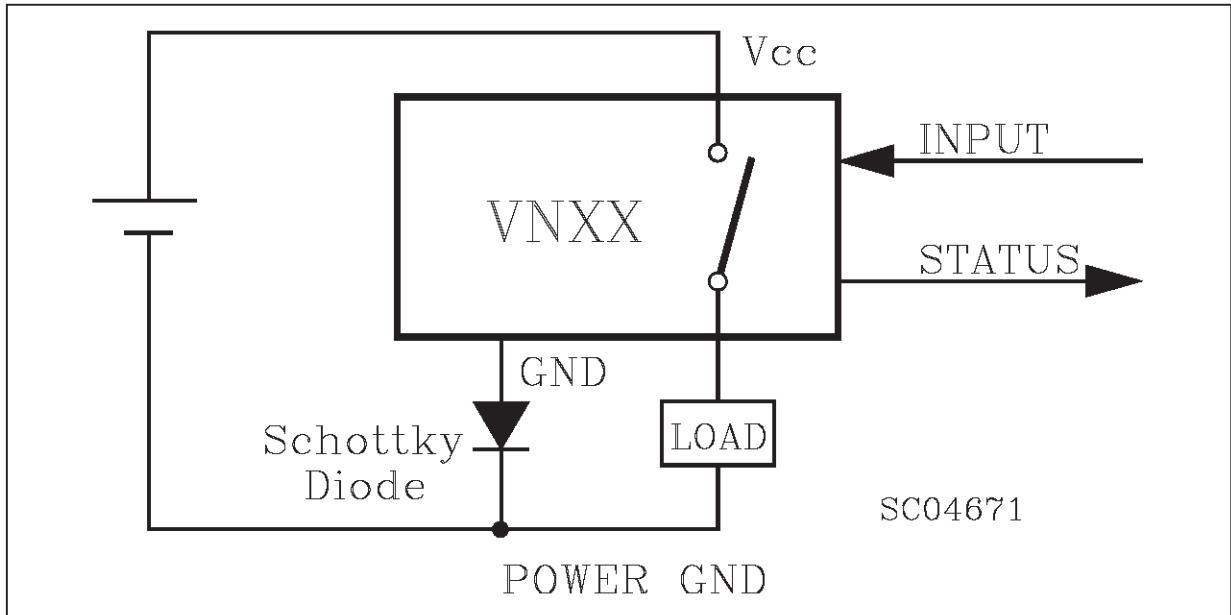
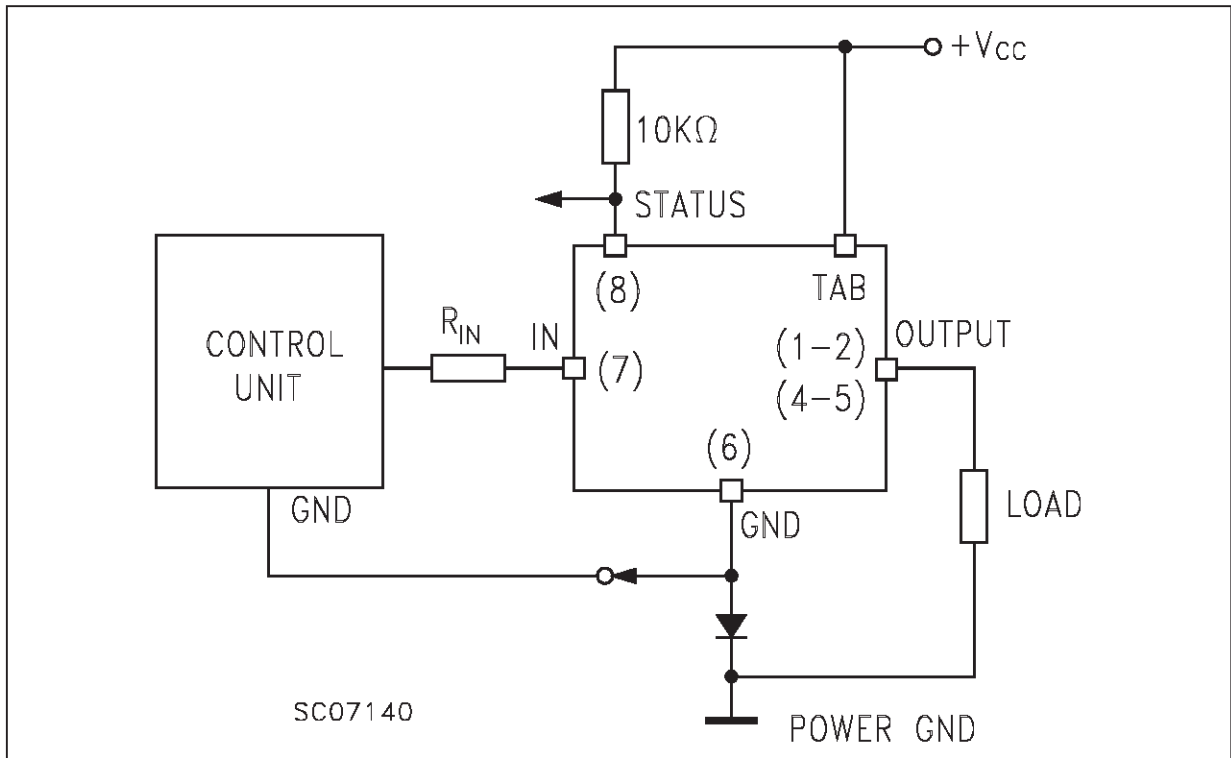
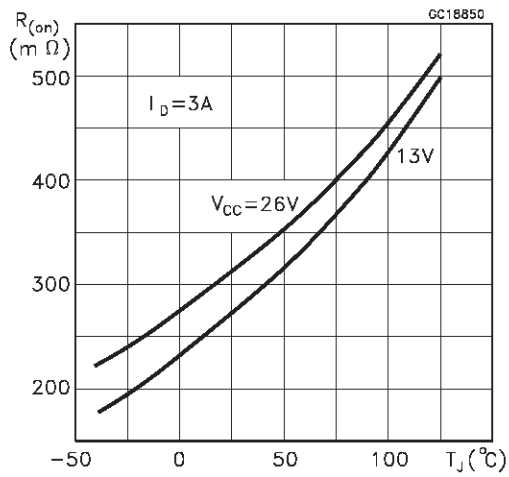

Figure 4: Typical Application Circuit With Separate Signal Ground



$R_{DS(on)}$  vs Junction Temperature



$R_{DS(on)}$  vs Supply Voltage

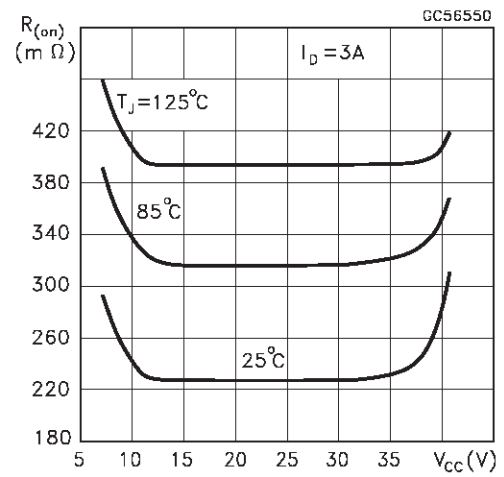

$R_{DS(on)}$  vs Output Current

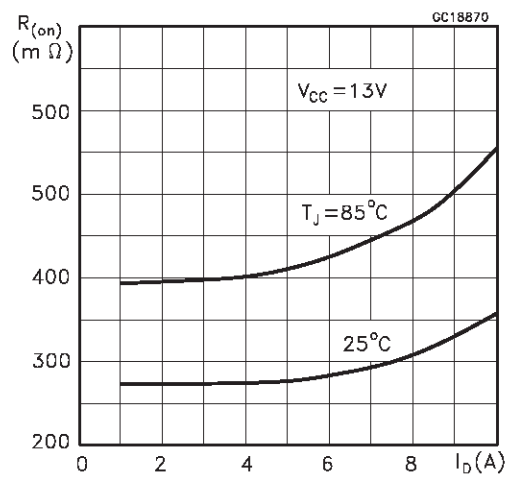

Input Voltages vs Junction Temperature

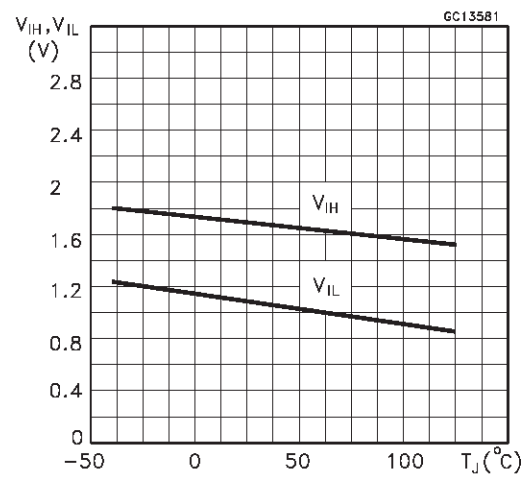

Output Current Derating

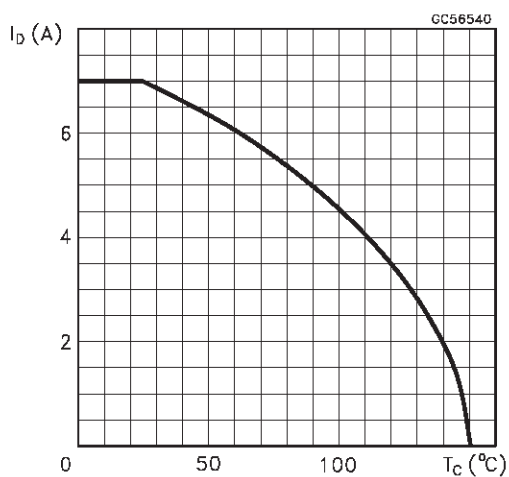

**PowerSO-10 MECHANICAL DATA**

DIM.	mm			inch		
	MIN.	TYP.	MAX.	MIN.	TYP.	MAX.
A	3.35		3.65	0.132		0.144
A1	0.00		0.10	0.000		0.004
B	0.40		0.60	0.016		0.024
c	0.35		0.55	0.013		0.022
D	9.40		9.60	0.370		0.378
D1	7.40		7.60	0.291		0.300
E	9.30		9.50	0.366		0.374
E1	7.20		7.40	0.283		0.291
E2	7.20		7.60	0.283		0.300
E3	6.10		6.35	0.240		0.250
E4	5.90		6.10	0.232		0.240
e		1.27			0.050	
F	1.25		1.35	0.049		0.053
H	13.80		14.40	0.543		0.567
h		0.50			0.002	
L	1.20		1.80	0.047		0.071
q		1.70			0.067	
$\alpha$	0°		8°			

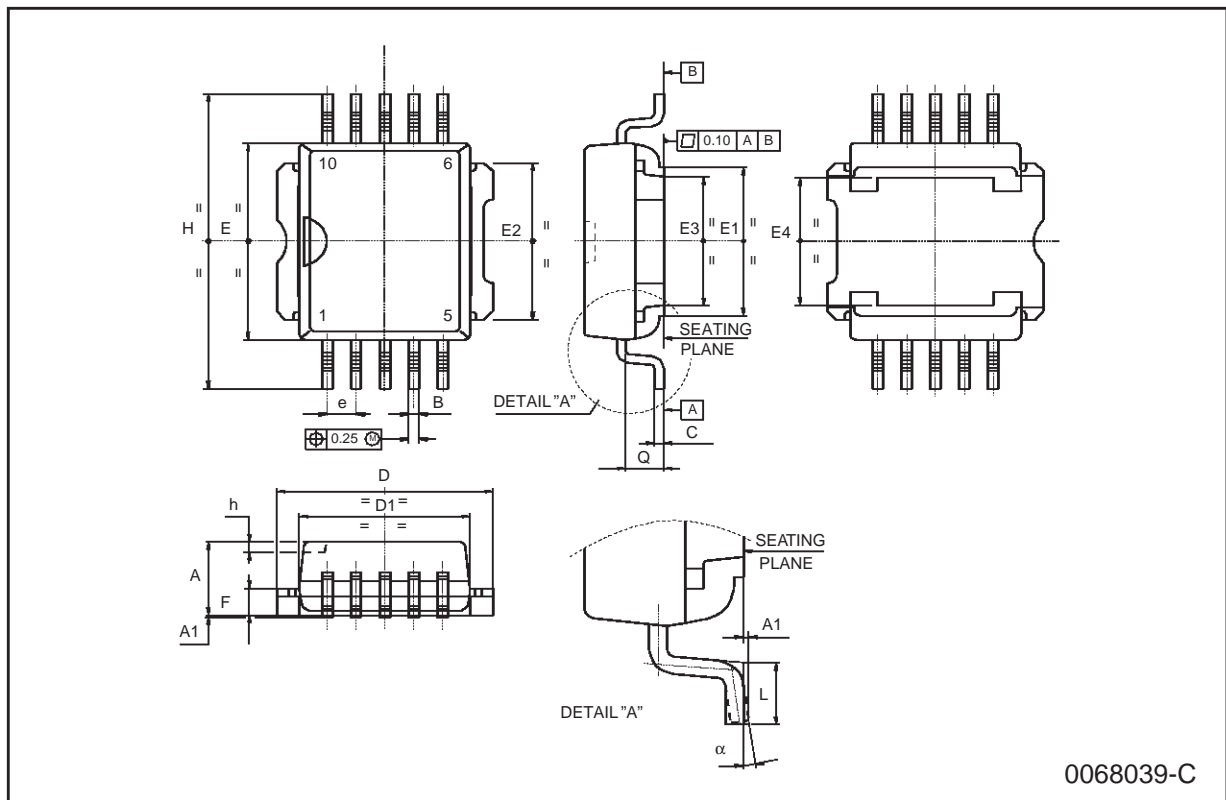



Information furnished is believed to be accurate and reliable. However, STMicroelectronics assumes no responsibility for the consequences of use of such information nor for any infringement of patents or other rights of third parties which may result from its use. No license is granted by implication or otherwise under any patent or patent rights of STMicroelectronics. Specification mentioned in this publication are subject to change without notice. This publication supersedes and replaces all information previously supplied. STMicroelectronics products are not authorized for use as critical components in life support devices or systems without express written approval of STMicroelectronics.

The ST logo is a trademark of STMicroelectronics

© 1998 STMicroelectronics – Printed in Italy – All Rights Reserved  
STMicroelectronics GROUP OF COMPANIES

Australia - Brazil - Canada - China - France - Germany - Italy - Japan - Korea - Malaysia - Malta - Mexico - Morocco - The Netherlands -  
Singapore - Spain - Sweden - Switzerland - Taiwan - Thailand - United Kingdom - U.S.A.