



74LVQ4066

QUAD BILATERAL SWITCH

- HIGH SPEED:
 $t_{PD} = 0.4 \text{ ns}$ (TYP.) at $V_{CC} = 3.3\text{V}$
 $t_{PD} = 0.1 \text{ ns}$ (TYP.) at $V_{CC} = 5\text{V}$
- LOW POWER DISSIPATION:
 $I_{CC} = 2 \mu\text{A}$ (MAX.) at $T_A = 25^\circ\text{C}$
- LOW "ON" RESISTANCE:
 $R_{ON} = 20\Omega$ at $V_{CC} = 3.3\text{V}$, $I_{I/O} \leq 1\text{mA}$
 $R_{ON} = 12\Omega$ at $V_{CC} = 5\text{V}$, $I_{I/O} \leq 1\text{mA}$
- SINE WAVE DISTORTION:
 0.04% at $V_{CC} = 3.3\text{V}$, $f = 1\text{KHz}$
- OPERATING VOLTAGE RANGE:
 $V_{CC(OPER)} = 2\text{V}$ to 5V
- PIN AND FUNCTION COMPATIBLE WITH
 74 SERIES 4066
- IMPROVED LATCH-UP IMMUNITY

DESCRIPTION

The LVQ4066 is a low voltage CMOS QUAD BILATERAL SWITCH fabricated with sub-micron silicon gate and double-layer metal wiring C²MOS

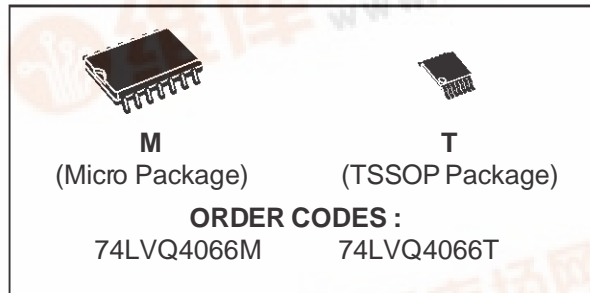

technology. It is ideal for low power and low noise 3.3V applications.

It has an ON-resistance which is greatly reduced in comparison with 74HC4066.

The C input is provided to control the switch; the switch is ON when the C input is held high and OFF when C is held low.

PIN CONNECTION AND IEC LOGIC SYMBOLS

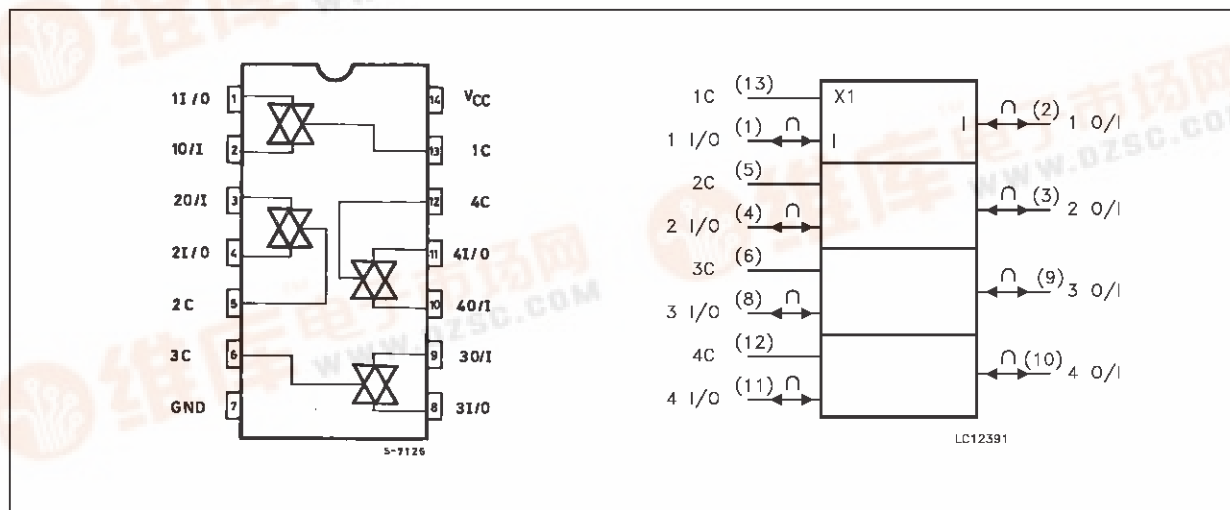

74LVQ4066

LOGIC DIAGRAM

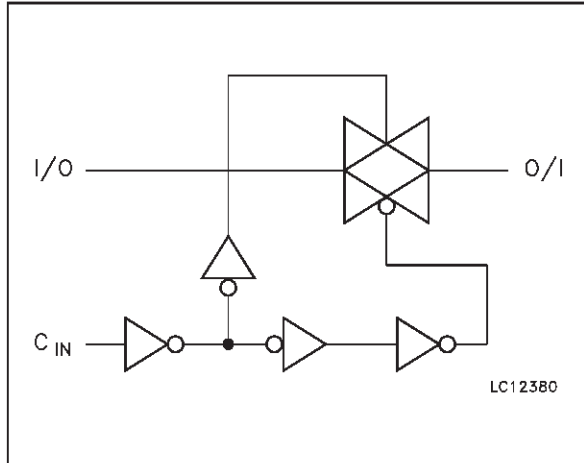

PIN DESCRIPTION

PIN No	SYMBOL	NAME AND FUNCTION
1, 4, 8, 11	1 to 4 I/O	Independent Input/Output
2, 3, 9, 10	1 to 4 O/I	Independent Output/Input
13, 5, 6, 12	1C to 4C	Enable Input (Active HIGH)
7	GND	Ground (0V)
14	V _{CC}	Positive Supply Voltage

TRUTH TABLE

CONTROL	SWITCH FUNCTION
H	ON
L	OFF

ABSOLUTE MAXIMUM RATINGS

Symbol	Parameter	Value	Unit
V _{CC}	Supply Voltage	-0.5 to +7	V
V _I	DC Input Voltage	-0.5 to V _{CC} + 0.5	V
V _O	DC Output Voltage	-0.5 to V _{CC} + 0.5	V
I _{IK}	DC Input Diode Current	± 20	mA
I _{OK}	DC Output Diode Current	± 20	mA
I _O	DC Output Current	± 50	mA
I _{CC} or I _{GND}	DC V _{CC} or Ground Current	± 200	mA
T _{stg}	Storage Temperature	-65 to +150	°C
T _L	Lead Temperature (10 sec)	300	°C

Absolute Maximum Ratings are those values beyond which damage to the device may occur. Functional operation under these condition is not implied.

RECOMMENDED OPERATING CONDITIONS

Symbol	Parameter	Value	Unit
V _{CC}	Supply Voltage (note 1)	2 to 5.5	V
V _I	Input Voltage	0 to V _{CC}	V
V _O	Output Voltage	0 to V _{CC}	V
T _{op}	Operating Temperature:	-40 to +85	°C
dt/dv	Input Rise and Fall Time (note 2)	0 to 10	ns/V

1) Truth Table guaranteed: 1.2V to 5.5V

2) V_{IN} from 30% to 70%V_{CC}

DC SPECIFICATIONS

Symbol	Parameter	Test Conditions		Value					Unit
				T _A = 25 °C			-40 to 85 °C		
				V _{CC} (V)	Min.	Typ.	Max.	Min.	
V _{IH}	High Level Input Voltage	2.7	0.7V _{CC}			0.7V _{CC}		V	
V _{IL}	Low Level Input Voltage	to 5.5						0.3V _{CC}	0.3V _{CC}
R _{ON}	ON Resistance	3.3 ^(**)	V _I = V _{IH} V _{I/O} = V _{CC} to GND I _{I/O} ≤ 1mA	20	30		40	Ω	
		5.0 ^(*)		12	18		24		
		3.3 ^(**)	V _I = V _{IH} V _{I/O} = V _{CC} or GND I _{I/O} ≤ 1mA	10	15		20		
		5.0 ^(*)		9.5	14		19		
ΔR _{ON}	Difference of ON Resistance Between Switches	3.0 to 5.5	V _I = V _{IH} V _{I/O} = V _{CC} to GND I _{I/O} ≤ 1mA	2				Ω	
I _{OFF}	Input/Output Leakage Current (SWITCH OFF)	5.5	V _{OS} = V _{CC} to GND V _{IS} = V _{CC} to GND V _I = V _{IL}			±0.1		±1.0	μA
I _{Iz}	Switch Input Leakage Current (SWITCH ON, OUTPUT OPEN)	5.5	V _{OS} = V _{CC} to GND V _I = V _{IH}			±0.1		±1.0	μA
I _{IN}	Control Input Leakage Current	5.5	V _I = V _{CC} or GND			±0.1		±1.0	μA
I _{CC}	Quiescent Supply Current	5.5	V _I = V _{CC} or GND			2		20	μA

(*) Voltage range is 5V ± 0.5V

(**) Voltage range is 3.3V ± 0.3V

74LVQ4066

AC ELECTRICAL CHARACTERISTICS ($C_L = 50 \text{ pF}$, Input $t_r = t_f = 3 \text{ ns}$)

Symbol	Parameter	Test Condition		Value					Unit
		V_{CC} (V)		$T_A = 25 \text{ }^\circ\text{C}$			$-40 \text{ to } 85 \text{ }^\circ\text{C}$		
				Min.	Typ.	Max.	Min.	Max.	
t_{PD}	Delay Time	3.3 ^(*)			0.4	0.8		1.2	ns
		5.0 ^(**)			0.1	0.2		1.0	
t_{PZL} t_{PZH}	Output Enable Time	3.3 ^(*)	$R_L = 1 \text{ k}\Omega$		2.5	4.0		5.0	ns
		5.0 ^(**)			2.0	4.0		5.0	
t_{PLZ} t_{PHZ}	Output Disable Time	3.3 ^(*)	$R_L = 1 \text{ k}\Omega$		5.0	7.5		9.0	ns
		5.0 ^(**)			5.0	7.5		9.0	
C_{IN}	Input Capacitance				5				pF
$C_{I/O}$	Switch Terminal Capacitance				10				pF
C_{PD}	Power Dissipation Capacitance (note 1)	3.3			2.5				pF
		5.0			3				

1) C_{PD} is defined as the value of the IC's internal equivalent capacitance which is calculated from the operating current consumption without load. (Refer to Test Circuit). Average operating current can be obtained by the following equation. $I_{CC(oper)} = C_{PD} \cdot V_{CC} \cdot f_{IN} + I_{CC}/4$ (switch).

(*) Voltage range is $3.3 \text{ V} \pm 0.3 \text{ V}$

(**) Voltage range is $5 \text{ V} \pm 0.5 \text{ V}$

ANALOG SWITCH CHARACTERISTICS ($GND = 0 \text{ V}$, $T_A = 25^\circ\text{C}$)

Symbol	Parameter	Test Condition			Value	Unit
		V_{CC} (V)	V_{IN} (Vp-p)			
	Sine Wave Distortion (THD)	3.3	2.75	$f_{IN} = 1 \text{ KHz}$ $R_L = 10 \text{ K}\Omega$ $C_L = 50 \text{ pF}$	0.04	%
		5.0 ^(*)	4		0.04	
f_{MAX}	Frequency Response (Switch ON)	3.3	Adjust f_{IN} voltage to Obtain 0dBm at V_{OS} . Increase f_{IN} Frequency until dB Meter reads -3dB $R_L = 50 \Omega$, $C_L = 10 \text{ pF}$		150	MHz
		5.0 ^(*)			180	
	Feedthrough Attenuation (Switch OFF)	3.3	V_{IN} is centered at $V_{CC}/2$. Adjust input for 0dBm $R_L = 600 \Omega$, $C_L = 50 \text{ pF}$, $f_{IN} = 1 \text{ MHz}$ sine wave		-60	dB
		5.0 ^(*)			-60	
	Crosstalk (Control Input to Signal Output)	3.3	$R_L = 600 \Omega$, $C_L = 50 \text{ pF}$, $f_{IN} = 1 \text{ MHz}$ square wave		60	mV
		5.0 ^(*)			60	
	Crosstalk (Between Any Switches)	3.3	$R_L = 600 \Omega$, $C_L = 50 \text{ pF}$, $f_{IN} = 1 \text{ MHz}$ sine wave		-60	dB
		5.0 ^(*)			-60	

(*) Voltage range is $5 \text{ V} \pm 0.5 \text{ V}$

SWITCHING CHARACTERISTICS TEST CIRCUIT

t_{PLZ} , t_{PHZ} , t_{PZL} , t_{PZH} .

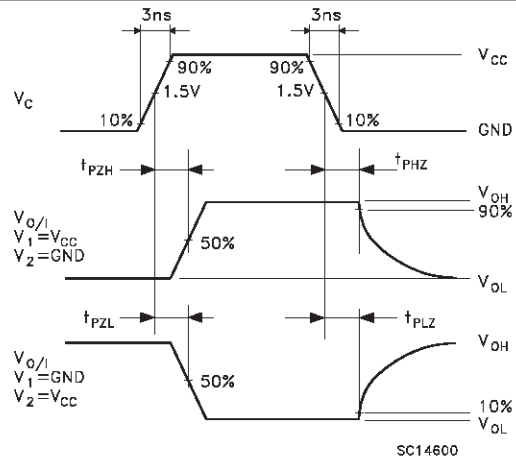
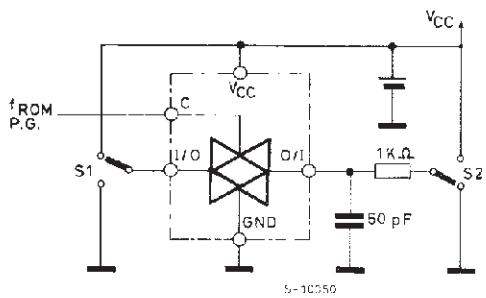

CROSSTALK (control to output)

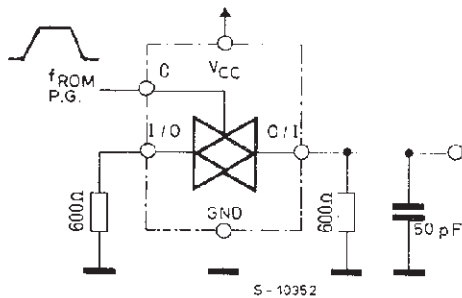

BANDWIDTH AND FEEDTHROUGH ATTENUATION

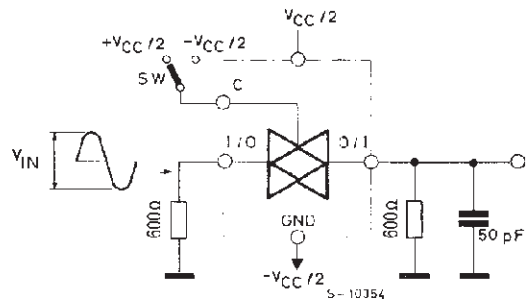

GND (V_{SS})

C_{I-O} $C_{I/O}$

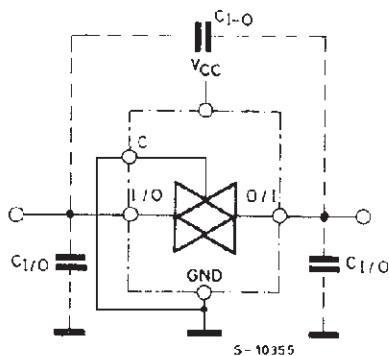

GND (V_{SS})

MAXIMUM CONTROL FREQUENCY

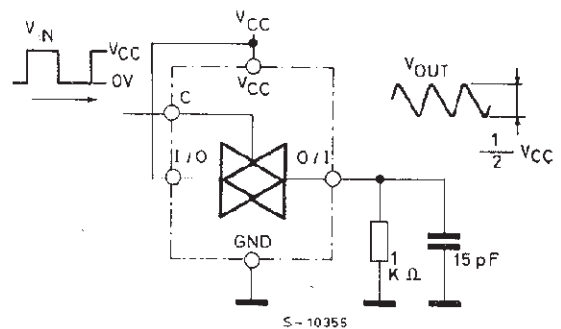

CHANNEL RESISTANCE (R_{ON})

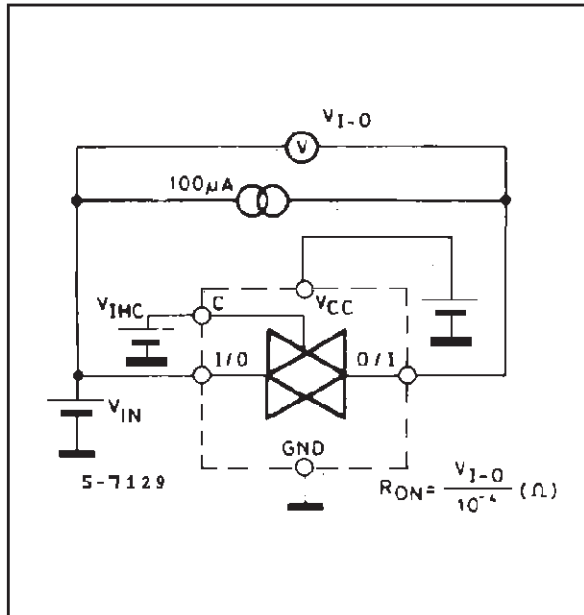

I_{CC} (Opr.)

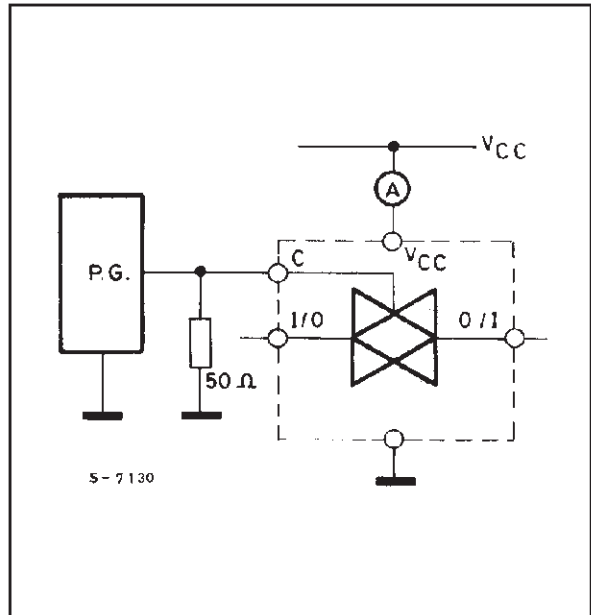

SO-14 MECHANICAL DATA

DIM.	mm			inch		
	MIN.	TYP.	MAX.	MIN.	TYP.	MAX.
A			1.75			0.068
a1	0.1		0.2	0.003		0.007
a2			1.65			0.064
b	0.35		0.46	0.013		0.018
b1	0.19		0.25	0.007		0.010
C		0.5			0.019	
c1	45 (typ.)					
D	8.55		8.75	0.336		0.344
E	5.8		6.2	0.228		0.244
e		1.27			0.050	
e3		7.62			0.300	
F	3.8		4.0	0.149		0.157
G	4.6		5.3	0.181		0.208
L	0.5		1.27	0.019		0.050
M			0.68			0.026
S	8 (max.)					

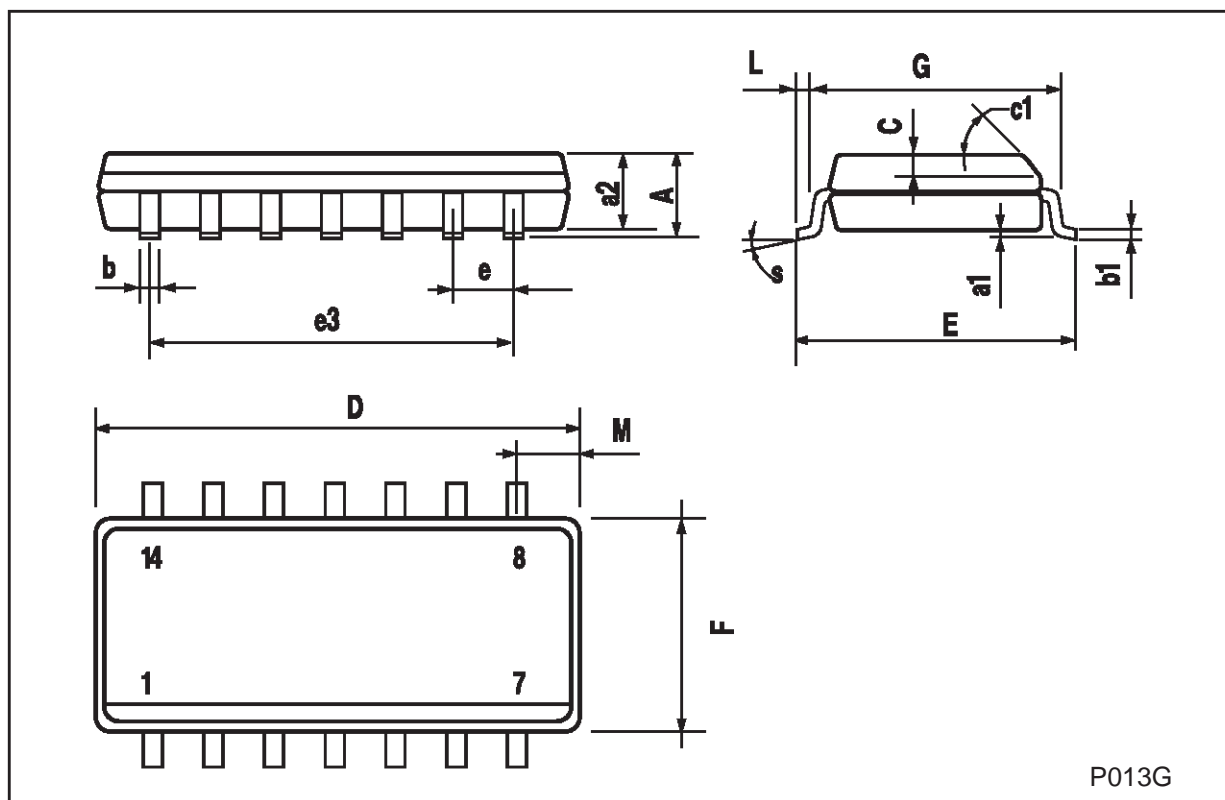

P013G

TSSOP14 MECHANICAL DATA

DIM.	mm			inch		
	MIN.	TYP.	MAX.	MIN.	TYP.	MAX.
A			1.1			0.433
A1	0.05	0.10	0.15	0.002	0.004	0.006
A2	0.85	0.9	0.95	0.335	0.354	0.374
b	0.19		0.30	0.0075		0.0118
c	0.09		0.20	0.0035		0.0079
D	4.9	5	5.1	0.193	0.197	0.201
E	6.25	6.4	6.5	0.246	0.252	0.256
E1	4.3	4.4	4.48	0.169	0.173	0.176
e		0.65 BSC			0.0256 BSC	
K	0°	4°	8°	0°	4°	8°
L	0.50	0.60	0.70	0.020	0.024	0.028

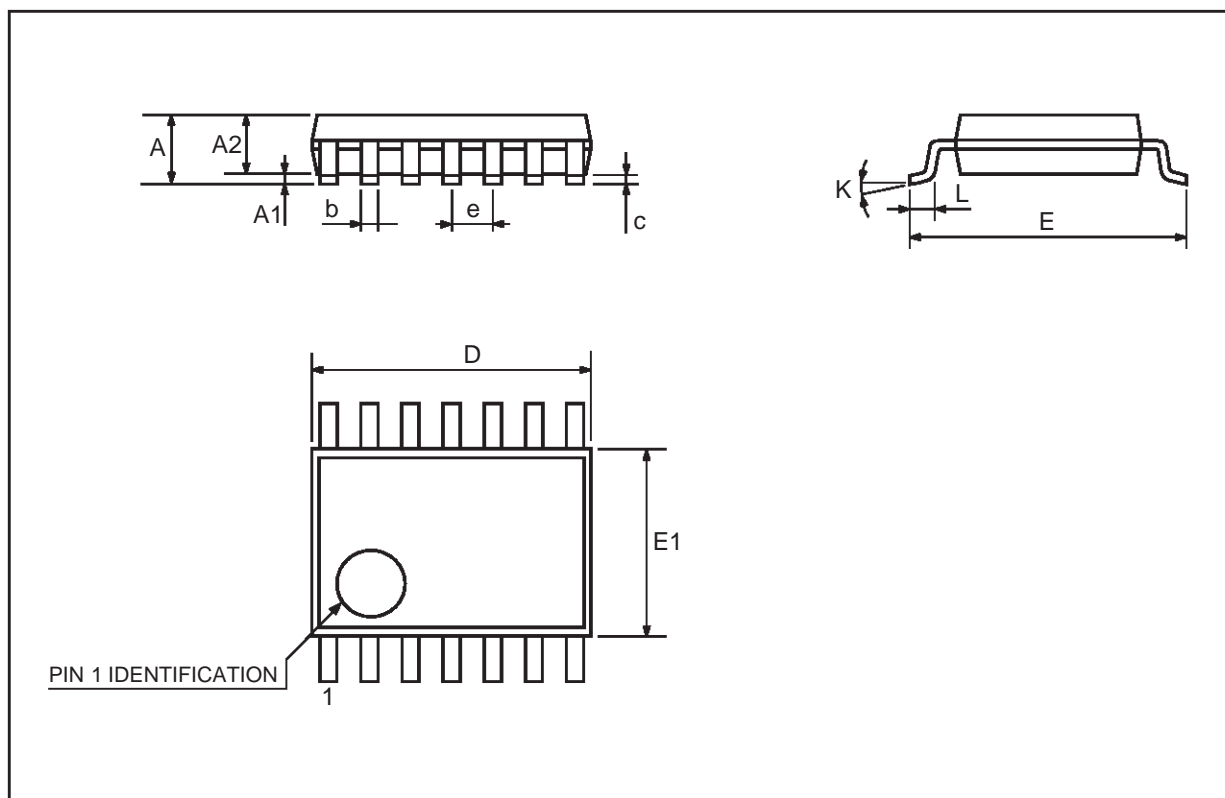

Information furnished is believed to be accurate and reliable. However, STMicroelectronics assumes no responsibility for the consequences of use of such information nor for any infringement of patents or other rights of third parties which may result from its use. No license is granted by implication or otherwise under any patent or patent rights of STMicroelectronics. Specification mentioned in this publication are subject to change without notice. This publication supersedes and replaces all information previously supplied. STMicroelectronics products are not authorized for use as critical components in life support devices or systems without express written approval of STMicroelectronics.

The ST logo is a registered trademark of STMicroelectronics

© 1999 STMicroelectronics – Printed in Italy – All Rights Reserved

STMicroelectronics GROUP OF COMPANIES

Australia - Brazil - China - Finland - France - Germany - Hong Kong - India - Italy - Japan - Malaysia - Malta - Morocco
Singapore - Spain - Sweden - Switzerland - United Kingdom - U.S.A.

<http://www.st.com>