



Preliminary Data Sheet VSC7132

Link Replicator for Fibre Channel, Gigabit Ethernet and HDTV

Features

- Replicates Fibre Channel, Gigabit Ethernet and HDTV Links
- T11 Fibre Channel Compliant at 1.0625Gb/s
- IEEE802.3z Gigabit Ethernet Compliant at 1.25Gb/s
- SMPTE-292M Compliant at 1.485Gb/s
- No External Components Required
- 0.4W Maximum Power Dissipation
- 3.3V Power Supply
- 28-Pin, 4.4 x 9.7mm TSSOP Package

General Description

The VSC7132 is a high performance serial Link Replicator for applications in Fibre Channel (1.0625Gb/s), Gigabit Ethernet (1.25Gb/s) and HDTV (1.485Gb/s). A serializer/deserializer, such as the VSC7123, would normally be connected to the IN+/- and OUT+/- ports in order to provide duplicate links on the IN0/OUT0 and IN1/OUT1 ports. A popular application is for Line Cards using serial links from a SerDes (VSC7123) or Serial Backplane IC (VSC7211) where the VSC7132 provides redundant, hot-swappable links to redundant Switch Fabric Cards. Another common application is in Host Adapters which require an internal and an external connector where the VSC7132 steers serial data between the SerDes (VSC7123) and the two connectors.

IN is sent to both OUT0 and OUT1 whose buffers are enabled when OE0 and OE1 are HIGH. OUT1 can select between IN and IN0. OUT can select between IN0 and IN1.

In Link Replicator applications, such as the Line Card to Switch Card links, IN is transmitted to both OUT0 and OUT1, which either IN0 or IN1 is selected at OUT. In Host Adaptor applications, IN goes to OUT0 (an internal connector) which returns data on IN0. IN0 is looped to OUT1 (an external connector) which returns data on IN1 and then back to the SerDes on OUT.

VSC7132 Block Diagram

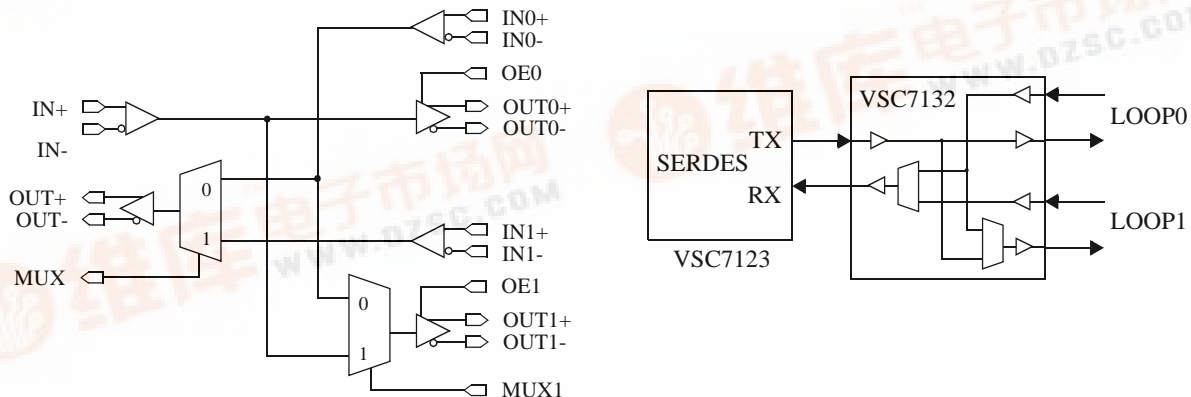



Figure 1: Timing Waveforms

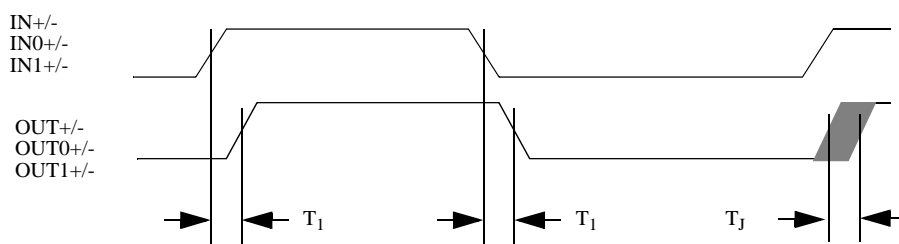

Table 1: AC Characteristics (Over recommended operating conditions)

Parameters	Description	Min	Typ	Max	Units	Conditions
F	Operating frequency range	1.0		1.5	Gb/s	
T_1	Flow-through propagation delay			7.0	ns	Delay from any input to any output.
T_R, T_F	Serial data rise and fall time	—		300	ps	20% to 80%, tested on a sample basis
T_J	Deterministic jitter added to serial input	—		30	ps p-p	1.0 - 1.25 Gb/s. Measured on K28.5+, K28.5- pattern
		—		40	ps p-p	1.25 - 1.5 Gb/s. Measured on K28.5+, K28.5- pattern

Table 2: DC Characteristics (Over recommended operating conditions)

Parameters	Description	Min	Typ	Max	Units	Conditions
$V_{IH(TTL)}$	Input HIGH voltage	2.0	—	5.5	V	
$V_{IL(TTL)}$	Input LOW voltage	0	—	0.8	V	
$I_{IH(TTL)}$	Input HIGH current	—	—	100	mA	$V_{IN} = 2.4$ V
$I_{IL(TTL)}$	Input LOW current	—	—	-100	mA	$V_{IN} = 0.5$ V
V_{DD}	Supply voltage	3.14	—	3.47	V	$V_{DD} = 3.30V \pm 5\%$
I_{DD}	Supply current	—	—	150	mA	Outputs open, $V_{DD} = V_{DD}$ max
P_D	Power dissipation		275	400	mW	Outputs open, $V_{DD} = V_{DD}$ max
$DV_{IN}^{(1)}$	Receiver differential peak-to-peak Input Sensitivity, IN, IN0, IN1	300		2600	mVp-p	AC-Coupled. Internally biased at $V_{DD}/2$
$DV_{OUT50}^{(1)}$	Output differential peak-to-peak voltage swing, OUT, OUT0, OUT1	1000	—	2200	mVp-p	50Ω to $V_{DD} - 2.0$ V
$DV_{OUT75}^{(1)}$	Output differential peak-to-peak voltage swing, OUT, OUT0, OUT1	1200		2200	mVp-p	75Ω to $V_{DD} - 2.0$ V

NOTE: (1) Refer to Application Note, AN-37, for differential measurement techniques.



Preliminary Data Sheet
VSC7132

Link Replicator for Fibre
Channel, Gigabit Ethernet and HDTV

Absolute Maximum Ratings (1)

TTL Power Supply Voltage (V_{DD})	0.5V to +4V
PECL DC Input Voltage (V_{INP})	-0.5V to $V_{DD} + 0.5V$
TTL DC Input Voltage (V_{INT})	-0.5V to +5.5V
DC Voltage Applied to Outputs for High Output State ($V_{IN\ TTL}$)	-0.5V to $V_{DD} + 0.5V$
PECL Output Current, (I_{OUT}) (DC, Output High)	-50mA
Case Temperature Under Bias (T_C)	-55°C to +125°C
Storage Temperature (T_{STG})	-65°C to +150°C

Recommended Operating Conditions(2)

Power Supply Voltage (V_{DD})	+3.14V to +3.47V
Ambient Operating Temperature Range (T)	0°C to +70°C

NOTES: (1) CAUTION: Stresses listed under “Absolute Maximum Ratings” may be applied to devices one at a time without causing permanent damage. Functionality at or above the values listed is not implied. Exposure to these values for extended periods may affect device reliability.

(2) Vitesse guarantees the functional and parametric operation of the part under “Recommended Operating Conditions” except where specifically noted in the AC and DC Parametric Tables

Figure 2: Application Example: VSC7123 and VSC7132 Interconnect

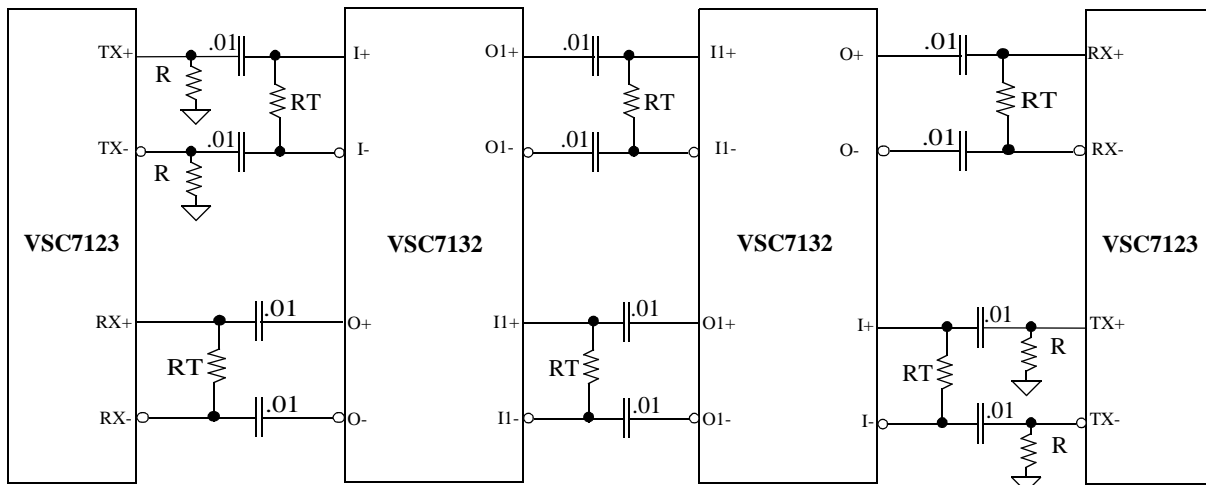

“R” is 180Ω for 100Ω differential traces or 267Ω for 150Ω differential traces.
“RT” matches the differential impedance of the link.



Package Pin Descriptions

Figure 3: Pin Diagram

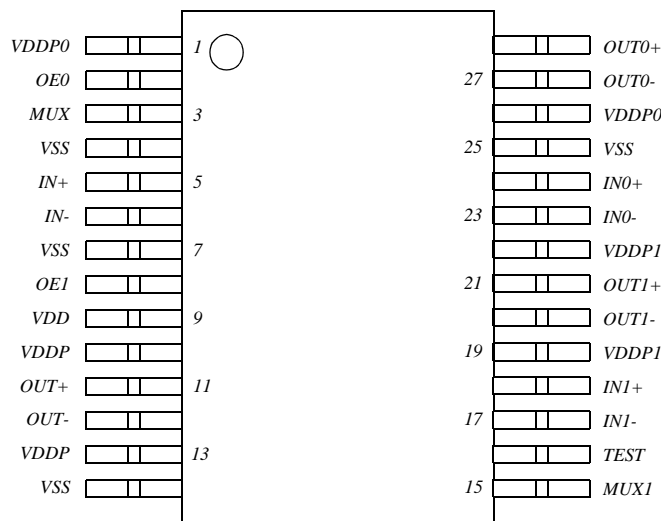

Table 3: Pin Identification

Pin #	Name	Description
5, 6 24, 23 18, 17	IN+, IN- IN0+, IN0- IN1+, IN1-	INPUT - Differential (Biased to $V_{DD}/2$): High-speed Serial Inputs.
11, 12 28, 27 21, 20	OUT+, OUT- OUT0+, OUT0- OUT1+, OUT1-	OUTPUT - Differential: High-speed Serial Outputs.
2 8	OE0 OE1	INPUT - TTL: OE0/OE1 enables OUT0/OUT1 when HIGH. When LOW, OUTx is powered down and both OUTx+ and OUTx- float HIGH.
3	MUX	INPUT - TTL: Determines source of OUT. Selects either IN0 (LOW) or IN1 (HIGH).
15	MUX1	INPUT - TTL: Determines source of OUT1. Selects either IN (HIGH) or IN0 (LOW).
16	TEST	INPUT - TTL: LOW for normal operation. HIGH for factory test.
9	VDD	Digital Logic Power Supply: 3.3V supply for digital logic.
10, 13 1, 26 19, 22	VDDP VDDP0 VDDP1	High-speed Output Power Supply: 3.3V supply for PECL drivers. VDDP0 is for OUT0, VDDP is for OUT, and VDDP1 is for OUT1.
4, 7 14, 25	VSS	Ground.



Preliminary Data Sheet
VSC7132

Link Replicator for Fibre
Channel, Gigabit Ethernet and HDTV

Package Information

28-Pin, 4.4 x 9.7 mm TSSOP

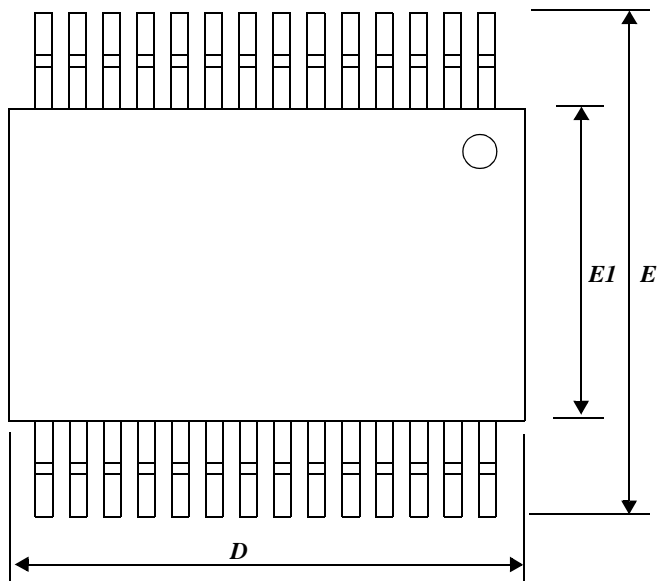

Item	mm	Tol.
E1	4.40	± 0.10
E	6.40	BSC
D	9.70	BSC
A	1.20	MAX
A1	0.10	± 0.05
A2	1.00	$+0.05 / -0.20$
e	0.65	BSC
b	0.25	$+0.05 / -0.06$
c	0.15	$+0.05 / -0.06$
L	0.60	± 0.15

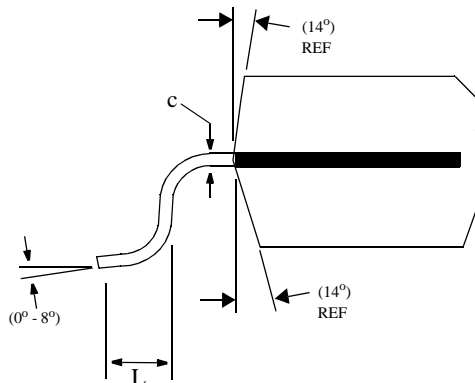
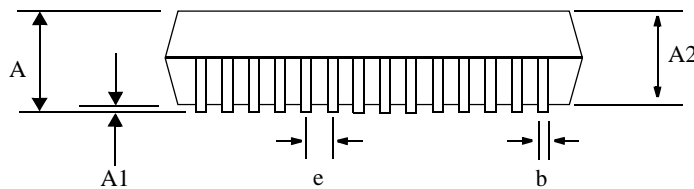

NOTES:
Drawing not to scale.
All units in mm unless otherwise noted.

Package Thermal Characteristics

The VSC7132 is packaged into a TSSOP package with 28 leads. The package construction is as shown in Figure 4. This package allows the VSC7132 to operate with ambient temperatures up to 70°C in still air.

Figure 4: Package Cross Section

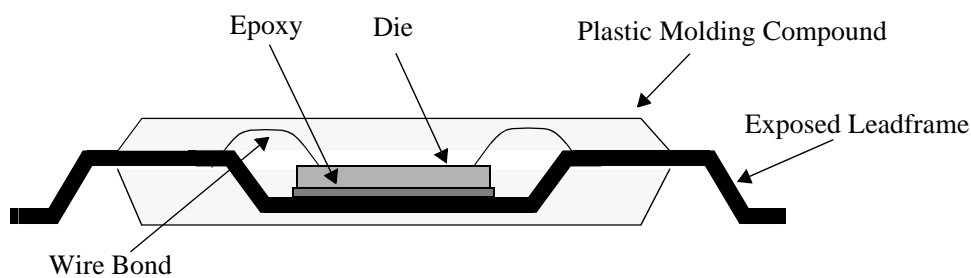

Table 4: Thermal Resistance

Symbol	Description	Value	Units
θ_{ca-0}	Thermal resistance from case-to-ambient, still air	45	°C/W
θ_{ca-100}	Thermal resistance from case-to-ambient, 100 LFPM air	45	°C/W
θ_{ca-200}	Thermal resistance from case-to-ambient, 200 LFPM air	41	°C/W
θ_{ca-400}	Thermal resistance from case-to-ambient, 400 LFPM air	37	°C/W
θ_{ca-600}	Thermal resistance from case-to-ambient, 600 LFPM air	33	°C/W

Moisture Sensitivity Level

This device is rated with a moisture sensitivity level 3 rating. Refer to Application Note AN-20 for appropriate handling procedures.



Preliminary Data Sheet VSC7132

Link Replicator for Fibre
Channel, Gigabit Ethernet and HDTV

Ordering Information

The order number for this product is formed by a combination of the device number and package type.

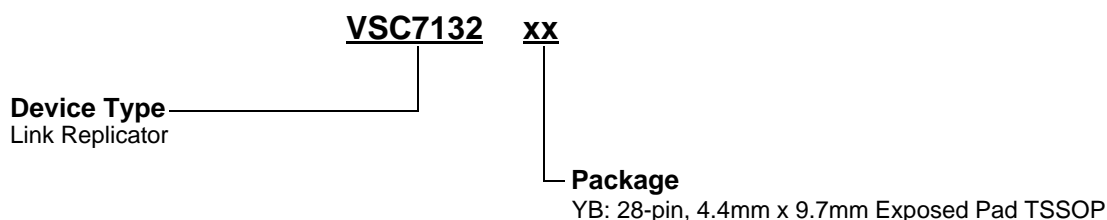

Marking Information

The package is marked with three lines of text as shown (not to scale).

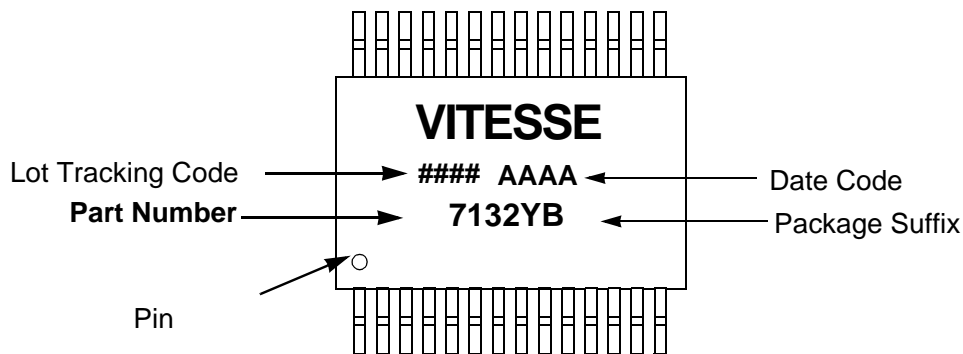

Notice

This document contains information about a new product during its fabrication or early sampling phase of development. The information in this document is based on design targets, simulation results or early prototype test results. Characteristic data and other specifications are subject to change without notice. Therefore, the reader is cautioned to confirm that this datasheet is current prior to design or order placement.

Warning

Vitesse Semiconductor Corporation's products are not intended for use in life support appliances, devices or systems. Use of a Vitesse product in such applications without written consent is prohibited.



VITESSE
SEMICONDUCTOR CORPORATION

*Link Replicator for Fibre
Channel, Gigabit Ethernet and HDTV*

**Preliminary Datasheet
VSC7132**

