



# VSP2080

## *SpeedPlus*™ CCD SIGNAL FRONT-END PROCESSOR FOR DIGITAL CAMERAS

### FEATURES

- **CCD SIGNAL PROCESSING**  
 Correlated Double Sampling  
 Black Level Clamping  
 0 to +34dB Gain Range  
 55dB SNR Referred to Full Scale
- **SELECTABLE LOGIC-INPUT POLARITY**  
 Positive Active or Negative Active
- **PORTABLE OPERATION**  
 Low Voltage: 2.7V to 3.6V  
 Low Power: 144mW at 3.0V  
 Power-Down Mode: 10mW

### DESCRIPTION

The VSP2080 is a complete front-end processing IC for digital cameras. The VSP2080 provides signal conditioning for the output of a CCD array. The VSP2080 provides correlated double sampling to extract the video information from the pixels, 0dB to +34dB gain range with analog control for varying illumination conditions, and black level clamping for an accurate black reference. The stable gain control is linear in dB. Additionally, the black level quickly recovers after screen changes. The MODE pin allows the selection of logic-input polarity. The VSP2080 is available in a 20-lead TSSOP package.

### APPLICATIONS

- VIDEO CAMERAS
- DIGITAL STILL CAMERAS
- PC CAMERAS
- SECURITY CAMERAS

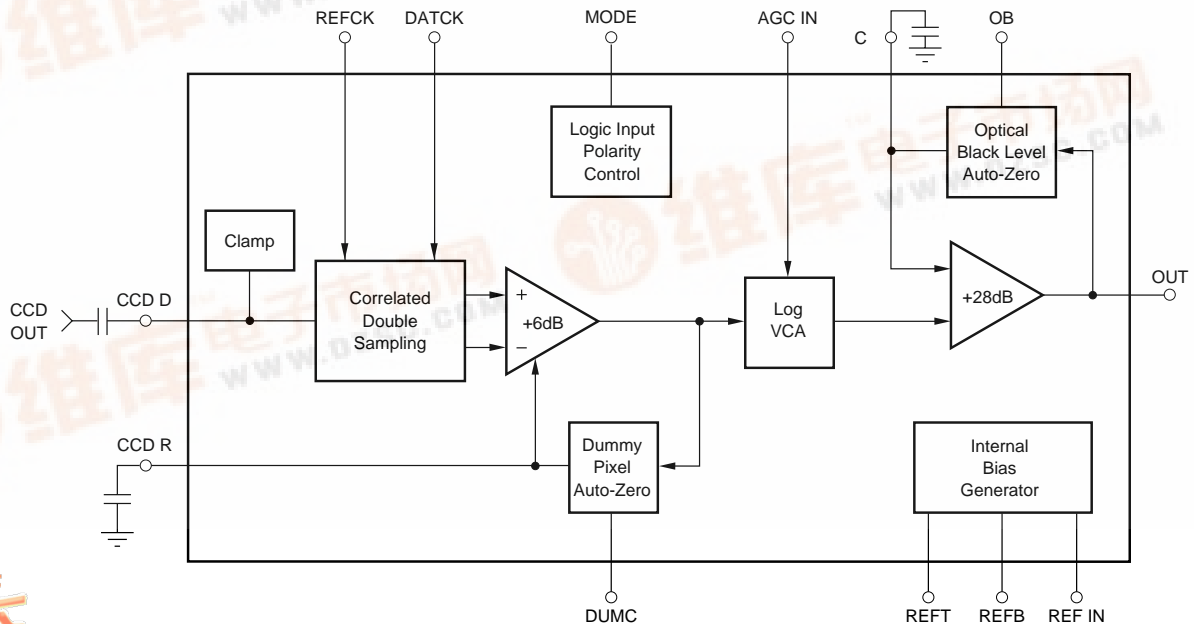

# SPECIFICATIONS

At  $T_A = +25^\circ\text{C}$ , and  $V_{DDA} = +3.0\text{V}$ , unless otherwise specified.

PARAMETER	CONDITIONS	VSP2080T			UNITS
		MIN	TYP	MAX	
<b>DIGITAL INPUT</b>					
Logic Family			CMOS		
Logic Levels	Logic HI	2.5		$+V_{DDA}$	V
	Logic LO	0		+0.4	V
Logic Currents	Logic HI, $V_{IN} = +V_{DDA}$			10	$\mu\text{A}$
	Logic LO, $V_{IN} = 0\text{V}$			10	$\mu\text{A}$
<b>ANALOG OUTPUT</b>					
Output Voltage		1.0		2.0	V
Output Black Level		1.010	1.030	1.045	x REF IN
Reference Input (REF IN)		0.90	1.0	1.1	V
<b>TRANSFER CHARACTERISTICS</b>					
Signal-to-Noise Ratio <sup>(1)</sup>	Grounded Input Cap, Gain Min		55		dB
Black Clamp Level			31		mV
<b>CDS</b>					
Data Settling Time to $\pm 0.1\%$ for FS Change with $R_S = 40$	From Leading Edge of DATCK		11		ns
Input Capacitance	DATCK LOW		20		pF
Input Time Constant			300		ps
Full-Scale Input Voltage	After AC-Coupling Cap	600			mV
<b>INPUT CLAMP</b>					
Clamp-On Resistance			3.3		k $\Omega$
Clamp Level			1		V
<b>GAIN CONTROL CHARACTERISTICS</b>					
Linear Gain Control Voltage Range		0.7		2.3	V
Gain at Max Control Voltage			34		dB
Gain Control Linearity			$\pm 1.0$		dB
Gain Control Settling Time			10		$\mu\text{s}$
Transfer Function	Linear Range		20.6		dB/V
<b>POWER SUPPLY</b>					
Rated Voltage		+2.7	+3.0	+3.6	V
Current, Quiescent			48		mA
Power Dissipation			144		mW
Power-Down Mode			10		mW
<b>TEMPERATURE RANGE</b>					
Specified Range	Ambient	-25		+85	$^\circ\text{C}$
Thermal Resistance, $\theta_{JA}$ 20-Lead TSSOP			130		$^\circ\text{C}/\text{W}$

NOTE: (1) SNR =  $20\log$  (full-scale voltage/rms noise).

The information provided herein is believed to be reliable; however, BURR-BROWN assumes no responsibility for inaccuracies or omissions. BURR-BROWN assumes no responsibility for the use of this information, and all use of such information shall be entirely at the user's own risk. Prices and specifications are subject to change without notice. No patent rights or licenses to any of the circuits described herein are implied or granted to any third party. BURR-BROWN does not authorize or warrant any BURR-BROWN product for use in life support devices and/or systems.

## PIN CONFIGURATION

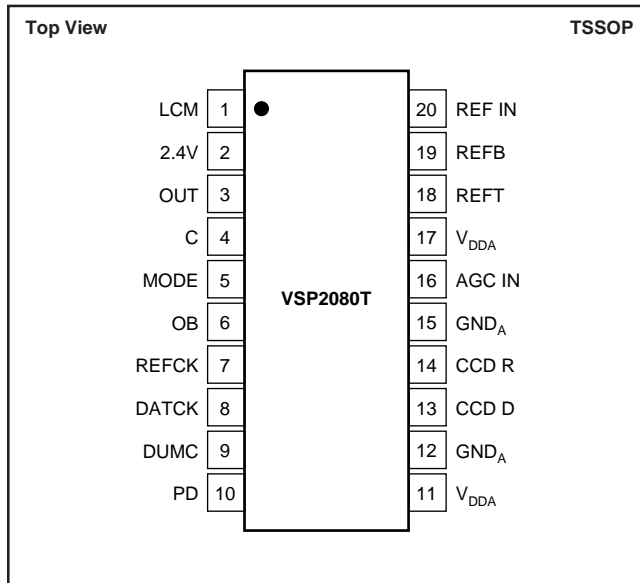

## ABSOLUTE MAXIMUM RATINGS

+V <sub>S</sub> .....	+6V
Analog Input .....	-0.3V to (+V <sub>DDA</sub> +0.3V)
Logic Input .....	-0.3V to (+V <sub>DDA</sub> +0.3V)
Case Temperature .....	+100°C
Junction Temperature .....	+150°C
Storage Temperature .....	+150°C

## PIN DESCRIPTIONS

PIN	DESIGNATOR	TYPE	DESCRIPTION
1	LCM	Bypass	Attenuator Common-Mode Bypass, Bypass to GND with 0.1μF capacitor
2	2.4V	Bypass	Attenuator Ladder Bypass, Bypass to GND with 0.1μF capacitor
3	OUT	Analog Output	Analog Output
4	C	Capacitor	Capacitor for Optical Black Auto-Zero Loop
5	MODE	Logic Input	Mode Control for Logic Input: LO = Positive Pulse Active HI = Negative Pulse Active
6	OB	Logic Input	Optical Black Clamp Pulse
7	REFCK	Logic Input	Sampling Pulse for Reset
8	DATCK	Logic Input	Sampling Pulse for Data
9	DUMC	Logic Input	Dummy Pixel Clamp Pulse
10	PD	Logic Input	Power-Down Control: LO = Normal Operation HI = Reduced Power
11	V <sub>DDA</sub>	Power Supply	Positive Power Supply
12	GND <sub>A</sub>	Ground	Analog Ground
13	CCD D	Analog Input	CCD Signal Input
14	CCD R	Capacitor	Capacitor for Dummy Feedback Loop
15	GND <sub>A</sub>	Ground	Analog Ground
16	AGC IN	Analog Input	Sets Gain of Gain Control Amp.
17	V <sub>DDA</sub>	Power Supply	Positive Power Supply
18	REFT	Bypass	Bypass for Internal Top Reference
19	REFB	Bypass	Bypass for Internal Bottom Reference
20	REF IN	Analog Input	External Reference Input (1.0V)

## PACKAGE/ORDERING INFORMATION

PRODUCT	PACKAGE	PACKAGE DRAWING NUMBER <sup>(1)</sup>	SPECIFIED TEMPERATURE RANGE	PACKAGE MARKING	ORDERING NUMBER <sup>(2)</sup>	TRANSPORT MEDIA
VSP2080T "	20-Lead TSSOP "	353 "	-25°C to +85°C "	VSP2080T "	VSP2080T VSP2080T/2K	250-Piece Tray Tape and Reel

NOTES: (1) For detailed drawing and dimension table, please see end of data sheet, or Appendix C of Burr-Brown IC Data Book. (2) Models with a slash (/) are available only in Tape and Reel in the quantities indicated (e.g., /2K indicates 2000 devices per reel). Ordering 2000 pieces of "VSP2080T/2K" will get a single 2000-piece Tape and Reel.

## ELECTROSTATIC DISCHARGE SENSITIVITY

This integrated circuit can be damaged by ESD. Burr-Brown recommends that all integrated circuits be handled with appropriate precautions. Failure to observe proper handling and installation procedures can cause damage.

ESD damage can range from subtle performance degradation to complete device failure. Precision integrated circuits may be more susceptible to damage because very small parametric changes could cause the device not to meet its published specifications.

## TIMING DIAGRAM

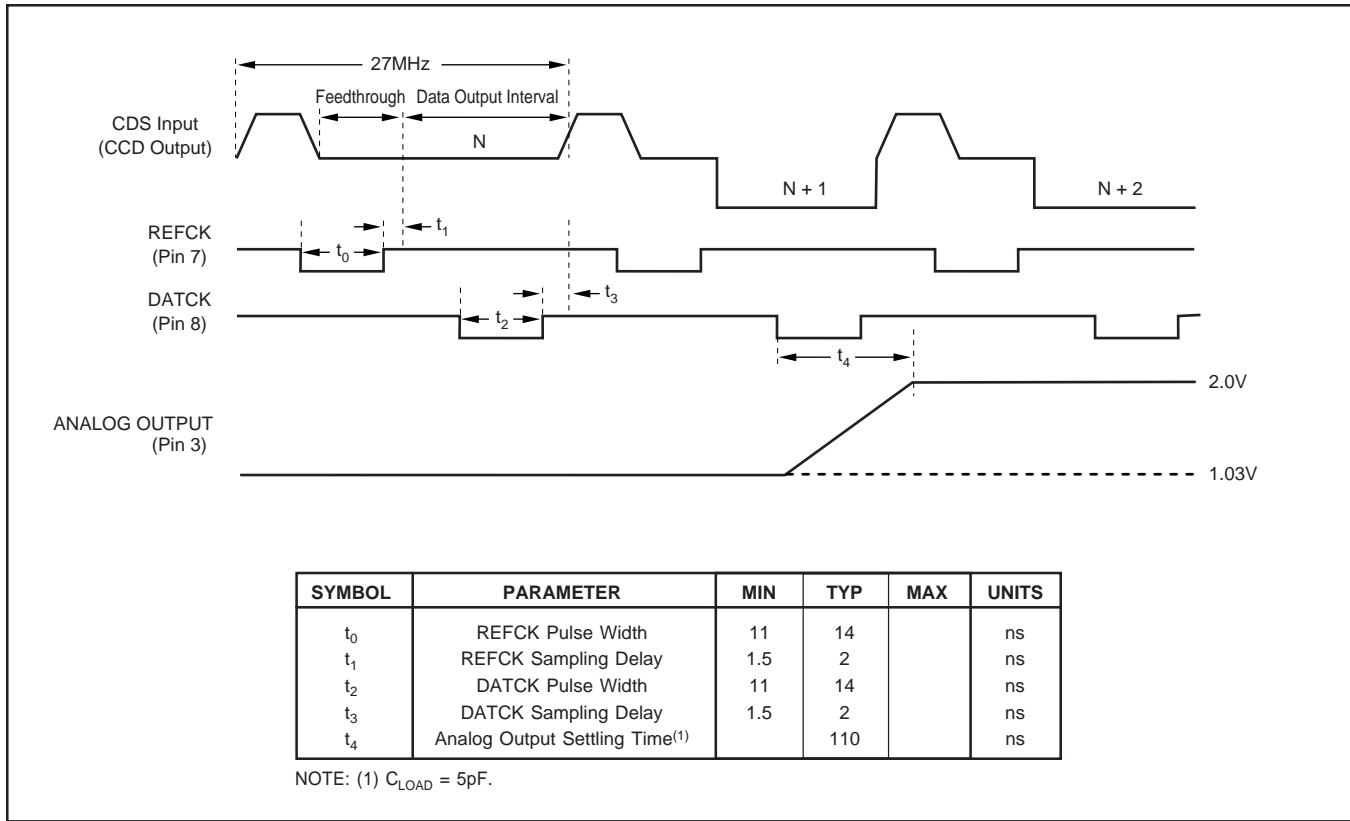

## TYPICAL PERFORMANCE CURVES

At  $T_A = +25^\circ C$ ,  $V_{DD} = +3.0V$ , and conversion rate = 18MHz, unless otherwise specified.

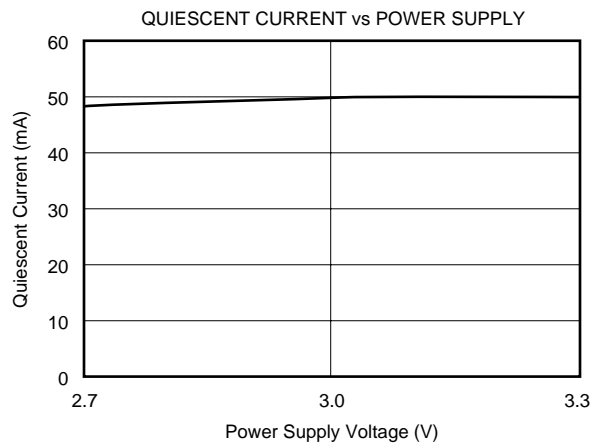
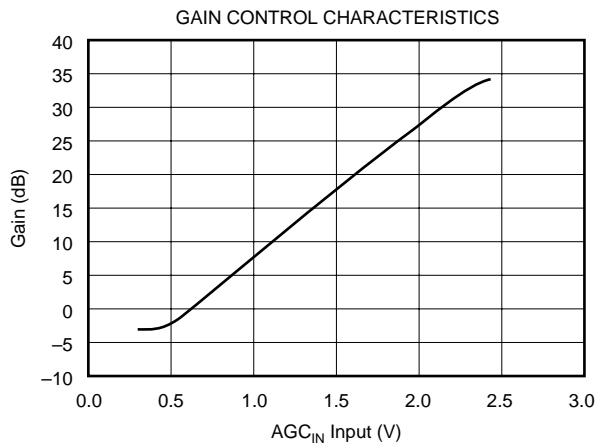

# THEORY OF OPERATION

The VSP2080 contains all of the key features associated with the processing of analog signals in a CCD video camera or digital still camera. Figure 1 shows a simplified block diagram of the VSP2080. The output from the CCD array is first clamped to an internal reference of +1V. This sets the proper signal range for the input of the Correlated Double Sampler (CDS). The CDS operates at a gain of 2 and provides a differential output. Its output drives a voltage-controlled attenuator with a logarithmic control characteristic. An output amplifier drives this signal to external circuitry and sets the proper black level for the ADS900 A/D converter.

# CORRELATED DOUBLE SAMPLER (CDS)

The CDS removes low frequency noise from the output of the image sensor. Refer to Figure 2 which shows a block diagram of the CDS. The output from the CCD array is sampled during the reference interval as well as during the data interval. Noise that is present at the input and is of a period greater than the pixel interval will be eliminated by subtraction.

The VSP2080 employs a three track-and-hold correlated double sampler architecture. Track/Hold 2 samples the CCD noise during the reference interval as driven by the REFCK signal. Track/Hold 3 resamples this level at the same time that Track/Hold 1 samples the video information as driven by the DATCK signal. This is done to remove large transients from Track/Hold 2 that result from a portion of the reset transient being present during the acquisition time of this track-and-hold. The output of Track/Hold 2 is buffered by a voltage follower.

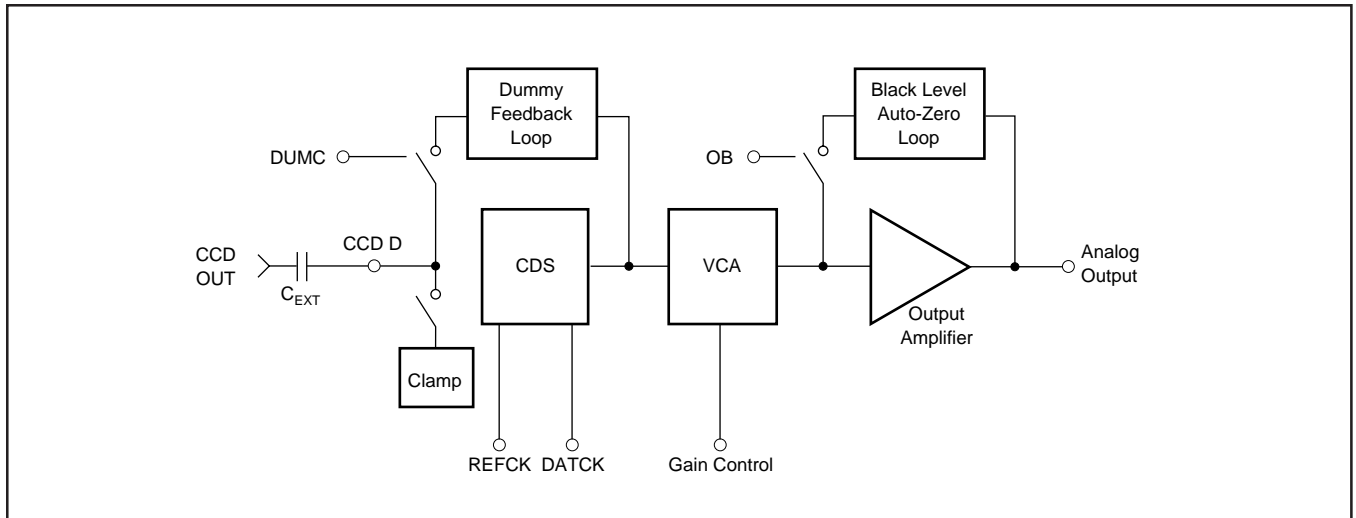

FIGURE 1. Simplified Block Diagram of VSP2080.

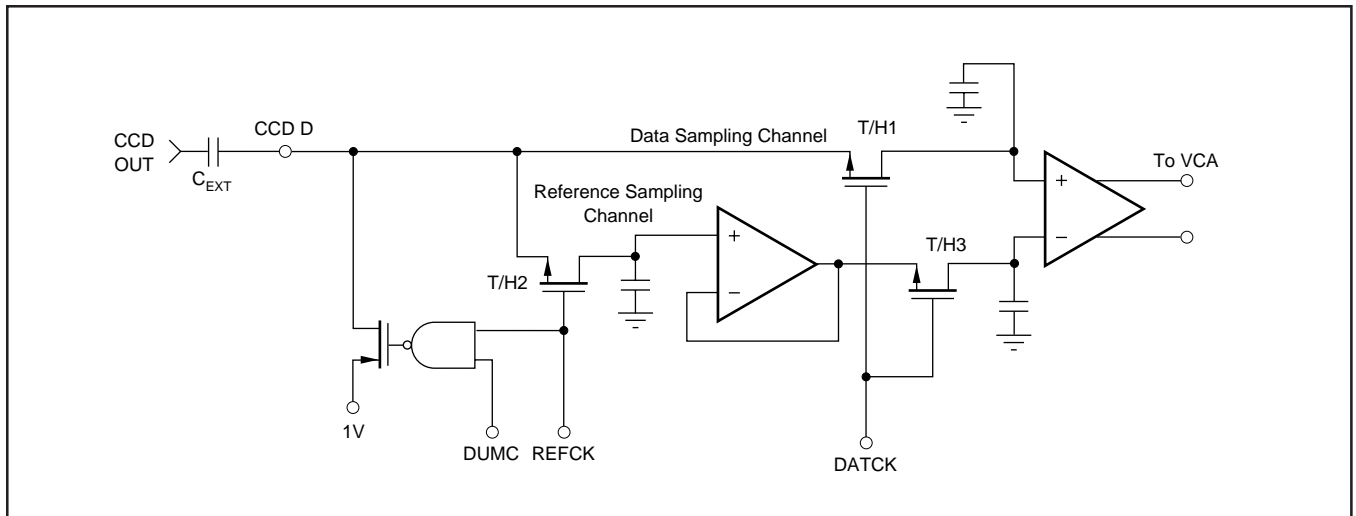

FIGURE 2. Simplified Block Diagram of Correlated Double Sampler.

## DIFFERENCE AMPLIFIER

The correlated double sampler function is completed when the output of the data and reference channel are sent to the difference amplifier where the signals are subtracted. In addition to providing the difference function, the difference amplifier amplifies the signal by a factor of 2 which helps to improve the overall signal-to-noise ratio. The difference amplifier also generates a differential signal to drive the voltage-controlled attenuator.

## INPUT CLAMP

The output from the CCD array is capacitively coupled to the VSP2080. To prevent shifts in the DC level from taking place due to varying input duty cycles, the input capacitor is clamped during the dummy pixel interval by the REFCK signal. A P-channel transistor is used for this input clamp switch to be able to allow a 2V negative change at the input that would bring the signal below ground by 1V. Under typical conditions, the black level at the input to the VSP2080 is at 1V.

## DUMMY PIXEL AUTO-ZERO LOOP

The output from the data and reference channel is processed by the previously mentioned difference amplifier. The differential output from the difference amplifier is sent to both the voltage-controlled logarithmic attenuator and to an error amplifier. The error amplifier amplifies and feeds a signal to the difference amplifier to drive the offset measured at the output of the difference amplifier to zero. A block diagram of this circuit is shown in Figure 3. This error amplifier serves the purpose of reducing the offset of the CDS to avoid a large offset from being amplified by the output amplifier. The effective time constant of this loop is given by:

$$T = \frac{R \cdot C}{A \cdot D}$$

where R is 10kΩ, C is an external capacitor connected to CCD R (pin 14), A is the gain of the error amplifier with a value of 50, and D is the duty cycle of the time that the dummy pixel auto-zero loop is in operation. The duty cycle (D) must

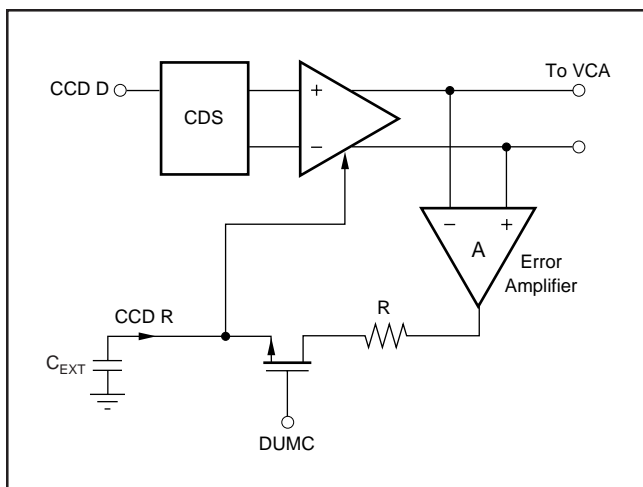

FIGURE 3. Simplified Block Diagram of Dummy Pixel Loop

be considered as the loop operates in a sampled mode. Operation of the dummy auto-zero loop is activated by the DUMC signal that happens once during each horizontal line interval.

## TIMING

The REFCK and DATCK signals are used to operate the CDS as previously explained. The input digital timing signals REFCK, DATCK, DUMC and OB are capable of being driven from either 3V or 5V logic levels.

## VOLTAGE-CONTROLLED ATTENUATOR

To maximize the dynamic range of the VSP2080, a voltage-controlled attenuator is included with a control range from 0dB to -34dB. The gain control has a logarithmic relationship between the control voltage and the attenuation. The attenuator processes a differential signal from the difference amplifier to improve linearity and to reject both power supply and common-mode noise. The output from the attenuator is amplified by 28dB prior to being applied to the A/D. A typical gain control characteristic of the VSP2080 is shown in the typical performance curve, "Gain Control Characteristics".

## BLACK LEVEL AUTO-ZERO LOOP

The black level auto-zero loop amplifies the difference between the output of the output amplifier and a reference signal during the dummy pixel interval. This difference signal is amplified and fed back into the output amplifier to correct the offset. In doing so, the output level of the entire CCD channel can be controlled to be approximately -FS + 31mV under zero signal conditions. The black level auto-zero loop is activated by the OB timing signal. Figure 4 shows a block diagram of the black level auto-zero loop. The loop time constant is given by:

$$T = \frac{C}{G_M \cdot D}$$

where C is the external filter capacitance applied to C (pin 4), G<sub>M</sub> is .001 Siemens (inverse ohm) and D is the duty cycle of the time that the black level auto-zero loop is in operation. The duty cycle (D) must be considered as the loop operates in a sampled mode. Operation of the black level auto-zero loop is activated by the OB signal that happens once during each horizontal line interval.

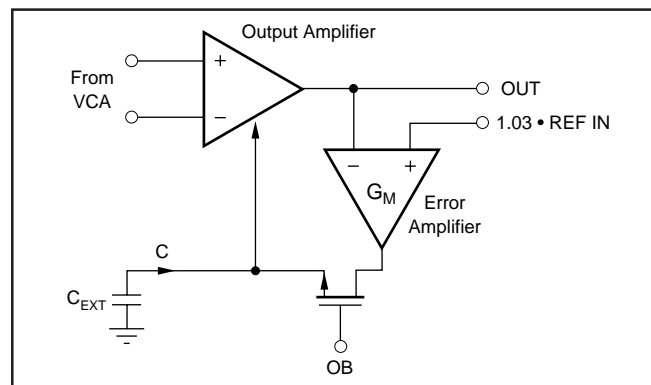

FIGURE 4. Simplified Block Diagram of Optical Black Level Auto-Zero Loop

## DECOUPLING AND GROUNDING CONSIDERATIONS

Figure 5 shows the recommended decoupling scheme for the VSP2080. In most cases, 0.1 $\mu$ F ceramic chip capacitors are adequate to keep the impedance low over a wide frequency range. Their effectiveness largely depends on the

proximity to the individual pin. Therefore, they should be located as close as possible to the pins. In addition, one larger capacitor (1 $\mu$ F to 22 $\mu$ F) should be connected from  $V_{DDA}$  to ground and placed on the PC board in proximity of the VSP2080.

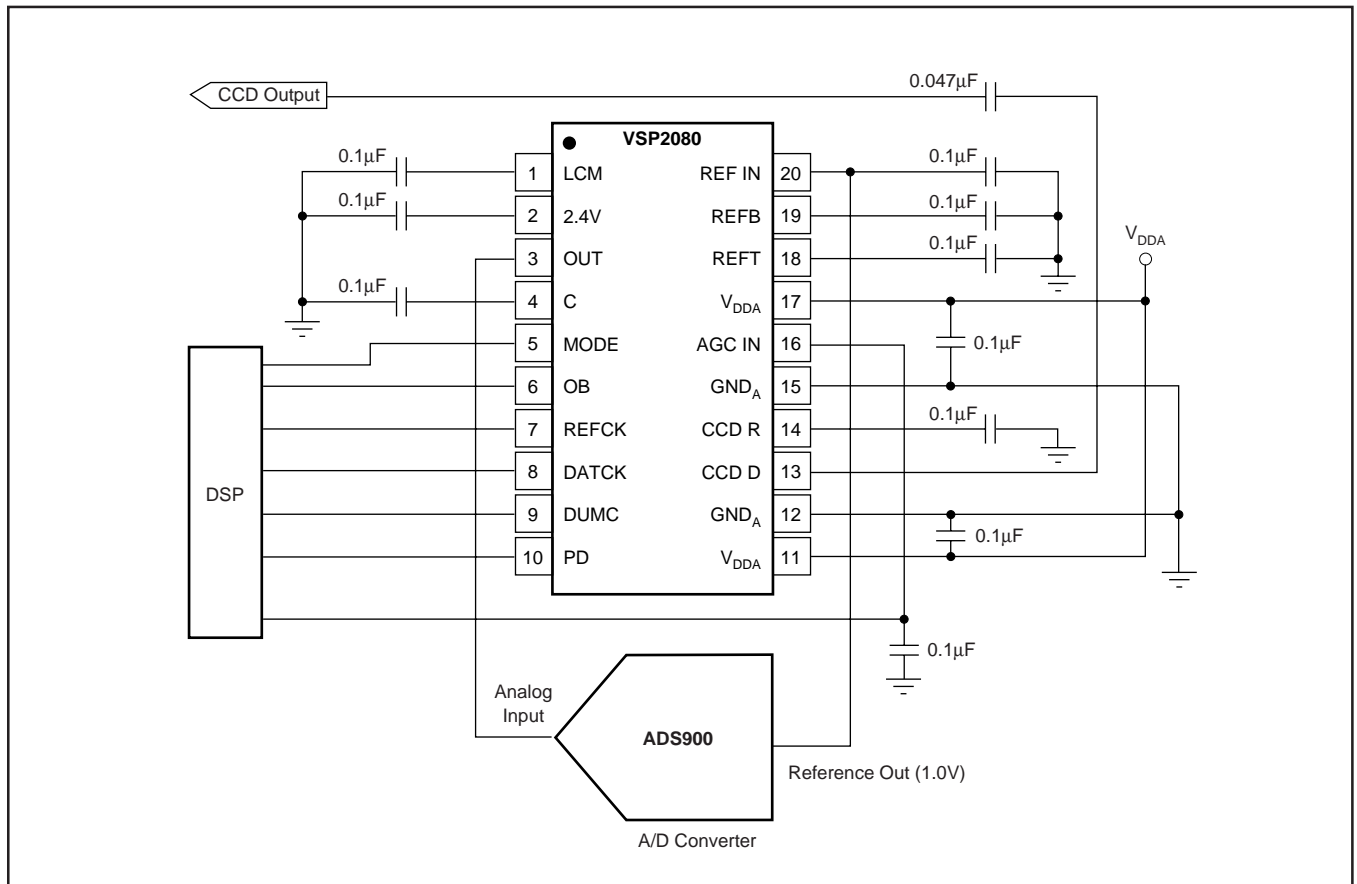

FIGURE 5. VSP2080 Typical Application and Bypassing Requirements.