

# VTP Process Photodiodes

# VTP8440

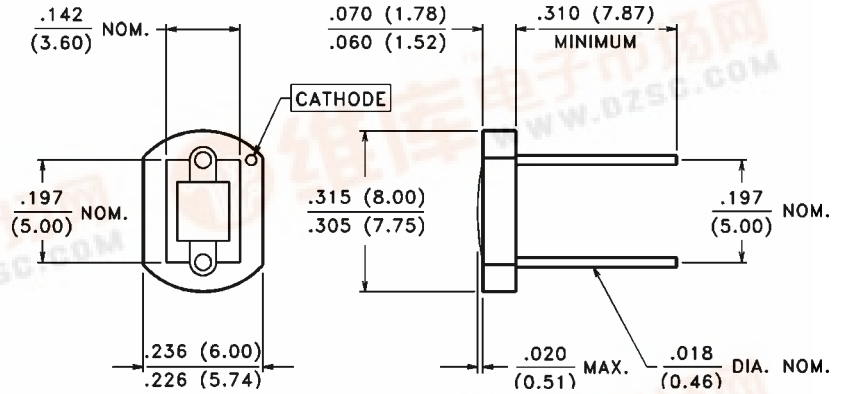

## PACKAGE DIMENSIONS inch (mm)



CASE 21 8 mm CERAMIC  
CHIP ACTIVE AREA: .008 in<sup>2</sup> (5.16 mm<sup>2</sup>)

## PRODUCT DESCRIPTION

Planar silicon photodiode in a recessed ceramic package. Chip is coated with a protective layer of clear epoxy. These diodes exhibit low dark current under reverse bias and fast speed of response.

## ABSOLUTE MAXIMUM RATINGS

Storage Temperature: -20°C to 75°C  
Operating Temperature: -20°C to 75°C

## ELECTRO-OPTICAL CHARACTERISTICS @ 25°C (See also VTP curves, page 46)

SYMBOL	CHARACTERISTIC	TEST CONDITIONS	VTP8440			UNITS
			Min.	Typ.	Max.	
I <sub>SC</sub>	Short Circuit Current	H = 100 fc, 2850 K	30	55		μA
TC I <sub>SC</sub>	I <sub>SC</sub> Temperature Coefficient	2850 K		.20		%/°C
V <sub>OC</sub>	Open Circuit Voltage	H = 100 fc, 2850 K		350		mV
TC V <sub>OC</sub>	V <sub>OC</sub> Temperature Coefficient	2850 K		-2.0		mV/°C
I <sub>D</sub>	Dark Current	H = 0, V <sub>R</sub> = 50 V			15	nA
R <sub>SH</sub>	Shunt Resistance	H = 0, V = 10 mV		.5		GΩ
C <sub>J</sub>	Junction Capacitance	H = 0, V = 15 V			15	pF
Re	Responsivity	940 nm		.025		A/(W/cm <sup>2</sup> )
S <sub>R</sub>	Sensitivity	@ Peak		.55		A/W
λ <sub>range</sub>	Spectral Application Range		400		1150	nm
λ <sub>p</sub>	Spectral Response - Peak			925		nm
V <sub>BR</sub>	Breakdown Voltage		50	140		V
θ <sub>1/2</sub>	Angular Resp. - 50% Resp. Pt.			±50		Degrees
NEP	Noise Equivalent Power			1.3 x 10 <sup>-13</sup> (Typ.)		W/√Hz
	Specific Detectivity			1.8 x 10 <sup>12</sup> (Typ.)		cm√Hz / W

