

STR-W6754

Universal-Input/100 W Off-Line Quasi-Resonant Flyback Switching Regulator

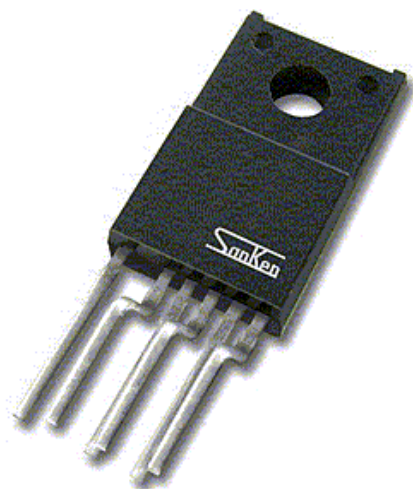

ABSOLUTE MAXIMUM RATINGS at $T_A = +25^\circ\text{C}$

Control Supply Voltage, V_{CC}	35 V
Drain-Source Voltage, V_{DSS}	650 V
Drain Switching Current, I_D	15 A*
Peak Drain Switching Current, I_{DM}	15 A
Single-Pulse Avalanche Energy, E_{AS}	292 mJ
OCP/BD Voltage Range, V_{OCP}	-1.5 V to +5 V
FB Input Current, I_{FB}	10 mA
FB Voltage Range, V_{FP}	-0.5 V to +9 V
Package Power Dissipation, P_D control ($V_{CC} \times I_{CC(ON)}$)	0.8 W
MOSFET ($V_{DSS} \times I_D$)	See Graph
MOSFET Channel Temp., T_J	+150°C
Internal Frame Temp., T_F	+115°C
Operating Temperature Range, T_A	-20°C to +115°C
Storage Temperature Range, T_S	-40°C to +125°C

* Drain switching current is limited by temperature (page 2) and safe operating area (page 5).
†For the availability of parts meeting -40°C requirements, contact Allegro's Sales Representative.

The STR-W6754 is a quasi-resonant regulator specifically designed to satisfy the requirements for increased integration and reliability in switch-mode power supplies. It incorporates a primary control and drive circuit with an avalanche-rated power MOSFET. The regulator exhibits only low-level high-frequency EMI noise because of soft switching of the MOSFET close to ground (bottom point). A bottom-skip function minimizes an increase of operational frequency during light loads to improve system efficiency over the entire load range.

Covering the power range from below 160 watts for a 230 VAC input, or 100 watts for a universal input (85 to 264 VAC), this device can be used in a range of applications, from DVD and VCR players to ac adapters for cellular phones and digital cameras. An auto-standby function, which is internally triggered by sensing on time, reduces power consumption at light load. An externally triggered standby mode reduces the input power further. Multiple protections, including the avalanche-energy-guaranteed MOSFET, provide high reliability of system design. Devices with an increased output power rating are the STR-W6756.

Cycle-by-cycle current limiting, undervoltage lockout with hysteresis, and overvoltage protection protect the power supply during the normal overload and fault conditions. Overvoltage protection is latched after a short delay. The latch may be reset by cycling the input supply. Low start-up current and a low-power standby mode selected from the secondary circuit completes a comprehensive suite of features. The STR-W6754 is provided in a fully molded TO-220-style flange-mounted, high power, isolated plastic package.

FEATURES AND BENEFITS

- Rugged 650 V Avalanche-Rated MOSFET
Simplified Surge Absorption
No V_{DSS} Derating Required
- 0.96 Ω Maximum $r_{DS(on)}$
- Two Operational Modes by Automatic Switching:
Quasi-Resonant Mode for Normal Operation
Burst Mode for Standby Operation or Light Loads
- Automatic or Manually Triggered Burst Standby
Input Power <0.1 W at No Load
- Low Operating Current (6 mA typ)

— continued

Always order by complete part number, e.g., **STR-W6754** .

STR-W6754
Universal-Input/100 W Off-Line Quasi-Resonant Flyback Switching Regulator

*Switching
Regulators*

FUNCTIONAL BLOCK DIAGRAM

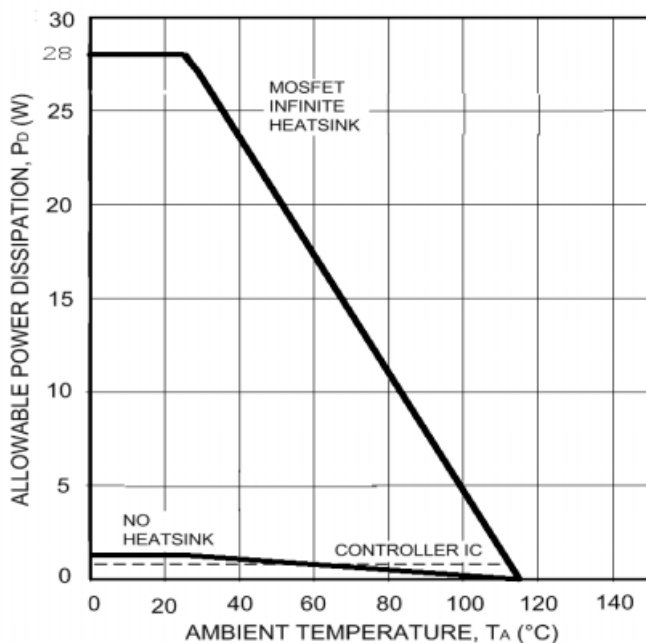
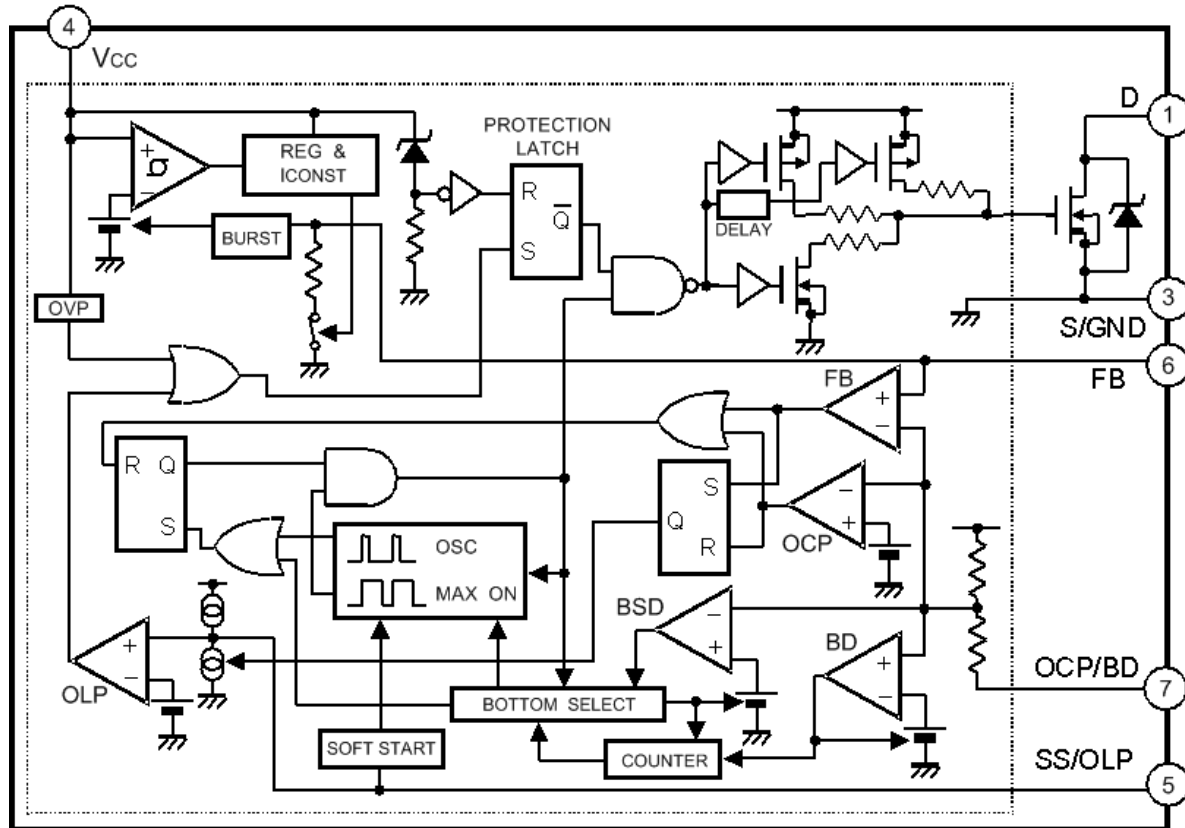

FEATURES AND BENEFITS (cont'd)

- Auto-Bias Function
Stable Burst Operation Without Generating Interference
- Internal Off-Timer Circuit
- Built-In Constant-Voltage Drive
- Multiple Protections:
 - Pulse-by-Pulse Overcurrent Protection
 - Overload Protection with Auto Recovery
 - Latching Overvoltage Protection
 - Undervoltage Lockout with Hysteresis
- RoHS Compliant

ELECTRICAL CHARACTERISTICS at $T_A = +25^\circ\text{C}$, $V_{CC} = 20\text{ V}$, voltage measurements are referenced to S/GND terminal (unless otherwise specified).

Characteristic	Symbol	Test Conditions	Limits			
			Min.	Typ.	Max.	Units
Start-Up Operation						
Operation Start Voltage	$V_{CC(ON)}$	Turn-on, $V_{CC} = 0 \rightarrow 19.9\text{ V}$	16.3	18.2	19.9	V
Soft-Start Operation Stop Voltage	$V_{SS/OLP}$		1.1	1.2	1.4	V
Soft-Start Oper. Charging Current	$I_{SS/OLP}$		-390	-550	-710	μA
Operation Stop Voltage	$V_{CC(OFF)}$	Turn-off, $V_{CC} = 19.9 \rightarrow 8.8\text{ V}$	8.8	9.7	10.6	V
Circuit Current in Non-Operation	$I_{CC(OFF)}$	$V_{CC} = 15\text{ V}$	–	–	100	μA
Normal Operation						
Drain-Source Breakdown Voltage	$V_{(BR)DSS}$	$I_D = 300\ \mu\text{A}$	650	–	–	V
Drain Leakage Current	I_{DSS}	$V_{DS} = 650\text{ V}$	–	–	300	μA
On-State Resistance	$r_{DS(on)}$	$I_D = 1.9\text{ A}$, $T_J = +25^\circ\text{C}$	–	–	0.96	Ω
Switching Time	t_f		–	–	400	ns
Circuit Current	$I_{CC(ON)}$		–	–	6.0	mA
Oscillation Frequency	f_{osc}		19	22	25	kHz
Bottom-Skip Oper. Threshold Volt.	$V_{OCPBD(BS1)}$		-605	-665	-720	mV
	$V_{OCPBD(BS2)}$		-385	-435	-485	mV
Quasi-Resonant Oper. Threshold	$V_{OCPBD(TH1)}$		280	400	520	mV
	$V_{OCPBD(TH2)}$		670	800	930	mV
Feedback-Pin Threshold Voltage	$V_{FB(OFF)}$		1.32	1.45	1.58	V
Feedback-Pin Current	$I_{FB(ON)}$		600	1000	1400	μA
Standby Operation						
Standby Operation Start Voltage	$V_{CC(S)}$	$V_{CC} = 0 \rightarrow 12.2\text{ V}$	10.3	11.1	12.1	V
Standby Oper. Start Volt. Interval	V_{CC}		1.10	1.35	1.65	V
Standby Non-Operation Current	$I_{CC(S)}$	$V_{CC} = 10.2\text{ V}$	–	20	56	μA
Feedback-Pin Current	$I_{FB(ON)}$	$V_{CC} = 10.2\text{ V}$	–	4.0	14	μA
Feedback-Pin Threshold Voltage	$V_{FB(S)}$	$V_{CC} = 12.2\text{ V}$	0.55	1.10	1.50	V
Minimum ON Time	$t_{on(min)}$		0.5	0.8	1.2	μs

continued next page ...

STR-W6754
Universal-Input/100 W Off-Line Quasi-Resonant Flyback Switching Regulator

Switching
Regulators

ELECTRICAL CHARACTERISTICS at $T_A = +25^\circ\text{C}$, $V_{CC} = 20\text{ V}$, voltage measurements are referenced to S/GND terminal (unless otherwise specified).

Characteristic	Symbol	Test Conditions	Limits			
			Min.	Typ.	Max.	Units
Protection Operation						
OVP Operation Voltage	$V_{CC(OVP)}$	Turn-off, $V_{CC} = 0 \rightarrow 29.9\text{ V}$	25.5	27.7	29.9	V
Maximum ON Time	$t_{on(max)}$		27.5	32.5	39.0	μs
OLP Operation Voltage	V_{SSOLP}		4.0	4.9	5.8	V
OLP Operation Current	I_{SSOLP}		-6.0	-11	-16	μA
Overcurrent Detect. Threshold Volt.	$V_{OCPBD(LIM)}$		-0.895	-0.940	-0.995	V
OCP/BD-Pin Current	I_{OCPBD}		-40	-100	-250	μA
Latch Holding Current	$I_{CC(H)}$	$V_{CC} = 29.9 \rightarrow V_{CC(OFF)} - 0.3\text{ V}$	-	45	140	mA
Latch Release Voltage	$V_{CC(L)}$	$V_{CC} = 29.9 \rightarrow 6\text{ V}$	6.0	7.2	8.5	V
Other						
Thermal Resistance	$R_{\theta JF}$	Output junction-to-frame	-	-	1.6	$^\circ\text{C/W}$

- NOTES: 1. Typical Data is for design information only.
 2. Negative current is defined as coming out of (sourcing) the specified device terminal.

MOSFET TYPICAL CHARACTERISTICS

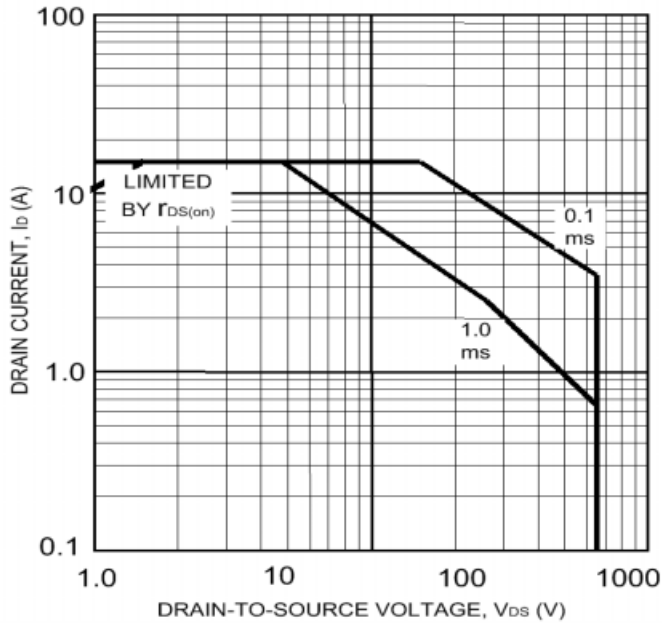

Avalanche energy is measured at $V_{DD} = 99$ V,
 $L = 20$ mH, $I_L = 5.1$ A.

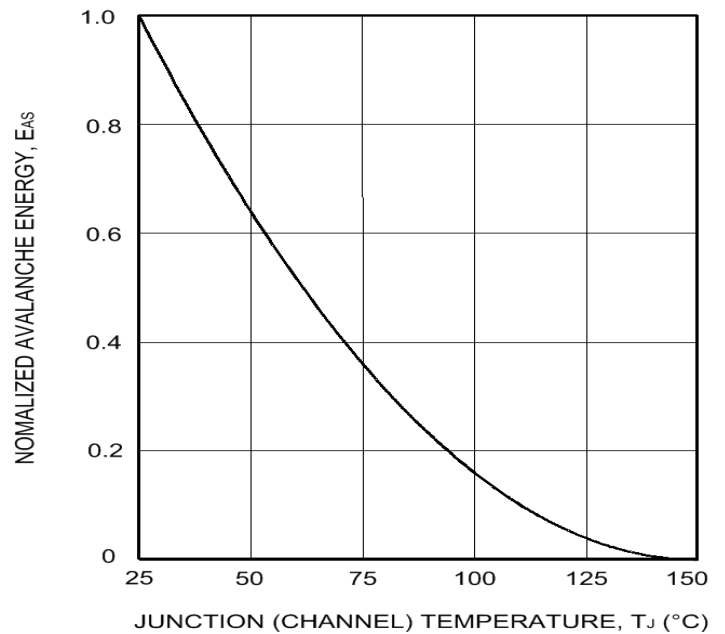
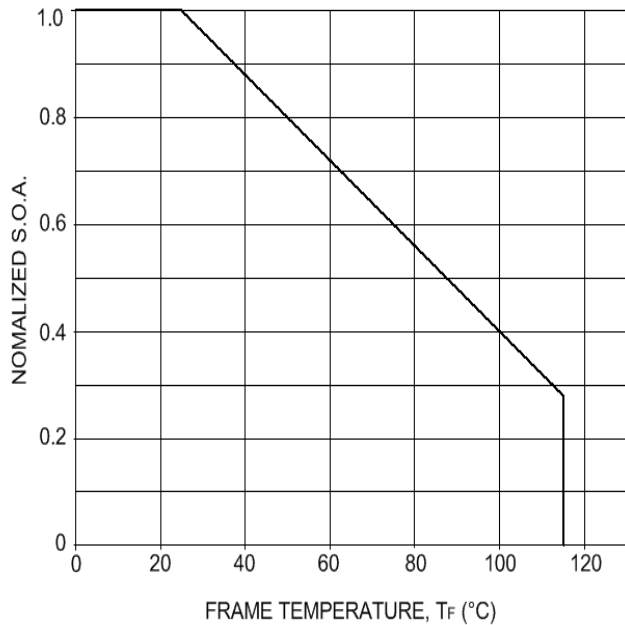

STR-W6754
Universal-Input/100 W Off-Line Quasi-Resonant Flyback Switching Regulator

**Switching
Regulators**

MOSFET TYPICAL CHARACTERISTICS (cont'd)

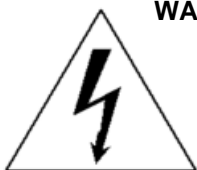
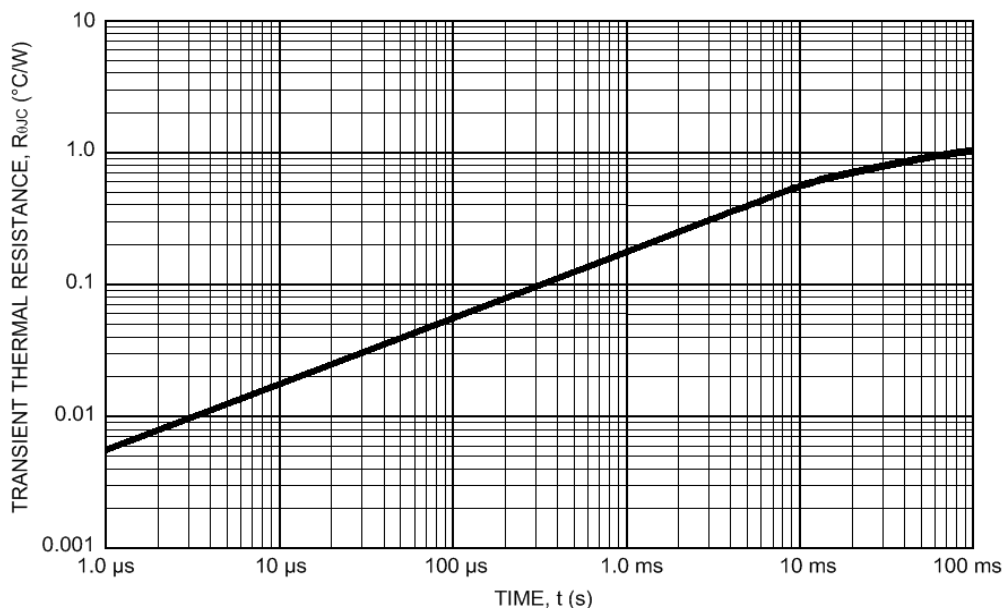

WARNING — These devices are designed to be operated at lethal voltages and energy levels. Circuit designs that embody these components must conform with applicable safety requirements. Precautions must be taken to prevent accidental contact with power-line potentials. Do not connect grounded test equipment.

The use of an isolation transformer is recommended during circuit development and breadboarding.

APPLICATIONS INFORMATION

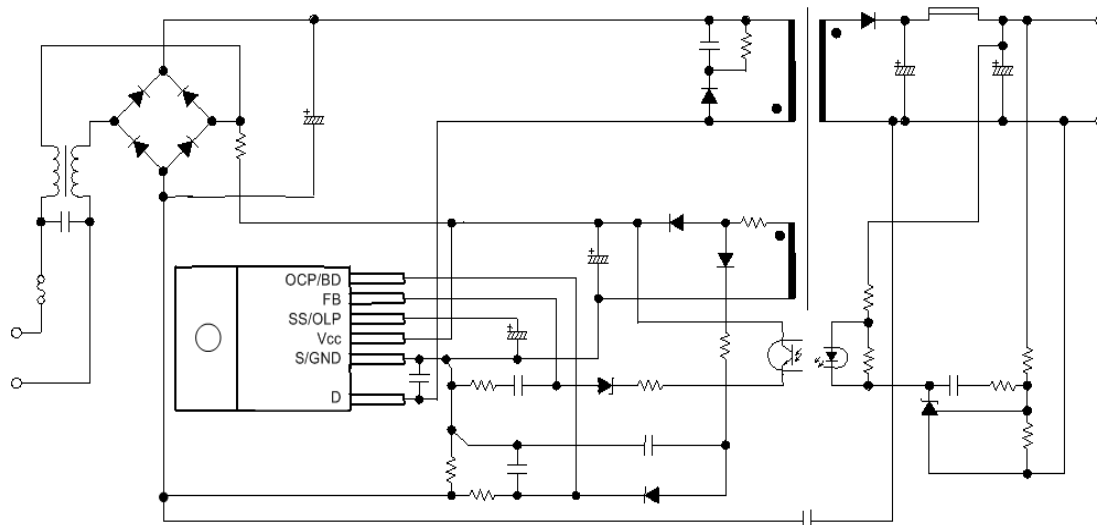

Typical Application

Complete product description and applications information is provided in Application Note 28103.30, *Series STR-W6750 Off-Line Quasi-Resonant Flyback Switching Regulators*.

The products described herein are manufactured in Japan by Sanken Electric Co., Ltd. for sale by Allegro MicroSystems, Inc.

Sanken and Allegro reserve the right to make, from time to time, such departures from the detail specifications as may be required to permit improvements in the performance, reliability, or manufacturability of its products. Therefore, the user is cautioned to verify that the information in this publication is current before placing any order.

When using the products described herein, the applicability and suitability of such products for the intended purpose shall be reviewed at the users responsibility.

Although Sanken undertakes to enhance the quality and reliability of its products, the occurrence of failure and defect of semiconductor products at a certain rate is inevitable.

Users of Sanken products are requested to take, at their own risk, preventative measures including safety design of the equipment or systems against any possible injury, death, fires or damages to society due to device failure or malfunction.

Sanken products listed in this publication are designed and intended for use as components in general-purpose electronic equipment or apparatus (home appliances, office equipment, telecommunication equipment, measuring equipment, etc.). Their use in any application requiring radiation hardness assurance (e.g., aerospace equipment) is not supported.

When considering the use of Sanken products in applications where higher reliability is required (transportation equipment and its control systems or equipment, fire- or burglar-alarm systems, various safety devices, etc.), contact a company sales representative to discuss and obtain written confirmation of your specifications.

The use of Sanken products without the written consent of Sanken in applications where extremely high reliability is required (aerospace equipment, nuclear power-control stations, life-support systems, etc.) is strictly prohibited.

The information included herein is believed to be accurate and reliable. Application and operation examples described in this publication are given for reference only and Sanken and Allegro assume no responsibility for any infringement of industrial property rights, intellectual property rights, or any other rights of Sanken or Allegro or any third party that may result from its use.

STR-W6754
Universal-Input/100 W Off-Line Quasi-Resonant Flyback Switching Regulator

**Switching
 Regulators**

PACKAGE DIMENSIONS
in Millimeters

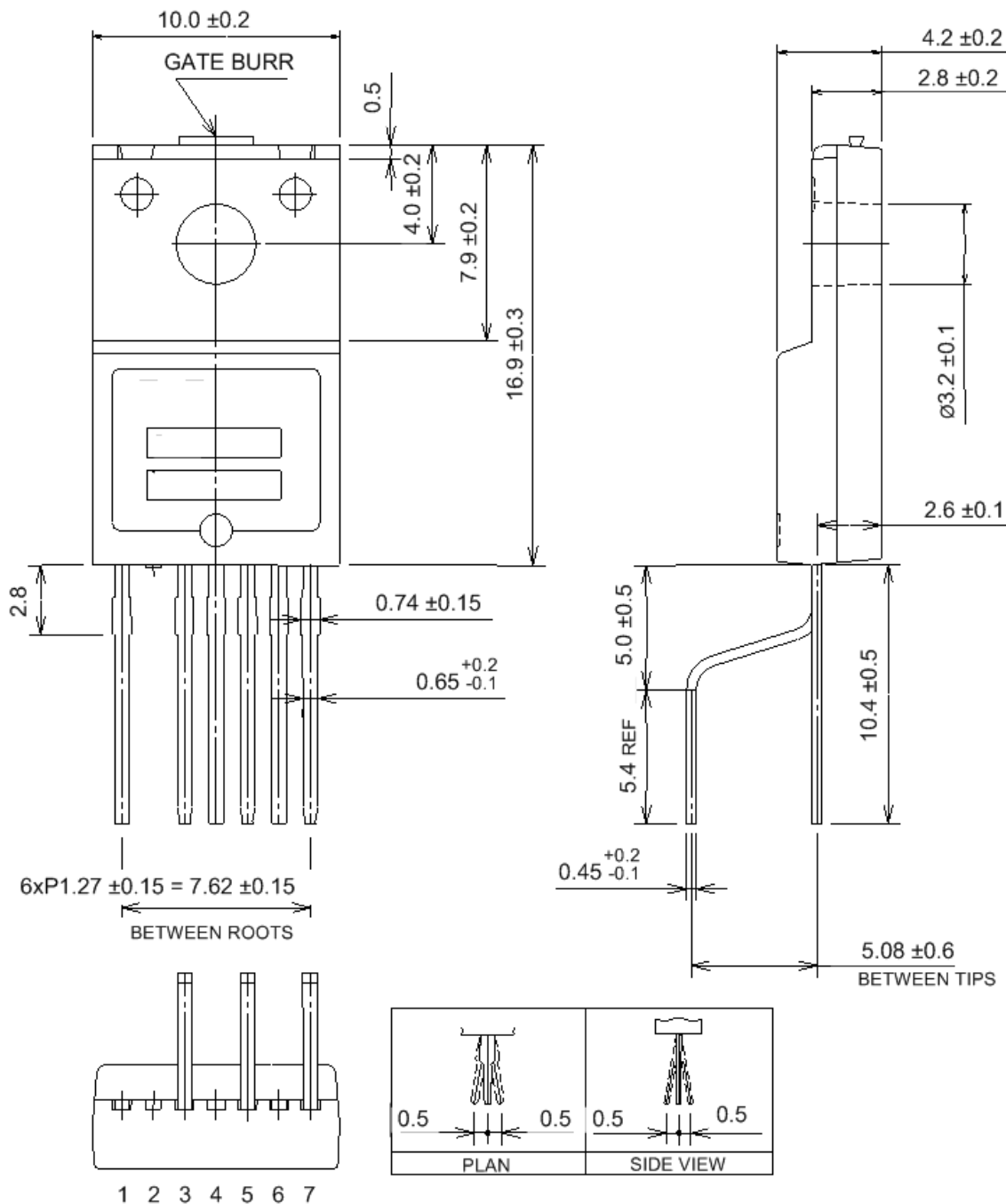

Product weight: approx. 2.3 g.

Recommended mounting hardware torque: 0.588 ~ 0.785 Nm, 6 ~ 8 kgf × cm.

Recommended silicon grease: Dow Corning SC102, Toshiba YG6260, Shin-Etsu G746, or equivalent.

Copyright © Each Manufacturing Company.

All Datasheets cannot be modified without permission.

This datasheet has been download from :

www.AllDataSheet.com

100% Free DataSheet Search Site.

Free Download.

No Register.

Fast Search System.

www.AllDataSheet.com