



## 4-BIT MICROCONTROLLER

### *Table of Contents--*

GENERAL DESCRIPTION .....	2
FEATURES.....	2
PIN CONFIGURATION .....	3
PIN DESCRIPTION.....	4
BLOCK DIAGRAM .....	5
FUNCTIONAL DESCRIPTION .....	6
ABSOLUTE MAXIMUM RATINGS .....	34
DC CHARACTERISTICS.....	35
AC CHARACTERISTICS.....	36
PAD ASSIGNMENT & POSITIONS .....	37
TYPICAL APPLICATION CIRCUIT.....	39
INSTRUCTION SET TABLE .....	40
PACKAGE DIMENSION .....	90



## GENERAL DESCRIPTION

The W741C260 is a high-performance 4-bit microcontroller ( $\mu\text{C}$ ) with an LCD driver. The device contains a 4-bit ALU, two 8-bit timers, two dividers, a  $32 \times 4$  LCD driver, and five 4-bit I/O ports (including 1 output port to drive the LEDs). There are also five interrupt sources and 8-level subroutine nesting for interrupt applications. The W741C260 has two power reduction modes, hold mode and stop mode, which help to minimize power dissipation.

The W741C260 has two oscillator circuits and can work in dual-clock or single-clock operation mode. It is suitable for remote controllers, watches and clocks, speech synthesis LSI controllers, hand-held games and other products.

## FEATURES

- Operating voltage: 2.2V to 5.5V (LCD drive voltage: 3.0V, or 4.5V)
- Operating frequency up to 4 MHz
- Crystal/RC oscillation circuit selectable by code option for system clock
- 32.768 KHz crystal oscillation circuit for sub-oscillator
- High-frequency clock (400 KHz to 4 MHz) or low-frequency clock (32.768 KHz) for crystal mode; selectable by code option
- Memory
  - 2048  $\times$  16 bit program ROM (including 2K  $\times$  4 bit look-up table)
  - 128  $\times$  4 bit data RAM (including 16 working registers)
  - 32  $\times$  4 LCD data RAM
- 21 input/output pins
  - Ports for input only: 2 ports/8 pins
  - Input/output ports: 2 ports/8 pins
  - Port for output only: 1 port /4 pins (high sink current to drive LEDs)
  - MFP output pin: 1 pin (MFP)
- Power-down mode
  - Hold function: no operation (except for oscillator)
  - Stop function: no operation (including main oscillator)
- Five types of interrupts
  - Four internal interrupts (Divider 0, Divider 1, Timer 0, Timer 1)
  - One external interrupt (Port RC)
- LCD driver output
  - 32 segment  $\times$  4 common
  - Static, 1/2 duty (1/2 bias), 1/3 duty (1/2 or 1/3 bias), 1/4 duty (1/3 bias) driving mode can be selected
  - LCD driver output pins can be used as DC output ports; selectable by code option



- MFP output pin
  - Output is software selectable as modulating or nonmodulating frequency
  - Works as frequency output specified by Timer 1
- Two built-in 14-bit clock frequency divider circuit (divider 0 and divider 1)
- Two built-in 8-bit programmable countdown timers
  - Timer 0: one of two internal clock frequencies ( $F_{osc}/4$  or  $F_{osc}/1024$ ) can be selected
  - Timer 1: includes an auto-reload function; and one of two internal clock frequencies ( $F_{osc}$  or  $F_{osc}/64$ ) can be selected or falling edge of pin RC.0 can be selected (output through MFP pin)
- Built-in 18/14-bit watchdog timer selectable for system reset
- Powerful instruction set: 118 instructions
- 8-level subroutine (include interrupt) nesting
- Up to 1  $\mu$ S instruction cycle (with 4 MHz operating frequency)
- Packaged in 80-pin QFP

## PIN CONFIGURATION

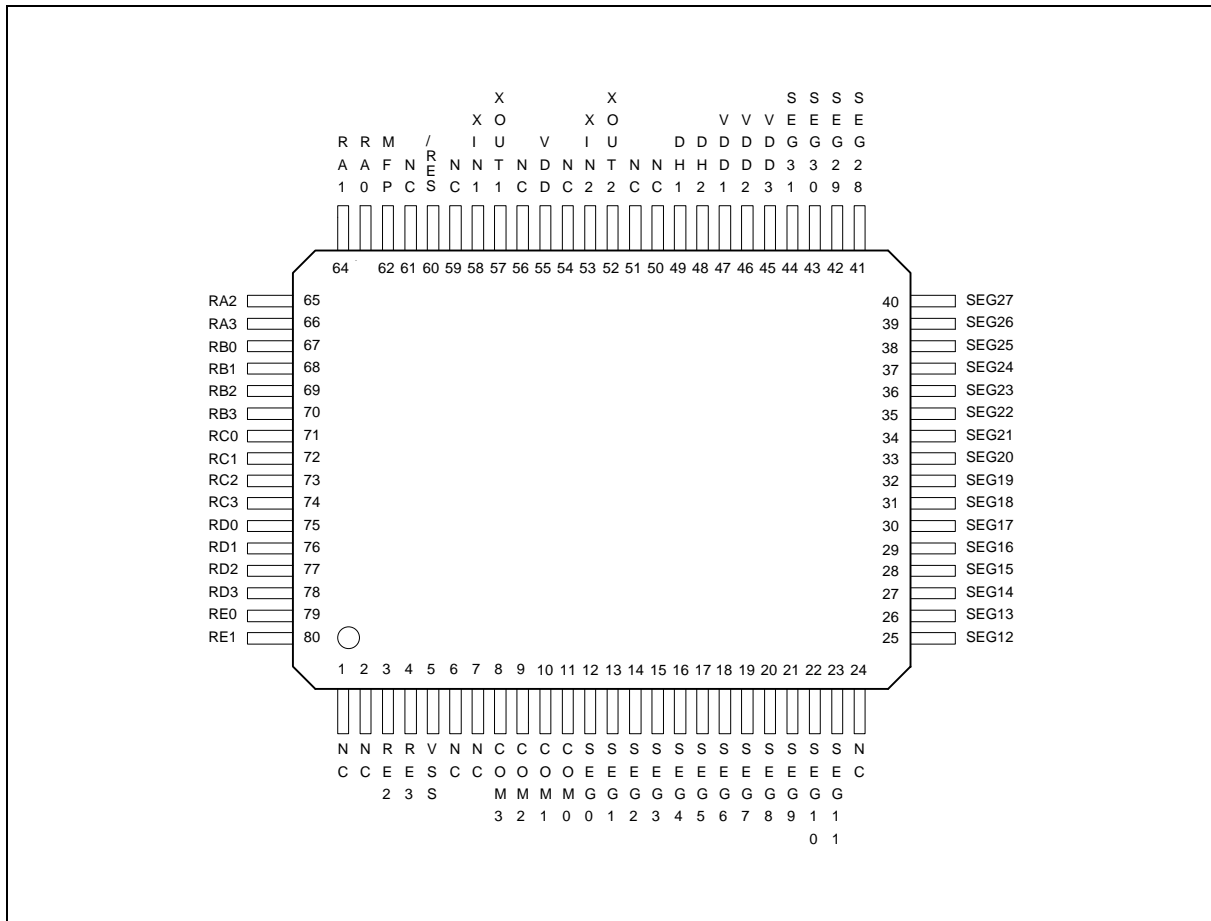



## PIN DESCRIPTION

SYMBOL	I/O	FUNCTION																									
XIN1	I	Input pin for oscillator. Connected to crystal or resistor to generate system clock by code option.																									
XOUT1	O	Output pin for oscillator. Connected to crystal or resistor to generate system clock by code option.																									
XIN2	I	Input pin for sub-oscillator. Connected to a 32.768 KHz crystal.																									
XOUT2	O	Output pin for sub-oscillator. Connected to a 32.768 KHz crystal.																									
RA0–RA3	I/O	Input/Output port. Input/output mode specified by port mode 1 register (PM1).																									
RB0–RB3	I/O	Input/Output port. Input/output mode specified by port mode 2 register (PM2).																									
RC0–RC3	I	4-bit port for input only. Each pin has an independent interrupt capability.																									
RD0–RD3	I	4-bit port for input only.																									
RE0–RE3	O	Output port only. This port provides high sink current to drive LEDs.																									
MFP	O	Output pin only. This pin can output modulating or nonmodulating frequency, or Timer 1 clock output specified by mode register 1 (MR1).																									
$\overline{\text{RES}}$	I	System reset pin with pull-high resistor.																									
SEG0–SEG31	O	LCD segment output pins. Can also be used as DC output ports specified by code option.																									
COM0–COM3	O	LCD common signal output pins. <table border="1" style="margin-left: 20px;"> <thead> <tr> <th></th> <th>Static</th> <th>1/2 Duty</th> <th>1/3 Duty</th> <th>1/4 Duty</th> </tr> </thead> <tbody> <tr> <td>COM0</td> <td>Used</td> <td>Used</td> <td>Used</td> <td>Used</td> </tr> <tr> <td>COM1</td> <td>Not Used</td> <td>Used</td> <td>Used</td> <td>Used</td> </tr> <tr> <td>COM2</td> <td>Not Used</td> <td>Not Used</td> <td>Used</td> <td>Used</td> </tr> <tr> <td>COM3</td> <td>Not Used</td> <td>Not Used</td> <td>Not Used</td> <td>Used</td> </tr> </tbody> </table> <p>The LCD alternating frequency can be selected by code option.</p>		Static	1/2 Duty	1/3 Duty	1/4 Duty	COM0	Used	Used	Used	Used	COM1	Not Used	Used	Used	Used	COM2	Not Used	Not Used	Used	Used	COM3	Not Used	Not Used	Not Used	Used
	Static	1/2 Duty	1/3 Duty	1/4 Duty																							
COM0	Used	Used	Used	Used																							
COM1	Not Used	Used	Used	Used																							
COM2	Not Used	Not Used	Used	Used																							
COM3	Not Used	Not Used	Not Used	Used																							
DH1, DH2	I	Connection terminals for voltage doubler (halver) capacitor.																									
VDD1, VDD2, VDD3	I	Positive (+) supply voltage terminal. Refer to Functional Description.																									
VDD	I	Positive power supply (+).																									
VSS	I	Negative power supply (-).																									

**BLOCK DIAGRAM**

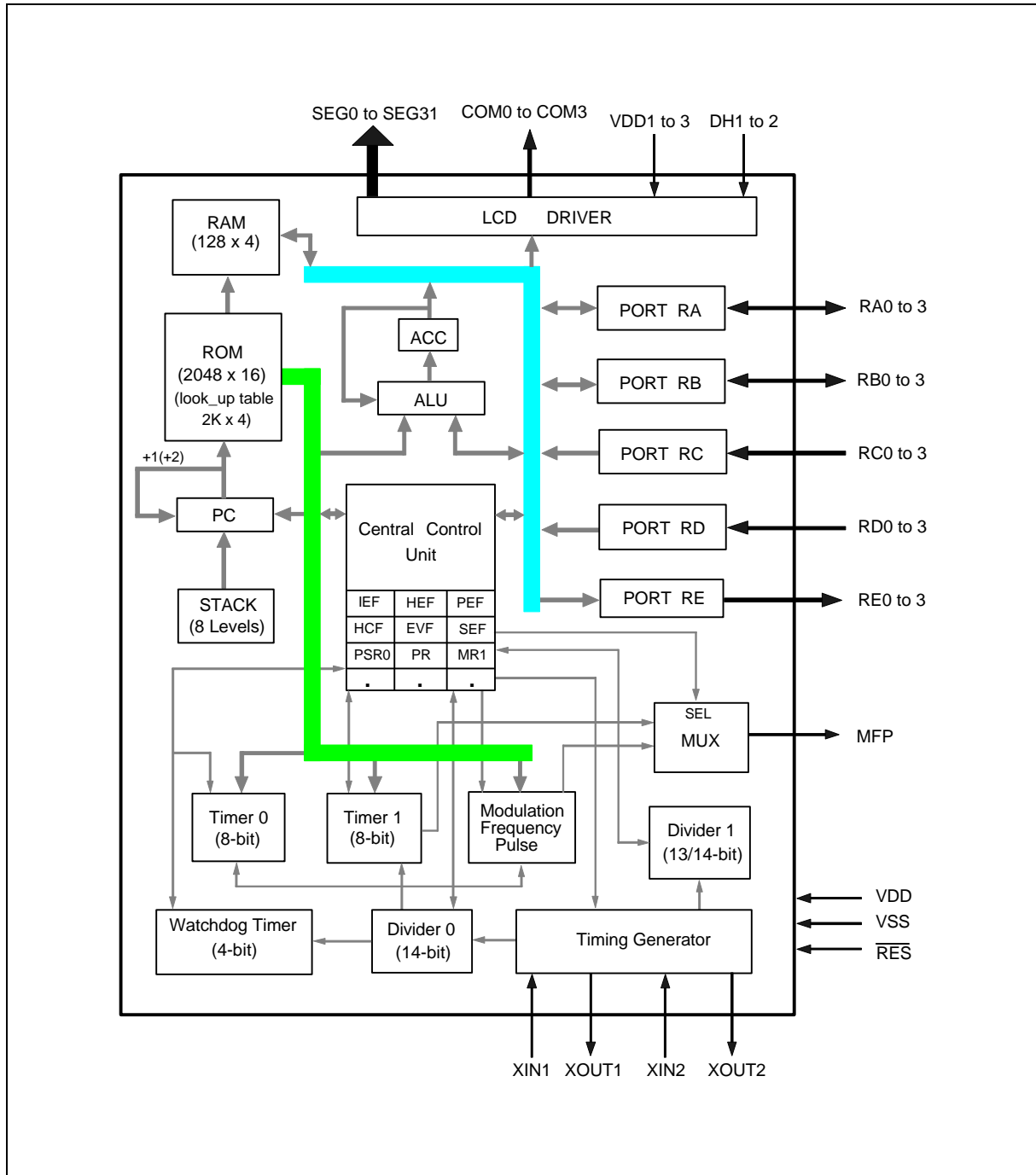



## FUNCTIONAL DESCRIPTION

### Program Counter (PC)

Organized as an 11-bit binary counter (PC0 to PC10), the program counter generates the addresses of the 2048 × 16 on-chip ROM containing the program instructions. When the jump or subroutine call instructions or the interrupt or initial reset conditions are to be executed, the address corresponding to the instruction will be loaded into the program counter. The format used is shown below.

ITEM	ADDRESS	INTERRUPT PRIORITY
Initial Reset	000H	-
INT 0 (Divider 0)	004H	1st
INT 1 (Timer 0)	008H	2nd
INT 2 (Port RC)	00CH	3rd
INT 4 (Divider 1)	014H	4th
INT 7 (Timer 1)	020H	5th
JP Instruction	XXXH	-
Subroutine Call	XXXH	-

### Stack Register (STACK)

The stack register is organized as 11 bits × 8 levels (first-in, last-out). When either a call subroutine or an interrupt is executed, the program counter will be pushed onto the stack register automatically. At the end of a call subroutine or an interrupt service subroutine, the RTN instruction must be executed to pop the contents of the stack register into the program counter. When the stack register is pushed over the eighth level, the contents of the first level will be lost. In other words, the stack register is always eight levels deep.

### Program Memory (ROM)

The read-only memory (ROM) is used to store program codes; the look-up table is arranged as 2048 × 4 bits. The first three quarters of ROM (000H to 5FFH) are used to store instruction codes only, but the last quarter (600H to 7FFH) can store both instruction codes and the look-up table. Each look-up table element is composed of 4 bits, so the look-up table can be addressed up to 2048 elements. There are two registers (TABL and TABH) to be used in look-up table addressing and they are controlled by MOV TABH, R and MOV TABL, R instructions. When the instruction MOVC R is executed, the contents of the look-up table location address specified by TABH, TABL and ACC will be read and transferred to the data RAM. Refer to the instruction table for more details. The organization of the program memory is shown in Figure 1.

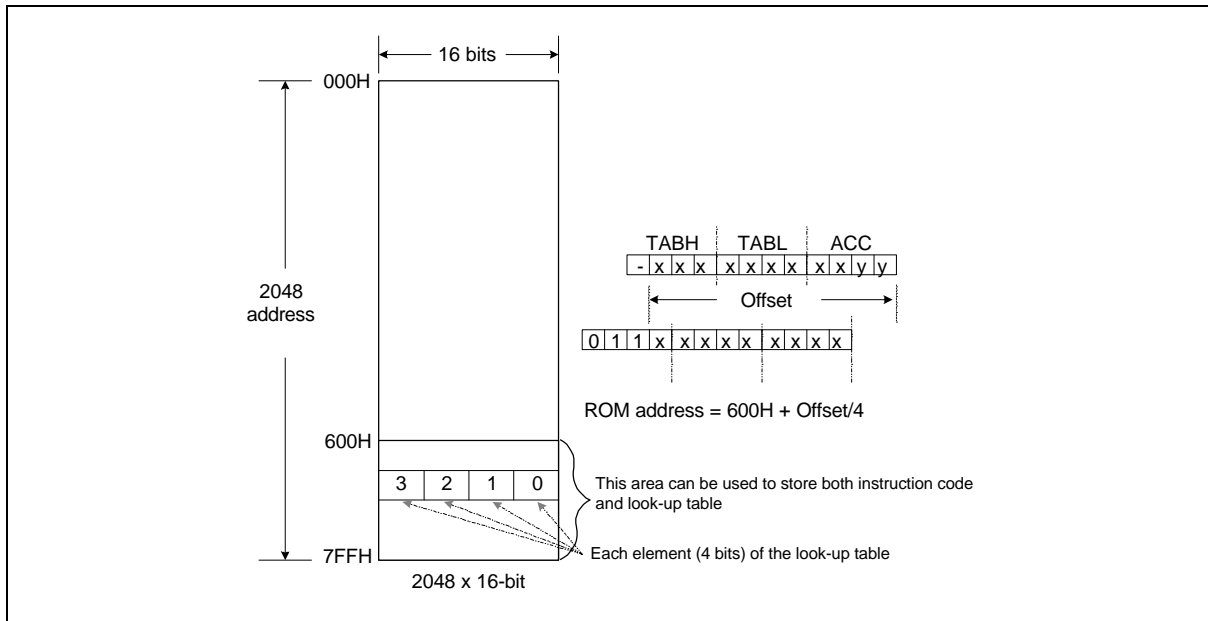

Figure 1. Program Memory Organization

## Data Memory (RAM)

### 1. Architecture

The static data memory (RAM) used to store data is arranged as 128 × 4 bits. The data memory can be addressed directly or indirectly. The organization of the data memory is shown in Figure 2.

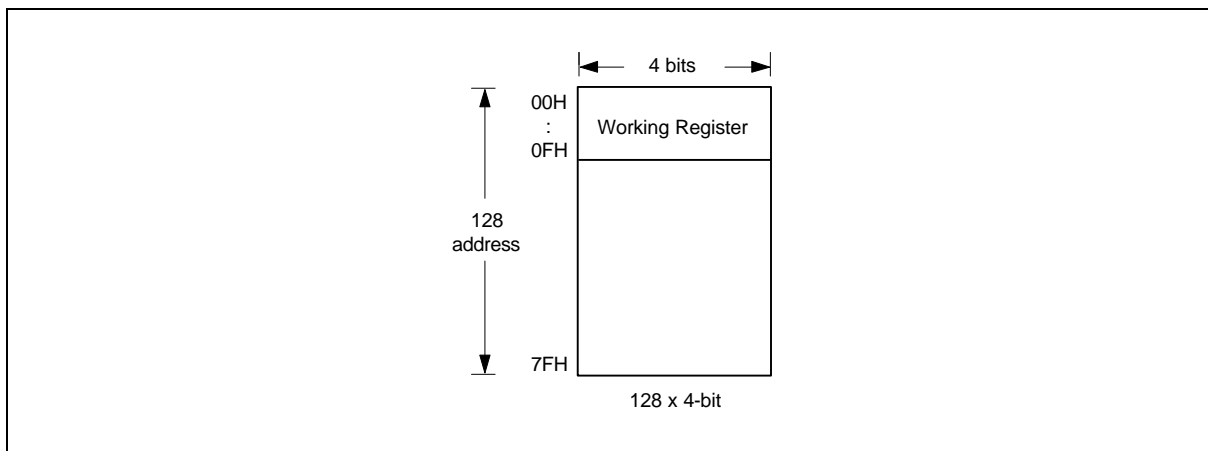

Figure 2. Data Memory Organization

The first sixteen addresses (00H to 0FH) in the data memory are known as the working registers (WR). The other data memory is used as general memory and cannot operate directly with immediate data. The relationship between data memory locations and the page register (PAGE) in indirect addressing mode is described in the next section.



## 2. Page Register (PAGE)

The page register is organized as a 4-bit binary register. The bit descriptions are as follows:

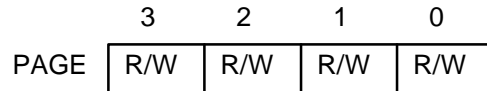

Note: R/W means read/write available.

Bit 3 is reserved.

Bit 2, Bit 1, Bit 0 Indirect addressing mode preselect bits:

000 = Page 0 (00H–0FH)	001 = Page 1 (10H–1FH)
010 = Page 2 (20H–2FH)	011 = Page 3 (30H–3FH)
100 = Page 4 (40H–4FH)	101 = Page 5 (50H–5FH)
110 = Page 6 (60H–6FH)	111 = Page 7 (70H–7FH)

## Accumulator (ACC)

The accumulator (ACC) is a 4-bit register used to hold results from the ALU and transfer data between the memory, I/O ports, and registers.

## Arithmetic and Logic Unit (ALU)

This is a circuit which performs arithmetic and logic operations. The ALU provides the following functions:

- Logic operations: ANL, XRL, ORL
- Branch decisions: JB0, JB1, JB2, JB3, JNZ, JZ, JC, JNC, DSKZ, DSKNZ, SKB0, SKB1, SKB2, SKB3
- Shift operations: SHRC, RRC, SHLC, RLC
- Binary additions/subtractions: ADC, SBC, ADD, SUB, ADU, DEC, INC

After any of the above instructions are executed, the status of the carry flag (CF) and zero flag (ZF) is stored in the internal registers. Otherwise CF can be stored or be read out by executing MOVA R, CF or MOV CF, R.

## Clock Generator

The W741C260 provides two oscillation circuits, main-oscillator and sub-oscillator. The main-oscillator can select the crystal or RC oscillation circuit by option codes to generate the system clock through external connections. If a crystal oscillator is used, a crystal or a ceramic resonator must be connected to XIN1 and XOUT1, and a capacitor must be connected if an accurate frequency is needed. When the oscillator is used, a high-frequency clock (400 KHz to 4 MHz) or low-frequency clock (32 KHz) can be selected for the system clock by means of option codes. If the RC oscillator is used, a resistor must be connected to XIN1 and XOUT1, and the high/low frequency clock option must be selected to suit the operation frequency. The sub-oscillator must be connected to a 32.768 KHz crystal through XIN2 and XOUT2 external pins when the dual-clock operation mode is selected by option code. The connection is shown in Figure 3. One machine cycle consists of a four-state system clock sequence and can run up to 1 μS with a 4 MHz system clock.

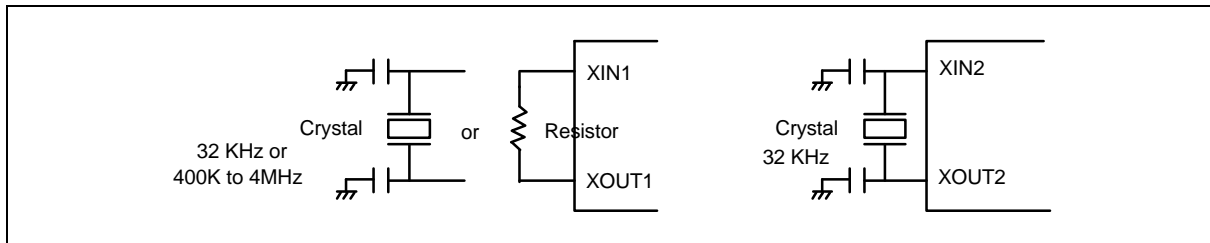

Figure 3. Oscillator Configuration

### Dual-clock operation

This operation mode is selected by code option. In the dual-clock mode, the clock source of the LCD frequency selector should be the sub-oscillator clock (32768 Hz) only. But in the single-clock mode, the clock source of the LCD frequency selector will be  $F_m$  or  $F_m/32$  ( $F_m$ : main oscillator clock).

In this dual-clock mode, the normal operation is performed by generating the system clock from the main-oscillator clock ( $F_m$ ). As required, the slow operation can be performed by generating the system clock from the sub-oscillator clock ( $F_s$ ). The exchange of the normal operation and the slow operation is performed by resetting or setting the bit 0 of the system clock control register (SCR). If the SCR.0 is reset to 0, the clock source of the system clock generator is the main-oscillator clock; if the SCR.0 is set to 1, the clock source of the system clock generator is the sub-oscillator clock. In dual-clock mode, the main-oscillator can stop oscillating when SCR.1 is set to 1. But in the single-clock mode, the main-oscillator can not be stop from oscillating because the SCR would be disabled in single-clock mode. Therefore, in single-clock mode, the clock source of the system clock generator is the main-oscillator clock ( $F_{osc} = F_m$ ).

When the SCR is set or reset, we must pay attention to the following:

1. X000B → X011B: Disable the main-oscillator ( $F_m$ ) should not be done simultaneously with changing the system clock source ( $F_{osc}$ ) from  $F_m$  to  $F_s$ . The  $F_{osc}$  should be changed first from  $F_m$  to  $F_s$  before the main-oscillator ( $F_m$ ) is disabled. The correct sequence is: X000B→X001B→X011B.
2. X011B → X000B: Enabling the main-oscillator ( $F_m$ ) should not be done simultaneously with changing the  $F_{osc}$  from  $F_s$  into  $F_m$ . The main-oscillator ( $F_m$ ) should be enabled first before a delay subroutine is called to allow the main-oscillator to oscillate stably. The  $F_{osc}$  can now be changed from  $F_s$  into  $F_m$ . The correct sequence is therefore X011B→X001B→delay subroutine→X000B. The suggested delay for  $F_m$  is 20 mS for 455 KHz ceramic resonator and 10 mS for 4 MHz crystal.

We must remember that the X010B state is inhibitive, because it will induce a system shutdown.

The organization of the dual-clock operation mode is shown below.

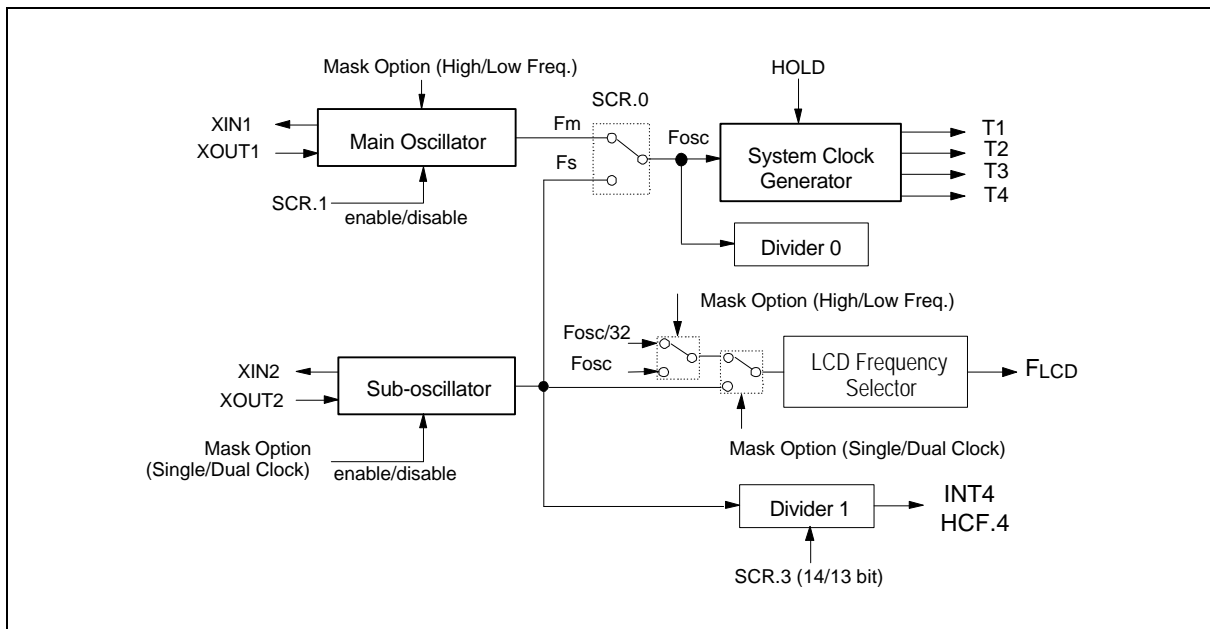

Figure 4. The Dual Clock Operation Mode Control Diagram

## Divider

Each divider is organized as a 14-bit binary up-counter designed to generate periodic interrupts. When the main oscillator starts action, the divider0 is incremented by each clock ( $F_{osc}$ ). When an overflow occurs, the divider0 event flag is set to 1 ( $EVF.0 = 1$ ). The interrupt is executed if the divider0 interrupt enable flag has been set ( $IEF.0 = 1$ ), and the hold state is terminated if the hold release enable flag has been set ( $HEF.0 = 1$ ). The last 4-stage of the divider0 can be reset by executing a CLR DIVR0 instruction. If the main oscillator is connected to the 32768 Hz crystal, the  $EVF.0$  will be set to 1 periodically at each 500 mS interval.

If the sub-oscillator is enabled, the divider1 is incremented by each clock ( $F_s$ ). When an overflow occurs, the divider1 event flag is set to 1 ( $EVF.4 = 1$ ). The interrupt is executed if the divider1 interrupt enable flag has been set ( $IEF.4 = 1$ ), and the hold state is terminated if the hold release enable flag has been set ( $HEF.4 = 1$ ). There are two time periods (250 mS & 500 mS) that can be selected by setting the SCR.3 bit. When  $SCR.3 = 0$  (default), the 500 mS period time is selected; when  $SCR.3 = 1$ , the 250 mS period time is selected.

## Watchdog Timer (WDT)

The watchdog timer (WDT) is organized as a 4-bit up counter and is designed to protect the program from unknown errors. The WDT is enabled when the corresponding option code bit of the WDT is set to 1. If the WDT overflows, the chip will be reset. At initial reset, the input clock of the WDT is  $F_{osc}/1024$ . The input clock of the WDT can be switched to  $F_{osc}/16384$  (or  $F_{osc}/1024$ ) by executing the SET PMF, #08H (or CLR PMF, #08H) instruction. The contents of the WDT can be reset by the instruction CLR WDT. In normal operation, the application program must reset WDT before it overflows. A WDT overflow indicates that the operation is not under control and the chip will be reset. The WDT minimum overflow period is 468.75 mS when the system clock ( $F_{osc}$ ) is 32 KHz and WDT clock input is  $F_{osc}/1024$ . When the corresponding option code bit of the WDT is set to 0, and the WDT function is disabled. The organization of the Divider0 and watchdog timer is shown in Figure 4.

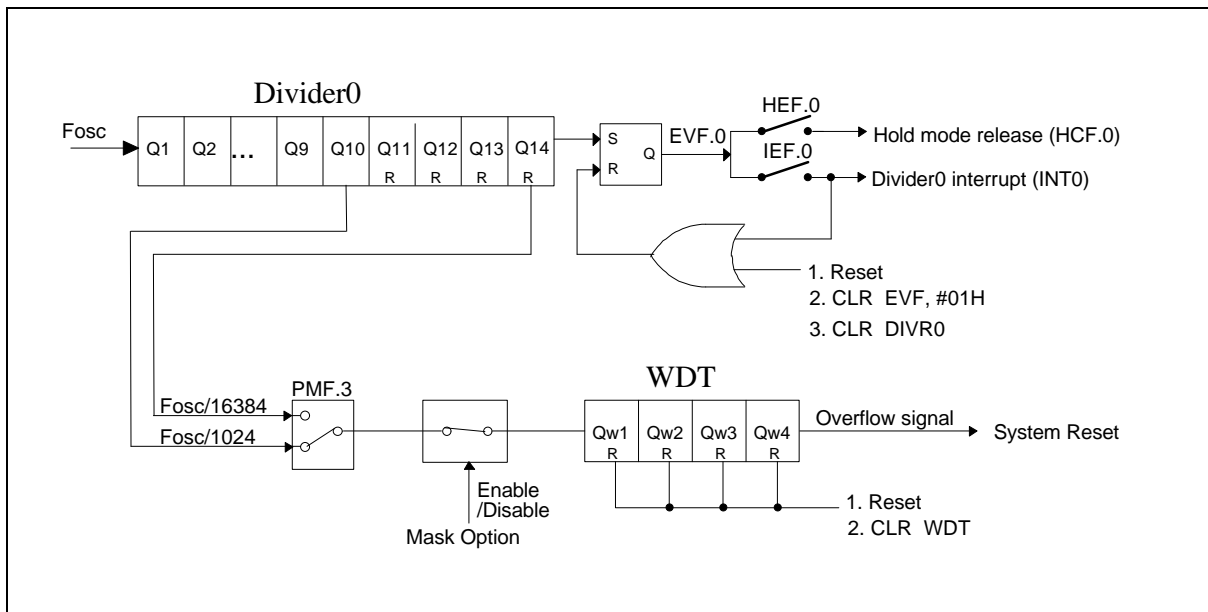

Figure 4. Organization of Divider 0 and Watchdog Timer

## Timer/Counter

### 1. Timer 0 (TM0)

Timer 0 (TM0) is a programmable 8-bit binary down-counter. The specified value can be loaded into TM0 by executing the MOV TM0L (TM0H), R or MOV TM0, #I instructions. When the MOV TM0L (TM0H), R instructions are executed, the TM0 will stop down-counting (if the TM0 is down-counting), the MR0.3 will be reset to 0, and the specified value is loaded into TM0. If MR0.3 is set to 1, the event flag 1 (EVF.1) is reset and the TM0 starts to count. When it decrements to FFH, Timer 0 stops operating and generates an underflow (EVF.1 = 1). The interrupt is executed if the Timer 0 interrupt enable flag has been set (IEF.1 = 1); and the hold state is terminated if the hold release enable flag 1 has been set (HEF.1 = 1). The Timer 0 clock input can be set as Fosc/1024 or Fosc/4 by setting MR0.0 to 1 or by resetting MR0.0 to 0. The default timer value is Fosc/4. The organization of Timer 0 is shown in Figure 5.

If the Timer 0 clock input is Fosc/4, then:

$$\text{Desired Time 0 interval} = (\text{preset value} + 1) \times 4 \times 1/\text{Fosc}$$

If the Timer 0 clock input is Fosc/1024, then:

$$\text{Desired Time 0 interval} = (\text{preset value} + 1) \times 1024 \times 1/\text{Fosc}$$

Preset value: Decimal number of Timer 0 preset value

Fosc: Clock oscillation frequency

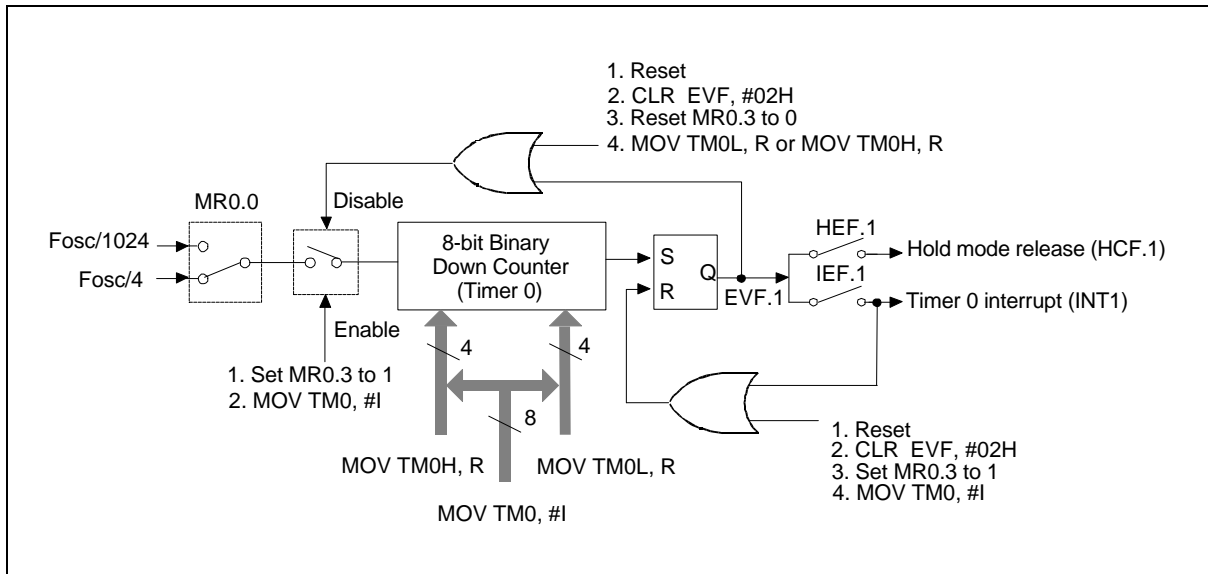

Figure 5. Organization of Timer 0

## 2. Timer 1 (TM1)

Timer 1 (TM1) is also a programmable 8-bit binary down counter, as shown in Figure 6. Timer 1 can be used as a counter to count external events or to output an arbitrary frequency to the MFP pin. The input clock of Timer 1 can be one of three sources: Fosc/64, Fosc, or an external clock from the RC.0 input pin. The source can be selected by setting bit 0 and bit 1 of mode register 1 (MR1). At initial reset, the Timer 1 clock input is Fosc. If an external clock is selected as the clock source of Timer 1, the content of Timer 1 is decreased by 1 at the falling edge of RC.0. When the MOV TM1L, R or MOV TM1H, R instruction is executed, the specified data are loaded into the auto-reload buffer and the TM1 down-counting will be disabled (i.e. MR1.3 is reset to 0). If the bit 3 of MR1 is set (MR1.3 = 1), the contents of the auto-reload buffer will be loaded into the TM1 down counter, Timer 1 starts to down count, and the event flag 7 is reset (EVF.7 = 0). When the MOV TM1, #I instruction is executed, the event flag 7 (EVF.7) and MR1.3 are reset and the specified value is loaded into auto-reload buffer and TM1 by the internal hardware, then the MR1.3 is set, that is the TM1 starts to count by the hardware. When the timer decrements to FFH, it will generate an underflow (EVF.7 = 1) and be auto-reloaded with the specified data, after which it will continue to count down. An interrupt is executed if the interrupt enable flag 7 has been set to 1 (IEF.7 = 1), and the hold state is terminated if the hold mode release enable flag 7 is set to 1 (HEF.7 = 1). The specified frequency of Timer 1 can be delivered to the MFP output pin by programming bit 2 of MR1. Bit 3 of MR1 can be used to make Timer 1 stop or start counting.

If the Timer 1 clock input is FT, then:

Desired Timer 1 interval = (preset value + 1) / FT

Desired frequency for MFP output pin = FT ÷ (preset value + 1) ÷ 2 (Hz)

Preset value: Decimal number of Timer 1 preset value, and

Fosc: Clock oscillation frequency

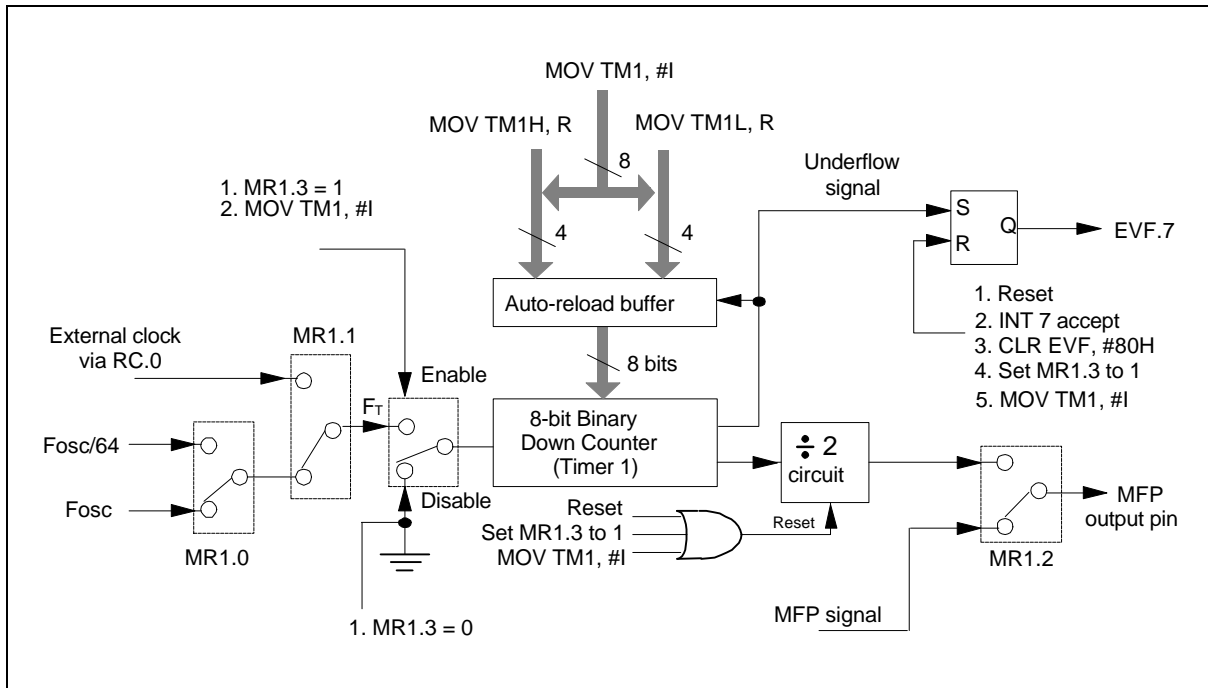

Figure 6. Organization of Timer 1

For example, when Ft equals 32768 Hz, depending on the preset value of TM1, the MFP pin will output a single tone signal in the tone frequency range from 64 Hz to 16384 Hz. The relation between the tone frequency and the preset value of TM1 is shown in the table below.

		3			4			5		
		Tone frequency	TM1 preset value & MFP frequency		Tone frequency	TM1 preset value & MFP frequency		Tone frequency	TM1 preset value & MFP frequency	
T	C	130.81	7CH	131.07	261.63	3EH	260.06	523.25	1EH	528.51
	C#	138.59	75H	138.84	277.18	3AH	277.69	554.37	1CH	564.96
	D	146.83	6FH	146.28	293.66	37H	292.57	587.33	1BH	585.14
	D#	155.56	68H	156.03	311.13	34H	309.13	622.25	19H	630.15
O	E	164.81	62H	165.49	329.63	31H	327.68	659.26	18H	655.36
	F	174.61	5DH	174.30	349.23	2EH	372.36	698.46	16H	712.34
N	F#	185.00	58H	184.09	369.99	2BH	390.09	739.99	15H	744.72
	G	196.00	53H	195.04	392.00	29H	420.10	783.99	14H	780.19
E	G#	207.65	4EH	207.39	415.30	26H	443.81	830.61	13H	819.20
	A	220.00	49H	221.40	<b>440.00</b>	<b>24H</b>	<b>442.81</b>	880.00	12H	862.84
	A#	233.08	45H	234.05	466.16	22H	468.11	932.23	11H	910.22
	B	246.94	41H	248.24	493.88	20H	496.48	987.77	10H	963.76

Note: Central tone is A4 (440 Hz).

## Mode Register 0 (MR0)

Mode Register 0 is organized as a 4-bit binary register (MR0.0 to MR0.3). MR0 can be used to control the operation of Timer 0. The bit descriptions are as follows:

	3	2	1	0
MR0	W	-	-	W

Note: W means write only.

Bit 0 = 0 The internal fundamental frequency of Timer 0 is  $F_{osc}/4$ .

= 1 The internal fundamental frequency of Timer 0 is  $F_{osc}/1024$ .

Bit 1 Reserved

Bit 2 Reserved

Bit 3 = 0 Timer 0 stops down-counting.

= 1 Timer 0 starts down-counting.

## Mode Register 1 (MR1)

Mode Register 1 is organized as a 4-bit binary register (MR1.0 to MR1.3). MR1 can be used to control the operation of Timer 1. The bit descriptions are as follows:

	3	2	1	0
MR1	W	W	W	W

Note: W means write only.

Bit 0 = 0 The internal fundamental frequency of Timer 1 is  $F_{osc}$ .

= 1 The internal fundamental frequency of Timer 1 is  $F_{osc}/64$ .

Bit 1 = 0 The fundamental frequency source of Timer 1 is the internal clock.

= 1 The fundamental frequency source of Timer 1 is the external clock from RC.0 input pin.

Bit 2 = 0 The specified waveform of the MFP generator is delivered at the MFP output pin.

= 1 The specified frequency of Timer 1 is delivered at the MFP output pin.

Bit 3 = 0 Timer 1 stops down-counting.

= 1 Timer 1 starts down-counting.

**Interrupts**

The W741C260 provides four internal interrupt sources (Divider 0, Divider 1, Timer 0, Timer 1) and one external interrupt source (port RC). Vector addresses for each of the interrupts are located in the range of program memory (ROM) addresses 004H to 020H. The flags IEF, PEF, and EVF are used to control the interrupts. When EVF is set to "1" by hardware and the corresponding bits of IEF and PEF have been set by software, an interrupt is generated. When an interrupt occurs, all of the interrupts are inhibited until the EN INT or MOV IEF,#I instruction is invoked. The interrupts can also be disabled by executing the DIS INT instruction. When an interrupt is generated in hold mode, the hold mode will be released momentarily and interrupt subroutine will be executed. After the RTN instruction is executed in an interrupt subroutine, the  $\mu$ C will enter hold mode again. The operation flow chart is shown in Figure 8. The control diagram is shown below.

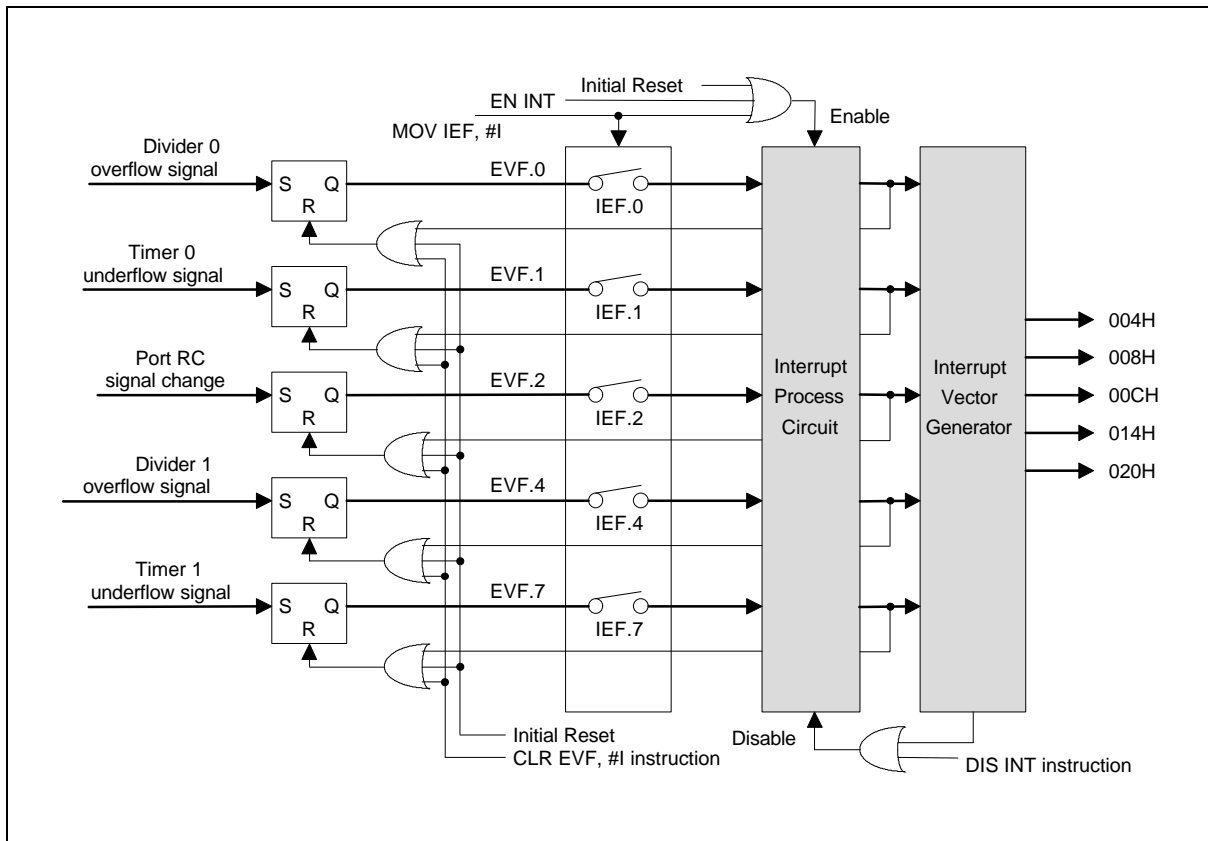

Figure 7. Interrupt Event Control Diagram

**Interrupt Enable Flag (IEF)**

The interrupt enable flag is organized as an 8-bit binary register (IEF.0 to IEF.7). These bits are used to control the interrupt conditions. It is controlled by the MOV IEF, #I instruction. When one of these interrupts is accepted, the corresponding to the bit of the event flag will be reset, but the other bits are unaffected. In interrupt subroutine, these interrupts will be disabled till the instruction MOV IEF, #I or EN INT is executed again. Therefore, to enable these interrupts, the instructions MOV IEF, #I or EN INT is executed again.



INT must be executed again. Otherwise, these interrupts can be disabled by executing DIS INT instruction. The bit descriptions are as follows:

	7	6	5	4	3	2	1	0
IEF	w	-	-	w	-	w	w	w

Note: W means write only.

IEF.0 = 1 Interrupt 0 is accepted by overflow from the Divider 0.

IEF.1 = 1 Interrupt 1 is accepted by underflow from the Timer 0.

IEF.2 = 1 Interrupt 2 is accepted by a signal change on port RC.

IEF.3 Reserved

IEF.4 = 1 Interrupt 0 is accepted by overflow from the Divider 1.

IEF.5 & IEF.6 are reserved.

IEF.7 = 1 Interrupt 7 is accepted by underflow from Timer 1.

## Stop Mode Operation

In stop mode, all operations of the  $\mu$ C cease (excluding the operation of sub-oscillator and divider 1 when the dual-clock operation mode is selected). The  $\mu$ C enters stop mode when the STOP instruction is executed and exits stop mode when an external trigger is activated (by a falling signal on the RC port). When the designated signal is accepted, the  $\mu$ C awakens and executes the next instruction (if the corresponding bits of IEF and PEF have been set, It will enter the interrupt service routine after stop mode released). To prevent erroneous execution, the NOP instruction should follow the STOP command.

## Stop Mode Wake-up Enable Flag for Port RC (SEF)

The stop mode wake-up flag for port RC is organized as a 4-bit binary register (SEF.0 to SEF.3). Before port RC may be used to make the device exit the stop mode, the content of the SEF must be set first. The SEF is controlled by the MOV SEF, #I instruction. The bit descriptions are as follows:

	3	2	1	0
SEF	w	w	w	w

Note: W means write only.

SEF 0 = 1 Device will exit stop mode when falling edge signal is applied to pin RC.0.

SEF 1 = 1 Device will exit stop mode when falling edge signal is applied to pin RC.1.

SEF 2 = 1 Device will exit stop mode when falling edge signal is applied to pin RC.2.

SEF 3 = 1 Device will exit stop mode when falling edge signal is applied to pin RC.3.

### Hold Mode Operation

In hold mode, all operations of the  $\mu$ C cease, except for the operation of the oscillator, timer, divider and LCD driver. The  $\mu$ C enters hold mode when the HOLD instruction is executed. The hold mode can be released in one of five ways: by the action of timer 0, timer 1, divider 0, divider 1 or the RC port. Before the device enters the hold mode, the HEF, PEF, and IEF flags must be set to define the hold mode release conditions. For more details, refer to the instruction-set table and the following flow chart.

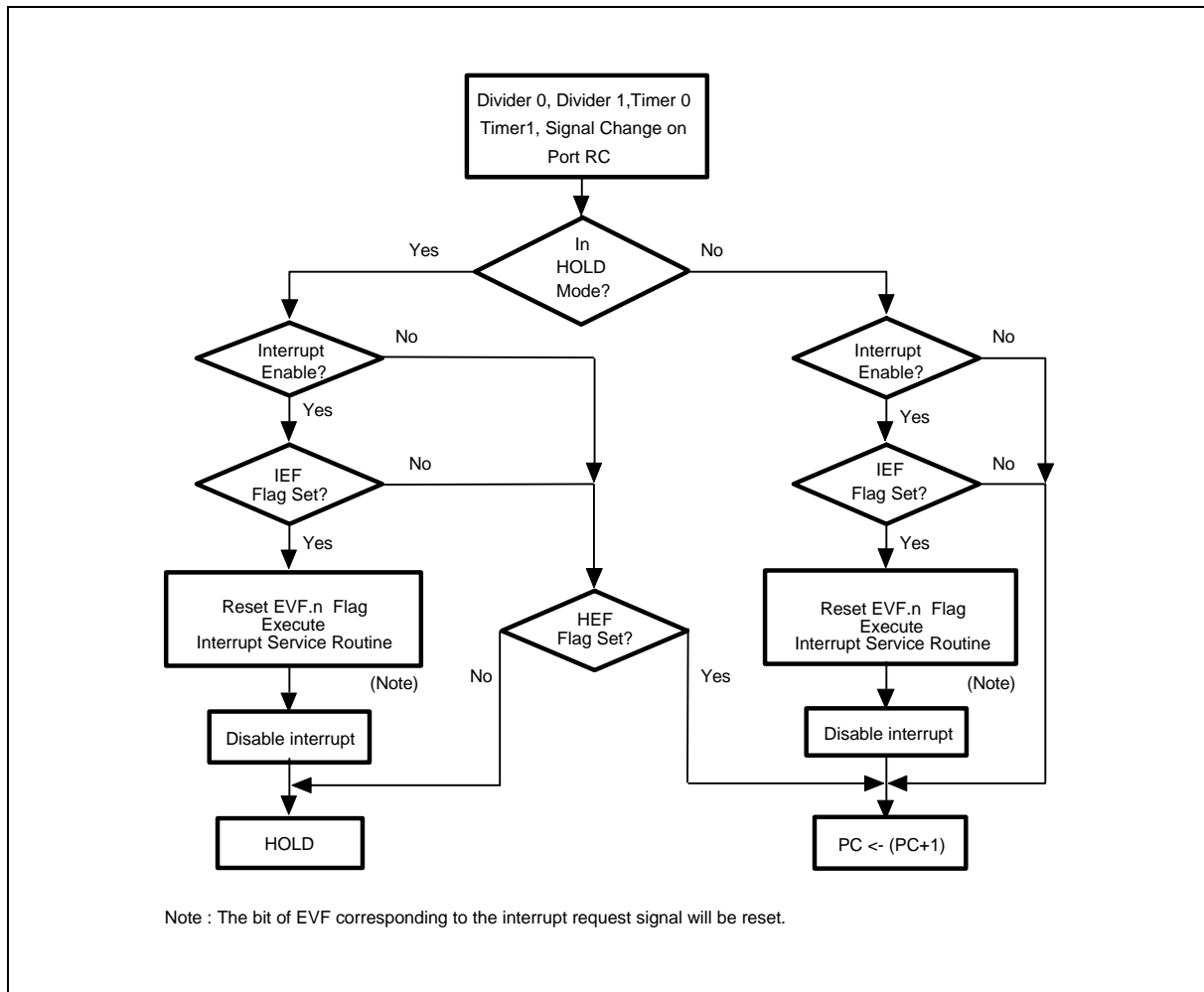

Figure 8. Hold Mode and Interrupt Operation Flow Chart



## Hold Mode Release Enable Flag (HEF)

The hold mode release enable flag is organized as an 8-bit binary register (HEF.0 to HEF.7). The HEF is used to control the hold mode release conditions. It is controlled by the MOV HEF, #I instruction. The bit descriptions are as follows:

	7	6	5	4	3	2	1	0
HEF	w	—	—	w	—	w	w	w

Note: W means write only.

HEF.0 = 1 Overflow from the Divider 0 causes hold mode to be released.

HEF.1 = 1 Underflow from Timer 0 causes hold mode to be released.

HEF.2 = 1 Signal change on port RC causes hold mode to be released.

HEF.3 Reserved

HEF.4 = 1 Overflow from the Divider 1 causes hold mode to be released.

HEF.5 & HEF.6 are reserved.

HEF.7 = 1 Underflow from Timer 1 causes hold mode to be released.

## Port Enable Flag (PEF)

The port enable flag is organized as 4-bit binary register (PEF.0 to PEF.3). Before port RC may be used to release the hold mode or preform interrupt function, the content of the PEF must be set first. The PEF is controlled by the MOV PEF, #I instruction. The bit descriptions are as follows:

	3	2	1	0
PEF	w	w	w	w

Note: W means write only.

PEF.0: Enable/disable the signal change on pin RC.0 to release hold mode or perform interrupt.

PEF.1: Enable/disable the signal change on pin RC.1 to release hold mode or perform interrupt.

PEF.2: Enable/disable the signal change on pin RC.2 to release hold mode or perform interrupt.

PEF.3: Enable/disable the signal change on pin RC.3 to release hold mode or perform interrupt.

## Hold Mode Release Condition Flag (HCF)

The hold mode release condition flag is organized as a 8-bit binary register (HCF0 to HCF7). It indicates by which interrupt source the hold mode has been released, and is loaded by hardware. The HCF can be read out by the MOVA R, HCFL and MOVA R, HCFH instructions. When any of the HCF bits is "1," the hold mode will be released and the HOLD instruction is invalid. The HCF can be reset by the CLR EVF,#I (EVF.n = 0) or MOV HEF,#I (HEF.n = 0) instructions. When EVF or HEF have been reset, the corresponding bit of HCF is reset simultaneously. The bit descriptions are as follows:

	7	6	5	4	3	2	1	0
HCF	—	—	R	R	—	R	R	R

Note: R means read only.



HCF.0 = 1 Hold mode was released by overflow from the Divider0.  
 HCF.1 = 1 Hold mode was released by underflow from the Timer 0.  
 HCF.2 = 1 Hold mode was released by a signal change on port RC  
 HCF.3     Reservsd  
 HCF.4 = 1 Hold mode was released by overflow from the Divider 1.  
 HCF.5 = 1 Hold mode was released by underflow from the Timer 1.  
 HCF.6 & HCF.7 are reserved.

### Event Flag (EVF)

The event flag is organized as an 8-bit binary register (EVF0 to EVF7). It is set by hardware and reset by CLR EVF, #I instruction or the occurrence of an interrupt. The bit descriptions are as follows:

	7	6	5	4	3	2	1	0
EVF	R	-	-	R	-	R	R	R

Note: R means read only.

EVF.0 = 1 Overflow from Divider 0 occurred.  
 EVF.1 = 1 Underflow from Timer 0 occurred.  
 EVF.2 = 1 Signal change on port RC occurred.  
 EVF.3     Reserved  
 EVF.4 = 1 Overflow from Divider 1 occurred.  
 EVF.5 & EVF.6 are reserved.  
 EVF.7 = 1 Underflow from Timer 1 occurred.

### Parameter Flag (PMF)

The parameter flag is organized as a 4-bit binary register (PMF.0 to PMF.3). The PMF is controlled by the SET PMF, #I or CLR PMF, #I instruction. The bit descriptions are as follows:

	3	2	1	0
PMF	W	-	-	-

Note: W means write only.

Bit 0, Bit1, Bit2             Reserved  
 Bit 3 = 0 The fundamental frequency of the watchdog timer is Fosc/1024.  
       = 1 The fundamental frequency of the watchdog timer is Fosc/16384.

### Port Mode 0 Register (PM0)

The port mode 0 register is organized as a 4-bit binary register (PM0.0 to PM0.3). PM0 can be used to determine the structure of the input/output ports; it is controlled by the MOV PM0, #I instruction. The bit descriptions are as follows:

	3	2	1	0
PM0	w	w	w	w

Note: W means write only.

Bit 0 = 0 RA port is CMOS output type. Bit 0 = 1 RA port is NMOS open drain output type.

Bit 1 = 0 RB port is CMOS output type. Bit 0 = 1 RB port is NMOS open drain output type.

Bit 2 = 0 RC port pull-high resistor is disabled.

= 1 RC port pull-high resistor is enabled.

Bit 3 = 0 RD port pull-high resistor is disabled.

= 1 RD port pull-high resistor is enabled.

### Port Mode 1 Register (PM1)

The port mode 1 register is organized as a 4-bit binary register (PM1.0 to PM1.3). PM1 can be used to control the input/output mode of port RA. PM1 is controlled by the MOV PM1, #I instruction. The bit descriptions are as follows:

	3	2	1	0
PM1	w	w	w	w

Note: W means write only.

Bit 0 = 0 RA.0 works as output pin; Bit 0 = 1 RA.0 works as input pin

Bit 1 = 0 RA.1 works as output pin; Bit 1 = 1 RA.1 works as input pin

Bit 2 = 0 RA.2 works as output pin; Bit 2 = 1 RA.2 works as input pin

Bit 3 = 0 RA.3 works as output pin; Bit 3 = 1 RA.3 works as input pin

At initial reset, port RA is input mode (PM1 = 1111B).

### Port Mode 2 Register (PM2)

The port mode 2 register is organized as a 4-bit binary register (PM2.0 to PM2.3). PM2 can be used to control the input/output mode of port RB. PM2 is controlled by the MOV PM2, #I instruction. The bit descriptions are as follows:

	3	2	1	0
PM2	w	w	w	w

Note: W means write only.

Bit 0 = 0 RB.0 works as output pin; Bit 0 = 1 RB.0 works as input pin



Bit 1 = 0 RB.1 works as output pin; Bit 1 = 1 RB.1 works as input pin  
Bit 2 = 0 RB.2 works as output pin; Bit 2 = 1 RB.2 works as input pin  
Bit 3 = 0 RB.3 works as output pin; Bit 3 = 1 RB.3 works as input pin  
At initial reset, the port RB is input mode (PM2 = 1111B).

## Reset Function

The W741C260 is reset either by a power-on reset or by using the external  $\overline{\text{RES}}$  pin. The initial state of the W741C260 after the reset function is executed is described below.

Program Counter (PC)	000H
TM0, TM1	Reset
MR0, MR1, PM0, PAGE, PMF registers	Reset
PM1, PM2 registers	Set (1111B)
PSR0 register	Reset
IEF, HEF, PEF, SEF, HCF, EVF flags	Reset
Timer 0 input clock	Fosc/4
Timer 1 input clock	Fosc
MFP output	Low
Input/output ports RA, RB	Input mode
Output port RE	High
RA & RB ports output type	CMOS type
RC & RD ports pull-high resistors	Disable
Input clock of the watchdog timer	Fosc/1024
LCD display	OFF
Segment output mode	LCD drive output



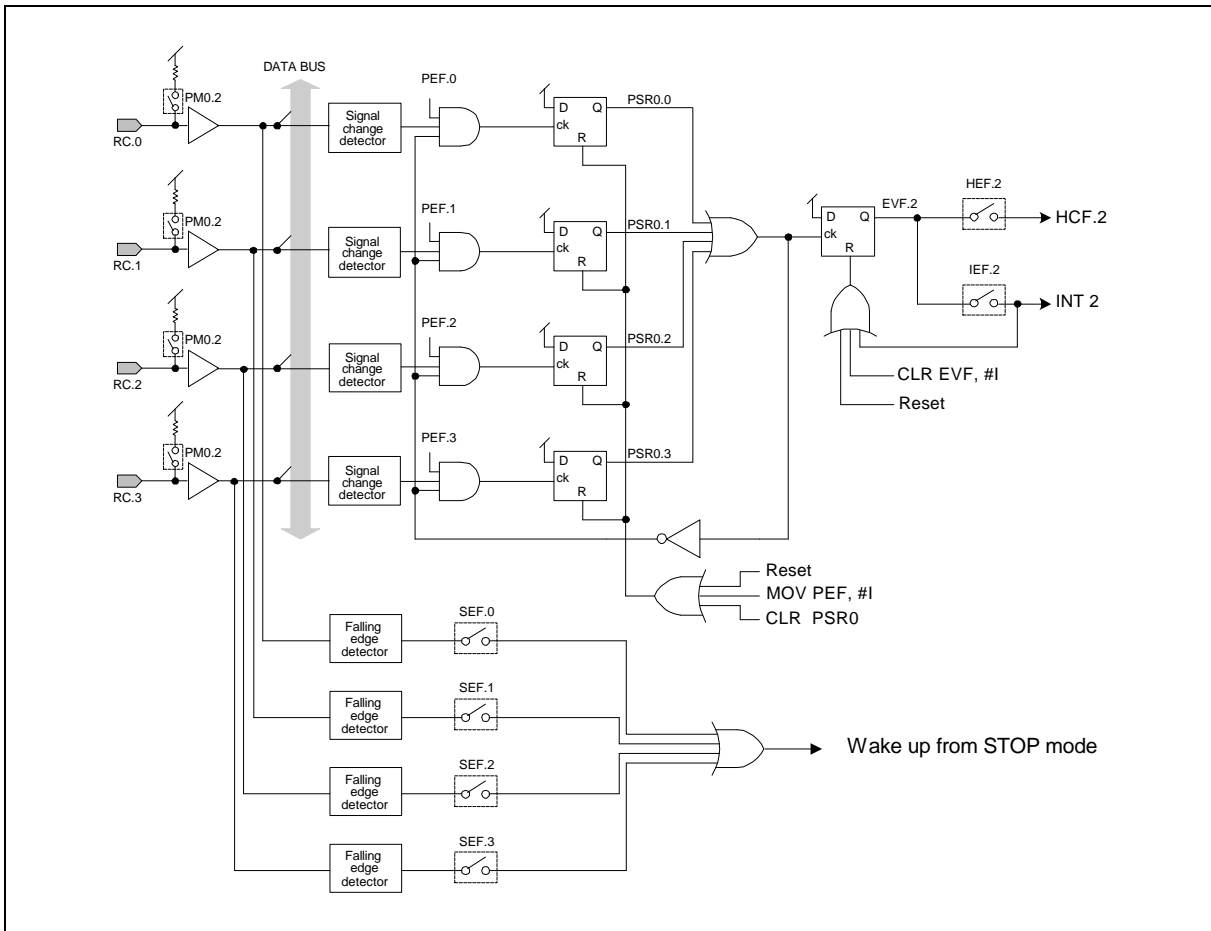

Figure 10. Architecture of Input Ports RC

**Output Port RE**

When the MOV RE, R instruction is executed, the data in the RAM will be output to port RE and it provides a high sink current to drive LEDs.

**Port Status Register 0 (PSR0)**

Port status register 0 is organized as 4-bit binary register (PSR0.0 to PSR0.3). PSR0 can be read or cleared by the MOVA R, PSR0, and CLR PSR0 instructions. The bit descriptions are as follows:

	3	2	1	0
PSR0	R	R	R	R

Note: R means read only.

- Bit 0 = 1 Signal change on RC.0
- Bit 1 = 1 Signal change on RC.1
- Bit 2 = 1 Signal change on RC.2
- Bit 3 = 1 Signal change on RC.3



## MFP Output Pin (MFP)

The MFP output pin can output the Timer 1 clock or the modulation frequency; the output of the pin is determined by mode register 1 (MR1). The organization of MR1 is shown in Figure 6. When bit 2 of MR1 is reset to "0," the MFP output can deliver a modulation output in any combination of one signal from among DC, 4096 Hz, 2048 Hz, and one or more signals from among 128 Hz, 64 Hz, 8 Hz, 4 Hz, 2 Hz, or 1 Hz (when using a 32.768 KHz system clock). The MOV MFP, #I instruction is used to specify the modulation output combination. The data specified by the 8-bit operand and the MFP output pin are shown as below:

(Fosc = 32.768 KHz)

R7 R6	R5	R4	R3	R2	R1	R0	FUNCTION
0 0	0	0	0	0	0	0	Low level
	0	0	0	0	0	1	128 Hz
	0	0	0	0	1	0	64 Hz
	0	0	0	1	0	0	8 Hz
	0	0	1	0	0	0	4 Hz
	0	1	0	0	0	0	2 Hz
	1	0	0	0	0	0	1 Hz
0 1	0	0	0	0	0	0	High level
	0	0	0	0	0	1	128 Hz
	0	0	0	0	1	0	64 Hz
	0	0	0	1	0	0	8 Hz
	0	0	1	0	0	0	4 Hz
	0	1	0	0	0	0	2 Hz
	1	0	0	0	0	0	1 Hz
1 0	0	0	0	0	0	0	2048 Hz
	0	0	0	0	0	1	2048 Hz * 128 Hz
	0	0	0	0	1	0	2048 Hz * 64 Hz
	0	0	0	1	0	0	2048 Hz * 8 Hz
	0	0	1	0	0	0	2048 Hz * 4 Hz
	0	1	0	0	0	0	2048 Hz * 2 Hz
	1	0	0	0	0	0	2048 Hz * 1 Hz
1 1	0	0	0	0	0	0	4096 Hz
	0	0	0	0	0	1	4096 Hz * 128 Hz
	0	0	0	0	1	0	4096 Hz * 64 Hz
	0	0	0	1	0	0	4096 Hz * 8 Hz
	0	0	1	0	0	0	4096 Hz * 4 Hz
	0	1	0	0	0	0	4096 Hz * 2 Hz
	1	0	0	0	0	0	4096 Hz * 1 Hz

**LCD Controller/Driver**

The W741C260 can directly drive an LCD with 32 segment output pins and 4 common output pins for a total of  $32 \times 4$  dots. Option codes can be used to select one of five options for the LCD driving mode: static, 1/2 bias 1/2 duty, 1/2 bias 1/3 duty, 1/3 bias 1/3 duty, or 1/3 bias 1/4 duty (see Figure 12). The alternating frequency of the LCD can be set as  $F_w/64$ ,  $F_w/128$ ,  $F_w/256$ , or  $F_w/512$ . In addition, option codes can also be used to set up four of the LCD driver output pins (segment 0 to segment 31) as a DC output port. The structure of the LCD alternating frequency (FLCD) is shown in the figure below.

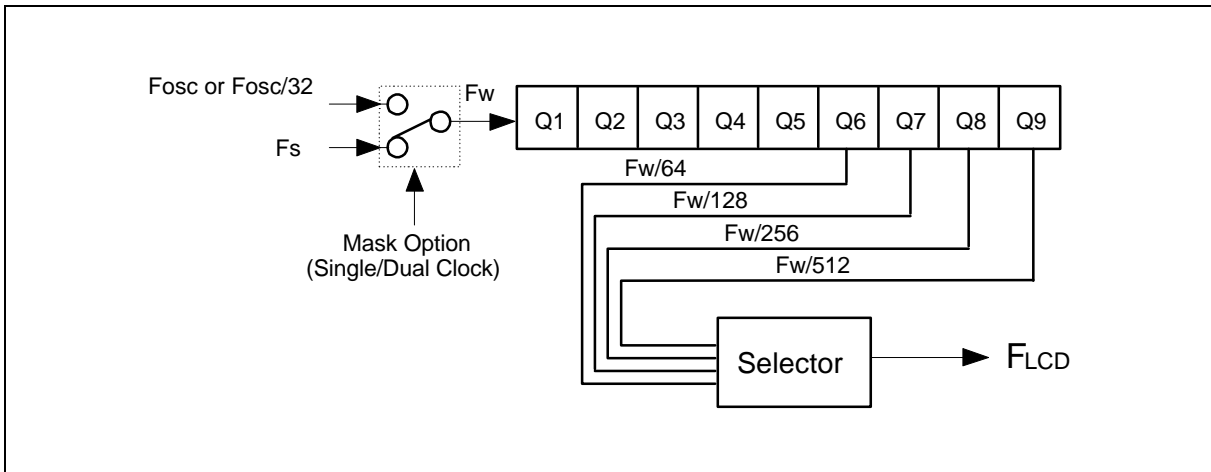

Figure 11. LCD Alternating Frequency (FLCD) Circuit Diagram

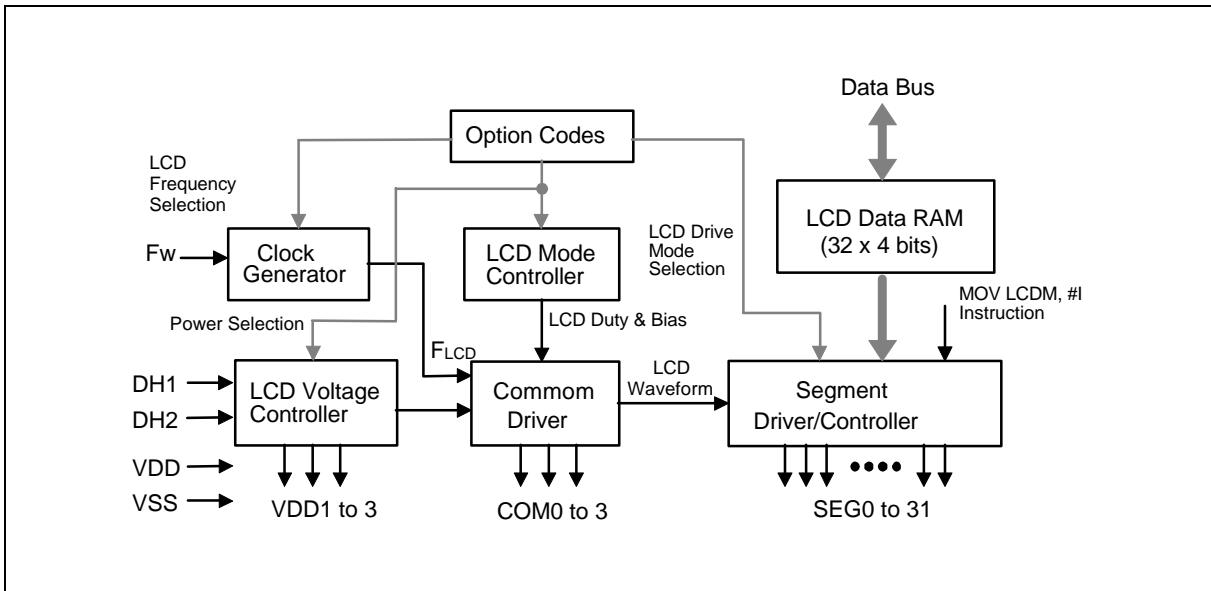

Figure 12. LCD Driver/Controller Circuit Diagram



When  $F_w = 32.768$  KHz, the LCD frequency is as shown in the table below.

LCD FREQUENCY	STATIC	1/2 DUTY	1/3 DUTY	1/4 DUTY
Fw/512 (64 Hz)	64	32	21	16
Fw/256 (128 Hz)	128	64	43	32
Fw/128 (256 Hz)	256	128	85	64
Fw/64 (512 Hz)	512	256	171	128

Corresponding to the 32 LCD drive output pins, there are 32 LCD data RAM segments (LCDR00 to LCDR1F). Instructions such as MOV LCDR, #I; MOV WR, LCDR; MOV LCDR, WR; and MOV LCDR, ACC are used to control the LCD data RAM. The data in the LCD data RAM are transferred to the segment output pins automatically without program control. When the bit value of the LCD data RAM is "1," the LCD is turned on. When the bit value of the LCD data RAM is "0," LCD is turned off. The contents of the LCD data RAM (LCDR) are sent out through the segment 0 to segment 31 pins by a direct memory access. The relationship between the LCD data RAM and segment/common pins is shown below.

		COM3	COM2	COM1	COM0
LCD data RAM	Output pin	bit 3	bit 2	bit 1	bit 0
LCDR00	SEG0	0/1	0/1	0/1	0/1
LCDR01	SEG1	0/1	0/1	0/1	0/1
.	.	.	.	.	.
LCDR1E	SEG30	0/1	0/1	0/1	0/1
LCDR1F	SEG31	0/1	0/1	0/1	0/1

The LCDON instruction turns the LCD display on (even in HOLD mode), and the LCDOFF instruction turns the LCD display off. At initial reset, all the LCD segments are lit. When the initial reset state ends, the LCD display is turned off automatically. To turn on the LCD display, the instruction LCDON must be executed. When the drive output pins are used as DC output ports (set by option codes, please refer the user's manual of ASM741S assembler for more detail), CMOS output type or NMOS output type can be selected by executing the instruction MOV LCDM, #I. The relation between the LCD data RAM and segment/common pins is shown below. The data in LCDR00 are transferred to the corresponding segment output port (SEG3 to SEG0) by a direct memory access. The other LCD data RAM segments can be used as normal data RAM to store data.

LCD DATA RAM	OUTPUT PIN	BIT 3	BIT 2	BIT 1	BIT 0
LCDR00	SEG3-SEG0	SEG3	SEG2	SEG1	SEG0
LCDR03-LCDR01	-	-	-	-	-
LCDR04	SEG7-SEG4	SEG7	SEG6	SEG5	SEG4
LCDR07-LCDR05	-	-	-	-	-



Continued

·	·	·	·	·	·
·	·	·	·	·	·
·	·	·	·	·	·
LCDR1C	SEG31–SEG28	SEG31	SEG30	SEG29	SEG28
LCDR1F–LCDR1D	-	-	-	-	-

The relationship between the LCD drive mode and the maximum number of drivable LCD segments is shown below.

LCD DRIVE MODE	MAX. NUMBER OF DRIVABLE LCD SEGMENT	CONNECTION AT POWER INPUT
Static	32 (COM1)	Connect VDD3, VDD2 to VDD1
1/2 Bias 1/2 Duty	64 (COM1–COM2)	Connect VDD3 to VDD2
1/2 Bias 1/3 Duty	96 (COM1–COM3)	Connect VDD3 to VDD2
1/3 Bias 1/3 Duty	96 (COM1–COM3)	-
1/3 Bias 1/4 Duty	128 (COM1–COM4)	-

### LCD Output Mode Type Flag (LCDM)

The LCD output mode type flag is organized as an 8-bit binary register (LCDM.0 to LCDM.7). These bits are used to control the LCD output pins architecture. When LCD output pins are set to DC output mode by option codes, the architecture of these output pins (segment 0 to segment 31) can be selected as CMOS or NMOS type. It is controlled by the MOV LCDM, #1 instruction. The bit descriptions are as follows:

	7	6	5	4	3	2	1	0
LCDM	w	w	w	w	w	w	w	w

Note: W means write only.

LCDM.0 = 0 SEG0 to SEG3 work as CMOS output type.

= 1 SEG0 to SEG3 work as NMOS output type.

LCDM.1 = 0 SEG4 to SEG7 work as CMOS output type.

= 1 SEG4 to SEG7 work as NMOS output type.

LCDM.2 = 0 SEG8 to SEG11 work as CMOS output type.

= 1 SEG8 to SEG11 work as NMOS output type.

LCDM.3 = 0 SEG12 to SEG15 work as CMOS output type.

= 1 SEG12 to SEG15 work as NMOS output type.

LCDM.4 = 0 SEG16 to SEG19 work as CMOS output type.

= 1 SEG16 to SEG19 work as NMOS output type.

LCDM.5 = 0 SEG20 to SEG23 work as CMOS output type.

= 1 SEG20 to SEG23 work as NMOS output type.



LCDM.6 = 0 SEG24 to SEG27 work as CMOS output type.  
 = 1 SEG24 to SEG27 work as NMOS output type.  
 LCDM.7 = 0 SEG28 to SEG31 work as CMOS output type.  
 = 1 SEG28 to SEG31 work as NMOS output type.

The output waveforms for the five LCD driving modes are shown below.

**Static Lighting System (Example)**

**Normal Operating Mode**

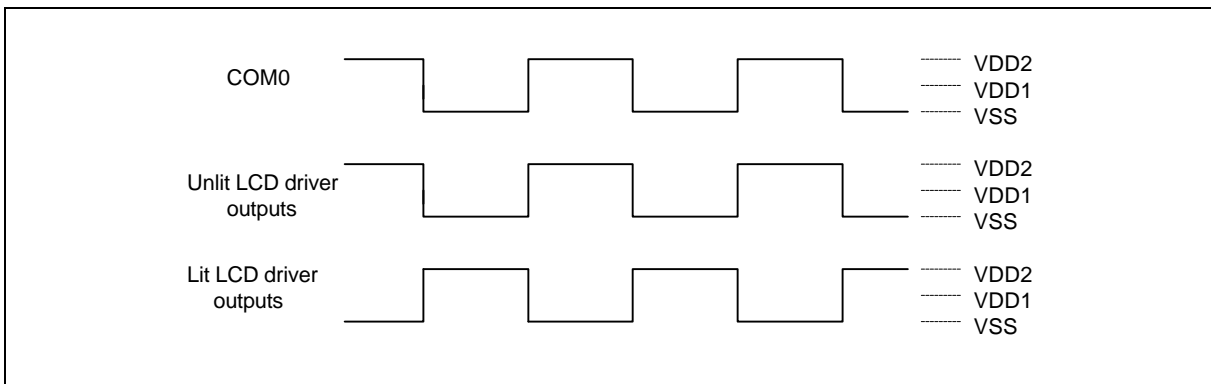

**1/2 Bias 1/2 Duty Lighting System (Example)**

**Normal Operating Mode**

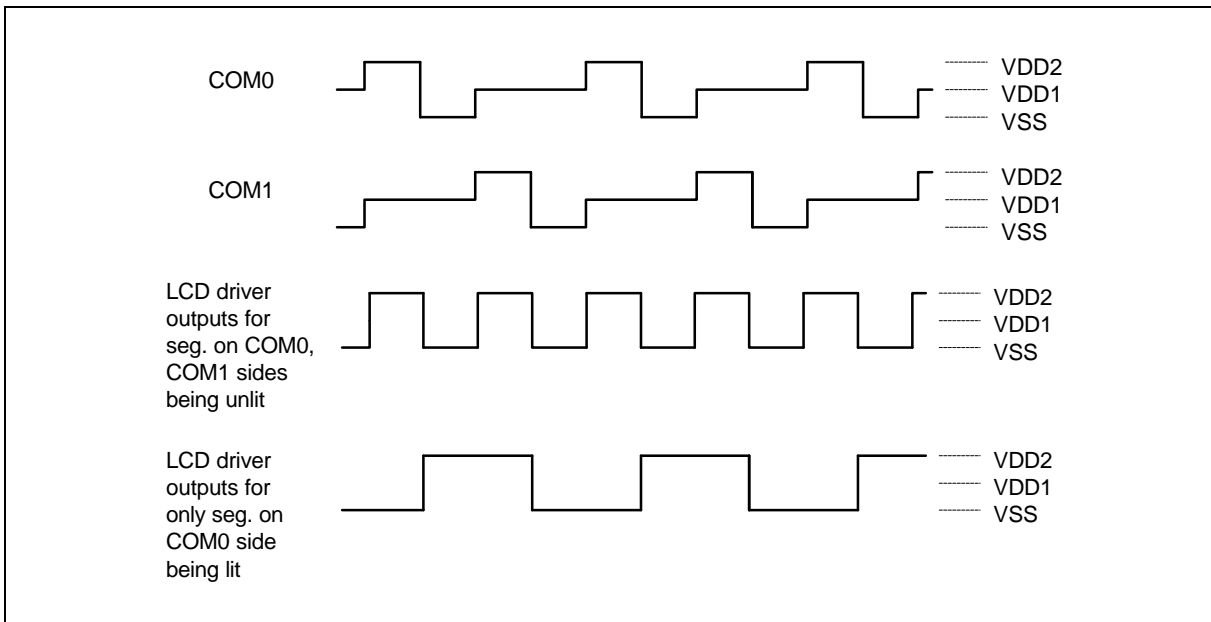



1/2 Bias 1/2 Duty Lighting System (Example)- Normal Operating Mode, continued

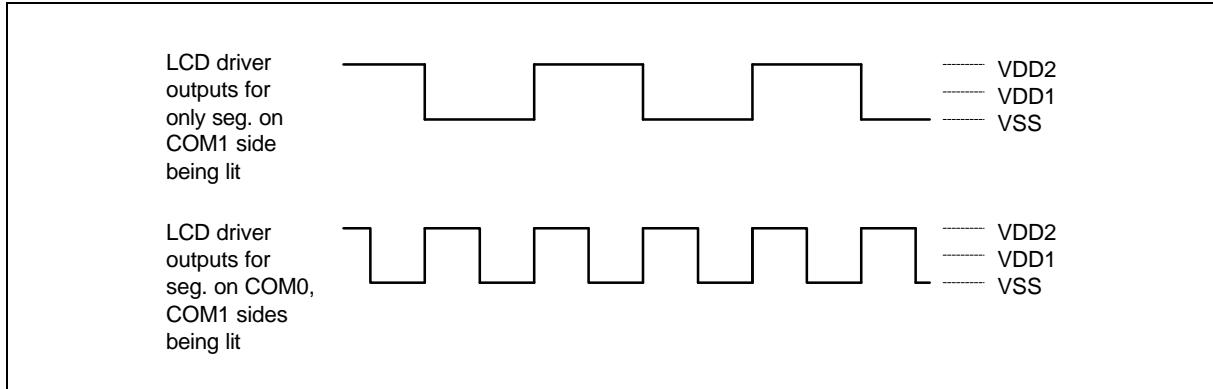

1/2 Bias 1/3 Duty Lighting System (Example)

Normal Operating Mode

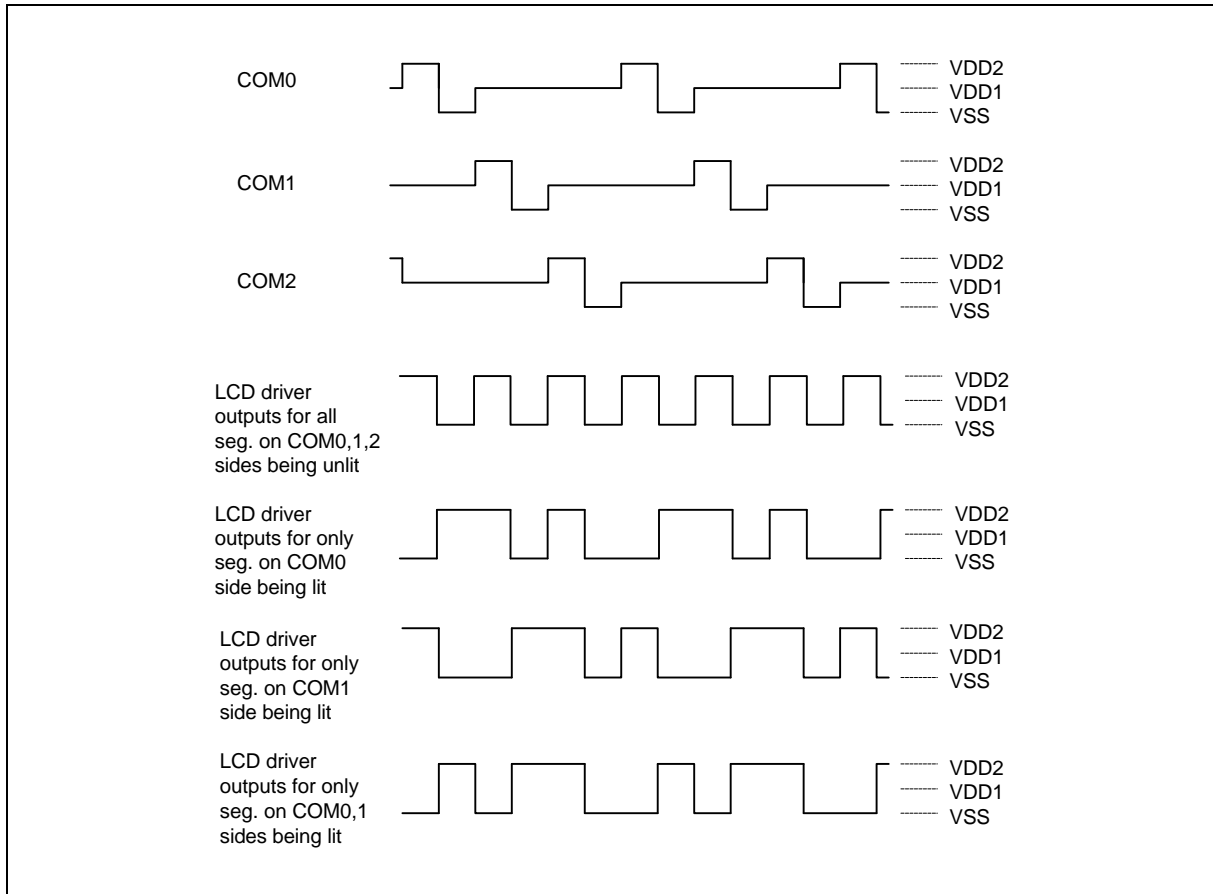



1/2 Bias 1/3 Duty Lighting System (Example)- Normal Operating Mode, continued

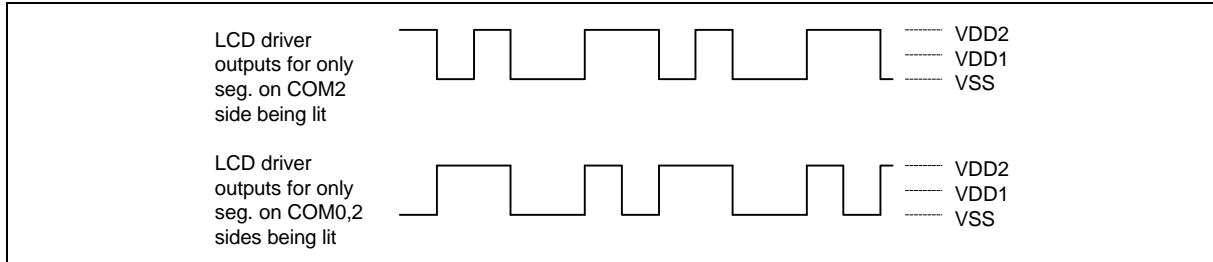

1/3 Bias 1/3 Duty Lighting System (Example)

Normal Operating Mode

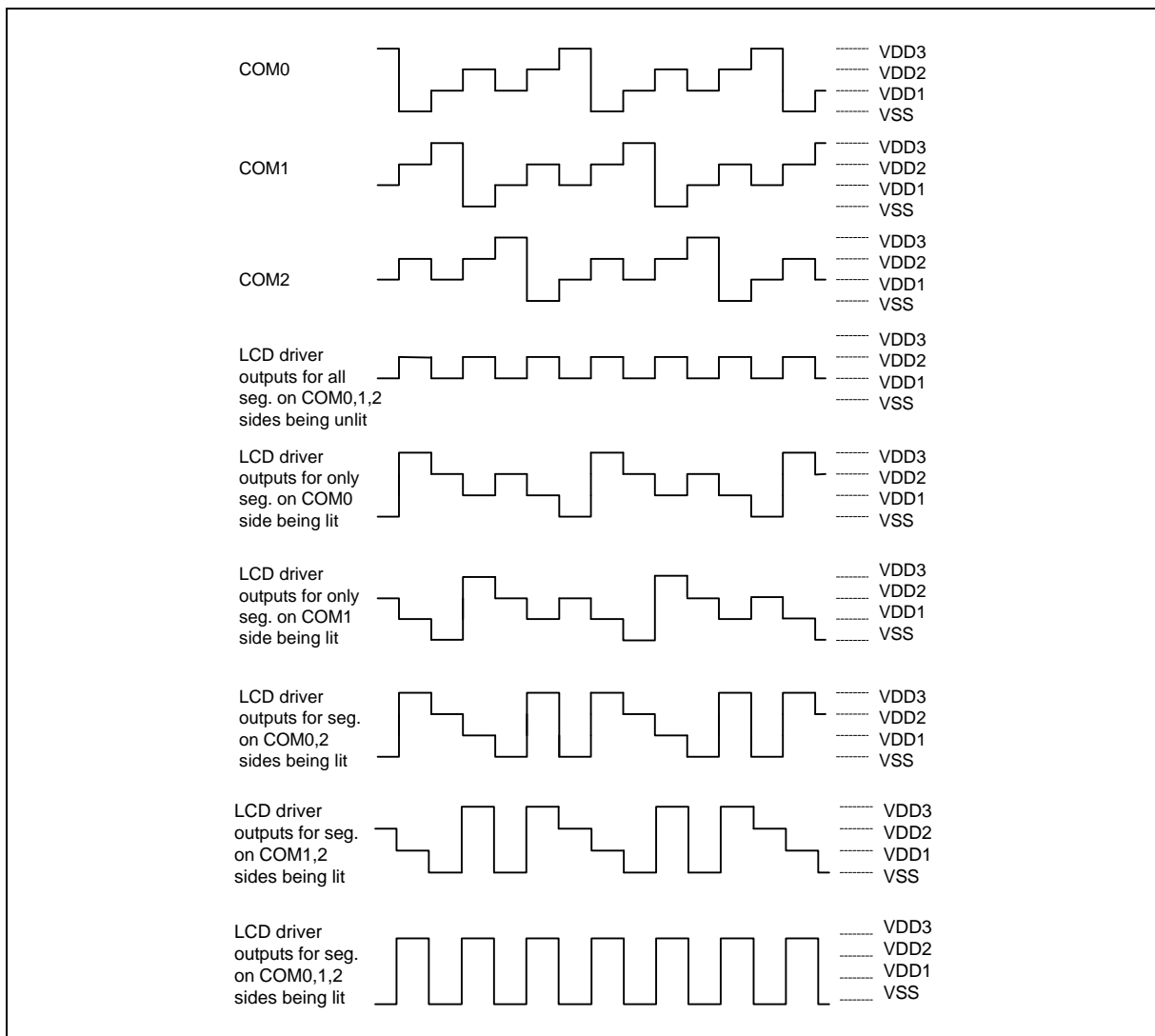



**1/3 Bias 1/4 Duty Lighting System (Example)**

**Normal Operating Mode**

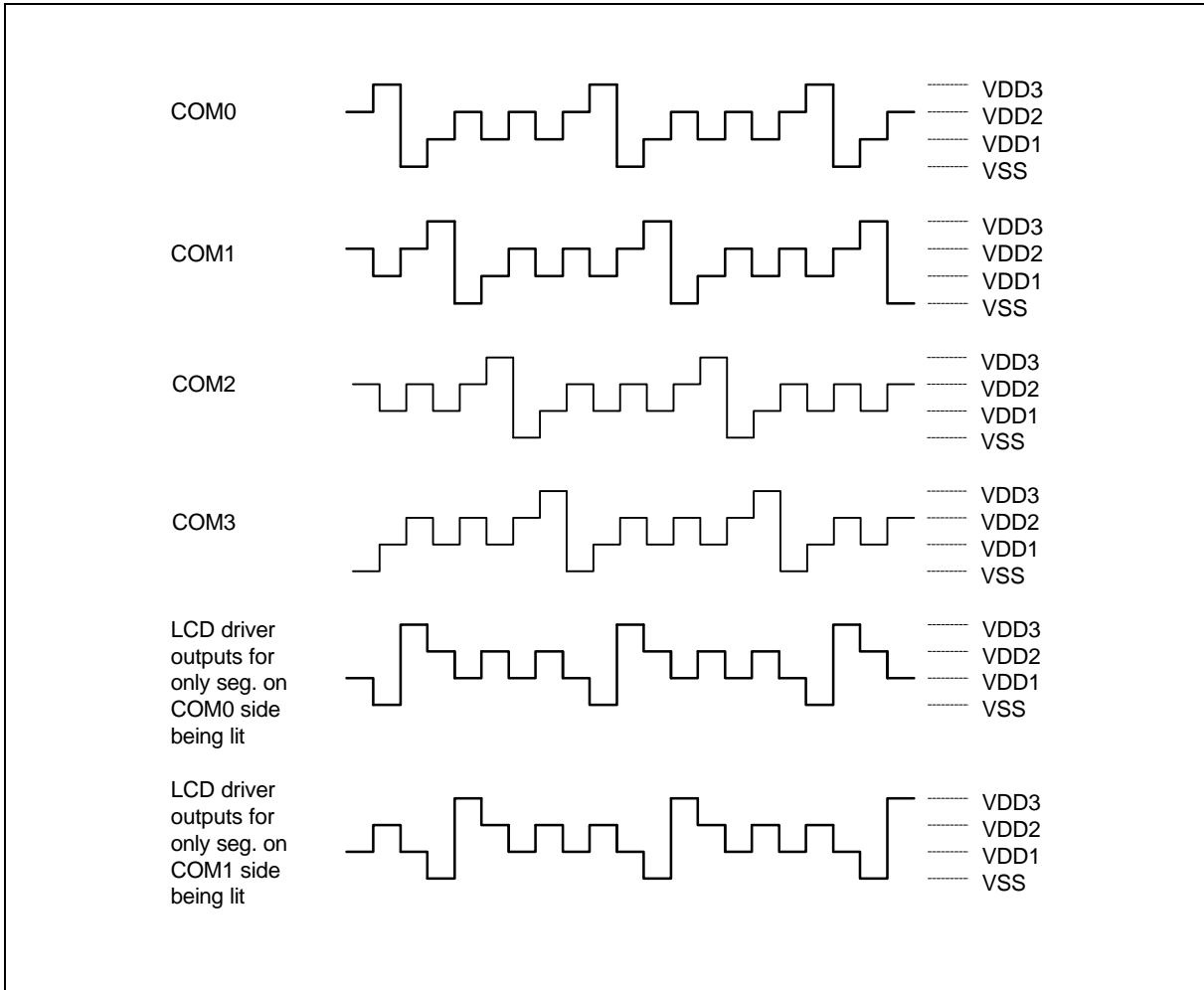

1/3 Bias 1/4 Duty Lighting System (Example)- Normal Operating Mode, continued

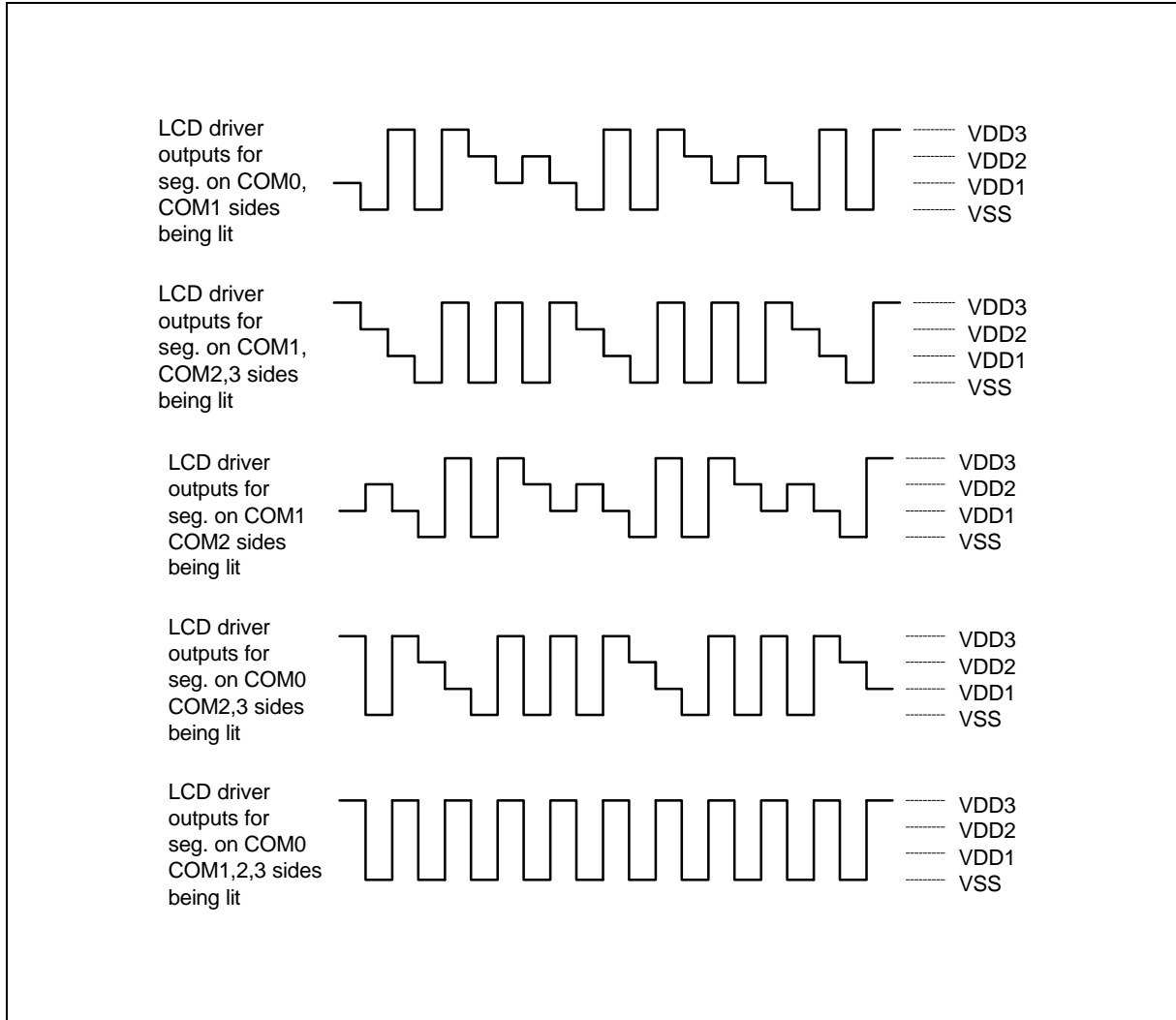

The power connections for each LCD driving mode, which are determined by a mask option, are shown below.

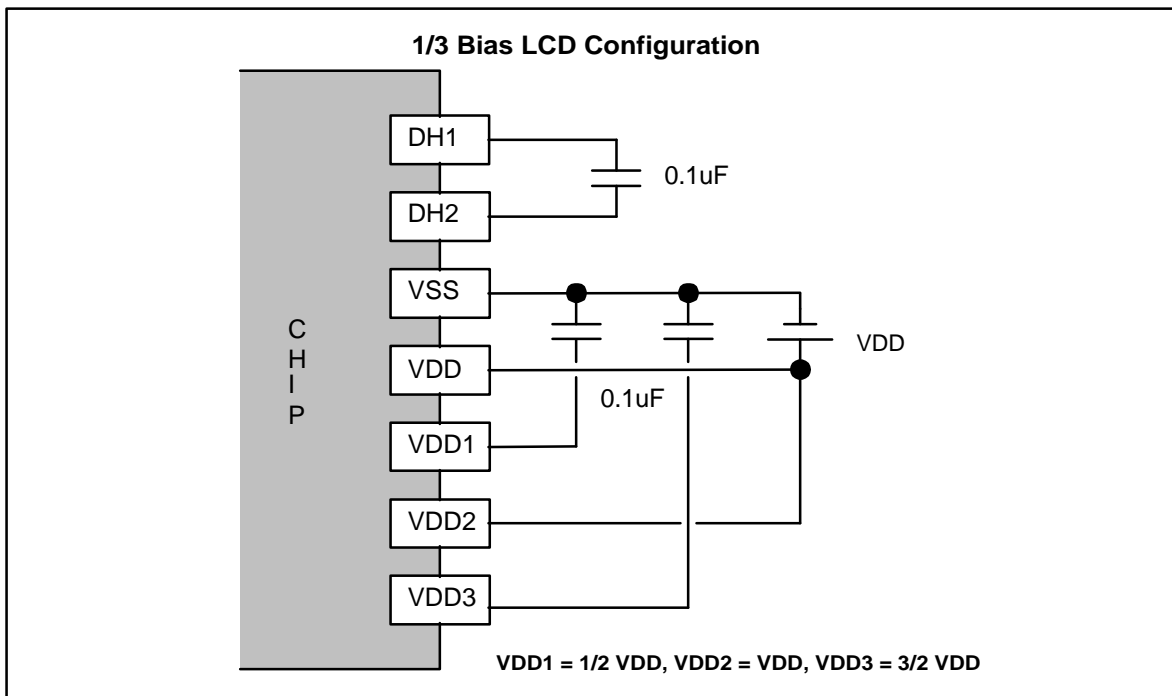
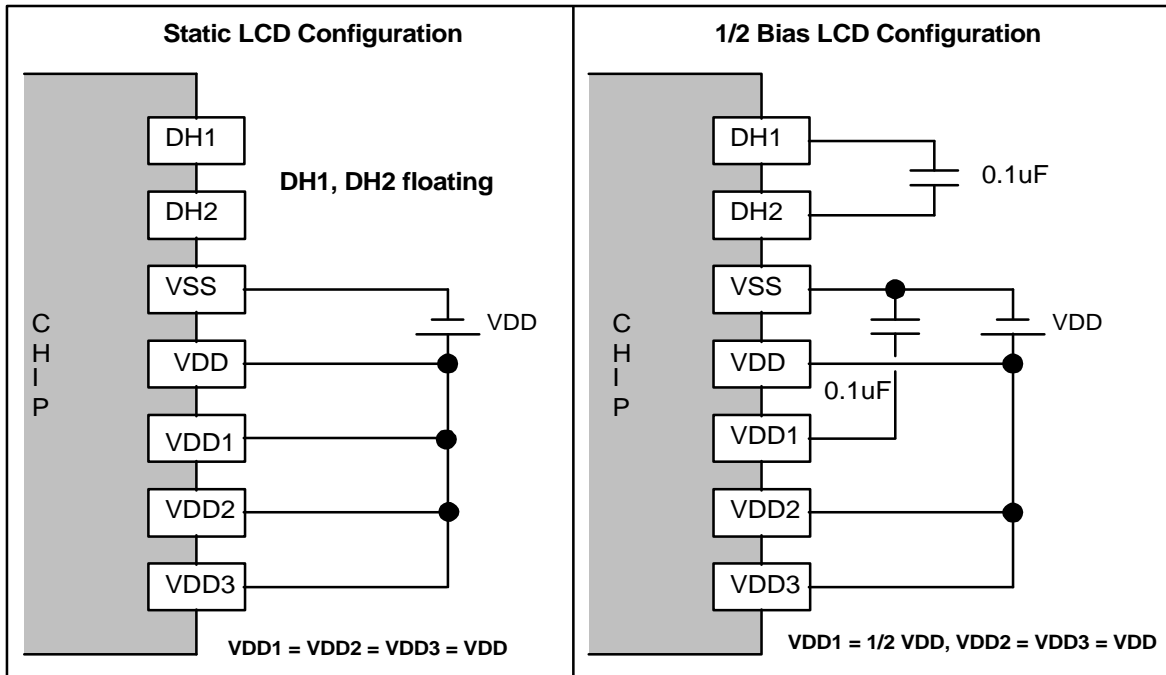

LCD Configuration, continued

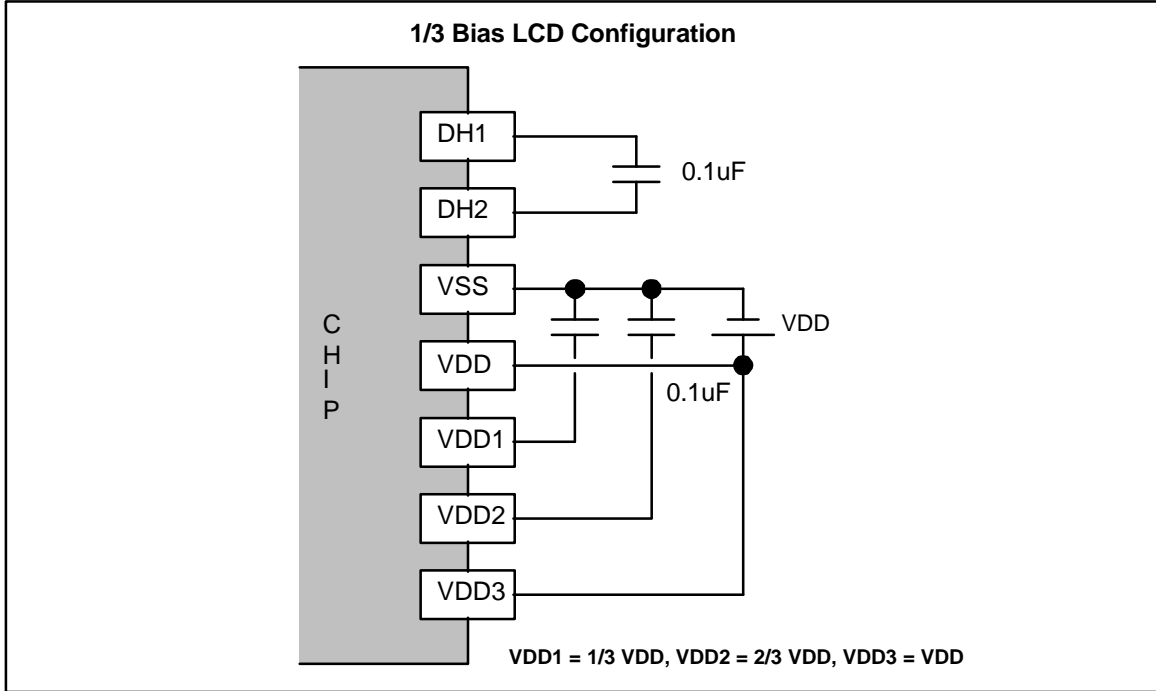

**ABSOLUTE MAXIMUM RATINGS**

PARAMETER	RATING	UNIT
Supply Voltage to Ground Potential	-0.3 to +7.0	V
Applied Input/Output Voltage	-0.3 to +7.0	V
Power Dissipation	120	mW
Ambient Operating Temperature	0 to +70	°C
Storage Temperature	-55 to +150	°C

Note: Exposure to conditions beyond those listed under Absolute Maximum Ratings may adversely affect the life and reliability of the device.

## DC CHARACTERISTICS

(V<sub>DD</sub>-V<sub>SS</sub> = 3.0V, F<sub>m</sub> = 4.19 MHz, F<sub>s</sub> = 32.768 KHz, T<sub>A</sub> = 25° C, LCD on; unless otherwise specified)

PARAMETER	SYM.	CONDITIONS	MIN.	TYP.	MAX.	UNIT
Op. Voltage	V <sub>DD</sub>	-	2.2	-	5.5	V
Op. Current (Crystal Type)	IOP1	No load (Ext-V) In dual-clock normal operation	-	0.6	2.5	mA
Op. Current (RC Type)	IOP2	No load (Ext-V) In dual-clock normal operation	-	1	4	mA
Op. Current (Crystal Type)	IOP3	No load (Ext-V) In dual-clock slow operation and F <sub>m</sub> is stopped	-	8.5	20	μA
Hold Current (Crystal Type)	IHM1	Hold mode No load (Ext-V) In dual-clock normal operation	-	280	450	μA
Hold Current (RC Type)	IHM2	Hold mode No load (Ext-V) In dual-clock normal operation	-	500	600	μA
Hold Current (Crystal Type)	IHM3	Hold mode No load (Ext-V) In dual-clock slow operation and F <sub>m</sub> is stopped	-	4.0	6	μA
Stop Current (Crystal type)	ISM1	Stop mode No load (Ext-V) In dual-clock normal operation	-	4.0	6	μA
Stop Current (Crystal type)	ISM2	Stop mode No load (Ext-V) In single-clock operation	-	0.1	2	μA
Input Low Voltage	V <sub>IL</sub>	-	V <sub>SS</sub>	-	0.3 V <sub>DD</sub>	V
Input High Voltage	V <sub>IH</sub>	-	0.7 V <sub>DD</sub>	-	V <sub>DD</sub>	V
MFP Output Low Voltage	V <sub>ML</sub>	I <sub>OL</sub> = 3.5 mA	-	-	0.4	V
MFP Output High Voltage	V <sub>MH</sub>	I <sub>OH</sub> = 3.5 mA	2.4	-	-	V
Port RA, RB Output Low Voltage	V <sub>ABL</sub>	I <sub>OL</sub> = 2.0 mA	-	-	0.4	V
Port RA, RB Output High Voltage	V <sub>ABH</sub>	I <sub>OH</sub> = 2.0 mA	2.4	-	-	V

DC Characteristics, continue

PARAMETER	SYM.	CONDITIONS	MIN.	TYP.	MAX.	UNIT
LCD Supply Current	ILCD	All Seg. ON	-	-	6	μA
SEG0–SEG31 Sink Current (Used as LCD Output)	IOL1	VOL = 0.4V VLCD = 0.0V	0.4	-	-	μA
SEG0–SEG31 Drive Current (Used as LCD Output)	IOH1	VOH = 2.4V VLCD = 3.0V	0.3	-	-	μA
Segment Output Low Voltage (Used as DC Output)	VSL	IOL = 0.6 mA	-	-	0.4	V
Segment Output High Voltage (Used as DC Output)	VSH	IOH = 3 μA	2.4	-	-	V
Port RE Sink Current	IEL	VOL = 0.9V	9	13.5	-	mA
Port RE Source Current	IEH	VOH = 2.4V	0.4	1.2	-	mA
Input Port Pull-up Resistor	RCD	Port RC, RD	100	350	1000	KΩ
RES Pull-up Resistor	RRES	-	20	100	500	KΩ

## AC CHARACTERISTICS

(VDD–VSS = 3.0V, TA = 25° C, unless otherwise specified)

PARAMETER	SYM.	CONDITIONS	MIN.	TYP.	MAX.	UNIT
Op. Frequency	FOSC	RC type	-	-	4000	KHz
		Crystal type 1 (Option low speed type)	-	32.768	-	
		Crystal type 2 (Option high speed type)	400	-	4190	
Frequency Deviation by Voltage Drop for RC Oscillator	$\frac{\Delta f}{f}$	$\frac{f(3V) - f(2.4V)}{f(3V)}$	-	-	10	%
Instruction Cycle Time	Ti	One machine cycle	-	4/FOSC	-	S
Reset Active Width	TRAW	FOSC = 32.768 KHz	1	-	-	μS
Interrupt Active Width	TIAW	FOSC = 32.768 KHz	1	-	-	μS

## PAD ASSIGNMENT & POSITIONS

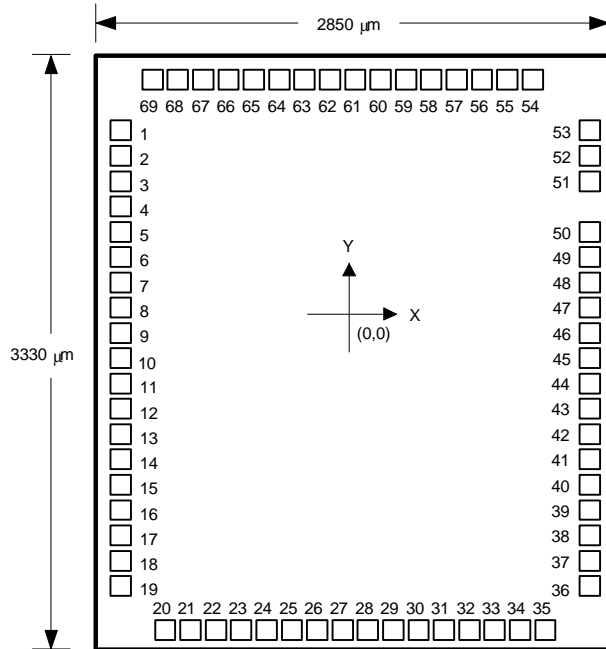

Note: The chip substrate must be connected to system ground (Vss).

PAD NO.	PAD NAME	X	Y	PAD NO.	PAD NAME	X	Y
1	RE2	-1227.00	1122.00	11	SEG3	-1227.00	-178.00
2	RE3	-1227.00	992.00	12	SEG4	-1227.00	-308.00
3	Vss	-1227.00	862.00	13	SEG5	-1227.00	-438.00
4	COM3	-1227.00	732.00	14	SEG6	-1227.00	-568.00
5	COM2	-1227.00	602.00	15	SEG7	-1227.00	-698.00
6	COM1	-1227.00	472.00	16	SEG8	-1227.00	-828.00
7	COM0	-1227.00	342.00	17	SEG9	-1227.00	-958.00
8	SEG0	-1227.00	212.00	18	SEG10	-1227.00	-1088.00
9	SEG1	-1227.00	82.00	19	SEG11	-1227.00	-1218.00
10	SEG2	-1227.00	-48.00	20	SEG12	-975.00	-1468.00

# W741C260



Continued

PAD NO.	PAD NAME	X	Y	PAD NO.	PAD NAME	X	Y
21	SEG13	-845.00	-1468.00	46	XIN2	1227.00	82.00
22	SEG14	-715.00	-1468.00	47	VDD	1227.00	212.00
23	SEG15	-585.00	-1468.00	48	XOUT1	1227.00	342.00
24	SEG16	-455.00	-1468.00	49	XIN1	1227.00	472.00
25	SEG17	-325.00	-1468.00	50	$\overline{\text{RES}}$	1227.00	602.00
26	SEG18	-195.00	-1468.00	51	MFP	1227.00	862.00
27	SEG19	-65.00	-1468.00	52	RA0	1227.00	992.00
28	SEG20	65.00	-1468.00	53	RA1	1227.00	1122.00
29	SEG21	195.00	-1468.00	54	RA2	1041.10	1453.20
30	SEG22	325.00	-1468.00	55	RA3	911.10	1453.20
31	SEG23	455.00	-1468.00	56	RB0	781.10	1453.20
32	SEG24	585.00	-1468.00	57	RB1	651.10	1453.20
33	SEG25	715.00	-1468.00	58	RB2	521.10	1453.20
34	SEG26	845.00	-1468.00	59	RB3	391.10	1453.20
35	SEG27	975.00	-1468.00	60	RC0	261.10	1453.20
36	SEG28	1227.00	-1218.00	61	RC1	131.10	1453.20
37	SEG29	1227.00	-1088.00	62	RC2	1.10	1453.20
38	SEG30	1227.00	-958.00	63	RC3	-128.90	1453.20
39	SEG31	1227.00	-828.00	64	RD0	-258.90	1453.20
40	VDD3	1227.00	-698.00	65	RD1	-388.90	1453.20
41	VDD2	1227.00	-568.00	66	RD2	-518.90	1453.20
42	VDD1	1227.00	-438.00	67	RD3	-648.90	1453.20
43	DH2	1227.00	-308.00	68	RE0	-778.90	1453.20
44	DH1	1227.00	-178.00	69	RE1	-908.90	1453.20
45	XOUT2	1227.00	-48.00				

**TYPICAL APPLICATION CIRCUIT**

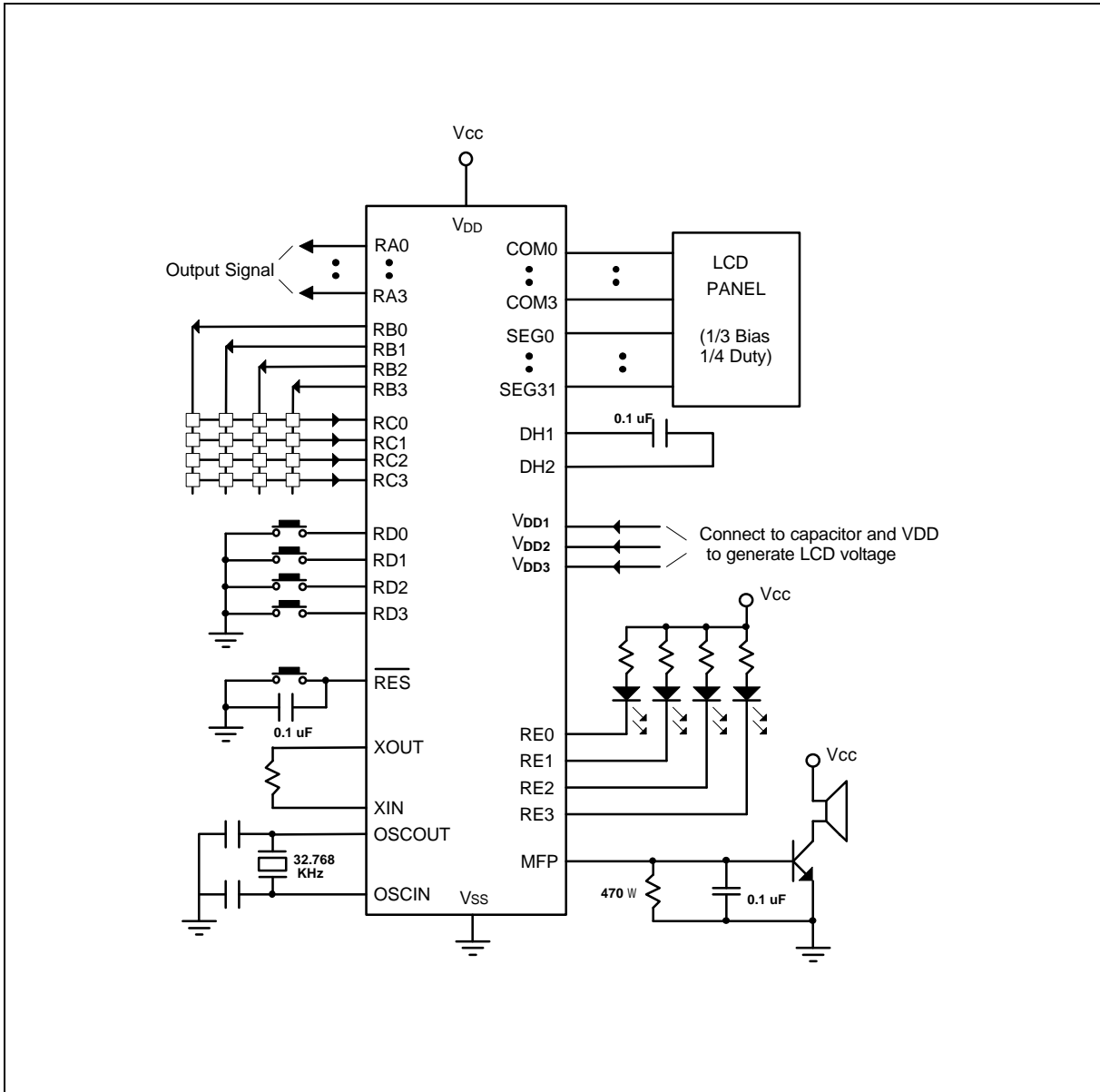



## INSTRUCTION SET TABLE

### Symbol Description

ACC:	Accumulator
ACC.n:	Accumulator bit n
WR:	Working Register
PAGE:	Page Register
MR0:	Mode Register 0
MR1:	Mode Register 1
PM0:	Port Mode 0
PM1:	Port Mode 1
PM2:	Port Mode 2
PSR0:	Port Status Register 0
R:	Memory (RAM) of address R
LCDR:	LCD data RAM of address LDR
R.n:	Memory bit n of address R
I:	Constant parameter
L:	Branch or jump address
CF:	Carry Flag
ZF:	Zero Flag
PC:	Program Counter
TM0:	Timer 0
TM1:	Timer 1
IEF.n:	Interrupt Enable Flag n
HCF.n:	HOLD mode release Condition Flag n
HEF.n:	HOLD mode release Enable Flag n
PEF.n:	Port Enable Flag n
EVFn:	Event Flag n
! =:	Not equal
&:	AND
^:	OR



Symbol Description, continued

EX: Exclusive OR  
 ←: Transfer direction, result

[PAGE\*10H+(): Contents of address PAGE(bit2, bit1, bit0)\*10H+()

[P(): Contents of port P()

**Instruction Set Table 1**

MNEMONIC		FUNCTION	FLAG AFFECTED	CYCLE
<b>Arithmetic</b>				
ADD	R, ACC	$ACC \leftarrow (R) + (ACC)$	ZF, CF	1
ADD	WR, #I	$ACC \leftarrow (WR) + I$	ZF, CF	1
ADDR	R, ACC	$ACC, R \leftarrow (R) + (ACC)$	ZF, CF	1
ADDR	WR, #I	$ACC, WR \leftarrow (WR) + I$	ZF, CF	1
ADC	R, ACC	$ACC \leftarrow (R) + (ACC) + (CF)$	ZF, CF	1
ADC	WR, #I	$ACC \leftarrow (WR) + I + (CF)$	ZF, CF	1
ADCR	R, ACC	$ACC, R \leftarrow (R) + (ACC) + (CF)$	ZF, CF	1
ADCR	WR, #I	$ACC, WR \leftarrow (WR) + I + (CF)$	ZF, CF	1
ADU	R, ACC	$ACC \leftarrow (R) + (ACC)$	ZF	1
ADU	WR, #I	$ACC \leftarrow (WR) + I$	ZF	1
ADUR	R, ACC	$ACC, R \leftarrow (R) + (ACC)$	ZF	1
ADUR	WR, #I	$ACC, W R \leftarrow (WR) + I$	ZF	1
SUB	R, ACC	$ACC \leftarrow (R) - (ACC)$	ZF, CF	1
SUB	WR, #I	$ACC \leftarrow (WR) - I$	ZF, CF	1
SUBR	R, ACC	$ACC, R \leftarrow (R) - (ACC)$	ZF, CF	1
SUBR	WR, #I	$ACC, WR \leftarrow (WR) - I$	ZF, CF	1
SBC	R, ACC	$ACC \leftarrow (R) - (ACC) - (CF)$	ZF, CF	1
SBC	WR, #I	$ACC \leftarrow (WR) - I - (CF)$	ZF, CF	1
SBCR	R, ACC	$ACC, R \leftarrow (R) - (ACC) - (CF)$	ZF, CF	1
SBCR	WR, #I	$ACC, WR \leftarrow (WR) - I - (CF)$	ZF, CF	1
INC	R	$ACC, R \leftarrow (R) + 1$	ZF, CF	1
DEC	R	$ACC, R \leftarrow (R) - 1$	ZF, CF	1



Instruction Set Table 1, continued

MNEMONIC		FUNCTION	FLAG AFFECTED	CYCLE
<b>Logic Operations</b>				
ANL	R, ACC	ACC←(R) & (ACC)	ZF	1
ANL	WR, #I	ACC←(WR) & I	ZF	1
ANLR	R, ACC	ACC, R←(R) & (ACC)	ZF	1
ANLR	WR, #I	ACC, WR←(WR) & I	ZF	1
ORL	R, ACC	ACC←(R) ^ (ACC)	ZF	1
ORL	WR, #I	ACC←(WR) ^ I	ZF	1
ORLR	R, ACC	ACC, R←(R) ^ (ACC)	ZF	1
ORLR	WR, #I	ACC, WR←(WR) ^ I	ZF	1
XRL	R, ACC	ACC←(R) EX (ACC)	ZF	1
XRL	WR, #I	ACC←(WR) EX I	ZF	1
XRLR	R, ACC	ACC, R←(R) EX (ACC)	ZF	1
XRLR	WR, #I	ACC, WR←(WR) EX I	ZF	1
<b>Branch</b>				
JMP	L	PC10-PC0←L10-L0		1
JB0	L	PC10-PC0←L10-L0; if ACC.0 = "1"		1
JB1	L	PC10-PC0←L10-L0; if ACC.1 = "1"		1
JB2	L	PC10-PC0←L10-L0; if ACC.2 = "1"		1
JB3	L	PC10-PC0←L10-L0; if ACC.3 = "1"		1
JZ	L	PC10-PC0←L10-L0; if ACC = 0		1
JNZ	L	PC10-PC0←L10-L0; if ACC != 0		1
JC	L	PC10-PC0←L10-L0; if CF = "1"		1
JNC	L	PC10-PC0←L10-L0; if CF != "1"		1
DSKZ	R	ACC, R←(R) - 1; skip if ACC = 0	ZF, CF	1
DSKNZ	R	ACC, R←(R) - 1; skip if ACC != 0	ZF, CF	1
SKB0	R	Skip if R.0 = "1"		1
SKB1	R	Skip if R.1 = "1"		1
SKB2	R	Skip if R.2 = "1"		1
SKB3	R	Skip if R.3 = "1"		1



Instruction Set Table 1, continued

MNEMONIC	FUNCTION	FLAG AFFECTED	CYCLE
<b>Data Move</b>			
MOV WR, R	WR←(R)		1
MOV R, WR	R←(WR)		1
MOVA WR, R	ACC, WR←(R)	ZF	1
MOVA R, WR	ACC, R←(WR)	ZF	1
MOV R, ACC	R←(ACC)		1
MOV ACC, R	ACC←(R)	ZF	1
MOV R, #I	R←I		1
MOV WR, @R	WR←[PR (bit2, bit1, bit0) × 10H + (R)]		2
MOV @R, WR	[PR (bit2, bit1, bit0) × 10H +(R)]←WR		2
MOV TABH, R	TAB High addresss ← R		1
MOV TABL, R	TAB Low addresss ← R		1
MOVC R	R←[ TAB × 10H + (ACC)]		2
MOVC WR, #I	WR ← [(I6 ~ I0) × 10H + (ACC)]		2
<b>Input &amp; Output</b>			
MOVA R, RA	ACC, R←[RA]	ZF	1
MOVA R, RB	ACC, R←[RB]	ZF	1
MOVA R, RC	ACC, R←[RC]	ZF	1
MOVA R, RD	ACC, R←[RD]	ZF	1
MOV RA, R	[RA]←(R)		1
MOV RB, R	[RB]←(R)		1
MOV RE, R	[RE]←(R)		1
MOV MFP, #I	[MFP]← I		1
<b>Flag &amp; Register</b>			
MOVA R, PAGE	ACC, R←PAGE (Page Register)	ZF	1
MOV PAGE, R	PAGE←(R)		1
MOV PAGE, #I	PAGE←I		1
MOV MR0, #I	MR0←I		1
MOV MR1, #I	MR1←I		1

Instruction Set Table 1, continued

MNEMONIC	FUNCTION	FLAG AFFECTED	CYCLE
MOVA R, CF	ACC.0, R.0←CF	ZF	1
MOV CF, R	CF←(R.0)	CF	1
MOVA R, HCFL	ACC, R←HCF0–HCF3	ZF	1
MOVA R, HCFH	ACC, R←HCF4–HCF7	ZF	1
CLR PMF, #I	Clear Parameter Flag if In = 1		1
SET PMF, #I	Set Parameter Flag if In = 1		1
MOV PM0, #I	Port Mode 0← I		1
MOV PM1, #I	Port Mode 1← I		1
MOV PM2, #I	Port Mode 2← I		1
CLR EVF, #I	Clear Event Flag if In = 1		1
MOV PEF, #I	Set/Reset Port Enable Flag		1
MOV IEF, #I	Set/Reset Interrupt Enable Flag		1
MOV HEF, #I	Set/Reset HOLD mode release Enable Flag		1
MOV SEF, #I	Set/Reset STOP mode wake-up Enable Flag for RC port		1
MOV SCR, #I	Set/Reset System clock Control Resgister		1
MOVA R, PSR0	ACC, R←Port Status Register 0	ZF	1
CLR PSR0	Clear Port Status Register 0		1
SET CF	Set Carry Flag	CF	1
CLR CF	Clear Carry Flag	CF	1
CLR DIVR0	Clear the last 4-bit of the Divider		1
CLR WDT	Clear WatchDog Timer		1
<b>Shift &amp; Rotate</b>			
SHRC R	ACC.n, R.n←(R.n+1); ACC.3, R.3←0; CF←R.0	ZF, CF	1
RRC R	ACC.n, R.n←(R.n+1); ACC.3, R.3←CF; CF←R.0	ZF, CF	1
SHLC R	ACC.n, R.n←(R.n-1); ACC.0, R.0←0; CF←R.3	ZF, CF	1
RLC R	ACC.n, R.n←(R.n-1); ACC.0, R.0←CF; CF←R.3	ZF, CF	1



Instruction Set Table 1, continued

MNEMONIC		FUNCTION	FLAG AFFECTED	CYCLE
<b>LCD</b>				
MOV	LCDR, #I	LCDR ← I		1
MOV	WR, LCDR	WR ← (LCDR)		1
MOV	LCDR, WR	LCDR ← (WR)		1
MOV	LCDR, ACC	LCDR ← (ACC)		1
MOV	LCDM, #I	Select LCD output mode type		1
LCDON		LCD ON		1
LCDOFF		LCD OFF		1
<b>Timer</b>				
MOV	TM0H, R	Timer 0 High register ← R		1
MOV	TM0L, R	Timer 0 Low register ← R		1
MOV	TM0, #I	Timer 0 set		1
MOV	TM1H, R	Timer 1 High register ← R		1
MOV	TM1L, R	Timer 1 Low register ← R		1
MOV	TM1, #I	Timer 1 set		1
<b>Subroutine</b>				
CALL	L	STACK ← (PC)+1; PC10-PC0 ← L10-L0		1
RTN		(PC) ← STACK		1
<b>Other</b>				
HOLD		Enter Hold mode		1
STOP		Enter Stop mode		1
NOP		No Operation		1
EN	INT	Enable Interrupt Function		1
DIS	INT	Disable Interrupt Function		1



**Instruction Set Table 2**

<b>ADC R, ACC</b>	<b>Add R to ACC with CF</b>																
Machine Code:	<table border="1" style="display: inline-table; margin-right: 20px;"> <tr> <td>0</td><td>0</td><td>0</td><td>0</td><td>1</td><td>0</td><td>0</td><td>0</td> </tr> </table> <table border="1" style="display: inline-table;"> <tr> <td>0</td><td>R6</td><td>R5</td><td>R4</td><td>R3</td><td>R2</td><td>R1</td><td>R0</td> </tr> </table>	0	0	0	0	1	0	0	0	0	R6	R5	R4	R3	R2	R1	R0
0	0	0	0	1	0	0	0										
0	R6	R5	R4	R3	R2	R1	R0										
Machine Cycle:	1																
Operation:	$ACC \leftarrow (R) + (ACC) + (CF)$																
Description:	The contents of the data memory location addressed by R6 to R0, ACC, and CF are binary added and the result is loaded into the ACC.																
Flag Affected:	CF & ZF																
<b>ADC WR, #I</b>	<b>Add immediate data to WR with CF</b>																
Machine Code:	<table border="1" style="display: inline-table; margin-right: 20px;"> <tr> <td>0</td><td>0</td><td>0</td><td>0</td><td>1</td><td>1</td><td>0</td><td>0</td> </tr> </table> <table border="1" style="display: inline-table;"> <tr> <td>I3</td><td>I2</td><td>I1</td><td>I0</td><td>W3</td><td>W2</td><td>W1</td><td>W0</td> </tr> </table>	0	0	0	0	1	1	0	0	I3	I2	I1	I0	W3	W2	W1	W0
0	0	0	0	1	1	0	0										
I3	I2	I1	I0	W3	W2	W1	W0										
Machine Cycle:	1																
Operation:	$ACC \leftarrow (WR) + I + (CF)$																
Description:	The contents of the Working Register (WR), I and CF are binary added and the result is loaded into the ACC.																
Flag Affected:	CF & ZF																
<b>ADCR R, ACC</b>	<b>Add R to ACC with CF</b>																
Machine Code:	<table border="1" style="display: inline-table; margin-right: 20px;"> <tr> <td>0</td><td>0</td><td>0</td><td>0</td><td>1</td><td>0</td><td>0</td><td>1</td> </tr> </table> <table border="1" style="display: inline-table;"> <tr> <td>0</td><td>R6</td><td>R5</td><td>R4</td><td>R3</td><td>R2</td><td>R1</td><td>R0</td> </tr> </table>	0	0	0	0	1	0	0	1	0	R6	R5	R4	R3	R2	R1	R0
0	0	0	0	1	0	0	1										
0	R6	R5	R4	R3	R2	R1	R0										
Machine Cycle:	1																
Operation:	$ACC, R \leftarrow (R) + (ACC) + (CF)$																
Description:	The contents of the data memory location addressed by R6 to R0, ACC, and CF are binary added and the result is placed in the ACC and the data memory.																
Flag Affected:	CF & ZF																



Instruction Set Table 2, continued

<b>ADCR WR, #I</b>	<b>Add immediate data to WR with CF</b>																
Machine Code:	<table border="1" style="display: inline-table; margin-right: 20px;"> <tr> <td>0</td><td>0</td><td>0</td><td>0</td><td>1</td><td>1</td><td>0</td><td>1</td> </tr> </table> <table border="1" style="display: inline-table;"> <tr> <td>I3</td><td>I2</td><td>I1</td><td>I0</td><td>W3</td><td>W2</td><td>W1</td><td>W0</td> </tr> </table>	0	0	0	0	1	1	0	1	I3	I2	I1	I0	W3	W2	W1	W0
0	0	0	0	1	1	0	1										
I3	I2	I1	I0	W3	W2	W1	W0										
Machine Cycle:	1																
Operation:	$ACC, WR \leftarrow (WR) + I + (CF)$																
Description:	The contents of the Working Register (WR), I, CF are binary added and the result is placed in the ACC and the WR.																
Flag Affected:	CF & ZF																
<b>ADD R, ACC</b>	<b>Add R to ACC</b>																
Machine Code:	<table border="1" style="display: inline-table; margin-right: 20px;"> <tr> <td>0</td><td>0</td><td>0</td><td>1</td><td>1</td><td>0</td><td>0</td><td>0</td> </tr> </table> <table border="1" style="display: inline-table;"> <tr> <td>0</td><td>R6</td><td>R5</td><td>R4</td><td>R3</td><td>R2</td><td>R1</td><td>R0</td> </tr> </table>	0	0	0	1	1	0	0	0	0	R6	R5	R4	R3	R2	R1	R0
0	0	0	1	1	0	0	0										
0	R6	R5	R4	R3	R2	R1	R0										
Machine Cycle:	1																
Operation:	$ACC \leftarrow (R) + (ACC)$																
Description:	The contents of the data memory location addressed by R6 to R0 and ACC are binary added and the result is loaded into the ACC.																
Flag Affected:	CF & ZF																
<b>ADD WR, #I</b>	<b>Add immediate data to WR</b>																
Machine Code:	<table border="1" style="display: inline-table; margin-right: 20px;"> <tr> <td>0</td><td>0</td><td>0</td><td>1</td><td>1</td><td>1</td><td>0</td><td>0</td> </tr> </table> <table border="1" style="display: inline-table;"> <tr> <td>I3</td><td>I2</td><td>I1</td><td>I0</td><td>W3</td><td>W2</td><td>W1</td><td>W0</td> </tr> </table>	0	0	0	1	1	1	0	0	I3	I2	I1	I0	W3	W2	W1	W0
0	0	0	1	1	1	0	0										
I3	I2	I1	I0	W3	W2	W1	W0										
Machine Cycle:	1																
Operation:	$ACC \leftarrow (WR) + I$																
Description:	The contents of the Working Register (WR) and the immediate data I are binary added and the result is loaded into the ACC.																
Flag Affected:	CF & ZF																



Instruction Set Table 2, continued

<b>ADDR R, ACC</b>	<b>Add R to ACC</b>																
Machine Code:	<table border="1" style="display: inline-table; vertical-align: middle;"> <tr> <td>0</td><td>0</td><td>0</td><td>1</td><td>1</td><td>0</td><td>0</td><td>1</td> </tr> </table> <table border="1" style="display: inline-table; vertical-align: middle; margin-left: 20px;"> <tr> <td>0</td><td>R6</td><td>R5</td><td>R4</td><td>R3</td><td>R2</td><td>R1</td><td>R0</td> </tr> </table>	0	0	0	1	1	0	0	1	0	R6	R5	R4	R3	R2	R1	R0
0	0	0	1	1	0	0	1										
0	R6	R5	R4	R3	R2	R1	R0										
Machine Cycle:	1																
Operation:	$ACC, R \leftarrow (R) + (ACC)$																
Description:	The contents of the data memory location addressed by R6 to R0 and ACC are binary added and the result is placed in the ACC and the data memory.																
Flag Affected:	CF & ZF																
<b>ADDR WR, #I</b>	<b>Add immediate data to WR</b>																
Machine Code:	<table border="1" style="display: inline-table; vertical-align: middle;"> <tr> <td>0</td><td>0</td><td>0</td><td>1</td><td>1</td><td>1</td><td>0</td><td>1</td> </tr> </table> <table border="1" style="display: inline-table; vertical-align: middle; margin-left: 20px;"> <tr> <td>I3</td><td>I2</td><td>I1</td><td>I0</td><td>W3</td><td>W2</td><td>W1</td><td>W0</td> </tr> </table>	0	0	0	1	1	1	0	1	I3	I2	I1	I0	W3	W2	W1	W0
0	0	0	1	1	1	0	1										
I3	I2	I1	I0	W3	W2	W1	W0										
Machine Cycle:	1																
Operation:	$ACC, WR \leftarrow (WR) + I$																
Description:	The contents of the Working Register (WR) and the immediate data I are binary added and the result is placed in the ACC and the WR.																
Flag Affected:	CF & ZF																
<b>ADU R, ACC</b>	<b>Add R to ACC with Carry Flag unchanged</b>																
Machine Code:	<table border="1" style="display: inline-table; vertical-align: middle;"> <tr> <td>0</td><td>0</td><td>1</td><td>0</td><td>1</td><td>0</td><td>0</td><td>0</td> </tr> </table> <table border="1" style="display: inline-table; vertical-align: middle; margin-left: 20px;"> <tr> <td>0</td><td>R6</td><td>R5</td><td>R4</td><td>R3</td><td>R2</td><td>R1</td><td>R0</td> </tr> </table>	0	0	1	0	1	0	0	0	0	R6	R5	R4	R3	R2	R1	R0
0	0	1	0	1	0	0	0										
0	R6	R5	R4	R3	R2	R1	R0										
Machine Cycle:	1																
Operation:	$ACC \leftarrow (R) + (ACC)$																
Description:	The contents of the data memory location addressed by R6 to R0 and ACC are binary added and the result is loaded into the ACC.																
Flag Affected:	ZF																



Instruction Set Table 2, continued

<b>ADU WR, #I</b>	<b>Add immediate data to WR with Carry Flag unchanged</b>	
Machine Code:	0 0 1 0 1 1 0 0	I3 I2 I1 I0 W3 W2 W1 W0
Machine Cycle:	1	
Operation:	ACC ← (WR) + I	
Description:	The contents of the Working Register (WR) and the immediate data I are binary added and the result is loaded into the ACC.	
Flag Affected:	ZF	
<b>ADUR R, ACC</b>	<b>Add R to ACC with Carry Flag unchanged</b>	
Machine Code:	0 0 1 0 1 0 0 1	0 R6 R5 R4 R3 R2 R1 R0
Machine Cycle:	1	
Operation:	ACC, R ← (R) + (ACC)	
Description:	The contents of the data memory location addressed by R6 to R0 and ACC are binary added and the result is placed in the ACC and the data memory.	
Flag Affected:	ZF	
<b>ADUR WR, #I</b>	<b>Add immediate data to WR with Carry Flag unchanged</b>	
Machine Code:	0 0 1 0 1 1 0 1	I3 I2 I1 I0 W3 W2 W1 W0
Machine Cycle:	1	
Operation:	ACC, WR ← (WR) + I	
Description:	The contents of the Working Register (WR) and the immediate data I are binary added and the result is placed in the WR and the ACC.	
Flag Affected:	ZF	



Instruction Set Table 2, continued

<b>ANL R, ACC</b>	<b>And R to ACC</b>		
Machine Code:	<table border="1"> <tr> <td>0 0 1 0 1 0 1 0</td> <td>0 R6 R5 R4 R3 R2 R1 R0</td> </tr> </table>	0 0 1 0 1 0 1 0	0 R6 R5 R4 R3 R2 R1 R0
0 0 1 0 1 0 1 0	0 R6 R5 R4 R3 R2 R1 R0		
Machine Cycle:	1		
Operation:	$ACC \leftarrow (R) \& (ACC)$		
Description:	The contents of the data memory location addressed by R6 to R0 and the ACC are ANDed and the result is loaded into the ACC.		
Flag Affected:	ZF		
<b>ANL WR, #I</b>	<b>And immediate data to WR</b>		
Machine Code:	<table border="1"> <tr> <td>0 0 1 0 1 1 1 0</td> <td>I3 I2 I1 I0 W3 W2 W1 W0</td> </tr> </table>	0 0 1 0 1 1 1 0	I3 I2 I1 I0 W3 W2 W1 W0
0 0 1 0 1 1 1 0	I3 I2 I1 I0 W3 W2 W1 W0		
Machine Cycle:	1		
Operation:	$ACC \leftarrow (WR) \& I$		
Description:	The contents of the Working Register (WR) and the immediate data I are ANDed and the result is loaded into the ACC.		
Flag Affected:	ZF		
<b>ANLR R, ACC</b>	<b>And R to ACC</b>		
Machine Code:	<table border="1"> <tr> <td>0 0 1 0 1 0 1 1</td> <td>0 R6 R5 R4 R3 R2 R1 R0</td> </tr> </table>	0 0 1 0 1 0 1 1	0 R6 R5 R4 R3 R2 R1 R0
0 0 1 0 1 0 1 1	0 R6 R5 R4 R3 R2 R1 R0		
Machine Cycle:	1		
Operation:	$ACC, R \leftarrow (R) \& (ACC)$		
Description:	The contents of the data memory location addressed by R6 to R0 and the ACC are ANDed and the result is placed in the data memory and the ACC.		
Flag Affected:	ZF		



Instruction Set Table 2, continued

<b>ANLR WR, #I</b>	<b>And immediate data to WR</b>																
Machine Code:	<table style="display: inline-table; border: 1px solid black; margin-right: 20px;"> <tr><td style="padding: 2px 5px;">0</td><td style="padding: 2px 5px;">0</td><td style="padding: 2px 5px;">1</td><td style="padding: 2px 5px;">0</td><td style="padding: 2px 5px;">1</td><td style="padding: 2px 5px;">1</td><td style="padding: 2px 5px;">1</td><td style="padding: 2px 5px;">1</td></tr> </table> <table style="display: inline-table; border: 1px solid black;"> <tr><td style="padding: 2px 5px;">I3</td><td style="padding: 2px 5px;">I2</td><td style="padding: 2px 5px;">I1</td><td style="padding: 2px 5px;">I0</td><td style="padding: 2px 5px;">W3</td><td style="padding: 2px 5px;">W2</td><td style="padding: 2px 5px;">W1</td><td style="padding: 2px 5px;">W0</td></tr> </table>	0	0	1	0	1	1	1	1	I3	I2	I1	I0	W3	W2	W1	W0
0	0	1	0	1	1	1	1										
I3	I2	I1	I0	W3	W2	W1	W0										
Machine Cycle:	1																
Operation:	ACC, WR ← (WR) & I																
Description:	The contents of the Working Register (WR) and the immediate data I are ANDed and the result is placed in the WR and the ACC.																
Flag Affected:	ZF																
<b>CALL L</b>	<b>Call subroutine</b>																
Machine Code:	<table style="display: inline-table; border: 1px solid black; margin-right: 20px;"> <tr><td style="padding: 2px 5px;">0</td><td style="padding: 2px 5px;">1</td><td style="padding: 2px 5px;">1</td><td style="padding: 2px 5px;">0</td><td style="padding: 2px 5px;">0</td><td style="padding: 2px 5px;">L10</td><td style="padding: 2px 5px;">L9</td><td style="padding: 2px 5px;">L8</td></tr> </table> <table style="display: inline-table; border: 1px solid black;"> <tr><td style="padding: 2px 5px;">L7</td><td style="padding: 2px 5px;">L6</td><td style="padding: 2px 5px;">L5</td><td style="padding: 2px 5px;">L4</td><td style="padding: 2px 5px;">L3</td><td style="padding: 2px 5px;">L2</td><td style="padding: 2px 5px;">L1</td><td style="padding: 2px 5px;">L0</td></tr> </table>	0	1	1	0	0	L10	L9	L8	L7	L6	L5	L4	L3	L2	L1	L0
0	1	1	0	0	L10	L9	L8										
L7	L6	L5	L4	L3	L2	L1	L0										
Machine Cycle:	1																
Operation:	STACK ← (PC)+1; PC10-PC0 ← L10-L0																
Description:	The next program counter (PC10 to PC0) is saved in the STACK and then the direct address (L10 to L0) is loaded into the program counter. A subroutine is called.																
<b>CLR CF</b>	<b>Clear CF</b>																
Machine Code:	<table style="display: inline-table; border: 1px solid black; margin-right: 20px;"> <tr><td style="padding: 2px 5px;">0</td><td style="padding: 2px 5px;">1</td><td style="padding: 2px 5px;">0</td><td style="padding: 2px 5px;">1</td><td style="padding: 2px 5px;">0</td><td style="padding: 2px 5px;">0</td><td style="padding: 2px 5px;">0</td><td style="padding: 2px 5px;">0</td></tr> </table> <table style="display: inline-table; border: 1px solid black;"> <tr><td style="padding: 2px 5px;">0</td><td style="padding: 2px 5px;">0</td><td style="padding: 2px 5px;">0</td><td style="padding: 2px 5px;">0</td><td style="padding: 2px 5px;">0</td><td style="padding: 2px 5px;">0</td><td style="padding: 2px 5px;">0</td><td style="padding: 2px 5px;">0</td></tr> </table>	0	1	0	1	0	0	0	0	0	0	0	0	0	0	0	0
0	1	0	1	0	0	0	0										
0	0	0	0	0	0	0	0										
Machine Cycle:	1																
Operation:	Clear CF																
Description:	Clear Carry Flag to 0.																
Flag Affected:	CF																



Instruction Set Table 2, continued

CLR	DIVR0	Reset the last 4 bits of the DIVideR0																
Machine Code:		<table border="1"> <tr> <td>0 0 0 1 0 1 1 1</td> <td>0 0 0 0 0 0 0 0</td> </tr> </table>	0 0 0 1 0 1 1 1	0 0 0 0 0 0 0 0														
0 0 0 1 0 1 1 1	0 0 0 0 0 0 0 0																	
Machine Cycle:		1																
Operation:		Reset the last 4 bits of the Divider0																
Description:		When this instruction is executed, the last 4 bits of the Divider0 (14 bits) are reset.																
CLR	EVF, #I	Clear EVent Flag																
Machine Code:		<table border="1"> <tr> <td>0 1 0 0 0 0 0 0</td> <td>17 16 15 14 13 12 11 10</td> </tr> </table>	0 1 0 0 0 0 0 0	17 16 15 14 13 12 11 10														
0 1 0 0 0 0 0 0	17 16 15 14 13 12 11 10																	
Machine Cycle:		1																
Operation:		Clear event flag																
Description:		<p>The condition corresponding to the data specified by I7 to I0 is controlled.</p> <table border="1"> <tr> <td>I0 to I8</td> <td>Mode after execution of instruction</td> </tr> <tr> <td>I0 = 1</td> <td>EVF0 caused by overflow from the Divider0 is reset.</td> </tr> <tr> <td>I1 = 1</td> <td>EVF1 caused by underflow from the Timer 0 is reset.</td> </tr> <tr> <td>I2 = 1</td> <td>EVF2 caused by signal change on port RC is reset.</td> </tr> <tr> <td>I3 = 1</td> <td>Reserved</td> </tr> <tr> <td>I4 = 1</td> <td>EVF4 caused by overflow from the Divider1 is reset.</td> </tr> <tr> <td>I5, I6</td> <td>Reserved</td> </tr> <tr> <td>I7 = 1</td> <td>EVF7 caused by underflow from the Timer 1 is reset.</td> </tr> </table>	I0 to I8	Mode after execution of instruction	I0 = 1	EVF0 caused by overflow from the Divider0 is reset.	I1 = 1	EVF1 caused by underflow from the Timer 0 is reset.	I2 = 1	EVF2 caused by signal change on port RC is reset.	I3 = 1	Reserved	I4 = 1	EVF4 caused by overflow from the Divider1 is reset.	I5, I6	Reserved	I7 = 1	EVF7 caused by underflow from the Timer 1 is reset.
I0 to I8	Mode after execution of instruction																	
I0 = 1	EVF0 caused by overflow from the Divider0 is reset.																	
I1 = 1	EVF1 caused by underflow from the Timer 0 is reset.																	
I2 = 1	EVF2 caused by signal change on port RC is reset.																	
I3 = 1	Reserved																	
I4 = 1	EVF4 caused by overflow from the Divider1 is reset.																	
I5, I6	Reserved																	
I7 = 1	EVF7 caused by underflow from the Timer 1 is reset.																	



Instruction Set Table 2, continued

CLR	PMF, #I	Clear ParaMeter Flag		
Machine Code:		<table border="1"> <tr> <td>0 0 0 1 0 1 1 0</td> <td>1 0 0 0 I3 I2 I1 I0</td> </tr> </table>	0 0 0 1 0 1 1 0	1 0 0 0 I3 I2 I1 I0
0 0 0 1 0 1 1 0	1 0 0 0 I3 I2 I1 I0			
Machine Cycle:		1		
Operation:		Clear Parameter Flag		
Description:		Description of each flag: I0, I1, I2 : Reserved  I3 = 1 : The input clock of the watchdog timer is Fosc/1024.		
CLR	PSR0	Clear Port Status Register 0 (RC port signal change flag)		
Machine Code:		<table border="1"> <tr> <td>0 1 0 0 0 0 1 0</td> <td>0 0 0 0 0 0 0 0</td> </tr> </table>	0 1 0 0 0 0 1 0	0 0 0 0 0 0 0 0
0 1 0 0 0 0 1 0	0 0 0 0 0 0 0 0			
Machine Cycle:		1		
Operation:		Clear Port Status Register 0 (RC port signal change flag)		
Description:		When this instruction is executed, the RC port signal change flag (PSR0) is cleared.		
CLR	WDT	Reset the last 4 bits of the WatchDog Timer		
Machine Code:		<table border="1"> <tr> <td>0 0 0 1 0 1 1 1</td> <td>1 0 0 0 0 0 0 0</td> </tr> </table>	0 0 0 1 0 1 1 1	1 0 0 0 0 0 0 0
0 0 0 1 0 1 1 1	1 0 0 0 0 0 0 0			
Machine Cycle:		1		
Operation:		Reset the last 4 bits of the watchdog timer		
Description:		When this instruction is executed, the last 4 bits of the watchdog timer are reset.		



Instruction Set Table 2, continued

<b>DEC R</b>	<b>Decrement R contents</b>																
Machine Code:	<table border="1" style="display: inline-table; margin-right: 20px;"> <tr> <td>0</td><td>1</td><td>0</td><td>0</td><td>1</td><td>0</td><td>1</td><td>0</td> </tr> </table> <table border="1" style="display: inline-table;"> <tr> <td>1</td><td>R6</td><td>R5</td><td>R4</td><td>R3</td><td>R2</td><td>R1</td><td>R0</td> </tr> </table>	0	1	0	0	1	0	1	0	1	R6	R5	R4	R3	R2	R1	R0
0	1	0	0	1	0	1	0										
1	R6	R5	R4	R3	R2	R1	R0										
Machine Cycle:	1																
Operation:	ACC, R ← (R) - 1																
Description:	Decrement the data memory contents and load result into the ACC and the data memory.																
Flag Affected:	CF & ZF																
<b>DIS INT</b>	<b>Disable Interrupt function</b>																
Machine Code:	<table border="1" style="display: inline-table; margin-right: 20px;"> <tr> <td>0</td><td>1</td><td>0</td><td>1</td><td>0</td><td>0</td><td>0</td><td>0</td> </tr> </table> <table border="1" style="display: inline-table;"> <tr> <td>1</td><td>0</td><td>0</td><td>0</td><td>0</td><td>0</td><td>0</td><td>0</td> </tr> </table>	0	1	0	1	0	0	0	0	1	0	0	0	0	0	0	0
0	1	0	1	0	0	0	0										
1	0	0	0	0	0	0	0										
Machine Cycle:	1																
Operation:	Disable interrupt function																
Description:	Interrupt function is inhibited by executing this instruction.																
<b>DSKNZ R</b>	<b>Decrement R contents then skip if ACC != 0</b>																
Machine Code:	<table border="1" style="display: inline-table; margin-right: 20px;"> <tr> <td>0</td><td>1</td><td>0</td><td>0</td><td>1</td><td>0</td><td>0</td><td>0</td> </tr> </table> <table border="1" style="display: inline-table;"> <tr> <td>1</td><td>R6</td><td>R5</td><td>R4</td><td>R3</td><td>R2</td><td>R1</td><td>R0</td> </tr> </table>	0	1	0	0	1	0	0	0	1	R6	R5	R4	R3	R2	R1	R0
0	1	0	0	1	0	0	0										
1	R6	R5	R4	R3	R2	R1	R0										
Machine Cycle:	1																
Operation:	ACC, R ← (R) - 1; PC ← (PC) + 2 if ACC != 0																
Description:	Decrement the data memory contents and load result into the ACC and the data memory. If ACC != 0, the program counter is incremented by 2 and produces a skip.																
Flag Affected:	CF & ZF																



Instruction Set Table 2, continued

<b>DSKZ R</b>	<b>Decrement R contents then skip if ACC is zero</b>																
Machine Code:	<table border="1" style="display: inline-table; margin-right: 20px;"> <tr> <td>0</td><td>1</td><td>0</td><td>0</td><td>1</td><td>0</td><td>0</td><td>0</td> </tr> </table> <table border="1" style="display: inline-table;"> <tr> <td>0</td><td>R6</td><td>R5</td><td>R4</td><td>R3</td><td>R2</td><td>R1</td><td>R0</td> </tr> </table>	0	1	0	0	1	0	0	0	0	R6	R5	R4	R3	R2	R1	R0
0	1	0	0	1	0	0	0										
0	R6	R5	R4	R3	R2	R1	R0										
Machine Cycle:	1																
Operation:	$ACC, R \leftarrow (R) - 1;$ $PC \leftarrow (PC) + 2$ if $ACC = 0$																
Description:	Decrement the data memory contents and load result into the ACC and the data memory. If $ACC = 0$ , the program counter is incremented by 2 and produces a skip.																
Flag Affected:	CF & ZF																
<b>EN INT</b>	<b>Enable Interrupt function</b>																
Machine Code:	<table border="1" style="display: inline-table; margin-right: 20px;"> <tr> <td>0</td><td>1</td><td>0</td><td>1</td><td>0</td><td>0</td><td>0</td><td>0</td> </tr> </table> <table border="1" style="display: inline-table;"> <tr> <td>1</td><td>1</td><td>0</td><td>0</td><td>0</td><td>0</td><td>0</td><td>0</td> </tr> </table>	0	1	0	1	0	0	0	0	1	1	0	0	0	0	0	0
0	1	0	1	0	0	0	0										
1	1	0	0	0	0	0	0										
Machine Cycle:	1																
Operation:	Enable interrupt function																
Description:	This instruction enables the interrupt function.																
<b>HOLD</b>	<b>Enter the HOLD mode</b>																
Machine Code:	<table border="1" style="display: inline-table; margin-right: 20px;"> <tr> <td>0</td><td>0</td><td>0</td><td>0</td><td>0</td><td>0</td><td>0</td><td>0</td> </tr> </table> <table border="1" style="display: inline-table;"> <tr> <td>1</td><td>0</td><td>0</td><td>0</td><td>0</td><td>0</td><td>0</td><td>0</td> </tr> </table>	0	0	0	0	0	0	0	0	1	0	0	0	0	0	0	0
0	0	0	0	0	0	0	0										
1	0	0	0	0	0	0	0										
Machine Cycle:	1																
Operation:	Enter the HOLD mode																
Description:	<p>The following two conditions cause the HOLD mode to be released.</p> <p>(1) An interrupt is accepted.</p> <p>(2) The HOLD release condition specified by the HEF is met.</p> <p>In HOLD mode, when an interrupt is accepted the HOLD mode will be released and the interrupt service routine will be executed. After completing the interrupt service routine by executing the RTN instruction, the <math>\mu C</math> will enter HOLD mode again.</p>																



Instruction Set Table 2, continued

<b>INC R</b>	<b>Increment R contents</b>																
Machine Code:	<table border="1" style="display: inline-table; margin-right: 20px;"> <tr> <td>0</td><td>1</td><td>0</td><td>0</td><td>1</td><td>0</td><td>1</td><td>0</td> </tr> </table> <table border="1" style="display: inline-table;"> <tr> <td>0</td><td>R6</td><td>R5</td><td>R4</td><td>R3</td><td>R2</td><td>R1</td><td>R0</td> </tr> </table>	0	1	0	0	1	0	1	0	0	R6	R5	R4	R3	R2	R1	R0
0	1	0	0	1	0	1	0										
0	R6	R5	R4	R3	R2	R1	R0										
Machine Cycle:	1																
Operation:	ACC, R ← (R) + 1																
Description:	Increment the data memory contents and load the result into the ACC and the data memory.																
Flag Affected:	CF & ZF																
<b>JB0 L</b>	<b>Jump when bit 0 of ACC is "1"</b>																
Machine Code:	<table border="1" style="display: inline-table; margin-right: 20px;"> <tr> <td>1</td><td>0</td><td>0</td><td>0</td><td>0</td><td>L10</td><td>L9</td><td>L8</td> </tr> </table> <table border="1" style="display: inline-table;"> <tr> <td>L7</td><td>L6</td><td>L5</td><td>L4</td><td>L3</td><td>L2</td><td>L1</td><td>L0</td> </tr> </table>	1	0	0	0	0	L10	L9	L8	L7	L6	L5	L4	L3	L2	L1	L0
1	0	0	0	0	L10	L9	L8										
L7	L6	L5	L4	L3	L2	L1	L0										
Machine Cycle:	1																
Operation:	PC10–PC0 ← L10–L0; if ACC.0 = "1"																
Description:	If bit 0 of the ACC is "1," PC10 to PC0 of the program counter are replaced with the data specified by L10 to L0 and a jump occurs. If bit 0 of the ACC is "0," the program counter (PC) is incremented.																
<b>JB1 L</b>	<b>Jump when bit 1 of ACC is "1"</b>																
Machine Code:	<table border="1" style="display: inline-table; margin-right: 20px;"> <tr> <td>1</td><td>0</td><td>0</td><td>1</td><td>0</td><td>L10</td><td>L9</td><td>L8</td> </tr> </table> <table border="1" style="display: inline-table;"> <tr> <td>L7</td><td>L6</td><td>L5</td><td>L4</td><td>L3</td><td>L2</td><td>L1</td><td>L0</td> </tr> </table>	1	0	0	1	0	L10	L9	L8	L7	L6	L5	L4	L3	L2	L1	L0
1	0	0	1	0	L10	L9	L8										
L7	L6	L5	L4	L3	L2	L1	L0										
Machine Cycle:	1																
Operation:	PC10–PC0 ← L10–L0; if ACC.1 = "1"																
Description:	If bit 1 of the ACC is "1," PC10 to PC0 of the program counter are replaced with the data specified by L10 to L0 and a jump occurs. If bit 1 of the ACC is "0," the program counter (PC) is incremented.																



Instruction Set Table 2, continued

<b>JB2</b> <b>L</b>	<b>Jump when bit 2 of ACC is "1"</b>																
Machine Code:	<table border="1" style="display: inline-table; margin-right: 20px;"> <tr> <td>1</td><td>0</td><td>1</td><td>0</td><td>0</td><td>L10</td><td>L9</td><td>L8</td> </tr> </table> <table border="1" style="display: inline-table;"> <tr> <td>L7</td><td>L6</td><td>L5</td><td>L4</td><td>L3</td><td>L2</td><td>L1</td><td>L0</td> </tr> </table>	1	0	1	0	0	L10	L9	L8	L7	L6	L5	L4	L3	L2	L1	L0
1	0	1	0	0	L10	L9	L8										
L7	L6	L5	L4	L3	L2	L1	L0										
Machine Cycle:	1																
Operation:	$PC_{10-PC0} \leftarrow L_{10-L0}$ ; if ACC.2 = "1"																
Description:	If bit 2 of the ACC is "1," PC10 to PC0 of the program counter are replaced with the data specified by L10 to L0 and a jump occurs. If bit 2 of the ACC is "0," the program counter (PC) is incremented.																
<b>JB3</b> <b>L</b>	<b>Jump when bit 3 of ACC is "1"</b>																
Machine Code:	<table border="1" style="display: inline-table; margin-right: 20px;"> <tr> <td>1</td><td>0</td><td>1</td><td>1</td><td>0</td><td>L10</td><td>L9</td><td>L8</td> </tr> </table> <table border="1" style="display: inline-table;"> <tr> <td>L7</td><td>L6</td><td>L5</td><td>L4</td><td>L3</td><td>L2</td><td>L1</td><td>L0</td> </tr> </table>	1	0	1	1	0	L10	L9	L8	L7	L6	L5	L4	L3	L2	L1	L0
1	0	1	1	0	L10	L9	L8										
L7	L6	L5	L4	L3	L2	L1	L0										
Machine Cycle:	1																
Operation:	$PC_{10-PC0} \leftarrow L_{10-L0}$ ; if ACC.3 = "1"																
Description:	If bit 3 of the ACC is "1," PC10 to PC0 of the program counter are replaced with the data specified by L10 to L0 and a jump occurs. If bit 3 of the ACC is "0," the program counter (PC) is incremented.																
<b>JC</b> <b>L</b>	<b>Jump when CF is "1"</b>																
Machine Code:	<table border="1" style="display: inline-table; margin-right: 20px;"> <tr> <td>1</td><td>1</td><td>1</td><td>1</td><td>0</td><td>L10</td><td>L9</td><td>L8</td> </tr> </table> <table border="1" style="display: inline-table;"> <tr> <td>L7</td><td>L6</td><td>L5</td><td>L4</td><td>L3</td><td>L2</td><td>L1</td><td>L0</td> </tr> </table>	1	1	1	1	0	L10	L9	L8	L7	L6	L5	L4	L3	L2	L1	L0
1	1	1	1	0	L10	L9	L8										
L7	L6	L5	L4	L3	L2	L1	L0										
Machine Cycle:	1																
Operation:	$PC_{10-PC0} \leftarrow L_{10-L0}$ ; if CF = "1"																
Description:	If CF is "1," PC10 to PC0 of the program counter are replaced with the data specified by L10 to L0 and a jump occurs. If the CF is "0," the program counter (PC) is incremented.																



Instruction Set Table 2, continued

<b>JMP</b> <b>L</b>	<b>Jump absolutely</b>																
Machine Code:	<table border="1"> <tr> <td>0</td><td>1</td><td>1</td><td>1</td><td>0</td><td>L10</td><td>L9</td><td>L8</td> <td>L7</td><td>L6</td><td>L5</td><td>L4</td><td>L3</td><td>L2</td><td>L1</td><td>L0</td> </tr> </table>	0	1	1	1	0	L10	L9	L8	L7	L6	L5	L4	L3	L2	L1	L0
0	1	1	1	0	L10	L9	L8	L7	L6	L5	L4	L3	L2	L1	L0		
Machine Cycle:	1																
Operation:	PC10-PC0 ← L10-L0																
Description:	PC10 to PC0 of the program counter are replaced with the data specified by L10 to L0 and an unconditional jump occurs.																
<b>JNC</b> <b>L</b>	<b>Jump when CF is not "1"</b>																
Machine Code:	<table border="1"> <tr> <td>1</td><td>1</td><td>0</td><td>1</td><td>0</td><td>L10</td><td>L9</td><td>L8</td> <td>L7</td><td>L6</td><td>L5</td><td>L4</td><td>L3</td><td>L2</td><td>L1</td><td>L0</td> </tr> </table>	1	1	0	1	0	L10	L9	L8	L7	L6	L5	L4	L3	L2	L1	L0
1	1	0	1	0	L10	L9	L8	L7	L6	L5	L4	L3	L2	L1	L0		
Machine Cycle:	1																
Operation:	PC10-PC0 ← L10-L0; if CF = "0"																
Description:	If CF is "0," PC10 to PC0 of the program counter are replaced with the data specified by L10 to L0 and a jump occurs. If CF is "1," the program counter (PC) is incremented.																
<b>JNZ</b> <b>L</b>	<b>Jump when ACC is not zero</b>																
Machine Code:	<table border="1"> <tr> <td>1</td><td>1</td><td>0</td><td>0</td><td>0</td><td>L10</td><td>L9</td><td>L8</td> <td>L7</td><td>L6</td><td>L5</td><td>L4</td><td>L3</td><td>L2</td><td>L1</td><td>L0</td> </tr> </table>	1	1	0	0	0	L10	L9	L8	L7	L6	L5	L4	L3	L2	L1	L0
1	1	0	0	0	L10	L9	L8	L7	L6	L5	L4	L3	L2	L1	L0		
Machine Cycle:	1																
Operation:	PC10-PC0 ← L10-L0; if ACC != 0																
Description:	If the ACC is not zero, PC10 to PC0 of the program counter are replaced with the data specified by L10 to L0 and a jump occurs. If the ACC is zero, the program counter (PC) is incremented.																



Instruction Set Table 2, continued

<b>JZ</b> <b>L</b>	<b>Jump when ACC is zero</b>	
Machine Code:	1 1 1 0 0 L10 L9 L8	L7 L6 L5 L4 L3 L2 L1 L0
Machine Cycle:	1	
Operation:	PC10-PC0 ← L10-L0; if ACC = 0	
Description:	If the ACC is zero, PC10 to PC0 of the program counter are replaced with the data specified by L10 to L0 and a jump occurs. If the ACC is not zero, the program counter (PC) is incremented.	
<b>LCDON</b>	<b>LCD ON</b>	
Machine Code:	0 0 0 0 0 0 1 0	0 0 0 0 0 0 0 0
Machine Cycle:	1	
Operation:	LCD ON	
Description:	Turn on LCD display.	
<b>LCDOFF</b>	<b>LCD OFF</b>	
Machine Code:	0 0 0 0 0 0 1 0	1 0 0 0 0 0 0 0
Machine Cycle:	1	
Operation:	LCD OFF	
Description:	Turn off LCD display.	



Instruction Set Table 2, continued

<b>MOV ACC, R</b>	<b>Move R content to ACC</b>																
Machine Code:	<table border="1" style="display: inline-table; margin-right: 20px;"> <tr> <td>0</td><td>1</td><td>0</td><td>0</td><td>1</td><td>1</td><td>1</td><td>0</td> </tr> </table> <table border="1" style="display: inline-table;"> <tr> <td>1</td><td>R6</td><td>R5</td><td>R4</td><td>R3</td><td>R2</td><td>R1</td><td>R0</td> </tr> </table>	0	1	0	0	1	1	1	0	1	R6	R5	R4	R3	R2	R1	R0
0	1	0	0	1	1	1	0										
1	R6	R5	R4	R3	R2	R1	R0										
Machine Cycle:	1																
Operation:	ACC ← (R)																
Description:	The contents of the data memory location addressed by R6 to R0 are loaded into the ACC.																
Flag Affected:	ZF																
<b>MOV CF, R</b>	<b>Move R.0 content to CF</b>																
Machine Code:	<table border="1" style="display: inline-table; margin-right: 20px;"> <tr> <td>0</td><td>1</td><td>0</td><td>1</td><td>1</td><td>0</td><td>0</td><td>0</td> </tr> </table> <table border="1" style="display: inline-table;"> <tr> <td>0</td><td>R6</td><td>R5</td><td>R4</td><td>R3</td><td>R2</td><td>R1</td><td>R0</td> </tr> </table>	0	1	0	1	1	0	0	0	0	R6	R5	R4	R3	R2	R1	R0
0	1	0	1	1	0	0	0										
0	R6	R5	R4	R3	R2	R1	R0										
Machine Cycle:	1																
Operation:	CF ← (R.0)																
Description:	The bit 0 content of the data memory location addressed by R6 to R0 is loaded into CF.																
Flag Affected:	CF																



Instruction Set Table 2, continued

MOV HEF, #I	Set/Reset Hold mode release Enable Flag																
Machine Code:	<table border="1" style="display: inline-table; border-collapse: collapse;"> <tr> <td style="padding: 2px 5px;">0</td><td style="padding: 2px 5px;">1</td><td style="padding: 2px 5px;">0</td><td style="padding: 2px 5px;">0</td><td style="padding: 2px 5px;">0</td><td style="padding: 2px 5px;">0</td><td style="padding: 2px 5px;">0</td><td style="padding: 2px 5px;">1</td> </tr> </table> <table border="1" style="display: inline-table; border-collapse: collapse; margin-left: 20px;"> <tr> <td style="padding: 2px 5px;">17</td><td style="padding: 2px 5px;">16</td><td style="padding: 2px 5px;">15</td><td style="padding: 2px 5px;">14</td><td style="padding: 2px 5px;">13</td><td style="padding: 2px 5px;">12</td><td style="padding: 2px 5px;">11</td><td style="padding: 2px 5px;">10</td> </tr> </table>	0	1	0	0	0	0	0	1	17	16	15	14	13	12	11	10
0	1	0	0	0	0	0	1										
17	16	15	14	13	12	11	10										
Machine Cycle:	1																
Operation:	Hold mode release enable flag control																
Description:	<table border="1" style="width: 100%; border-collapse: collapse;"> <thead> <tr> <th style="width: 15%;">I0 to I7</th> <th>Operation</th> </tr> </thead> <tbody> <tr> <td>I0 = 1</td> <td>HEF0 is set so that overflow from Divider0 will caused the HOLD mode to be released.</td> </tr> <tr> <td>I1 = 1</td> <td>HEF1 is set so that underflow from Timer 0 will caused the HOLD mode to be released.</td> </tr> <tr> <td>I2 = 1</td> <td>HEF2 is set so that signal change on port RC caused the HOLD mode to be released.</td> </tr> <tr> <td>I3 = 1</td> <td>Reserved</td> </tr> <tr> <td>I4 = 1</td> <td>HEF4 is set so that overflow from Divider1 will caused the HOLD mode to be released.</td> </tr> <tr> <td>I5 &amp; I6</td> <td>Reserved</td> </tr> <tr> <td>I7 = 1</td> <td>HEF7 is set so that underflow from Timer 1 will caused the HOLD mode to be released.</td> </tr> </tbody> </table>	I0 to I7	Operation	I0 = 1	HEF0 is set so that overflow from Divider0 will caused the HOLD mode to be released.	I1 = 1	HEF1 is set so that underflow from Timer 0 will caused the HOLD mode to be released.	I2 = 1	HEF2 is set so that signal change on port RC caused the HOLD mode to be released.	I3 = 1	Reserved	I4 = 1	HEF4 is set so that overflow from Divider1 will caused the HOLD mode to be released.	I5 & I6	Reserved	I7 = 1	HEF7 is set so that underflow from Timer 1 will caused the HOLD mode to be released.
I0 to I7	Operation																
I0 = 1	HEF0 is set so that overflow from Divider0 will caused the HOLD mode to be released.																
I1 = 1	HEF1 is set so that underflow from Timer 0 will caused the HOLD mode to be released.																
I2 = 1	HEF2 is set so that signal change on port RC caused the HOLD mode to be released.																
I3 = 1	Reserved																
I4 = 1	HEF4 is set so that overflow from Divider1 will caused the HOLD mode to be released.																
I5 & I6	Reserved																
I7 = 1	HEF7 is set so that underflow from Timer 1 will caused the HOLD mode to be released.																



Instruction Set Table 2, continued

MOV IEF, #I	Set/Reset Interrupt Enable Flag																
Machine Code:	<table border="1"> <tr> <td>0 1 0 1 0 0 0 1</td> <td>17 16 15 14 13 12 11 10</td> </tr> </table>	0 1 0 1 0 0 0 1	17 16 15 14 13 12 11 10														
0 1 0 1 0 0 0 1	17 16 15 14 13 12 11 10																
Machine Cycle:	1																
Operation:	Interrupt Enable flag Control																
Description:	<p>The interrupt enable flag corresponding to the data specified by I7–I0 is controlled:</p> <table border="1"> <tr> <th>I0 to I5</th> <th>Operation</th> </tr> <tr> <td>I0 = 1</td> <td>The IEF0 is set so that interrupt 0 (overflow from the Divider0) is accepted.</td> </tr> <tr> <td>I1 = 1</td> <td>The IEF1 is set so that interrupt 1 (underflow from the Timer 0) is accepted.</td> </tr> <tr> <td>I2 = 1</td> <td>The IEF2 is set so that interrupt 2 (signal change on port RC) is accepted.</td> </tr> <tr> <td>I3 = 1</td> <td>Reserved</td> </tr> <tr> <td>I4 = 1</td> <td>The IEF4 is set so that interrupt 4 (overflow from the Divider1) is accepted.</td> </tr> <tr> <td>I5 &amp; I6</td> <td>Reserved</td> </tr> <tr> <td>I7 = 1</td> <td>The IEF7 is set so that interrupt 7 (underflow from the Timer 1) is accepted.</td> </tr> </table>	I0 to I5	Operation	I0 = 1	The IEF0 is set so that interrupt 0 (overflow from the Divider0) is accepted.	I1 = 1	The IEF1 is set so that interrupt 1 (underflow from the Timer 0) is accepted.	I2 = 1	The IEF2 is set so that interrupt 2 (signal change on port RC) is accepted.	I3 = 1	Reserved	I4 = 1	The IEF4 is set so that interrupt 4 (overflow from the Divider1) is accepted.	I5 & I6	Reserved	I7 = 1	The IEF7 is set so that interrupt 7 (underflow from the Timer 1) is accepted.
I0 to I5	Operation																
I0 = 1	The IEF0 is set so that interrupt 0 (overflow from the Divider0) is accepted.																
I1 = 1	The IEF1 is set so that interrupt 1 (underflow from the Timer 0) is accepted.																
I2 = 1	The IEF2 is set so that interrupt 2 (signal change on port RC) is accepted.																
I3 = 1	Reserved																
I4 = 1	The IEF4 is set so that interrupt 4 (overflow from the Divider1) is accepted.																
I5 & I6	Reserved																
I7 = 1	The IEF7 is set so that interrupt 7 (underflow from the Timer 1) is accepted.																
MOV LCDM, #I	Select LCD output Mode type																
Machine Code:	<table border="1"> <tr> <td>0 0 0 0 0 0 1 1</td> <td>17 16 15 14 13 12 11 10</td> </tr> </table>	0 0 0 0 0 0 1 1	17 16 15 14 13 12 11 10														
0 0 0 0 0 0 1 1	17 16 15 14 13 12 11 10																
Machine Cycle:	1																
Operation:	Select LCD output mode type																
Description:	<p>When LCD output pins are set to DC output mode, user can select CMOS or NMOS as output type.</p> <p>I0–I7 = 0 =&gt; CMOS type; I0–I7 = 1 =&gt; NMOS type</p>																



Instruction Set Table 2, continued

<b>MOV LCDR, ACC</b>	<b>Move ACC content to LCDR</b>		
Machine Code:	<table border="1" style="display: inline-table; border-collapse: collapse;"> <tr> <td style="padding: 2px 5px;">0 0 0 0 0 1 1 D4</td> <td style="padding: 2px 5px;">D3 D2 D1 D0 0 0 0 0</td> </tr> </table>	0 0 0 0 0 1 1 D4	D3 D2 D1 D0 0 0 0 0
0 0 0 0 0 1 1 D4	D3 D2 D1 D0 0 0 0 0		
Machine Cycle:	1		
Operation:	LCDR ← (ACC)		
Description:	The contents of the ACC are loaded to the LCD data RAM (LCDR) location addressed by D4 to D0.		
<b>MOV LCDR, WR</b>	<b>Load WR content to LCDR</b>		
Machine Code:	<table border="1" style="display: inline-table; border-collapse: collapse;"> <tr> <td style="padding: 2px 5px;">0 1 0 0 0 1 0 D4</td> <td style="padding: 2px 5px;">D3 D2 D1 D0 W3 W2 W1 W0</td> </tr> </table>	0 1 0 0 0 1 0 D4	D3 D2 D1 D0 W3 W2 W1 W0
0 1 0 0 0 1 0 D4	D3 D2 D1 D0 W3 W2 W1 W0		
Machine Cycle:	1		
Operation:	LCDR ← (WR)		
Description:	The contents of the WR are loaded to the LCD data RAM (LCDR) location addressed by D4 to D0.		
<b>MOV LCDR, #I</b>	<b>Load immediate data to LCDR</b>		
Machine Code:	<table border="1" style="display: inline-table; border-collapse: collapse;"> <tr> <td style="padding: 2px 5px;">0 0 0 0 0 1 0 D4</td> <td style="padding: 2px 5px;">D3 D2 D1 D0 I3 I2 I1 I0</td> </tr> </table>	0 0 0 0 0 1 0 D4	D3 D2 D1 D0 I3 I2 I1 I0
0 0 0 0 0 1 0 D4	D3 D2 D1 D0 I3 I2 I1 I0		
Machine Cycle:	1		
Operation:	LCDR ← I		
Description:	The immediate data I are loaded to the LCD data RAM (LCDR) location addressed by D4 to D0.		



Instruction Set Table 2, continued

<b>MOV MFP, #I</b>	<b>Modulation Frequency Pulse generator</b>																													
Machine Code:	<table border="1" style="display: inline-table; margin-right: 20px;"> <tr> <td>0</td><td>0</td><td>0</td><td>1</td><td>0</td><td>0</td><td>1</td><td>0</td> </tr> </table> <table border="1" style="display: inline-table;"> <tr> <td>17</td><td>16</td><td>15</td><td>14</td><td>13</td><td>12</td><td>11</td><td>10</td> </tr> </table>	0	0	0	1	0	0	1	0	17	16	15	14	13	12	11	10													
0	0	0	1	0	0	1	0																							
17	16	15	14	13	12	11	10																							
Machine Cycle:	1																													
Operation:	[MFP] ← I																													
Description:	<p>If the bit 2 of MR1 is "0," the waveform specified by I7 to I0 is delivered at the MFP output pin (MFP). The relationship between the waveform and immediate data I is as follows:</p> <table border="1" style="margin: 10px auto;"> <thead> <tr> <th>I5~I0</th> <th>I0 = 1</th> <th>I1 = 1</th> <th>I2 = 1</th> <th>I3 = 1</th> <th>I4 = 1</th> <th>I5 = 1</th> </tr> </thead> <tbody> <tr> <td>Signal</td> <td><math>\frac{F_{osc}}{256}</math></td> <td><math>\frac{F_{osc}}{512}</math></td> <td><math>\frac{F_{osc}}{4096}</math></td> <td><math>\frac{F_{osc}}{8192}</math></td> <td><math>\frac{F_{osc}}{16384}</math></td> <td><math>\frac{F_{osc}}{32768}</math></td> </tr> </tbody> </table> <table border="1" style="margin: 10px auto;"> <thead> <tr> <th>I7</th> <th>I6</th> <th>Signal</th> </tr> </thead> <tbody> <tr> <td>0</td> <td>0</td> <td>Low</td> </tr> <tr> <td>0</td> <td>1</td> <td>High</td> </tr> <tr> <td>1</td> <td>0</td> <td>Fosc/16</td> </tr> <tr> <td>1</td> <td>1</td> <td>Fosc/8</td> </tr> </tbody> </table>	I5~I0	I0 = 1	I1 = 1	I2 = 1	I3 = 1	I4 = 1	I5 = 1	Signal	$\frac{F_{osc}}{256}$	$\frac{F_{osc}}{512}$	$\frac{F_{osc}}{4096}$	$\frac{F_{osc}}{8192}$	$\frac{F_{osc}}{16384}$	$\frac{F_{osc}}{32768}$	I7	I6	Signal	0	0	Low	0	1	High	1	0	Fosc/16	1	1	Fosc/8
I5~I0	I0 = 1	I1 = 1	I2 = 1	I3 = 1	I4 = 1	I5 = 1																								
Signal	$\frac{F_{osc}}{256}$	$\frac{F_{osc}}{512}$	$\frac{F_{osc}}{4096}$	$\frac{F_{osc}}{8192}$	$\frac{F_{osc}}{16384}$	$\frac{F_{osc}}{32768}$																								
I7	I6	Signal																												
0	0	Low																												
0	1	High																												
1	0	Fosc/16																												
1	1	Fosc/8																												



Instruction Set Table 2, continued

<b>MOV MR0, #I</b>	<b>Load immediate data to Mode Register 0 (MR0)</b>								
Machine Code:	<table border="1"> <tr> <td>0 0 0 1 0 0 1 1</td> <td>1 0 0 0 13 12 11 10</td> </tr> </table>	0 0 0 1 0 0 1 1	1 0 0 0 13 12 11 10						
0 0 0 1 0 0 1 1	1 0 0 0 13 12 11 10								
Machine Cycle:	1								
Operation:	MR0 ← I								
Description:	<p>The immediate data I are loaded to the MR0.</p> <p>MR0 bits description:</p> <table border="1"> <tr> <td>bit 0</td> <td>= 0 The fundamental frequency of Timer 0 is Fosc/4 = 1 The fundamental frequency of Timer 0 is Fosc/1024</td> </tr> <tr> <td>bit 1</td> <td>Reserved</td> </tr> <tr> <td>bit 2</td> <td>Reserved</td> </tr> <tr> <td>bit 3</td> <td>= 0 Timer 0 stop down-counting = 1 Timer 0 start down-counting</td> </tr> </table>	bit 0	= 0 The fundamental frequency of Timer 0 is Fosc/4 = 1 The fundamental frequency of Timer 0 is Fosc/1024	bit 1	Reserved	bit 2	Reserved	bit 3	= 0 Timer 0 stop down-counting = 1 Timer 0 start down-counting
bit 0	= 0 The fundamental frequency of Timer 0 is Fosc/4 = 1 The fundamental frequency of Timer 0 is Fosc/1024								
bit 1	Reserved								
bit 2	Reserved								
bit 3	= 0 Timer 0 stop down-counting = 1 Timer 0 start down-counting								
<b>MOV MR1, #I</b>	<b>Load immediate data to Mode Register 1 (MR1)</b>								
Machine Code:	<table border="1"> <tr> <td>0 0 0 1 0 0 1 1</td> <td>0 0 0 0 13 12 11 10</td> </tr> </table>	0 0 0 1 0 0 1 1	0 0 0 0 13 12 11 10						
0 0 0 1 0 0 1 1	0 0 0 0 13 12 11 10								
Machine Cycle:	1								
Operation:	MR1 ← I								
Description:	<p>The immediate data I are loaded to the MR1.</p> <p>MR1 bit description:</p> <table border="1"> <tr> <td>bit0</td> <td>= 0 The internal fundamental frequency of Timer 1 is Fosc = 1 The internal fundamental frequency of Timer 1 is Fosc/64</td> </tr> <tr> <td>bit1</td> <td>= 0 The fundamental frequency source of Timer 1 is internal clock = 1 The fundamental frequency source of Timer 1 is external clock via RC.0 input pin</td> </tr> <tr> <td>bit2</td> <td>= 0 The specified waveform of the MFP generator is delivered at the MFP output pin = 1 The specified frequency of the Timer 1 is delivered at the MFP output pin</td> </tr> <tr> <td>bit3</td> <td>= 0 Timer 1 stop down-counting = 1 Timer 1 start down-counting</td> </tr> </table>	bit0	= 0 The internal fundamental frequency of Timer 1 is Fosc = 1 The internal fundamental frequency of Timer 1 is Fosc/64	bit1	= 0 The fundamental frequency source of Timer 1 is internal clock = 1 The fundamental frequency source of Timer 1 is external clock via RC.0 input pin	bit2	= 0 The specified waveform of the MFP generator is delivered at the MFP output pin = 1 The specified frequency of the Timer 1 is delivered at the MFP output pin	bit3	= 0 Timer 1 stop down-counting = 1 Timer 1 start down-counting
bit0	= 0 The internal fundamental frequency of Timer 1 is Fosc = 1 The internal fundamental frequency of Timer 1 is Fosc/64								
bit1	= 0 The fundamental frequency source of Timer 1 is internal clock = 1 The fundamental frequency source of Timer 1 is external clock via RC.0 input pin								
bit2	= 0 The specified waveform of the MFP generator is delivered at the MFP output pin = 1 The specified frequency of the Timer 1 is delivered at the MFP output pin								
bit3	= 0 Timer 1 stop down-counting = 1 Timer 1 start down-counting								



Instruction Set Table 2, continued

<b>MOV PAGE, #I</b>	<b>Load immediate data to Page Register</b>																																				
Machine Code:	<table border="1"> <tr> <td>0</td><td>1</td><td>0</td><td>1</td><td>0</td><td>1</td><td>1</td><td>0</td> <td>1</td><td>0</td><td>0</td><td>0</td><td>I3</td><td>I2</td><td>I1</td><td>I0</td> </tr> </table>	0	1	0	1	0	1	1	0	1	0	0	0	I3	I2	I1	I0																				
0	1	0	1	0	1	1	0	1	0	0	0	I3	I2	I1	I0																						
Machine Cycle:	1																																				
Operation:	Page Register ← I																																				
Description:	<p>The immediate data I are loaded to the PR.                      Bit 3 is reserved.                      Bit 0, bit 1, and bit 2 indirect addressing mode preselect bits:</p> <table border="1"> <thead> <tr> <th>bit2</th> <th>bit1</th> <th>bit0</th> <th></th> </tr> </thead> <tbody> <tr> <td>0</td> <td>0</td> <td>0</td> <td>= Page 0 (00H to 0FH)</td> </tr> <tr> <td>0</td> <td>0</td> <td>1</td> <td>= Page 1 (10H to 1FH)</td> </tr> <tr> <td>0</td> <td>1</td> <td>0</td> <td>= Page 2 (20H to 2FH)</td> </tr> <tr> <td>0</td> <td>1</td> <td>1</td> <td>= Page 3 (30H to 3FH)</td> </tr> <tr> <td>1</td> <td>0</td> <td>0</td> <td>= Page 4 (40H to 4FH)</td> </tr> <tr> <td>1</td> <td>0</td> <td>1</td> <td>= Page 5 (50H to 5FH)</td> </tr> <tr> <td>1</td> <td>1</td> <td>0</td> <td>= Page 6 (60H to 6FH)</td> </tr> <tr> <td>1</td> <td>1</td> <td>1</td> <td>= Page 7 (70H to 7FH)</td> </tr> </tbody> </table>	bit2	bit1	bit0		0	0	0	= Page 0 (00H to 0FH)	0	0	1	= Page 1 (10H to 1FH)	0	1	0	= Page 2 (20H to 2FH)	0	1	1	= Page 3 (30H to 3FH)	1	0	0	= Page 4 (40H to 4FH)	1	0	1	= Page 5 (50H to 5FH)	1	1	0	= Page 6 (60H to 6FH)	1	1	1	= Page 7 (70H to 7FH)
bit2	bit1	bit0																																			
0	0	0	= Page 0 (00H to 0FH)																																		
0	0	1	= Page 1 (10H to 1FH)																																		
0	1	0	= Page 2 (20H to 2FH)																																		
0	1	1	= Page 3 (30H to 3FH)																																		
1	0	0	= Page 4 (40H to 4FH)																																		
1	0	1	= Page 5 (50H to 5FH)																																		
1	1	0	= Page 6 (60H to 6FH)																																		
1	1	1	= Page 7 (70H to 7FH)																																		
<b>MOV PEF, #I</b>	<b>Set/Reset Port Enable Flag</b>																																				
Machine Code:	<table border="1"> <tr> <td>0</td><td>1</td><td>0</td><td>0</td><td>0</td><td>0</td><td>1</td><td>1</td> <td>0</td><td>0</td><td>0</td><td>0</td><td>I3</td><td>I2</td><td>I1</td><td>I0</td> </tr> </table>	0	1	0	0	0	0	1	1	0	0	0	0	I3	I2	I1	I0																				
0	1	0	0	0	0	1	1	0	0	0	0	I3	I2	I1	I0																						
Machine Cycle:	1																																				
Operation:	Port enable flag control																																				
Description:	<p>The data specified by I can cause HOLD mode to be released or an interrupt to occur. The signal change on port RC is specified.</p> <table border="1"> <thead> <tr> <th>I0 to I3</th> <th>Signal change at port RC</th> </tr> </thead> <tbody> <tr> <td>I0 = 1</td> <td>RC0</td> </tr> <tr> <td>I1 = 1</td> <td>RC1</td> </tr> <tr> <td>I2 = 1</td> <td>RC2</td> </tr> <tr> <td>I3 = 1</td> <td>RC3</td> </tr> </tbody> </table>	I0 to I3	Signal change at port RC	I0 = 1	RC0	I1 = 1	RC1	I2 = 1	RC2	I3 = 1	RC3																										
I0 to I3	Signal change at port RC																																				
I0 = 1	RC0																																				
I1 = 1	RC1																																				
I2 = 1	RC2																																				
I3 = 1	RC3																																				



Instruction Set Table 2, continued

<b>MOV PM0, #I</b>	<b>Set/Reset Port Mode 0 register</b>																
Machine Code:	<table border="1" style="display: inline-table; margin-right: 20px;"> <tr> <td>0</td><td>1</td><td>0</td><td>1</td><td>0</td><td>0</td><td>1</td><td>1</td> </tr> </table> <table border="1" style="display: inline-table;"> <tr> <td>0</td><td>0</td><td>0</td><td>0</td><td>I3</td><td>I2</td><td>I1</td><td>I0</td> </tr> </table>	0	1	0	1	0	0	1	1	0	0	0	0	I3	I2	I1	I0
0	1	0	1	0	0	1	1										
0	0	0	0	I3	I2	I1	I0										
Machine Cycle:	1																
Operation:	Set/Reset Port mode 0 register																
Description:	<p>I0 = 0: RA port is CMOS type; I0 = 1: RA port is NMOS type.                      I1 = 0: RB port is CMOS type; I1 = 1: RB port is NMOS type.                      I2 = 0: RC port pull-high resistor is disabled;                      I2 = 1: RC port pull-high resistor is enabled.                      I3 = 0: RD port pull-high resistor is disabled;                      I3 = 1: RD port pull-high resistor is enabled.</p>																
<b>MOV PM1, #I</b>	<b>RA port independent Input/Output control</b>																
Machine Code:	<table border="1" style="display: inline-table; margin-right: 20px;"> <tr> <td>0</td><td>1</td><td>0</td><td>1</td><td>0</td><td>1</td><td>1</td><td>1</td> </tr> </table> <table border="1" style="display: inline-table;"> <tr> <td>0</td><td>0</td><td>0</td><td>0</td><td>I3</td><td>I2</td><td>I1</td><td>I0</td> </tr> </table>	0	1	0	1	0	1	1	1	0	0	0	0	I3	I2	I1	I0
0	1	0	1	0	1	1	1										
0	0	0	0	I3	I2	I1	I0										
Machine Cycle:	1																
Operation:	Input/output control of 4 RA port pins is independent.																
Description:	<p>I0 = 0: RA.0 is output pin; I0 = 1: RA.0 is input pin.                      I1 = 0: RA.1 is output pin; I1 = 1: RA.1 is input pin.                      I2 = 0: RA.2 is output pin; I2 = 1: RA.2 is input pin.                      I3 = 0: RA.3 is output pin; I3 = 1: RA.3 is input pin.                      Default condition RA port is input mode (PM = 1111B).</p>																



Instruction set table 2, continued

<b>MOV PM2, #I</b>	<b>RB port independent Input/Output control</b>																
Machine Code:	<table border="1" style="display: inline-table; margin-right: 20px;"> <tr> <td>0</td><td>1</td><td>0</td><td>1</td><td>0</td><td>1</td><td>1</td><td>1</td> </tr> </table> <table border="1" style="display: inline-table;"> <tr> <td>1</td><td>0</td><td>0</td><td>0</td><td>I3</td><td>I2</td><td>I1</td><td>I0</td> </tr> </table>	0	1	0	1	0	1	1	1	1	0	0	0	I3	I2	I1	I0
0	1	0	1	0	1	1	1										
1	0	0	0	I3	I2	I1	I0										
Machine Cycle:	1																
Operation:	Input/output control of 4 RB port pins is independent.																
Description:	<p>I0 = 0: RB.0 is output pin; I0 = 1: RB.0 is input pin.                      I1 = 0: RB.1 is output pin; I1 = 1: RB.1 is input pin.                      I2 = 0: RB.2 is output pin; I2 = 1: RB.2 is input pin.                      I3 = 0: RB.3 is output pin; I3 = 1: RB.3 is input pin.                      Default condition RB port is input mode (PM2 = 1111B).</p>																
<b>MOV R, ACC</b>	<b>Move ACC contents to R</b>																
Machine Code:	<table border="1" style="display: inline-table; margin-right: 20px;"> <tr> <td>0</td><td>1</td><td>0</td><td>1</td><td>1</td><td>0</td><td>0</td><td>1</td> </tr> </table> <table border="1" style="display: inline-table;"> <tr> <td>1</td><td>R6</td><td>R5</td><td>R4</td><td>R3</td><td>R2</td><td>R1</td><td>R0</td> </tr> </table>	0	1	0	1	1	0	0	1	1	R6	R5	R4	R3	R2	R1	R0
0	1	0	1	1	0	0	1										
1	R6	R5	R4	R3	R2	R1	R0										
Machine Cycle:	1																
Operation:	$R \leftarrow (ACC)$																
Description:	The contents of the ACC are loaded to the data memory location addressed by R6 to R0.																
<b>MOVA R, RA</b>	<b>Input RA port data to ACC &amp; R</b>																
Machine Code:	<table border="1" style="display: inline-table; margin-right: 20px;"> <tr> <td>0</td><td>1</td><td>0</td><td>1</td><td>1</td><td>0</td><td>1</td><td>1</td> </tr> </table> <table border="1" style="display: inline-table;"> <tr> <td>0</td><td>R6</td><td>R5</td><td>R4</td><td>R3</td><td>R2</td><td>R1</td><td>R0</td> </tr> </table>	0	1	0	1	1	0	1	1	0	R6	R5	R4	R3	R2	R1	R0
0	1	0	1	1	0	1	1										
0	R6	R5	R4	R3	R2	R1	R0										
Machine Cycle:	1																
Operation:	$ACC, R \leftarrow [RA]$																
Description:	The data on port RA are loaded into the data memory location addressed by R6 to R0 and the ACC.																
Flag Affected:	ZF																



Instruction Set Table 2, continued

<b>MOVA R, RB</b>	<b>Input RB port data to ACC &amp; R</b>		
Machine Code:	<table border="1"> <tr> <td>0 1 0 1 1 0 1 1</td> <td>1 R6 R5 R4 R3 R2 R1 R0</td> </tr> </table>	0 1 0 1 1 0 1 1	1 R6 R5 R4 R3 R2 R1 R0
0 1 0 1 1 0 1 1	1 R6 R5 R4 R3 R2 R1 R0		
Machine Cycle:	1		
Operation:	ACC , R ← [RB]		
Description:	The data on port RB are loaded into the data memory location addressed by R6 to R0 and the ACC.		
Flag Affected:	ZF		
<b>MOVA R, RC</b>	<b>Input RC port data to ACC &amp; R</b>		
Machine Code:	<table border="1"> <tr> <td>0 1 0 0 1 0 1 1</td> <td>0 R6 R5 R4 R3 R2 R1 R0</td> </tr> </table>	0 1 0 0 1 0 1 1	0 R6 R5 R4 R3 R2 R1 R0
0 1 0 0 1 0 1 1	0 R6 R5 R4 R3 R2 R1 R0		
Machine Cycle:	1		
Operation:	ACC , R ← [RC]		
Description:	The input data on the input port RC are loaded into the data memory location addressed by R6 to R0 and the ACC.		
Flag Affected:	ZF		
<b>MOVA R, RD</b>	<b>Input RD port data to ACC &amp; R</b>		
Machine Code:	<table border="1"> <tr> <td>0 1 0 0 1 0 1 1</td> <td>1 R6 R5 R4 R3 R2 R1 R0</td> </tr> </table>	0 1 0 0 1 0 1 1	1 R6 R5 R4 R3 R2 R1 R0
0 1 0 0 1 0 1 1	1 R6 R5 R4 R3 R2 R1 R0		
Machine Cycle:	1		
Operation:	ACC , R ← [RD]		
Description:	The input data on the input port RD are loaded into the data memory location addressed by R6 to R0 and the ACC.		
Flag Affected:	ZF		



Instruction Set Table 2, continued

<b>MOV R, WR</b>	<b>Move WR contents to R</b>		
Machine Code:	<table border="1"> <tr> <td>1 1 1 1 1 W3 W2 W1</td> <td>W0 R6 R5 R4 R3 R2 R1 R0</td> </tr> </table>	1 1 1 1 1 W3 W2 W1	W0 R6 R5 R4 R3 R2 R1 R0
1 1 1 1 1 W3 W2 W1	W0 R6 R5 R4 R3 R2 R1 R0		
Machine Cycle:	1		
Operation:	$R \leftarrow (WR)$		
Description:	The contents of the WR are loaded to the data memory location addressed by R6 to R0.		
<b>MOV R, #I</b>	<b>Load immediate data to R</b>		
Machine Code:	<table border="1"> <tr> <td>1 0 1 1 1 I3 I2 I1</td> <td>I0 R6 R5 R4 R3 R2 R1 R0</td> </tr> </table>	1 0 1 1 1 I3 I2 I1	I0 R6 R5 R4 R3 R2 R1 R0
1 0 1 1 1 I3 I2 I1	I0 R6 R5 R4 R3 R2 R1 R0		
Machine Cycle:	1		
Operation:	$R \leftarrow I$		
Description:	The immediate data I are loaded to the data memory location addressed by R6 to R0.		
<b>MOV RA, R</b>	<b>Output R contents to RA port</b>		
Machine Code:	<table border="1"> <tr> <td>0 1 0 1 1 0 1 0</td> <td>0 R6 R5 R4 R3 R2 R1 R0</td> </tr> </table>	0 1 0 1 1 0 1 0	0 R6 R5 R4 R3 R2 R1 R0
0 1 0 1 1 0 1 0	0 R6 R5 R4 R3 R2 R1 R0		
Machine Cycle:	1		
Operation:	$[RA] \leftarrow (R)$		
Description:	The data in the data memory location addressed by R6 to R0 are output to the port RA.		



Instruction Set Table 2, continued

<b>MOV RB, R</b>	<b>Output R contents to RB port</b>								
Machine Code:	<table border="1"> <tr> <td>0 1 0 1 1 0 1 0</td> <td>1 R6 R5 R4 R3 R2 R1 R0</td> </tr> </table>	0 1 0 1 1 0 1 0	1 R6 R5 R4 R3 R2 R1 R0						
0 1 0 1 1 0 1 0	1 R6 R5 R4 R3 R2 R1 R0								
Machine Cycle:	1								
Operation:	[RB] ← (R)								
Description:	The contents of the data memory location addressed by R6 to R0 are output to the port RB.								
<b>MOV RE, R</b>	<b>Output R contents to port RE</b>								
Machine Code:	<table border="1"> <tr> <td>0 1 0 1 1 1 1 0</td> <td>0 R6 R5 R4 R3 R2 R1 R0</td> </tr> </table>	0 1 0 1 1 1 1 0	0 R6 R5 R4 R3 R2 R1 R0						
0 1 0 1 1 1 1 0	0 R6 R5 R4 R3 R2 R1 R0								
Machine Cycle:	1								
Operation:	[RE] ← (R)								
Description:	The contents of the data memory location addressed by R6 to R0 are output to port RE.								
<b>MOV SCR, #I</b>	<b>System Clock Register control</b>								
Machine Code:	<table border="1"> <tr> <td>0 1 0 1 0 1 0 0</td> <td>0 0 0 0 I3 I2 I1 I0</td> </tr> </table>	0 1 0 1 0 1 0 0	0 0 0 0 I3 I2 I1 I0						
0 1 0 1 0 1 0 0	0 0 0 0 I3 I2 I1 I0								
Machine Cycle:	1								
Operation:	System clock control								
Description:	<p>If the operation mode is the dual clock operation selected by the option codes, the system clock and oscillator can be arranged by controlling the system clock register.</p> <p>SCR bits decription:</p> <table border="1"> <tr> <td>Bit 0</td> <td>= 0, Fosc = Fm = 1, Fosc = Fs</td> </tr> <tr> <td>Bit 1</td> <td>= 0, main oscillator is enabled = 1, main oscillator is disabled</td> </tr> <tr> <td>Bit 2</td> <td>Reserved</td> </tr> <tr> <td>Bit 3</td> <td>= 0, divider 1 is 14-stage = 1, divider 1 is 13-stage</td> </tr> </table>	Bit 0	= 0, Fosc = Fm = 1, Fosc = Fs	Bit 1	= 0, main oscillator is enabled = 1, main oscillator is disabled	Bit 2	Reserved	Bit 3	= 0, divider 1 is 14-stage = 1, divider 1 is 13-stage
Bit 0	= 0, Fosc = Fm = 1, Fosc = Fs								
Bit 1	= 0, main oscillator is enabled = 1, main oscillator is disabled								
Bit 2	Reserved								
Bit 3	= 0, divider 1 is 14-stage = 1, divider 1 is 13-stage								



Instruction Set Table 2, continued

<b>MOV SEF, #I</b>	<b>Set/Reset STOP mode wake-up Enable Flag for port RC</b>										
Machine Code:	<table border="1"> <tr> <td>0 1 0 1 0 0 1 0</td> <td>0 0 0 0 13 12 11 10</td> </tr> </table>	0 1 0 1 0 0 1 0	0 0 0 0 13 12 11 10								
0 1 0 1 0 0 1 0	0 0 0 0 13 12 11 10										
Machine Cycle:	1										
Operation:	Set/reset STOP mode wake-up enable flag for port RC										
Description:	<p>The data specified by I cause a wake-up from the STOP mode. The falling-edge signal on port RC can be specified independently.</p> <table border="1"> <tr> <td>I0 to I3</td> <td>Falling edge signal on port RC</td> </tr> <tr> <td>I0 = 1</td> <td>RC0</td> </tr> <tr> <td>I1 = 1</td> <td>RC1</td> </tr> <tr> <td>I2 = 1</td> <td>RC2</td> </tr> <tr> <td>I3 = 1</td> <td>RC3</td> </tr> </table>	I0 to I3	Falling edge signal on port RC	I0 = 1	RC0	I1 = 1	RC1	I2 = 1	RC2	I3 = 1	RC3
I0 to I3	Falling edge signal on port RC										
I0 = 1	RC0										
I1 = 1	RC1										
I2 = 1	RC2										
I3 = 1	RC3										
<b>MOV TM0, #I</b>	<b>Timer 0 set</b>										
Machine Code:	<table border="1"> <tr> <td>0 0 0 1 0 0 0 0</td> <td>17 16 15 14 13 12 11 10</td> </tr> </table>	0 0 0 1 0 0 0 0	17 16 15 14 13 12 11 10								
0 0 0 1 0 0 0 0	17 16 15 14 13 12 11 10										
Machine Cycle:	1										
Operation:	Timer 0 set										
Description:	The data specified by I7 to I0 is loaded to the Timer 0 to start the timer.										
<b>MOV TM0L, R</b>	<b>Move R contents to TM0L</b>										
Machine Code:	<table border="1"> <tr> <td>0 0 0 1 0 1 0 0</td> <td>0 R6 R5 R4 R3 R2 R1 R0</td> </tr> </table>	0 0 0 1 0 1 0 0	0 R6 R5 R4 R3 R2 R1 R0								
0 0 0 1 0 1 0 0	0 R6 R5 R4 R3 R2 R1 R0										
Machine Cycle:	1										
Operation:	TM0L ← (R)										
Description:	The contents of the data memory location addressed by R6 to R0 are loaded into the TM0L.										



Instruction Set Table 2, continued

<b>MOV TM0H, R</b>	<b>Move R contents to TM0H</b>																
Machine code:	<table border="1" style="display: inline-table; margin-right: 20px;"> <tr> <td>0</td><td>0</td><td>0</td><td>1</td><td>0</td><td>1</td><td>0</td><td>0</td> </tr> </table> <table border="1" style="display: inline-table;"> <tr> <td>1</td><td>R6</td><td>R5</td><td>R4</td><td>R3</td><td>R2</td><td>R1</td><td>R0</td> </tr> </table>	0	0	0	1	0	1	0	0	1	R6	R5	R4	R3	R2	R1	R0
0	0	0	1	0	1	0	0										
1	R6	R5	R4	R3	R2	R1	R0										
Machine Cycle:	1																
Operation:	TM0H ← (R)																
Description:	The contents of the data memory location addressed by R6 to R0 are loaded into the TM0H.																
<b>MOV TM1, #I</b>	<b>Timer 1 set</b>																
Machine Code:	<table border="1" style="display: inline-table; margin-right: 20px;"> <tr> <td>0</td><td>0</td><td>0</td><td>1</td><td>0</td><td>0</td><td>0</td><td>1</td> </tr> </table> <table border="1" style="display: inline-table;"> <tr> <td>I7</td><td>I6</td><td>I5</td><td>I4</td><td>I3</td><td>I2</td><td>I1</td><td>I0</td> </tr> </table>	0	0	0	1	0	0	0	1	I7	I6	I5	I4	I3	I2	I1	I0
0	0	0	1	0	0	0	1										
I7	I6	I5	I4	I3	I2	I1	I0										
Machine Cycle:	1																
Operation:	Timer 1 set																
Description:	The data specified by I7 to I0 is loaded to the Timer 1 to start the timer.																
<b>MOV TM1L, R</b>	<b>Move R contents to TM1L</b>																
Machine Code:	<table border="1" style="display: inline-table; margin-right: 20px;"> <tr> <td>0</td><td>0</td><td>0</td><td>1</td><td>0</td><td>1</td><td>0</td><td>1</td> </tr> </table> <table border="1" style="display: inline-table;"> <tr> <td>0</td><td>R6</td><td>R5</td><td>R4</td><td>R3</td><td>R2</td><td>R1</td><td>R0</td> </tr> </table>	0	0	0	1	0	1	0	1	0	R6	R5	R4	R3	R2	R1	R0
0	0	0	1	0	1	0	1										
0	R6	R5	R4	R3	R2	R1	R0										
Machine Cycle:	1																
Operation:	TM1L ← (R)																
Description:	The contents of the data memory location addressed by R6 to R0 are loaded into the TM1L.																



Instruction Set Table 2, continued

<b>MOV TM1H, R</b>	<b>Move R contents to TM1H</b>																
Machine code:	<table border="1" style="display: inline-table; margin-right: 20px;"> <tr> <td>0</td><td>0</td><td>0</td><td>1</td><td>0</td><td>1</td><td>0</td><td>1</td> </tr> </table> <table border="1" style="display: inline-table;"> <tr> <td>1</td><td>R6</td><td>R5</td><td>R4</td><td>R3</td><td>R2</td><td>R1</td><td>R0</td> </tr> </table>	0	0	0	1	0	1	0	1	1	R6	R5	R4	R3	R2	R1	R0
0	0	0	1	0	1	0	1										
1	R6	R5	R4	R3	R2	R1	R0										
Machine Cycle:	1																
Operation:	TM1H ← (R)																
Description:	The contents of the data memory location addressed by R6 to R0 are loaded into the TM1H.																
<b>MOV TABL, R</b>	<b>Move R contents to TABL</b>																
Machine Code:	<table border="1" style="display: inline-table; margin-right: 20px;"> <tr> <td>1</td><td>0</td><td>0</td><td>1</td><td>1</td><td>0</td><td>0</td><td>0</td> </tr> </table> <table border="1" style="display: inline-table;"> <tr> <td>0</td><td>R6</td><td>R5</td><td>R4</td><td>R3</td><td>R2</td><td>R1</td><td>R0</td> </tr> </table>	1	0	0	1	1	0	0	0	0	R6	R5	R4	R3	R2	R1	R0
1	0	0	1	1	0	0	0										
0	R6	R5	R4	R3	R2	R1	R0										
Machine Cycle:	1																
Operation:	TABL ← (R)																
Description:	The contents of the data memory location addressed by R6 to R0 are loaded into the TABL.																
<b>MOV TABH, R</b>	<b>Move R contents to TABH</b>																
Machine code:	<table border="1" style="display: inline-table; margin-right: 20px;"> <tr> <td>1</td><td>0</td><td>0</td><td>1</td><td>1</td><td>0</td><td>0</td><td>0</td> </tr> </table> <table border="1" style="display: inline-table;"> <tr> <td>1</td><td>R6</td><td>R5</td><td>R4</td><td>R3</td><td>R2</td><td>R1</td><td>R0</td> </tr> </table>	1	0	0	1	1	0	0	0	1	R6	R5	R4	R3	R2	R1	R0
1	0	0	1	1	0	0	0										
1	R6	R5	R4	R3	R2	R1	R0										
Machine Cycle:	1																
Operation:	TABH ← (R)																
Description:	The contents of the data memory location addressed by R6 to R0 are loaded into the TABH.																



Instruction Set Table 2, continued

<b>MOV WR, LCDR</b>	<b>Load LCDR contents to WR</b>																
Machine Code:	<table border="1" style="display: inline-table; margin-right: 20px;"> <tr> <td>0</td><td>1</td><td>0</td><td>0</td><td>0</td><td>1</td><td>1</td><td>D4</td> </tr> </table> <table border="1" style="display: inline-table;"> <tr> <td>D3</td><td>D2</td><td>D1</td><td>D0</td><td>W3</td><td>W2</td><td>W1</td><td>W0</td> </tr> </table>	0	1	0	0	0	1	1	D4	D3	D2	D1	D0	W3	W2	W1	W0
0	1	0	0	0	1	1	D4										
D3	D2	D1	D0	W3	W2	W1	W0										
Machine Cycle:	1																
Operation:	WR ← (LCDR)																
Description:	The contents of the LCD data RAM location addressed by D4 to D0 are loaded to the WR.																
<b>MOV WR, R</b>	<b>Move R contents to WR</b>																
Machine Code:	<table border="1" style="display: inline-table; margin-right: 20px;"> <tr> <td>1</td><td>1</td><td>1</td><td>0</td><td>1</td><td>W3</td><td>W2</td><td>W1</td> </tr> </table> <table border="1" style="display: inline-table;"> <tr> <td>W0</td><td>R6</td><td>R5</td><td>R4</td><td>R3</td><td>R2</td><td>R1</td><td>R0</td> </tr> </table>	1	1	1	0	1	W3	W2	W1	W0	R6	R5	R4	R3	R2	R1	R0
1	1	1	0	1	W3	W2	W1										
W0	R6	R5	R4	R3	R2	R1	R0										
Machine Cycle:	1																
Operation:	WR ← (R)																
Description:	The contents of the data memory location addressed by R6 to R0 are loaded to the WR.																
<b>MOV WR, @R</b>	<b>Indirect load from R to WR</b>																
Machine Code:	<table border="1" style="display: inline-table; margin-right: 20px;"> <tr> <td>1</td><td>1</td><td>0</td><td>0</td><td>1</td><td>W3</td><td>W2</td><td>W1</td> </tr> </table> <table border="1" style="display: inline-table;"> <tr> <td>W0</td><td>R6</td><td>R5</td><td>R4</td><td>R3</td><td>R2</td><td>R1</td><td>R0</td> </tr> </table>	1	1	0	0	1	W3	W2	W1	W0	R6	R5	R4	R3	R2	R1	R0
1	1	0	0	1	W3	W2	W1										
W0	R6	R5	R4	R3	R2	R1	R0										
Machine Cycle:	2																
Operation:	WR ← [PR (bit2, bit1, bit0) × 10H + (R)]																
Description:	The data memory contents of address [PR (bit2, bit1, bit0) × 10H + (R)] are loaded to the WR.																



Instruction Set Table 2, continued

<b>MOV @R, WR</b>	<b>Indirect load from WR to R</b>																
Machine Code:	<table border="1" style="display: inline-table; margin-right: 20px;"> <tr> <td>1</td><td>1</td><td>0</td><td>1</td><td>1</td><td>W3</td><td>W2</td><td>W1</td> </tr> </table> <table border="1" style="display: inline-table;"> <tr> <td>W0</td><td>R6</td><td>R5</td><td>R4</td><td>R3</td><td>R2</td><td>R1</td><td>R0</td> </tr> </table>	1	1	0	1	1	W3	W2	W1	W0	R6	R5	R4	R3	R2	R1	R0
1	1	0	1	1	W3	W2	W1										
W0	R6	R5	R4	R3	R2	R1	R0										
Machine Cycle:	2																
Operation:	$[PR(\text{bit2}, \text{bit1}, \text{bit0}) \times 10H + (R)] \leftarrow WR$																
Description:	The contents of the WR are loaded to the data memory location addressed by $[PR(\text{bit2}, \text{bit1}, \text{bit0}) \times 10H + (R)]$ .																
<b>MOV PAGE, R</b>	<b>Move R contents to Page Register</b>																
Machine Code:	<table border="1" style="display: inline-table; margin-right: 20px;"> <tr> <td>0</td><td>1</td><td>0</td><td>1</td><td>1</td><td>1</td><td>1</td><td>0</td> </tr> </table> <table border="1" style="display: inline-table;"> <tr> <td>1</td><td>R6</td><td>R5</td><td>R4</td><td>R3</td><td>R2</td><td>R1</td><td>R0</td> </tr> </table>	0	1	0	1	1	1	1	0	1	R6	R5	R4	R3	R2	R1	R0
0	1	0	1	1	1	1	0										
1	R6	R5	R4	R3	R2	R1	R0										
Machine Cycle:	1																
Operation:	$PR \leftarrow (R)$																
Description:	The contents of the data memory location addressed by R6 to R0 are loaded to the Page Register.																
<b>MOVA R, CF</b>	<b>Move CF contents to ACC.0 &amp; R.0</b>																
Machine Code:	<table border="1" style="display: inline-table; margin-right: 20px;"> <tr> <td>0</td><td>1</td><td>0</td><td>1</td><td>1</td><td>0</td><td>0</td><td>1</td> </tr> </table> <table border="1" style="display: inline-table;"> <tr> <td>0</td><td>R6</td><td>R5</td><td>R4</td><td>R3</td><td>R2</td><td>R1</td><td>R0</td> </tr> </table>	0	1	0	1	1	0	0	1	0	R6	R5	R4	R3	R2	R1	R0
0	1	0	1	1	0	0	1										
0	R6	R5	R4	R3	R2	R1	R0										
Machine Cycle:	1																
Operation:	$ACC.0, R.0 \leftarrow (CF)$																
Description:	The contents of CF is loaded to bit 0 of the data memory location addressed by R6 to R0 and the ACC. The other bits of the data memory and ACC are reset to "0."																
Flag Affected:	ZF																



Instruction Set Table 2, continued

<b>MOVA R, HCFH</b>	<b>Move HCF4- 7 to ACC &amp; R</b>								
Machine Code:	<table border="1"> <tr> <td>0 1 0 0 1 0 0 1</td> <td>1 R6 R5 R4 R3 R2 R1 R0</td> </tr> </table>	0 1 0 0 1 0 0 1	1 R6 R5 R4 R3 R2 R1 R0						
0 1 0 0 1 0 0 1	1 R6 R5 R4 R3 R2 R1 R0								
Machine Cycle:	1								
Operation:	ACC, R ← HCF4-7								
Description:	<p>The contents of HCF bit 4 to bit 7 (HCF4 to HCF7) are loaded to the data memory location addressed by R6 to R0 and the ACC. The ACC contents and the meaning of the bits after execution of this instruction are as follows:</p> <table border="1"> <tr> <td>Bit 0</td> <td>HCF4: "1" when the HOLD mode is released by overflow from Divider 1.</td> </tr> <tr> <td>Bit 1</td> <td>HCF5: "1" when the HOLD mode is released by underflow from Timer 1.</td> </tr> <tr> <td>Bit 2</td> <td>Reserved.</td> </tr> <tr> <td>Bit 3</td> <td>Reserved.</td> </tr> </table>	Bit 0	HCF4: "1" when the HOLD mode is released by overflow from Divider 1.	Bit 1	HCF5: "1" when the HOLD mode is released by underflow from Timer 1.	Bit 2	Reserved.	Bit 3	Reserved.
Bit 0	HCF4: "1" when the HOLD mode is released by overflow from Divider 1.								
Bit 1	HCF5: "1" when the HOLD mode is released by underflow from Timer 1.								
Bit 2	Reserved.								
Bit 3	Reserved.								
Flag Affected:	ZF								
<b>MOVA R, HCFL</b>	<b>Move HCF0- 3 to ACC &amp; R</b>								
Machine Code:	<table border="1"> <tr> <td>0 1 0 0 1 0 0 1</td> <td>0 R6 R5 R4 R3 R2 R1 R0</td> </tr> </table>	0 1 0 0 1 0 0 1	0 R6 R5 R4 R3 R2 R1 R0						
0 1 0 0 1 0 0 1	0 R6 R5 R4 R3 R2 R1 R0								
Machine Cycle:	1								
Operation:	ACC, R ← HCF0-3								
Description:	<p>The contents of HCF bit 0 to bit 3 (HCF0 to HCF3) are loaded to the data memory location addressed by R6 to R0 and the ACC. The ACC contents and the meaning of the bits after execution of this instruction are as follows:</p> <table border="1"> <tr> <td>Bit 0</td> <td>HCF0: "1" when the HOLD mode is released by overflow from the Divider 0.</td> </tr> <tr> <td>Bit 1</td> <td>HCF1: "1" when the HOLD mode is released by underflow from Timer 0.</td> </tr> <tr> <td>Bit 2</td> <td>HCF2: "1" when the HOLD mode is released by a signal change on port RC.</td> </tr> <tr> <td>Bit 3</td> <td>Reserved</td> </tr> </table>	Bit 0	HCF0: "1" when the HOLD mode is released by overflow from the Divider 0.	Bit 1	HCF1: "1" when the HOLD mode is released by underflow from Timer 0.	Bit 2	HCF2: "1" when the HOLD mode is released by a signal change on port RC.	Bit 3	Reserved
Bit 0	HCF0: "1" when the HOLD mode is released by overflow from the Divider 0.								
Bit 1	HCF1: "1" when the HOLD mode is released by underflow from Timer 0.								
Bit 2	HCF2: "1" when the HOLD mode is released by a signal change on port RC.								
Bit 3	Reserved								
Flag Affected:	ZF								



Instruction Set Table 2, continued

<b>MOVA R, PAGE</b>	<b>Move Page Register contents to ACC &amp; R</b>
Machine Code:	<div style="display: flex; align-items: center; gap: 20px;"> <div style="border: 1px solid black; padding: 2px 10px;">0 1 0 1 1 1 1 1</div> <div style="border: 1px solid black; padding: 2px 10px;">1 R6 R5 R4 R3 R2 R1 R0</div> </div>
Machine Cycle:	1
Operation:	ACC , R ← (Page Register)
Description:	The contents of the Page Register (PR) are loaded to the data memory location addressed by R6 to R0 and the ACC.
Flag Affected:	ZF
<b>MOVA R, PSR0</b>	<b>Move Port Status Register 0 contents to ACC &amp; R</b>
Machine Code:	<div style="display: flex; align-items: center; gap: 20px;"> <div style="border: 1px solid black; padding: 2px 10px;">0 1 0 0 1 1 1 1</div> <div style="border: 1px solid black; padding: 2px 10px;">0 R6 R5 R4 R3 R2 R1 R0</div> </div>
Machine Cycle:	1
Operation:	ACC, R ← RC port signal change flag (PSR0)
Description:	The contents of the RC port signal change flag (PSR0) are loaded to the data memory location addressed by R6 to R0 and the ACC. When the signal changes on any pin of the RC port, the corresponding signal change flag should be set to 1. Otherwise, it should be 0.
Flag Affected:	ZF
<b>MOVA R, WR</b>	<b>Move WR contents to ACC &amp; R</b>
Machine Code:	<div style="display: flex; align-items: center; gap: 20px;"> <div style="border: 1px solid black; padding: 2px 10px;">0 1 1 1 1 W3 W2 W1</div> <div style="border: 1px solid black; padding: 2px 10px;">W0 R6 R5 R4 R3 R2 R1 R0</div> </div>
Machine Cycle:	1
Operation:	ACC, R ← (WR)
Description:	The contents of the WR are loaded to the ACC and the data memory location addressed by R6 to R0.
Flag Affected:	ZF



Instruction Set Table 2, continued

<b>MOVA WR, R</b>	<b>Move R contents to ACC &amp; WR</b>																
Machine Code:	<table border="1" style="display: inline-table; margin-right: 20px;"> <tr> <td>0</td><td>1</td><td>1</td><td>0</td><td>1</td><td>W3</td><td>W2</td><td>W1</td> </tr> </table> <table border="1" style="display: inline-table;"> <tr> <td>W0</td><td>R6</td><td>R5</td><td>R4</td><td>R3</td><td>R2</td><td>R1</td><td>R0</td> </tr> </table>	0	1	1	0	1	W3	W2	W1	W0	R6	R5	R4	R3	R2	R1	R0
0	1	1	0	1	W3	W2	W1										
W0	R6	R5	R4	R3	R2	R1	R0										
Machine Cycle:	1																
Operation:	ACC, WR ← (R)																
Description:	The contents of the data memory location addressed by R6 to R0 are loaded to the WR and the ACC.																
Flag Affected:	ZF																
<b>MOVC R</b>	<b>Move look-up table ROM addressed by TABL and TABH to R</b>																
Machine code:	<table border="1" style="display: inline-table; margin-right: 20px;"> <tr> <td>1</td><td>0</td><td>0</td><td>1</td><td>1</td><td>0</td><td>0</td><td>1</td> </tr> </table> <table border="1" style="display: inline-table;"> <tr> <td>0</td><td>R6</td><td>R5</td><td>R4</td><td>R3</td><td>R2</td><td>R1</td><td>R0</td> </tr> </table>	1	0	0	1	1	0	0	1	0	R6	R5	R4	R3	R2	R1	R0
1	0	0	1	1	0	0	1										
0	R6	R5	R4	R3	R2	R1	R0										
Machine Cycle:	2																
Operation:	$WR \leftarrow [((TABH) \times 100H + (TABL)) \times 10H + ACC]$																
Description:	The contents of the look-up table ROM location addressed by TABH, TABL and ACC are loaded to R.																
<b>MOVC WR, #I</b>	<b>Move look-up table ROM addressed by #I and ACC to WR</b>																
Machine code:	<table border="1" style="display: inline-table; margin-right: 20px;"> <tr> <td>1</td><td>0</td><td>1</td><td>0</td><td>1</td><td>W3</td><td>W2</td><td>W1</td> </tr> </table> <table border="1" style="display: inline-table;"> <tr> <td>W0</td><td>I6</td><td>I5</td><td>I4</td><td>I3</td><td>I2</td><td>I1</td><td>I0</td> </tr> </table>	1	0	1	0	1	W3	W2	W1	W0	I6	I5	I4	I3	I2	I1	I0
1	0	1	0	1	W3	W2	W1										
W0	I6	I5	I4	I3	I2	I1	I0										
Machine Cycle:	2																
Operation:	$WR \leftarrow [(I6 \sim I0) \times 10H + (ACC)]$																
Description:	The contents of the look-up table ROM location addressed by I6 to I0 and the ACC are loaded to R.																
<b>NOP</b>	<b>No Operation</b>																
Machine Code:	<table border="1" style="display: inline-table; margin-right: 20px;"> <tr> <td>0</td><td>0</td><td>0</td><td>0</td><td>0</td><td>0</td><td>0</td><td>0</td> </tr> </table> <table border="1" style="display: inline-table;"> <tr> <td>0</td><td>0</td><td>0</td><td>0</td><td>0</td><td>0</td><td>0</td><td>0</td> </tr> </table>	0	0	0	0	0	0	0	0	0	0	0	0	0	0	0	0
0	0	0	0	0	0	0	0										
0	0	0	0	0	0	0	0										
Machine Cycle:	1																
Operation:	No Operation																



Instruction Set Table 2, continued

<b>ORL R, ACC</b>	<b>OR R to ACC</b>
<p>Machine Code:</p> <p>Machine Cycle:</p> <p>Operation:</p> <p>Description:</p> <p>Flag Affected:</p>	<div style="display: flex; justify-content: space-around; align-items: center;"> <div style="border: 1px solid black; padding: 2px 10px;">0 0 1 1 1 0 1 0</div> <div style="border: 1px solid black; padding: 2px 10px;">0 R6 R5 R4 R3 R2 R1 R0</div> </div> <p>1</p> <p><math>ACC \leftarrow (R) \wedge (ACC)</math></p> <p>The contents of the data memory location addressed by R6 to R0 and the ACC are ORed and the result is loaded into the ACC.</p> <p>ZF</p>
<b>ORL WR, #I</b>	<b>OR immediate data to WR</b>
<p>Machine Code:</p> <p>Machine Cycle:</p> <p>Operation:</p> <p>Description:</p> <p>Flag Affected:</p>	<div style="display: flex; justify-content: space-around; align-items: center;"> <div style="border: 1px solid black; padding: 2px 10px;">0 0 1 1 1 1 1 0</div> <div style="border: 1px solid black; padding: 2px 10px;">I3 I2 I1 I0 W3 W2 W1 W0</div> </div> <p>1</p> <p><math>ACC \leftarrow (WR) \wedge I</math></p> <p>The contents of the Working Register (WR) and the immediate data I are ORed and the result is loaded into the ACC.</p> <p>ZF</p>
<b>ORLR R, ACC</b>	<b>OR R to ACC</b>
<p>Machine Code:</p> <p>Machine Cycle:</p> <p>Operation:</p> <p>Description:</p> <p>Flag Affected:</p>	<div style="display: flex; justify-content: space-around; align-items: center;"> <div style="border: 1px solid black; padding: 2px 10px;">0 0 1 1 1 0 1 1</div> <div style="border: 1px solid black; padding: 2px 10px;">0 R6 R5 R4 R3 R2 R1 R0</div> </div> <p>1</p> <p><math>ACC, R \leftarrow (R) \wedge (ACC)</math></p> <p>The contents of the data memory location addressed by R6 to R0 and the ACC are ORed and the result is placed in the data memory and the ACC.</p> <p>ZF</p>



Instruction Set Table 2, continued

<b>ORLR</b> <b>WR , #I</b>	<b>OR immediate data to WR</b>
<p>Machine Code:</p> <p>Machine Cycle:</p> <p>Operation:</p> <p>Description:</p> <p>Flag Affected:</p>	<div style="display: flex; justify-content: space-around; align-items: center;"> <div style="border: 1px solid black; padding: 2px 10px;">0 0 1 1 1 1 1 1</div> <div style="border: 1px solid black; padding: 2px 10px;">I3 I2 I1 I0 W3 W2 W1 W0</div> </div> <p>1</p> <p>ACC, WR ← (WR) ^ I</p> <p>The contents of the Working Register(WR) and the immediate data I are ORed and the result is placed in the WR and the ACC.</p> <p>ZF</p>
<b>RLC</b> <b>R</b>	<b>Rotate Left R with CF</b>
<p>Machine Code:</p> <p>Machine Cycle:</p> <p>Operation:</p> <p>Description:</p> <p>Flag Affected:</p>	<div style="display: flex; justify-content: space-around; align-items: center;"> <div style="border: 1px solid black; padding: 2px 10px;">0 1 0 0 1 1 0 0</div> <div style="border: 1px solid black; padding: 2px 10px;">1 R6 R5 R4 R3 R2 R1 R0</div> </div> <p>1</p> <p>ACC.n, R.n ← R.n-1; ACC.0, R.0 ← CF; CF ← R.3</p> <p>The contents of the ACC and the data memory location addressed by R6 to R0 are rotated left one bit, bit 3 is rotated into CF, and CF rotated into bit 0 (LSB). The same contents are loaded into the ACC.</p> <p>CF &amp; ZF</p>
<b>RRC</b> <b>R</b>	<b>Rotate Right R with CF</b>
<p>Machine Code:</p> <p>Machine Cycle:</p> <p>Operation:</p> <p>Description:</p> <p>Flag Affected:</p>	<div style="display: flex; justify-content: space-around; align-items: center;"> <div style="border: 1px solid black; padding: 2px 10px;">0 1 0 0 1 1 0 1</div> <div style="border: 1px solid black; padding: 2px 10px;">1 R6 R5 R4 R3 R2 R1 R0</div> </div> <p>1</p> <p>ACC.n, R.n ← R.n+1; ACC.3, R.3 ← CF; CF ← R.0</p> <p>The contents of the ACC and the data memory location addressed by R6 to R0 are rotated right one bit, bit 0 is rotated into CF, and CF is rotated into bit 3 (MSB). The same contents are loaded into the ACC.</p> <p>CF &amp; ZF</p>



Instruction Set Table 2, continued

<b>RTN</b>	<b>Return from subroutine</b>		
Machine Code:	<table border="1"> <tr> <td>0 0 0 0 0 0 0 1</td> <td>0 0 0 0 0 0 0 0</td> </tr> </table>	0 0 0 0 0 0 0 1	0 0 0 0 0 0 0 0
0 0 0 0 0 0 0 1	0 0 0 0 0 0 0 0		
Machine Cycle:	1		
Operation:	(PC) ← STACK		
Description:	The program counter (PC10 to PC0) is restored from the stack. A return from a subroutine occurs.		
<b>SBC R, ACC</b>	<b>Subtract ACC from R with Borrow</b>		
Machine Code:	<table border="1"> <tr> <td>0 0 0 0 1 0 1 0</td> <td>0 R6 R5 R4 R3 R2 R1 R0</td> </tr> </table>	0 0 0 0 1 0 1 0	0 R6 R5 R4 R3 R2 R1 R0
0 0 0 0 1 0 1 0	0 R6 R5 R4 R3 R2 R1 R0		
Machine Cycle:	1		
Operation:	ACC ← (R) - (ACC) - (CF)		
Description:	The contents of the ACC and CF are binary subtracted from the contents of the data memory location addressed by R6 to R0 and the result is loaded into the ACC.		
Flag Affected:	CF & ZF		
<b>SBC WR, #I</b>	<b>Subtract immediate data from WR with Borrow</b>		
Machine Code:	<table border="1"> <tr> <td>0 0 0 0 1 1 1 0</td> <td>I3 I2 I1 I0 W3 W2 W1 W0</td> </tr> </table>	0 0 0 0 1 1 1 0	I3 I2 I1 I0 W3 W2 W1 W0
0 0 0 0 1 1 1 0	I3 I2 I1 I0 W3 W2 W1 W0		
Machine Cycle:	1		
Operation:	ACC ← (WR) - I - (CF)		
Description:	The immediate data I and CF are binary subtracted from the contents of the WR and the result is loaded into the ACC.		
Flag Affected:	CF & ZF		



Instruction Set Table 2, continued

<b>SBCR R, ACC</b>	<b>Subtract ACC from R with Borrow</b>
Machine Code:	<div style="display: flex; align-items: center; gap: 20px;"> <div style="border: 1px solid black; padding: 2px 10px;">0 0 0 0 1 0 1 1</div> <div style="border: 1px solid black; padding: 2px 10px;">0 R6 R5 R4 R3 R2 R1 R0</div> </div>
Machine Cycle:	1
Operation:	$ACC, R \leftarrow (R) - (ACC) - (CF)$
Description:	The contents of the ACC and CF are binary subtracted from the contents of the data memory location addressed by R6 to R0 and the result is placed in the ACC and the data memory.
Flag Affected:	CF & ZF
<b>SBCR WR, #I</b>	<b>Subtract immediate data from WR with Borrow</b>
Machine Code:	<div style="display: flex; align-items: center; gap: 20px;"> <div style="border: 1px solid black; padding: 2px 10px;">0 0 0 0 1 1 1 1</div> <div style="border: 1px solid black; padding: 2px 10px;">I3 I2 I1 I0 W3 W2 W1 W0</div> </div>
Machine Cycle:	1
Operation:	$ACC, R \leftarrow (WR) - I - (CF)$
Description:	The immediate data I and CF are binary subtracted from the contents of the WR and the result is placed in the ACC and the WR.
Flag Affected:	CF & ZF
<b>SET CF</b>	<b>Set CF</b>
Machine Code:	<div style="display: flex; align-items: center; gap: 20px;"> <div style="border: 1px solid black; padding: 2px 10px;">0 1 0 1 0 0 0 0</div> <div style="border: 1px solid black; padding: 2px 10px;">0 1 0 0 0 0 0 0</div> </div>
Machine Cycle:	1
Operation:	Set CF
Description:	Set Carry Flag to 1.
Flag Affected:	CF



Instruction Set Table 2, continued

<b>SET</b>	<b>PMF, #I</b>	<b>Set ParaMeter Flag</b>																
Machine Code:		<table border="1" style="display: inline-table; margin-right: 20px;"> <tr> <td>0</td><td>0</td><td>0</td><td>1</td><td>0</td><td>1</td><td>1</td><td>0</td> </tr> </table> <table border="1" style="display: inline-table;"> <tr> <td>0</td><td>0</td><td>0</td><td>0</td><td>I3</td><td>I2</td><td>I1</td><td>I0</td> </tr> </table>	0	0	0	1	0	1	1	0	0	0	0	0	I3	I2	I1	I0
0	0	0	1	0	1	1	0											
0	0	0	0	I3	I2	I1	I0											
Machine Cycle:		1																
Operation:		Set Parameter Flag																
Description:		Description of each flag: I0, I1, I2 : Reserved  I3 = 1 : The input clock of the watchdog timer is Fosc/16384.																
<b>SHLC</b>	<b>R</b>	<b>SHift Left R with CF and LSB = 0</b>																
Machine Code:		<table border="1" style="display: inline-table; margin-right: 20px;"> <tr> <td>0</td><td>1</td><td>0</td><td>0</td><td>1</td><td>1</td><td>0</td><td>0</td> </tr> </table> <table border="1" style="display: inline-table;"> <tr> <td>0</td><td>R6</td><td>R5</td><td>R4</td><td>R3</td><td>R2</td><td>R1</td><td>R0</td> </tr> </table>	0	1	0	0	1	1	0	0	0	R6	R5	R4	R3	R2	R1	R0
0	1	0	0	1	1	0	0											
0	R6	R5	R4	R3	R2	R1	R0											
Machine Cycle:		1																
Operation:		ACC.n, R.n ← R.n-1; ACC.0, R.0 ← 0; CF ← R.3																
Description:		The contents of the ACC and the data memory location addressed by R6 to R0 are shifted left one bit, but bit 3 is shifted into CF, and bit 0 (LSB) is replaced with "0." The same contents are loaded into the ACC.																
Flag Affected:		CF & ZF																
<b>SHRC</b>	<b>R</b>	<b>SHift Right R with CF and MSB = 0</b>																
Machine Code:		<table border="1" style="display: inline-table; margin-right: 20px;"> <tr> <td>0</td><td>1</td><td>0</td><td>0</td><td>1</td><td>1</td><td>0</td><td>1</td> </tr> </table> <table border="1" style="display: inline-table;"> <tr> <td>0</td><td>R6</td><td>R5</td><td>R4</td><td>R3</td><td>R2</td><td>R1</td><td>R0</td> </tr> </table>	0	1	0	0	1	1	0	1	0	R6	R5	R4	R3	R2	R1	R0
0	1	0	0	1	1	0	1											
0	R6	R5	R4	R3	R2	R1	R0											
Machine Cycle:		1																
Operation:		ACC.n, R.n ← R.n+1; ACC.3, R.3 ← 0; CF ← R.0																
Description:		The contents of the ACC and the data memory location addressed by R6 to R0 are shifted right one bit, but bit 0 is shifted into CF, and bit 3 (MSB) is replaced with "0." The same contents are loaded into the ACC.																
Flag Affected:		CF & ZF																



Instruction Set Table 2, continued

<b>SKB0</b>	<b>R</b>	<b>If bit 0 of R is equal to 1 then skip</b>																
Machine Code:		<table border="1" style="display: inline-table; margin-right: 20px;"> <tr> <td>1</td><td>0</td><td>0</td><td>0</td><td>1</td><td>0</td><td>0</td><td>0</td> </tr> </table> <table border="1" style="display: inline-table;"> <tr> <td>0</td><td>R6</td><td>R5</td><td>R4</td><td>R3</td><td>R2</td><td>R1</td><td>R0</td> </tr> </table>	1	0	0	0	1	0	0	0	0	R6	R5	R4	R3	R2	R1	R0
1	0	0	0	1	0	0	0											
0	R6	R5	R4	R3	R2	R1	R0											
Machine Cycle:		1																
Operation:		$PC \leftarrow (PC) + 2$ ; if R.0 = "1"																
Description:		If bit 0 of R is equal to 1, the program counter is incremented by 2 and a skip is produced. If bit 0 of R is not equal to 1, the program counter (PC) is incremented.																
<b>SKB1</b>	<b>R</b>	<b>If bit 1 of R is equal to 1 then skip</b>																
Machine Code:		<table border="1" style="display: inline-table; margin-right: 20px;"> <tr> <td>1</td><td>0</td><td>0</td><td>0</td><td>1</td><td>0</td><td>0</td><td>0</td> </tr> </table> <table border="1" style="display: inline-table;"> <tr> <td>1</td><td>R6</td><td>R5</td><td>R4</td><td>R3</td><td>R2</td><td>R1</td><td>R0</td> </tr> </table>	1	0	0	0	1	0	0	0	1	R6	R5	R4	R3	R2	R1	R0
1	0	0	0	1	0	0	0											
1	R6	R5	R4	R3	R2	R1	R0											
Machine Cycle:		1																
Operation:		$PC \leftarrow (PC) + 2$ ; if R.1 = "1"																
Description:		If bit 1 of R is equal to 1, the program counter is incremented by 2 and a skip is produced. If bit 1 of R is not equal to 1, the program counter (PC) is incremented.																
<b>SKB2</b>	<b>R</b>	<b>If bit 2 of R is equal to 1 then skip</b>																
Machine Code:		<table border="1" style="display: inline-table; margin-right: 20px;"> <tr> <td>1</td><td>0</td><td>0</td><td>0</td><td>1</td><td>0</td><td>1</td><td>0</td> </tr> </table> <table border="1" style="display: inline-table;"> <tr> <td>0</td><td>R6</td><td>R5</td><td>R4</td><td>R3</td><td>R2</td><td>R1</td><td>R0</td> </tr> </table>	1	0	0	0	1	0	1	0	0	R6	R5	R4	R3	R2	R1	R0
1	0	0	0	1	0	1	0											
0	R6	R5	R4	R3	R2	R1	R0											
Machine Cycle:		1																
Operation:		$PC \leftarrow (PC) + 2$ ; if R.2 = "1"																
Description:		If bit 2 of R is equal to 1, the program counter is incremented by 2 and a skip is produced. If bit 2 of R is not equal to 1, the program counter (PC) is incremented.																



Instruction Set Table 2, continued

<b>SKB3 R</b>	<b>If bit 3 of R is equal to 1 then skip</b>
Machine Code:	<div style="display: flex; justify-content: space-around; align-items: center;"> <div style="border: 1px solid black; padding: 2px 10px;">1 0 0 0 1 0 1 0</div> <div style="border: 1px solid black; padding: 2px 10px;">1 R6 R5 R4 R3 R2 R1 R0</div> </div>
Machine Cycle:	1
Operation:	$PC \leftarrow (PC) + 2$ ; if R.3 = "1"
Description:	If bit 3 of R is equal to 1, the program counter is incremented by 2 and a skip is produced. If bit 3 of R is not equal to 1, the program counter (PC) is incremented.
<b>STOP</b>	<b>Enter the STOP mode</b>
Machine Code:	<div style="display: flex; justify-content: space-around; align-items: center;"> <div style="border: 1px solid black; padding: 2px 10px;">0 0 0 0 0 0 0 0</div> <div style="border: 1px solid black; padding: 2px 10px;">1 1 0 0 0 0 0 0</div> </div>
Machine Cycle:	1
Operation:	STOP oscillator
Description:	Device enters STOP mode. When the falling edge signal of RC port is accepted, the $\mu C$ will wake up and execute the next instruction.
<b>SUB R, ACC</b>	<b>Subtract ACC from R</b>
Machine Code:	<div style="display: flex; justify-content: space-around; align-items: center;"> <div style="border: 1px solid black; padding: 2px 10px;">0 0 0 1 1 0 1 0</div> <div style="border: 1px solid black; padding: 2px 10px;">0 R6 R5 R4 R3 R2 R1 R0</div> </div>
Machine Cycle:	1
Operation:	$ACC \leftarrow (R) - (ACC)$
Description:	The contents of the ACC are binary subtracted from the contents of the data memory location addressed by R6 to R0 and the result is loaded into the ACC.
Flag Affected:	CF & ZF



Instruction Set Table 2, continued

<b>SUB WR , #I</b>	<b>Subtract immediate data from WR</b>
Machine Code:	<div style="display: flex; align-items: center; gap: 20px;"> <div style="border: 1px solid black; padding: 2px 10px;">0 0 0 1 1 1 1 0</div> <div style="border: 1px solid black; padding: 2px 10px;">I3 I2 I1 I0 W3 W2 W1 W0</div> </div>
Machine Cycle:	1
Operation:	$ACC \leftarrow (WR) - I$
Description:	The immediate data I are binary subtracted from the contents of the WR and the result is loaded into the ACC.
Flag Affected:	CF & ZF
<b>SUBR R, ACC</b>	<b>Subtract ACC from R</b>
Machine Code:	<div style="display: flex; align-items: center; gap: 20px;"> <div style="border: 1px solid black; padding: 2px 10px;">0 0 0 1 1 0 1 1</div> <div style="border: 1px solid black; padding: 2px 10px;">0 R6 R5 R4 R3 R2 R1 R0</div> </div>
Machine Cycle:	1
Operation:	$ACC, R \leftarrow (R) - (ACC)$
Description:	The contents of the ACC are binary subtracted from the contents of the data memory location addressed by R6 to R0 and the result is placed in the ACC and the data memory.
Flag Affected:	CF & ZF
<b>SUBR WR , #I</b>	<b>Subtract immediate data from WR</b>
Machine Code:	<div style="display: flex; align-items: center; gap: 20px;"> <div style="border: 1px solid black; padding: 2px 10px;">0 0 0 1 1 1 1 1</div> <div style="border: 1px solid black; padding: 2px 10px;">I3 I2 I1 I0 W3 W2 W1 W0</div> </div>
Machine Cycle:	1
Operation:	$ACC, WR \leftarrow (WR) - I$
Description:	The immediate data I are binary subtracted from the contents of the WR and the result is placed in the ACC and the WR.
Flag Affected:	CF & ZF



Instruction Set Table 2, continued

<b>XRL R, ACC</b>	<b>Exclusive OR R to ACC</b>		
<p>Machine Code:</p> <p>Machine Cycle:</p> <p>Operation:</p> <p>Description:</p> <p>Flag Affected:</p>	<table border="1"> <tr> <td>0 0 1 1 1 0 0 0</td> <td>0 R6 R5 R4 R3 R2 R1 R0</td> </tr> </table> <p>1</p> <p><math>ACC \leftarrow (R) \text{ EX } (ACC)</math></p> <p>The contents of the data memory location addressed by R6 to R0 and the ACC are exclusive-ORed and the result is loaded into the ACC.</p> <p>ZF</p>	0 0 1 1 1 0 0 0	0 R6 R5 R4 R3 R2 R1 R0
0 0 1 1 1 0 0 0	0 R6 R5 R4 R3 R2 R1 R0		
<b>XRL WR, #I</b>	<b>Exclusive OR immediate data to WR</b>		
<p>Machine Code:</p> <p>Machine Cycle:</p> <p>Operation:</p> <p>Description:</p> <p>Flag Affected:</p>	<table border="1"> <tr> <td>0 0 1 1 1 1 0 0</td> <td>I3 I2 I1 I0 W3 W2 W1 W0</td> </tr> </table> <p>1</p> <p><math>ACC \leftarrow (WR) \text{ EX } I</math></p> <p>The contents of the Working Register (WR) and the immediate data I are exclusive-ORed and the result is loaded into the ACC.</p> <p>ZF</p>	0 0 1 1 1 1 0 0	I3 I2 I1 I0 W3 W2 W1 W0
0 0 1 1 1 1 0 0	I3 I2 I1 I0 W3 W2 W1 W0		
<b>XRLR R, ACC</b>	<b>Exclusive OR R to ACC</b>		
<p>Machine Code:</p> <p>Machine Cycle:</p> <p>Operation:</p> <p>Description:</p> <p>Flag Affected:</p>	<table border="1"> <tr> <td>0 0 1 1 1 0 0 1</td> <td>0 R6 R5 R4 R3 R2 R1 R0</td> </tr> </table> <p>1</p> <p><math>ACC, R \leftarrow (R) \text{ EX } (ACC)</math></p> <p>The contents of the data memory location addressed by R6 to R0 and the ACC are exclusive-ORed and the result is placed in the data memory and the ACC.</p> <p>ZF</p>	0 0 1 1 1 0 0 1	0 R6 R5 R4 R3 R2 R1 R0
0 0 1 1 1 0 0 1	0 R6 R5 R4 R3 R2 R1 R0		



Instruction Set Table 2, continued

<b>XRLR WR, #I</b>	<b>Exclusive OR immediate data to WR</b>
Machine Code:	<div style="display: flex; justify-content: space-around; align-items: center;"> <div style="border: 1px solid black; padding: 2px 10px;">0 0 1 1 1 1 0 1</div> <div style="border: 1px solid black; padding: 2px 10px;">I3 I2 I1 I0 W3 W2 W1 W0</div> </div>
Machine Cycle:	1
Operation:	ACC, WR ← (WR) EX I
Description:	The contents of the Working Register(WR) and the immediate data I are exclusive-ORed and the result is placed in the WR and the ACC.
Flag Affected:	ZF

## PACKAGE DIMENSION

### 80-Lead QFP

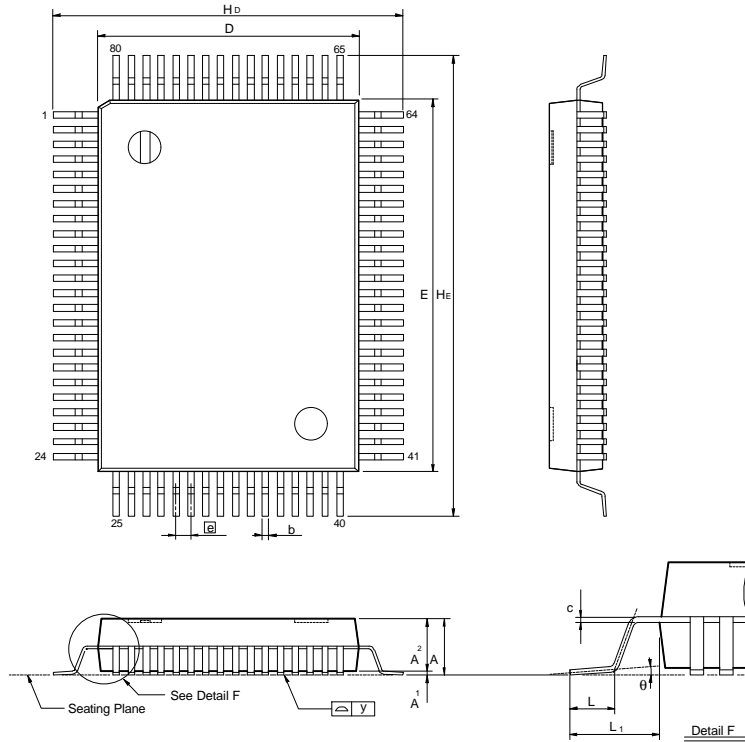

Symbol	Dimension in Inches			Dimension in mm		
	Min.	Nom.	Max.	Min.	Nom.	Max.
A	—	—	0.130	—	—	3.30
A <sub>1</sub>	0.004	—	—	0.10	—	—
A <sub>2</sub>	0.107	0.112	0.117	2.73	2.85	2.97
b	0.012	0.014	0.018	0.30	0.35	0.45
c	0.004	0.006	0.010	0.10	0.15	0.25
D	0.546	0.551	0.556	13.87	14.00	14.13
E	0.782	0.787	0.792	19.87	20.00	20.13
$\bar{e}$	0.025	0.031	0.037	0.65	0.80	0.95
H <sub>D</sub>	0.728	0.740	0.752	18.49	18.80	19.10
H <sub>E</sub>	0.964	0.976	0.988	24.49	24.80	25.10
L	0.039	0.047	0.055	1.00	1.20	1.40
L <sub>1</sub>	0.087	0.094	0.103	2.21	2.40	2.62
y	—	—	0.004	—	—	0.10
$\theta$	0°	—	12°	0°	—	12°



**Notes:**



#### **Headquarters**

No. 4, Creation Rd. III,  
Science-Based Industrial Park,  
Hsinchu, Taiwan  
TEL: 886-3-5770066  
FAX: 886-3-5792766  
<http://www.winbond.com.tw/>  
Voice & Fax-on-demand: 886-2-27197006

#### **Taipei Office**

11F, No. 115, Sec. 3, Min-Sheng East Rd.,  
Taipei, Taiwan  
TEL: 886-2-27190505  
FAX: 886-2-27197502

#### **Winbond Electronics (H.K.) Ltd.**

Rm. 803, World Trade Square, Tower II,  
123 Hoi Bun Rd., Kwun Tong,  
Kowloon, Hong Kong  
TEL: 852-27513100  
FAX: 852-27552064

#### **Winbond Electronics North America Corp.**

**Winbond Memory Lab.**  
**Winbond Microelectronics Corp.**  
**Winbond Systems Lab.**  
2727 N. First Street, San Jose,  
CA 95134, U.S.A.  
TEL: 408-9436666  
FAX: 408-5441798

---

Note: All data and specifications are subject to change without notice.