



W83194R-67B

100MHZ 3-DIMM CLOCK FOR VIA MVP4

1.0 GENERAL DESCRIPTION

The W83194R-67B is a Clock Synthesizer which provides all clocks required for high-speed RISC or CISC microprocessor such as Intel Pentium , AMD and Cyrix. W83194R-67B provides sixteen CPU/PCI frequencies which are externally selectable with smooth transitions. W83194R-67B also provides 13 SDRAM clocks controlled by the none-delay buffer_in pin.

The W83194R-67B accepts a 14.318 MHz reference crystal as its input and runs on a 3.3V supply. Spread spectrum built in at $\pm 0.5\%$ or $\pm 0.25\%$ to reduce EMI. Programmable stopping individual clock outputs and frequency selection through I²C interface. The device meets the Pentium power-up stabilization, which requires CPU and PCI clocks be stable within 2 ms after power-up.

High drive six PCI and thirteen SDRAM CLOCK outputs typically provide greater than 1 V /ns slew rate into 30 pF loads. Two CPU CLOCK outputs typically provide better than 1 V /ns slew rate into 20 pF loads as maintaining 50 \pm 5% duty cycle. The fixed frequency outputs as REF, 24MHz, and 48 MHz provide better than 0.5V /ns slew rate.

2.0 PRODUCT FEATURES

- Supports Pentium™ , AMD, Cyrix CPU with I²C.
- 4 CPU clocks (one free-running CPU clock)
- 13 SDRAM clocks for 3 DIMs
- 6 PCI synchronous clocks
- Optional single or mixed supply:
(Vddq1=Vddq2 = Vddq3 = Vddq4 = VddL1 =VddL2= 3.3V) or (Vddq1= Vddq2 = Vddq3=Vddq4 = 3.3V, VddL1 = VddL2 = 2.5V)
- < 250ps skew among CPU and SDRAM clocks
- < 4ns propagation delay SDRAM from buffer input
- Skew from CPU(earlier) to PCI clock -1 to 4ns, center 2.6ns.
- Smooth frequency switch with selections from 60 MHz to 124 MHz CPU
- I²C 2-Wire serial interface and I²C read back
- 0~0.5% down type or $\pm 0.25\%$ or $\pm 0.5\%$ spread spectrum function to reduce EMI
- Programmable registers to enable/stop each output and select modes (mode as Tri-state or Normal)
- 2ms power up clock stable time
- MODE pin for power Management
- One 48 MHz for USB & one 24 MHz for super I/O
- Packaged in 48-pin SSOP



3.0 BLOCK DIAGRAM

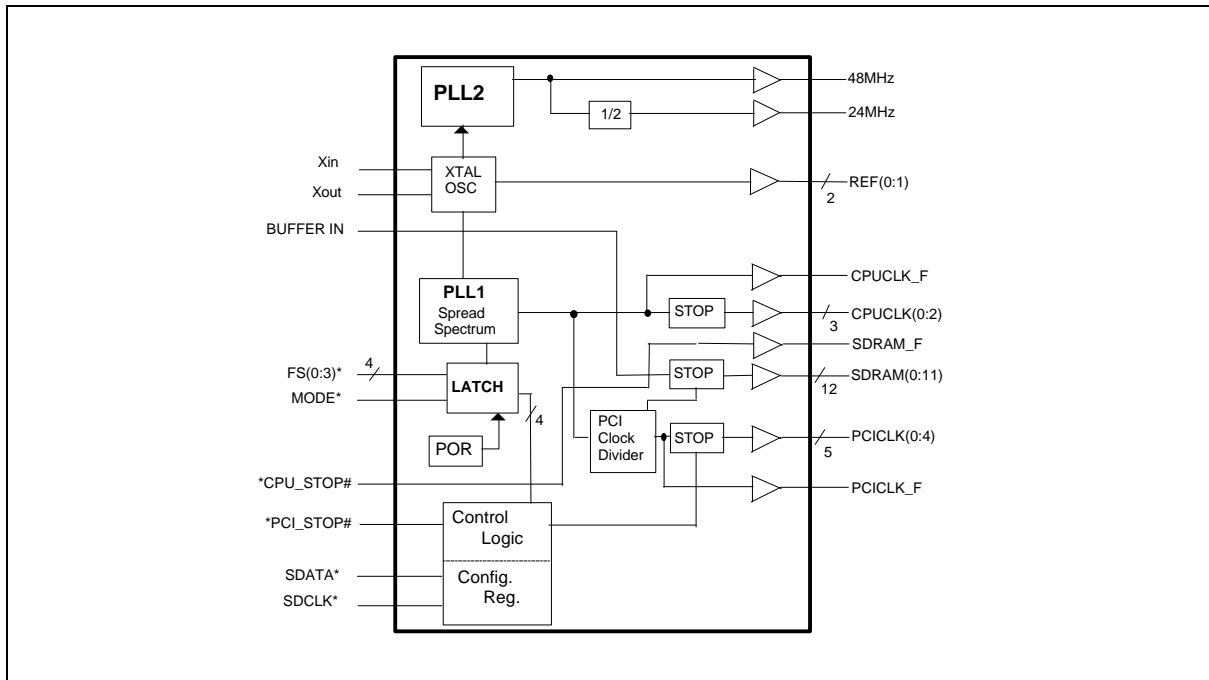

4.0 PIN CONFIGURATION

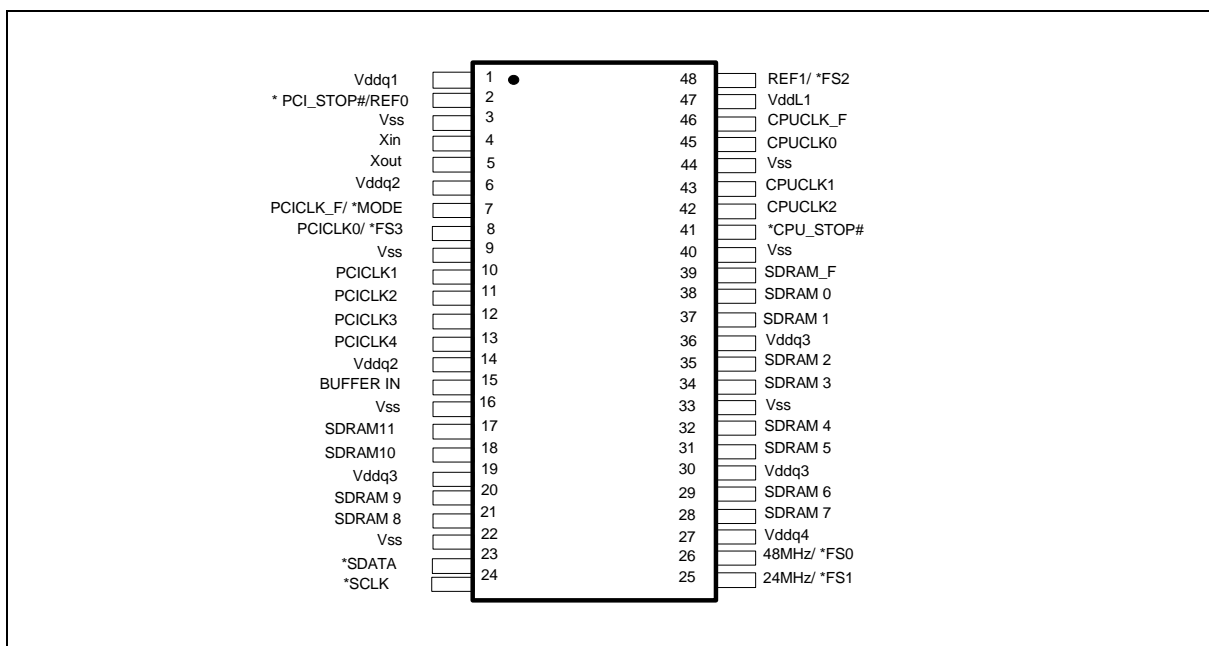



PRELIMINARY

5.0 PIN DESCRIPTION

IN - Input

OUT - Output

I/O - Bi-directional Pin

- Active Low

* - Internal 250kΩ pull-up

5.1 Crystal I/O

SYMBOL	PIN	I/O	FUNCTION
Xin	4	IN	Crystal input with internal loading capacitors and feedback resistors.
Xout	5	OUT	Crystal output at 14.318MHz nominally.

5.2 CPU, SDRAM, PCI, IOAPIC Clock Outputs

SYMBOL	PIN	I/O	FUNCTION
CPUCLK_F	46	OUT	Free running CPU clock. Not affected by CPU_STOP#
CPUCLK[0:2]	45,43,42	OUT	Low skew (< 250ps) clock outputs for host frequencies such as CPU, Chipset and Cache. Powered by VddL2. Low if CPU_STOP# is low.
*CPU_STOP#	41	IN	This asynchronous input halts CPUCLK[0:2] and SDRAM(0:11) at logic level when driven low.
SDRAM_F	39	OUT	Free running SDRAM clock. Not affected by CPU_STOP#
SDRAM [0:11]	17,18,20,21,28,29,31,32,34,35,37,38	OUT	SDRAM clock outputs. Fanout buffer outputs from BUFFER IN pin.(Controlled by chipset)
PCICLK_F/ *MODE	7	I/O	Free running PCI clock during normal operation. Latched Input. Mode=1, Pin 2 is REF0; Mode=0, Pin2 is PCI_STOP#
PCICLK0/*FS3	8	I/O	Low skew (< 250ps) PCI clock outputs. Latched input for FS3 at initial power up for H/W selecting the output frequency of CPU, SDRAM and PCI clocks.
PCICLK [1:4]	10,11,12,13	OUT	Low skew (< 250ps) PCI clock outputs. Synchronous to CPU clocks with 1/-4ns skew(CPU early).
BUFFER IN	15	IN	Inputs to fanout for SDRAM outputs.

W83194R-67B



PRELIMINARY

5.3 I²C Control Interface

SYMBOL	PIN	I/O	FUNCTION
*SDATA	23	I/O	Serial data of I ² C 2-wire control interface with internal pull-up resistor.
*SDCLK	24	IN	Serial clock of I ² C 2-wire control interface with internal pull-up resistor.

5.4 Fixed Frequency Outputs

SYMBOL	PIN	I/O	FUNCTION
REF0 / *PCI_STOP#	2	I/O	14.318MHz reference clock. This REF output is the stronger buffer for ISA bus loads. Halt PCICLK(0:4) clocks at logic 0 level, when input low (In mobile mode. MODE=0)
REF1 / *FS2	48	I/O	14.318MHz reference clock. Latched input for FS2 at initial power up for H/W selecting the output frequency of CPU, SDRAM and PCI clocks.
24MHz / *FS1	25	I/O	24MHz output clock. Latched input for FS1 at initial power up for H/W selecting the output frequency of CPU, SDRAM and PCI clocks.
48MHz / *FS0	26	I/O	48MHz output for USB during normal operation. Latched input for FS0 at initial power up for H/W selecting the output frequency of CPU, SDRAM and PCI clocks.

5.5 Power Pins

SYMBOL	PIN	FUNCTION
Vddq1	1	Power supply for Ref [0:1] , Xin and Xout crystal.
VddL1	47	Power supply for CPU clock outputs, either 2.5V or 3.3V.
Vddq2	6, 14	Power supply for PCICLK_F, PCICLK[1:4], 3.3V.
Vddq3	19, 30, 36	Power supply for SDRAM_F, SDRAM[0:11], and PLL core, nominal 3.3V.
Vddq4	27	Power for 24 & 48MHz output buffers and PLL core.
Vss	3,9,16,22,33,40,44	Circuit Ground.



PRELIMINARY

6.0 FREQUENCY SELECTION

FS3	FS2	FS1	FS0	CPU,SDRAM(MHz)	PCI(MHz)	REF,IOAPIC (MHz)
1	1	1	1	60	30(CPU/2)	14.318
1	1	1	0	66.8	33.4(CPU/2)	14.318
1	1	0	1	70	35(CPU/2)	14.318
1	1	0	0	90	30(CPU/3)	14.318
1	0	1	1	97.0	32.33(CPU/3)	14.318
1	0	1	0	83.3	27.77(CPU/3)	14.318
1	0	0	1	95.25	31.75(CPU/3)	14.318
1	0	0	0	100.2	33.3(CPU/3)	14.318
0	1	1	1	75	37.5(CPU/2)	14.318
0	1	1	0	80	40(CPU/2)	14.318
0	1	0	1	83.3	41.65(CPU/2)	14.318
0	1	0	0	105	35(CPU/3)	14.318
0	0	1	1	110	36.67(CPU/3)	14.318
0	0	1	0	115	38.33(CPU/3)	14.318
0	0	0	1	124	31(CPU/4)	14.318
0	0	0	0	133	33.3(CPU/4)	14.318

7.0 MODE PIN -POWER MANAGEMENT INPUT CONTROL

MODE, Pin7 (Latched Input)	PIN 2
0	PCI_STOP# (Input)
1	REF0 (Output)



PRELIMINARY

8.0 FUNCTION DESCRIPTION

8.1 POWER MANAGEMENT FUNCTIONS

All clocks can be individually enabled or disabled via the 2-wire control interface. On power up, external circuitry should allow 3 ms for the VCO to stabilize prior to enabling clock outputs to assure correct pulse widths. When MODE=0, pins 15 and 46 are inputs (PCI_STOP#), (CPU_STOP#), when MODE=1, these functions are not available. A particular clock could be enabled as both the 2-wire serial control interface and one of these pins indicate that it should be enable.

The W83194R-67B may be disabled in the low state according to the following table in order to reduce power consumption. All clocks are stopped in the low state, but maintain a valid high period on transitions from running to stop. The CPU and PCI clocks transform between running and stop by waiting for one positive edge on PCICLK_F followed by negative edge on the clock of interest, after which high levels of the output are either enabled or disabled.

CPU_STOP#	PCI_STOP#	CPUCLK 0:2, SDRAM 0:11	PCI	SDRAM_F, CPU_F,PCI_F	OTHER CLKs
0	0	LOW	LOW	RUNNING	RUNNING
0	1	LOW	RUNNING	RUNNING	RUNNING
1	0	RUNNING	LOW	RUNNING	RUNNING
1	1	RUNNING	RUNNING	RUNNING	RUNNING

8.2 2-WIRE I²C CONTROL INTERFACE

The clock generator is a slave I²C component which can be read back? The data stored in the latches for verification. All proceeding bytes must be sent to change one of the control bytes. The 2-wire control interface allows each clock output individually enabled or disabled. On power up, the W83194R-67B initializes with default register settings, and then it is optional to use the 2-wire control interface.

The SDATA signal only changes when the SDCLK signal is low, and is stable when SDCLK is high during normal data transfer. There are only two exceptions. One is a high-to-low transition on SDATA while SDCLK is high used to indicate the beginning of a data transfer cycle. The other is a low-to-high transition on SDATA while SDCLK is high used to indicate the end of a data transfer cycle. Data is always sent as complete 8-bit bytes followed by an acknowledge generated.

Byte writing starts with a start condition followed by 7-bit slave address and a write command bit [1101 0010], command code checking [0000 0000], and byte count checking. After successful reception of each byte, an acknowledge (low) on the SDATA wire will be generated by the clock chip. Controller can start to write to internal I²C registers after the string of data. The sequence order is as follows:



PRELIMINARY

Bytes sequence order for I²C controller :

Clock Address A(6:0) & R/W	Ack	8 bits dummy Command code	Ack	8 bits dummy Byte count	Ack	Byte0,1,2... until Stop
-------------------------------	-----	------------------------------	-----	----------------------------	-----	----------------------------

Set R/W to 1 when read back the data sequence is as follows :

Clock Address A(6:0) & R/W	Ack	Byte 0	Ack	Byte 1	Ack	Byte2, 3, 4... until Stop
-------------------------------	-----	--------	-----	--------	-----	------------------------------

8.3 SERIAL CONTROL REGISTERS

The Pin column lists the affected pin number and the @PowerUp column gives the default state at true power up. "Command Code" byte and "Byte Count" byte must be sent following the acknowledge of the Address Byte. Although the data (bits) in these two bytes are considered "don't care", they must be sent and will be acknowledge. After that, the below described sequence (Register 0, Register 1, Register 2,) will be valid and acknowledged.

8.3.1 Register 0: CPU Frequency Select Register (default = 0)

Bit	@PowerUp	Pin	Description
7	0	-	0 = ±0.25% Center type Spread Spectrum Modulation 1 = ±0.5% Center type Spread Spectrum Modulation
6	0	-	SSEL2 (for frequency table selection by software via I ² C)
5	0	-	SSEL1 (for frequency table selection by software via I ² C)
4	0	-	SSEL0 (for frequency table selection by software via I ² C)
3	0	-	0 = Selection by hardware 1 = Selection by software I ² C - Bit 2, 6:4
2	0	-	SSEL3 (for frequency table selection by software via I ² C)
1	0	-	0 = Normal 1 = Spread Spectrum enabled
0	0	-	0 = Running 1 = Tristate all outputs

W83194R-67B



PRELIMINARY

Frequency table by I2C

SSEL3	SSEL2	SSEL1	SSEL0	CPU,SDRAM(MHz)	PCI(MHz)	REF,IOAPIC (MHz)
1	1	1	1	60	30(CPU/2)	14.318
1	1	1	0	66.8	33.4(CPU/2)	14.318
1	1	0	1	70	35(CPU/2)	14.318
1	1	0	0	90	30(CPU/3)	14.318
1	0	1	1	97.0	32.33(CPU/3)	14.318
1	0	1	1	80	26.67(CPU/3)	14.318
1	0	1	0	83.3	27.77(CPU/3)	14.318
1	0	0	1	95.25	31.75(CPU/3)	14.318
1	0	0	0	100.2	33.3(CPU/3)	14.318
0	1	1	1	75	37.5(CPU/2)	14.318
0	1	1	0	80	40(CPU/2)	14.318
0	1	0	1	83.3	41.65(CPU/2)	14.318
0	1	0	0	105	35(CPU/3)	14.318
0	0	1	1	110	36.67(CPU/3)	14.318
0	0	1	0	115	38.33(CPU/3)	14.318
0	0	0	1	124	31(CPU/4)	14.318
0	0	0	0	133	33.3(CPU/4)	14.318

8.3.2 Register 1 : CPU Clock Register (1 = Active, 0 = Inactive)

Bit	@PowerUp	Pin	Description
7	x	-	Latched FS2#
6	1	-	0 = 0.5% down type spread, overrides Byte0-bit7. 1= Center type spread.
5	1	-	Reserved
4	1	-	Reserved
3	1	42	CPUCLK2 (Active / Inactive)
2	1	43	CPUCLK1 (Active / Inactive)
1	1	45	CPUCLK0 (Active / Inactive)
0	1	46	CPUCLK_F (Active / Inactive)



PRELIMINARY

8.3.3 Register 2: PCI Clock Register (1 = Active, 0 = Inactive)

Bit	@PowerUp	Pin	Description
7	1	-	Reserved
6	1	7	PCICLK_F (Active / Inactive)
5	1	-	Reserved
4	1	13	PCICLK4 (Active / Inactive)
3	1	12	PCICLK3 (Active / Inactive)
2	1	11	PCICLK2 (Active / Inactive)
1	1	10	PCICLK1 (Active / Inactive)
0	1	8	PCICLK0 (Active / Inactive)

8.3.4 Register 3: SDRAM Clock Register (1 = Active, 0 = Inactive)

Bit	@PowerUp	Pin	Description
7	1	-	Reserved
6	x	-	Latched FS0#
5	1	26	48MHz (Active / Inactive)
4	1	25	24MHz (Active / Inactive)
3	1	39	SDRAM_F(Active / Inactive)
2	1	21,20,18,17	SDRAM(8:11) (Active / Inactive)
1	1	32,31,29,28	SDRAM(4:7) (Active / Inactive)
0	1	38,37,35,34	SDRAM(0:3) (Active / Inactive)

8.3.5 Register 4: Reserved Register (1 = Active, 0 = Inactive)

Bit	@PowerUp	Pin	Description
7	1	-	Reserved
6	1	-	Reserved
5	1	-	Reserved
4	1	-	Reserved
3	x	-	Latched FS1#
2	1	-	Reserved
1	x	-	Latched FS3#
0	1	-	Reserved

W83194R-67B



PRELIMINARY

8.3.6 Register 5: Peripheral Control (1 = Active, 0 = Inactive)

Bit	@PowerUp	Pin	Description
7	1	-	Reserved
6	1	-	Reserved
5	1	-	Reserved
4	1	-	Reserved
3	1	-	Reserved
2	1	-	Reserved
1	1	48	REF1 (Active / Inactive)
0	1	2	REF0 (Active / Inactive)

8.3.7 Register 6: Winbond Chip ID Register (Read Only)

Bit	@PowerUp	Pin	Description
7	0	-	Winbond Chip ID
6	1	-	Winbond Chip ID
5	0	-	Winbond Chip ID
4	1	-	Winbond Chip ID
3	1	-	Winbond Chip ID
2	0	-	Winbond Chip ID
1	0	-	Winbond Chip ID
0	0	-	Winbond Chip ID

NOTE:

1. Inactive means outputs are held LOW and are disabled from switching.
2. Latched Frequency Selects (FS#) will be inverted logic load of the input frequency select pin conditions.



PRELIMINARY

9.0 SPECIFICATIONS

9.1 ABSOLUTE MAXIMUM RATINGS

Stresses greater than those listed in this table may cause permanent damage to the device. Precautions should be taken to avoid application of any voltage higher than the maximum rated voltages to this circuit. Maximum conditions for extended periods may affect reliability. Unused inputs must always be tied to an appropriate logic voltage level (Ground or Vdd).

Symbol	Parameter	Rating
Vdd , VIN	Voltage on any pin with respect to GND	- 0.5 V to + 7.0 V
T _{STG}	Storage Temperature	- 65°C to + 150°C
T _B	Ambient Temperature	- 55°C to + 125°C
T _A	Operating Temperature	0°C to + 70°C

9.2 AC CHARACTERISTICS

Vddq1=Vddq2 = Vddq3 = Vddq4 =3.3V , VddL1 =VddL2= 2.5V , T _A = 0° C to +70° C						
Parameter	Symbol	Min	Typ	Max	Units	Test Conditions
Output Duty Cycle		45	50	55	%	Measured at 1.5V
CPU/SDRAM to PCI Offset	t _{OFF}	1		4	ns	15 pF Load Measured at 1.5V
Skew (CPU-CPU), (PCI-PCI), (SDRAM-SDRAM)	t _{SKEW}			250	ps	15 pF Load Measured at 1.5V
CPU/SDRAM Cycle to Cycle Jitter	t _{CCJ}			±250	ps	
CPU/SDRAM Absolute Jitter	t _{JA}			500	ps	
Jitter Spectrum 20 dB Bandwidth from Center	BW _J			500	KHz	
Output Rise (0.4V ~ 2.0V) & Fall (2.0V ~0.4V) Time	t _{TLH} t _{THL}	0.4		1.6	ns	15 pF Load on CPU and PCI outputs
Overshoot/Undershoot Beyond Power Rails	V _{over}			1.5	V	22 Ω at source of 8 inch PCB run to 15 pF load
Ring Back Exclusion	V _{RBE}			2.1	V	Ring Back must not enter this range.

9.3 DC CHARACTERISTICS

Vddq1=Vddq2 = Vddq3 = Vddq4 =3.3V, VddL1 =VddL2= 2.5V , $T_A = 0^\circ\text{C to }+70^\circ\text{C}$						
Parameter	Symbol	Min	Typ	Max	Units	Test Conditions
Input Low Voltage	V_{IL}			0.8	V_{dc}	
Input High Voltage	V_{IH}	2.0			V_{dc}	
Input Low Current	I_{IL}			-66	μA	
Input High Current	I_{IH}			5	μA	
Output Low Voltage $I_{OL} = 4\text{ mA}$	V_{OL}			0.4	V_{dc}	All outputs
Output High Voltage $I_{OH} = 4\text{ mA}$	V_{OH}	2.4			V_{dc}	All outputs using 3.3V power
Tri-State leakage Current	I_{oz}			10	μA	
Dynamic Supply Current for Vdd + Vddq3	I_{dd3}				mA	CPU = 66.6 MHz PCI = 33.3 Mhz with load
Dynamic Supply Current for Vddq2 + Vddq2b	I_{dd2}				mA	Same as above
CPU Stop Current for Vdd + Vddq3	I_{CPUS3}				mA	Same as above
CPU Stop Current for Vddq2 + Vddq2b	I_{CPUS2}				mA	Same as above
PCI Stop Current for Vdd + Vddq3	I_{PD3}				mA	



PRELIMINARY

9.4 BUFFER CHARACTERISTICS

9.4.1 TYPE 1 BUFFER FOR CPU CLOCK

Parameter	Symbol	Min	Typ	Max	Units	Test Conditions
Pull-Up Current Min	I _{OH(min)}	-27			mA	V _{out} = 1.0 V
Pull-Up Current Max	I _{OH(max)}			-27	mA	V _{out} = 2.0V
Pull-Down Current Min	I _{OL(min)}				mA	V _{out} = 1.2 V
Pull-Down Current Max	I _{OL(max)}			27	mA	V _{out} = 0.3 V
Rise/Fall Time Min Between 0.4 V and 2.0 V	T _{RF(min)}	0.4			ns	10pF Load
Rise/Fall Time Max Between 0.4 V and 2.0 V	T _{RF(max)}			1.6	ns	20pF Load

9.4.2 TYPE 3 BUFFER FOR REF[0:1], 24MHZ, 48MHZ

Parameter	Symbol	Min	Typ	Max	Units	Test Conditions
Pull-Up Current Min	I _{OH(min)}	-29			mA	V _{out} = 1.0 V
Pull-Up Current Max	I _{OH(max)}			-23	mA	V _{out} = 3.135V
Pull-Down Current Min	I _{OL(min)}	29			mA	V _{out} = 1.95 V
Pull-Down Current Max	I _{OL(max)}				mA	V _{out} = 0.4 V
Rise/Fall Time Min Between 0.8 V and 2.0 V	T _{RF(min)}	1.0			ns	10pF Load
Rise/Fall Time Max Between 0.8 V and 2.0 V	T _{RF(max)}			4.0	ns	20pF Load

9.4.3 TYPE 4 BUFFER FOR SDRAM (F,0:11)

Parameter	Symbol	Min	Typ	Max	Units	Test Conditions
Pull-Up Current Min	I _{OH(min)}				mA	V _{out} = 1.65 V
Pull-Up Current Max	I _{OH(max)}			-46	mA	V _{out} = 3.135 V
Pull-Down Current Min	I _{OL(min)}				mA	V _{out} = 1.65 V
Pull-Down Current Max	I _{OL(max)}			53	mA	V _{out} = 0.4 V
Rise/Fall Time Min Between 0.8 V and 2.0 V	T _{RF(min)}	0.5			ns	20pF Load
Rise/Fall Time Max Between 0.8 V and 2.0 V	T _{RF(max)}			1.3	ns	30pF Load

9.4.4 TYPE 5 BUFFER FOR PCICLK(0:4,F)

Parameter	Symbol	Min	Typ	Max	Units	Test Conditions
Pull-Up Current Min	$I_{OH(min)}$	-33			mA	$V_{out} = 1.0\text{ V}$
Pull-Up Current Max	$I_{OH(max)}$			-33	mA	$V_{out} = 3.135\text{ V}$
Pull-Down Current Min	$I_{OL(min)}$	30			mA	$V_{out} = 1.95\text{ V}$
Pull-Down Current Max	$I_{OL(max)}$			38	mA	$V_{out} = 0.4\text{ V}$
Rise/Fall Time Min Between 0.8 V and 2.0 V	$T_{RF(min)}$	0.5			ns	15pF Load
Rise/Fall Time Max Between 0.8 V and 2.0 V	$T_{RF(max)}$			2.0	ns	30pF Load



10.0 POWER MANAGEMENT TIMING

10.1 CPU_STOP# Timing Diagram

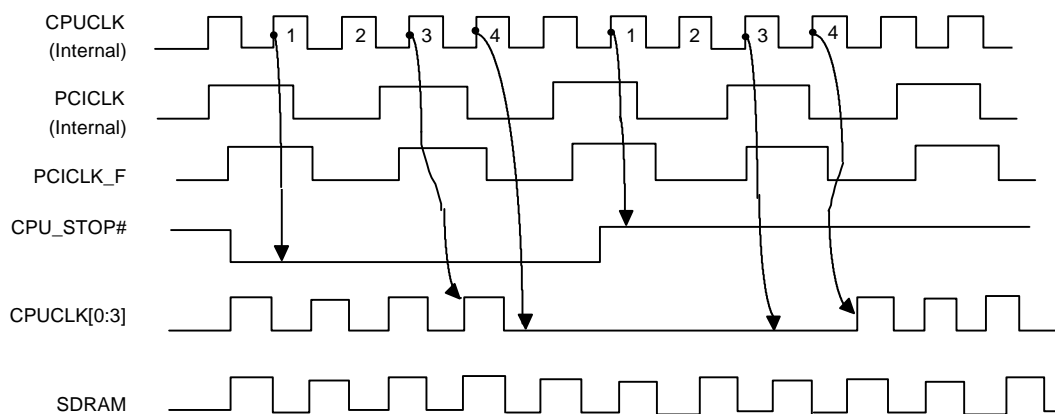

For synchronous Chipset, CPU_STOP# pin is an asynchronous “ active low ” input pin used to stop the CPU clocks for low power operation. This pin is asserted synchronously by the external control logic at the rising edge of free running PCI clock(PCICLK_F). All other clocks will continue to run while the CPU clocks are stopped. The CPU clocks will always be stopped in a low state and resume output with full pulse width. In this case, CPU “locks on latency” is less than 4 CPU clocks and “locks off latency” is less than 4 CPU clocks.

10.2 PCI_STOP# Timing Diagram

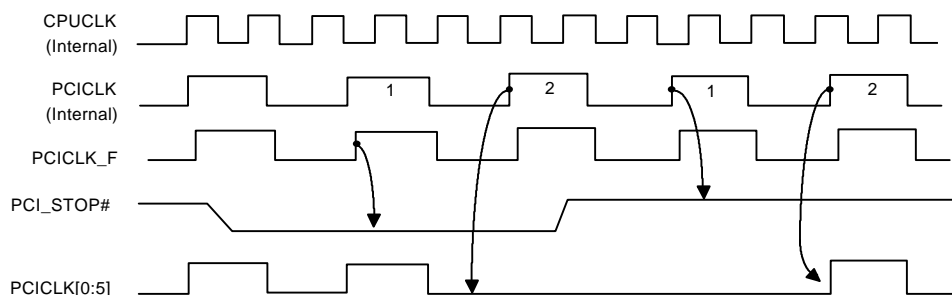

For synchronous Chipset, PCI_STOP# pin is an asynchronous “ active low ” input pin used to stop the PCICLK [0:4] for low power operation. This pin is asserted synchronously by the external control logic at the rising edge of free running PCI clock(PCICLK_F). All other clocks will continue to run while the PCI clocks are stopped. The PCI clocks will always be stopped in a low state and resume output with full pulse width. In this case, PCI “locks on latency” is less than 2 PCI clocks and “locks off latency” is less than 2 PCI clocks.

11.0 OPERATION OF DUAL FUNCTION PINS

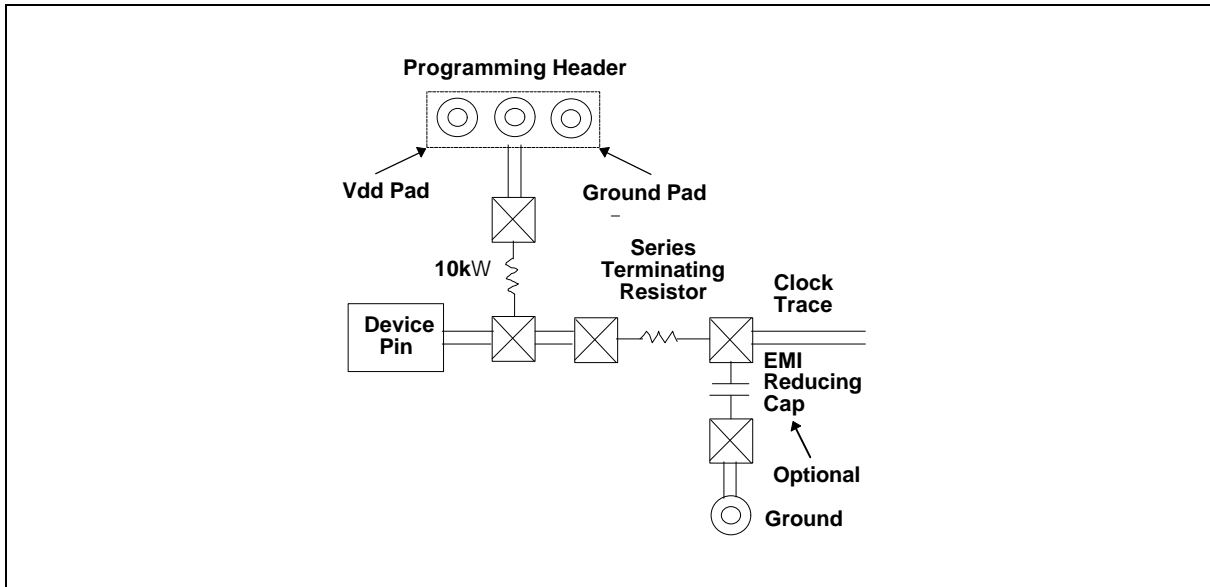
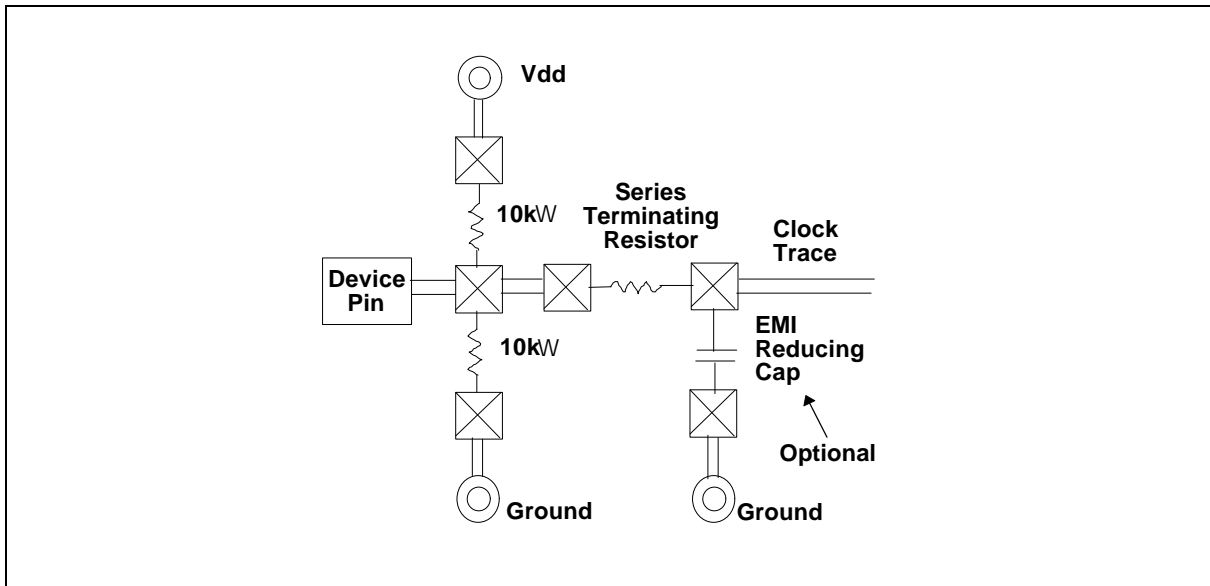

W83194R-67B



PRELIMINARY

12.0 ORDERING INFORMATION

Part Number	Package Type	Production Flow
W83194R-67B	48 PIN SSOP	Commercial, 0°C to +70°C

13.0 HOW TO READ THE TOP MARKING

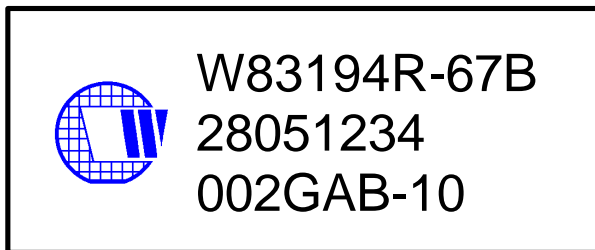

1st line: Winbond logo and the type number: W83194R-67B

2nd line: Tracking code 2 8051234

2: wafers manufactured in Winbond FAB 2

8051234: wafer production series lot number

3rd line: Tracking code 002 G A B

002: packages made in '00, week 02

G: assembly house ID; A means ASE, S means SPIL, G means GR

AB: IC revision

All the trade marks of products and companies mentioned in this data sheet belong to their respective owners.

W83194R-67B



PRELIMINARY

14.0 PACKAGE DRAWING AND DIMENSIONS

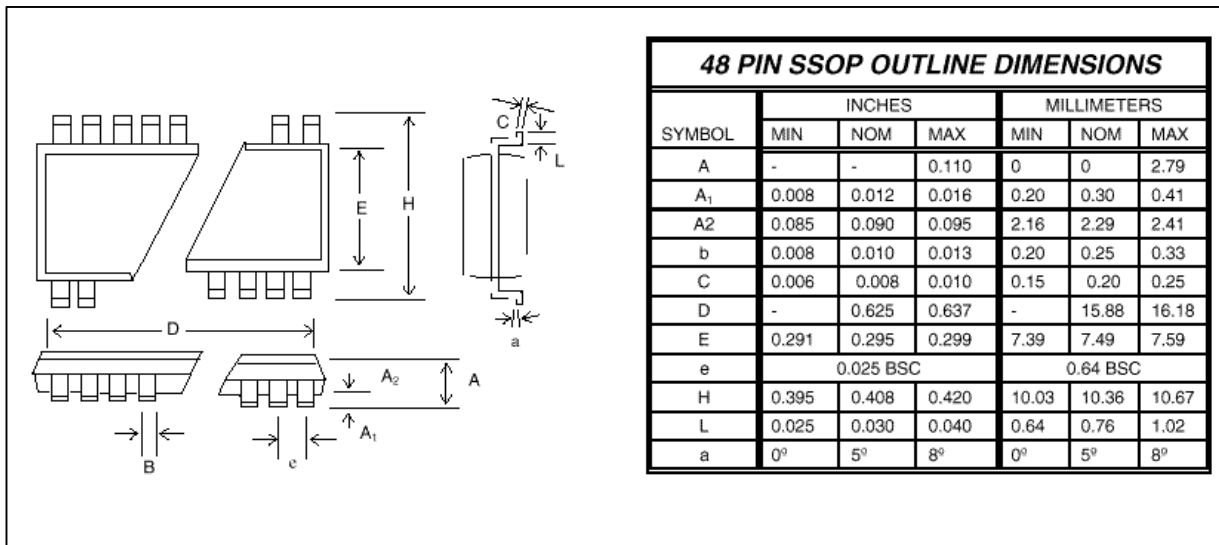

Headquarters
 No. 4, Creation Rd. III
 Science-Based Industrial Park
 Hsinchu, Taiwan
 TEL: 886-35-770066
 FAX: 886-35-789467
 www: <http://www.winbond.com.tw/>

Taipei Office
 11F, No. 115, Sec. 3, Min-Sheng East Rd.
 Taipei, Taiwan
 TEL: 886-2-7190505
 FAX: 886-2-7197502
 TLX: 16485 WINTPE

Winbond Electronics (H.K.) Ltd.
 Rm. 803, World Trade Square, Tower II
 123 Hoi Bun Rd., Kwun Tong
 Kowloon, Hong Kong
 TEL: 852-27516023-7
 FAX: 852-27552064

Winbond Electronics (North America) Corp.
 2730 Orchard Parkway
 San Jose, CA 95134 U.S.A.
 TEL: 1-408-9436666
 FAX: 1-408-9436668

Please note that all data and specifications are subject to change without notice. All the trade marks of products and companies mentioned in this data sheet belong to their respective owners.

These products are not designed for use in life support appliances, devices, or systems where malfunction of these products can reasonably be expected to result in personal injury. Winbond customers using or selling these products for use in such applications do so at their own risk and agree to fully indemnify Winbond for any damages resulting from such improper use or sale.