

# **W83971D**

## **AC'97 AUDIO CODEC**

## W83971D Data Sheet Revision History

	Pages	Dates	Version	Version on Web	Main Contents
1	n.a.	09/30/98	0.5	n.a.	First published.
2	n.a.	01/04/99	0.51	n.a.	Correct performance spec and app. circuit.
3	All	7/16/1999	0.52 0.55	n.a.	Add Layout guideline and reference schematic .
4					
5					
6					
7					
8					
9					
10					

*Please note that all data and specifications are subject to change without notice. All the trade marks of products and companies mentioned in this data sheet belong to their respective owners.*

### **LIFE SUPPORT APPLICATIONS**

*These products are not designed for use in life support appliances, devices, or systems where malfunction of these products can reasonably be expected to result in personal injury. Winbond customers using or selling these products for use in such applications do so at their own risk and agree to fully indemnify Winbond for any damages resulting from such improper use or sales.*



## AC'97 AUDIO CODEC

### *Table of Contents*

1. GENERAL DESCRIPTION .....	4
2. FEATURE LIST .....	4
3. FUNCTIONAL BLOCK DIAGRAM .....	5
4. PINOUT AND PACKAGE .....	6
5. PIN DESCRIPTION.....	8
5.1 Digital I/O .....	8
5.2 Analog I/O .....	8
5.3 Filter and Reference Pins.....	9
5.4 Power Supplies .....	9
6. REGISTER DESCRIPTION .....	10
6.1 Register Map.....	10
6.2 Reset Register (Index 00h) .....	11
6.3 Stereo Output Control Register (Index 02h) .....	11
6.3.1 Mute Stereo Output Mute Control .....	11
6.3.2 ML[5:0] Master Output (Left Channel) Volume Control .....	11
6.3.3 MR[5:0] Master Output (Right Channel) Volume Control .....	11
6.3.4 Output Volume Control Map.....	12
6.4 Mono Output Control Register (Index 06h).....	13
6.4.1 Mute Mono Output Mute Control .....	13
6.4.2 MM[5:0] Mono Output Volume Control .....	13
6.4.3 Stereo and Mono Output Attenuation .....	13
6.5 PC_BEEP Input Volume Control Register (Index 0Ah) .....	14
6.5.1 Mute PC Beep Input Mute Control .....	14
6.5.2 PV[3:0] PC Beep Input Volume Control .....	14
6.6 Phone Input Volume Control Register (Index 0Ch).....	14
6.6.1 Mute Phone Input Mute Control.....	14
6.6.2 GN[4:0] PC Phone Input Volume Control .....	14
6.6.3 Programmable Input and Output Gain Levels.....	15
6.7 Mic Input Volume Control Register (Index 0Eh) .....	16
6.7.1 Mute Mic Input Mute Control .....	16
6.7.2 20dB Mic Boost Control .....	16



6.7.3 GN[4:0] Mic Input Volume Control.....	16
6.8 Line Input Control Register (Index 10h).....	16
6.8.1 Mute Line Input Mute Control.....	16
6.8.2 GL[4:0] Left Channel Gain Control.....	16
6.8.3 GR[4:0] Right Channel Gain Control.....	17
6.9 CD Input Control Register (Index 12h).....	17
6.9.1 Mute Line Input Mute Control.....	17
6.9.2 GL[4:0] Left Channel Gain Control.....	17
6.9.3 GR[4:0] Right Channel Gain Control.....	17
6.10 Video Input Control Register (Index 14h).....	17
6.10.1 Mute Line Input Mute Control.....	17
6.10.2 6.10.2 GL[4:0] Left Channel Gain Control.....	18
6.10.3 GR[4:0] Right Channel Gain Control.....	18
6.11 Auxiliary Input Control Register (Index 16h).....	18
6.11.1 Mute Line Input Mute Control.....	18
6.11.2 GL[4:0] Left Channel Gain Control.....	18
6.11.3 GR[4:0] Right Channel Gain Control.....	18
6.12 PCM Output Control Register (Index 18h).....	19
6.12.1 Mute Line Input Mute Control.....	19
6.12.2 GL[4:0] Left Channel Gain Control.....	19
6.12.3 GR[4:0] Right Channel Gain Control.....	19
6.13 Record Select Register (Index 1Ah).....	19
6.13.1 Record Source Select(Left Channel)           Record Source Select(Right Channel).....	19
6.14 Record Gain Control Register (Index 1Ch).....	20
6.14.1 Mute Record Mute Control.....	20
6.14.2 GL[3:0] Record Gain Control (Left Channel).....	20
6.14.3 GR[3:0] Record Gain Control (Right Channel).....	20
6.15 General Purpose Register (Index 20h).....	20
6.15.1 3D Stereo Enhancement.....	20
6.15.2 MIX Mono Output Mode.....	20
6.15.3 MS Microphone Select.....	20
6.15.4 LPBK Loopback Mode.....	20
6.16 3D Control Register (Index 22h).....	21
6.16.1 Depth of 3D Control Level.....	21
6.17 Power Down and Status Register (Index 26h).....	21
6.17.1 PR[5:0] Power Down Mode Bits.....	21
6.17.2 Status (READ Only) bits.....	21
6.18 Vendor Identification Registers (Index 7Ch, 7Eh).....	22

# Preliminary W83971D



7. MULTIPLE CODEC EXTENSION .....	23
7.1 Multiple Codec Mode Select .....	23
7.2 Multiple Codec Example .....	24
8. ELECTRICAL SPECIFICATIONS .....	25
8.1 DC Characteristics .....	25
8.2 AC Timing Characteristics .....	25
8.3 BIT_CLK / SYNC .....	26
8.4 Setup and Hold .....	27
8.5 Rise and Fall .....	28
8.6 AC_Link Low Power Mode .....	29
8.7 ATE/ Vendor Test Mode .....	30
9. PERFORMANCE SPECIFICATIONS .....	31
9.1 Analog Characteristics .....	31
9.2 Miscellaneous Analog Performance Characteristics: .....	33
9.3 Power Consumption: .....	34
10. POWER MANAGEMENT .....	34
10.1 Power Down / Power Up .....	35
11. TEST MODE OPERATION .....	37
11.1 ATE Test Mode: .....	37
11.2 Vendor Test Mode: .....	37
12. TYPICAL CONNECTION DIAGRAM .....	38
13. HOW TO READ THE TOP MARKING .....	39
14. PACKAGE DIMENSIONS .....	40
15. APPENDIX A: TEST REPORT .....	41
16. APPENDIX B: LAYOUT GUIDE .....	54
16. APPENDIX B: LAYOUT GUIDE .....	55



## 1. GENERAL DESCRIPTION

The Winbond W83971D is a high performance codec compliant with Audio Codec'97 Rev1.03 requirements, in addition to 3D stereo enhancement. The definition of AC Link serial interface allows the W83971D to be used with DC97 controller as well as various digital controller which have AC Link interface.

Packaged in a small 48-pin LQFP , the W83971D can be placed on the motherboard, daughter board, add-on cards, PCMCIA cards, or outside the main chassis such as in speakers.

## 2. FEATURE LIST

- 16-bit stereo full-duplex codec with fixed 48KHz sampling rate
- S/N ratio: 85dB (analog to analog), 75dB(analog to digital), 85dB(digital to analog)
- Four analog line-level stereo inputs for connection from LINE IN, CD, VIDEO, and AUX
- Two analog line-level mono inputs for speakerphone and PC BEEP
- Mono mic input switchable from two external sources
- High quality pseudo-differential CD input
- Stereo line-level output
- Mono output for speakerphone
- 3D stereo enhancement
- Multiple Codec Support
- Power management support
- Single 5V supply or analog 5V, digital 3.3V
- Packaged in 48-pin LQFP

3. FUNCTIONAL BLOCK DIAGRAM

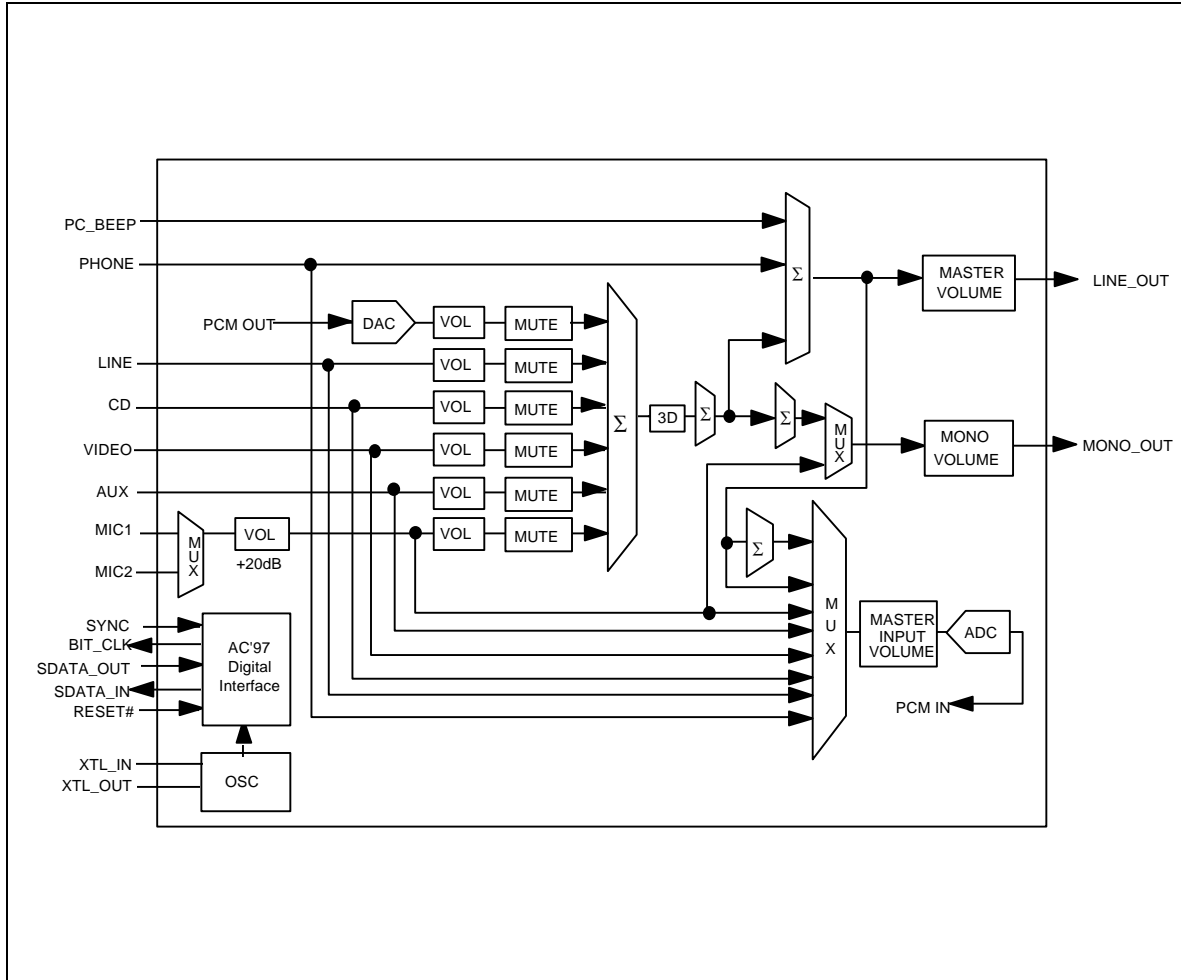

Figure 3.1: W83971D Functional Block Diagram

4. PINOUT AND PACKAGE

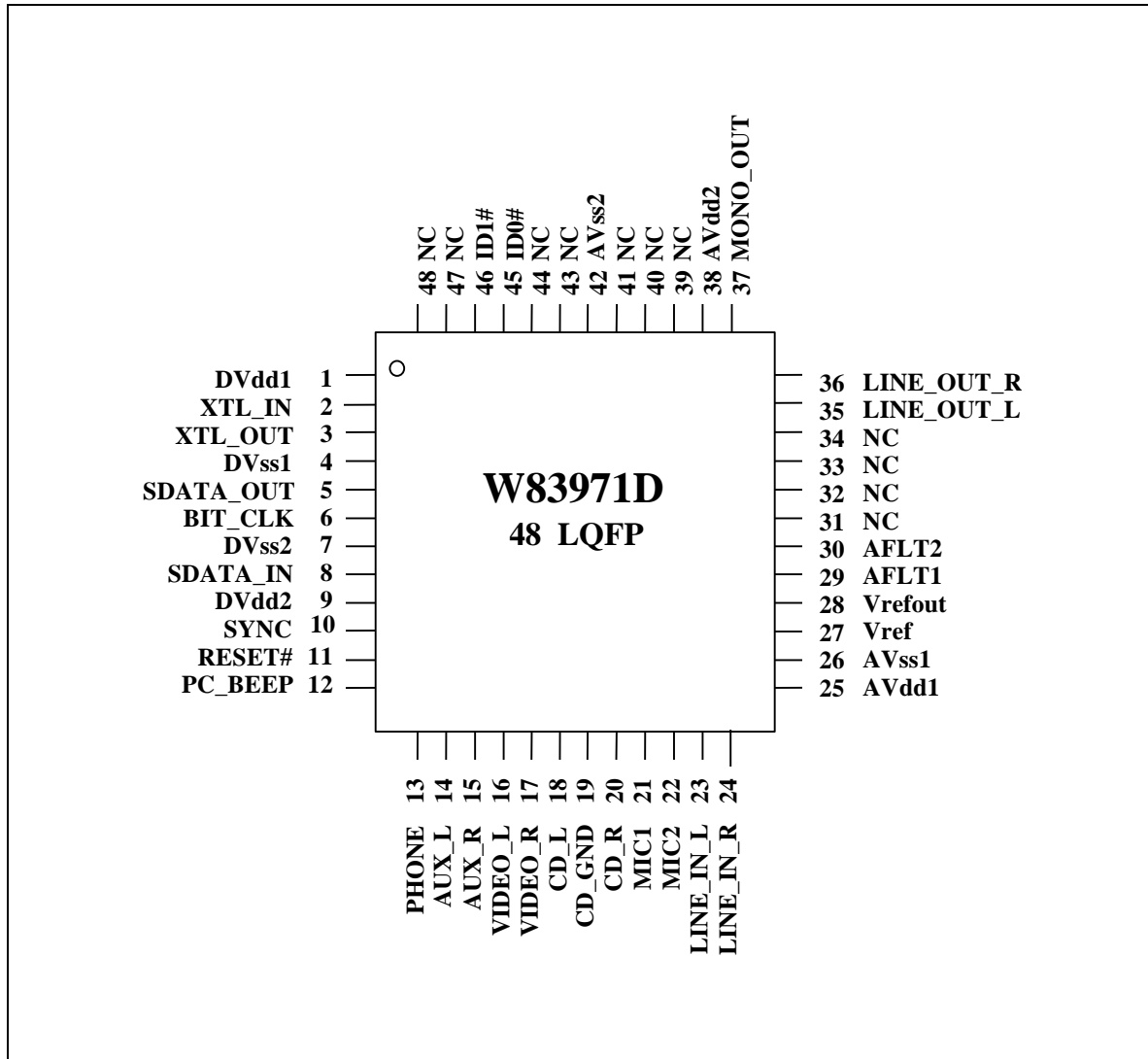

Figure 4.1: W83971D 48-pin Package and Pinout



# Preliminary W83971D



## W83971D 48-LQFP Pin List

PIN#	SIGNAL NAME	PIN#	SIGNAL NAME	PIN#	SIGNAL NAME	PIN#	SIGNAL NAME
1	DVdd1	13	PHONE	25	AVdd1	37	MONO_OUT
2	XTL_IN	14	AUX_L	26	AVss1	38	AVdd2
3	XTL_OUT	15	AUX_R	27	Vref	39	NC
4	DVss1	16	VIDEO_L	28	Vrefout	40	NC
5	SDATA_OUT	17	VIDEO_R	29	AFLT1	41	NC
6	BIT_CLK	18	CD_L	30	AFLT2	42	AVss2
7	DVss2	19	CD_GND	31	NC	43	NC
8	SDATA_IN	20	CD_R	32	NC	44	NC
9	DVdd2	21	MIC1	33	NC	45	ID0#
10	SYNC	22	MIC2	34	NC	46	ID1#
11	RESET#	23	LINE_IN_L	35	LINE_OUT_L	47	NC
12	PC_BEEP	24	LINE_IN_R	36	LINE_OUT_R	48	NC



## 5. PIN DESCRIPTION

### 5.1 Digital I/O

SIGNAL NAME	TYPE	DESCRIPTION
RESET#	I	AC'97 Master Reset
XTL_IN	I	24.576 MHz Crystal
XTL_OUT	O	24.576 MHz Crystal
SYNC	I	48 KHz Fixed Rate Sync Pulse
BIT_CLK	I/O	12.288 MHz Serial Data Clock
SDATA_OUT	I	AC'97 Serial Data Input Stream
SDATA_IN	O	AC'97 Serial Data Output Stream

### 5.2 Analog I/O

SIGNAL NAME	TYPE	DESCRIPTION
PC_BEEP	I	PC Speaker Beep Pass Through
PHONE	I	Telephony Subsystem Speakerphone
MIC1	I	Desktop Microphone
MIC2	I	Second Microphone
LINE_IN_L	I	Line In Left Channel
LINE_IN_R	I	Line In Right Channel
CD_L	I	CD Audio Left Channel
CD_GND	I	CD Audio Analog Ground
CD_R	I	CD Audio Right Channel
VIDEO_L	I	Video Left Channel
VIDEO_R	I	Video Right Channel
AUX_L	I	Auxiliary Left Channel
AUX_R	I	Auxiliary Right Channel
LINE_OUT_L	O	Line Out Left Channel
LINE_OUT_R	O	Line Out Right Channel
MONO_OUT	O	Mono Output



## 5.3 Filter and Reference Pins

SIGNAL NAME	TYPE	DESCRIPTION
Vref	I	Reference Voltage
Vrefout	O	Reference Voltage Output
AFLT1	I	Left Channel Anti-Aliasing Filter Capacitor
AFLT2	I	Right Channel Anti-Aliasing Filter Capacitor

## 5.4 Power Supplies

SIGNAL NAME	TYPE	DESCRIPTION
AVdd1	I	Analog Supply Voltage, 5V
AVdd2	I	Analog Supply Voltage, 5V
AVss1	I	Analog Ground
AVss2	I	Analog Ground
DVdd1	I	Digital Supply Voltage, 5V or 3.3V
DVdd2	I	
DVss1	I	Digital Ground
DVss2	I	Digital Ground

# Preliminary W83971D



## 6. REGISTER DESCRIPTION

### 6.1 Register Map

Reg#	Name	D15	D14	D13	D12	D11	D10	D9	D8	D7	D6	D5	D4	D3	D2	D1	D0	Default
00h	Reset	x	SE4	SE3	SE2	SE1	SE0	ID9	ID8	ID7	ID6	ID5	ID4	ID3	ID2	ID1	ID0	6C00h
02h	Master Volume	Mute	x	ML5	ML4	ML3	ML2	ML1	ML0	x	x	MR5	MR4	MR3	MR2	MR1	MR0	8000h
06h	Master Volume Mono	Mute	x	x	x	x	x	x	x	x	x	MM5	MM4	MM3	MM2	MM1	MM0	8000h
0Ah	PC_BEEP Volume	Mute	x	x	x	x	x	x	x	x	x	x	PV3	PV2	PV1	PV0	x	0000h
0Ch	Phone Volume	Mute	x	x	x	x	x	x	x	x	x	x	GN4	GN3	GN2	GN1	GN0	8008h
0Eh	Mic Volume	Mute	x	x	x	x	x	x	x	x	20db	x	GN4	GN3	GN2	GN1	GN0	8008h
10h	Line in Volume	Mute	x	x	GL4	GL3	GL2	GL1	GL0	x	x	x	GR4	GR3	GR2	GR1	GR0	8808h
12h	CD Volume	Mute	x	x	GL4	GL3	GL2	GL1	GL0	x	x	x	GR4	GR3	GR2	GR1	GR0	8808h
14h	Video Volume	Mute	x	x	GL4	GL3	GL2	GL1	GL0	x	x	x	GR4	GR3	GR2	GR1	GR0	8808h
16h	Aux Volume	Mute	x	x	GL4	GL3	GL2	GL1	GL0	x	x	x	GR4	GR3	GR2	GR1	GR0	8808h
18h	PCM Out Volume	Mute	x	x	GL4	GL3	GL2	GL1	GL0	x	x	x	GR4	GR3	GR2	GR1	GR0	8808h
1Ah	Record Select	x	x	x	x	x	SL2	SL1	SL0	x	x	x	x	x	SR2	SR1	SR0	0000h
1Ch	Record Gain	Mute	x	x	x	GL3	GL2	GL1	GL0	x	x	x	x	GR3	GR2	GR1	GR0	8000h
20h	General Purpose	x	x	3D	x	x	x	MIX	MS	LPBK	x	x	x	x	x	x	x	0000h
22h	3D Control	x	x	x	x	x	x	x	x	x	x	x	x	DP3	DP2	DP1	DP0	0800h
26h	Pwrdown Control/Status	x	x	PR5	PR4	PR3	PR2	PR1	PR0	x	x	x	x	REF	ANL	DAC	ADC	00Fh
28h	Reserved	x	x	x	x	x	x	x	x	x	x	x	x	x	x	x	x	x
..	..	..	..	..	..	..	..	..	..	..	..	..	..	..	..	..	..	..
..	..	..	..	..	..	..	..	..	..	..	..	..	..	..	..	..	..	..
7Ah	Vendor Reserved	x	x	x	x	x	x	x	x	x	x	x	x	x	x	x	x	x
7Ch	Vendor ID1	F7	F6	F5	F4	F3	F2	F1	F0	S7	S6	S5	S4	S3	S2	S1	S0	5745h
7Eh	Vendor ID2	T7	T6	T5	T4	T3	T2	T1	T0	REV7	REV6	REV5	REV4	REV3	REV2	REV1	REV0	4301h

Table 1: Mixer Register



## 6.2 Reset Register (Index 00h)

Reg#	D15	D14	D13	D12	D11	D10	D9	D8	D7	D6	D5	D4	D3	D2	D1	D0	Default
00h	0	1	1	0	1	1		0	0	0	0	0	0	0	0	0	0000h

The Reset register is used to configure the hardware to a known state or is used to read the status of the current hardware configuration. Writing data to this register will set all the mixer registers to their default values. Reading data from this register will return the ID code for the device.

Register Map: Register Write: sets all mixer registers to default value  
 Register Read: returns ID code for device  
 D10~D13: 3D stereo enhancement ID

## 6.3 Stereo Output Control Register (Index 02h)

Reg#	D15	D14	D13	D12	D11	D10	D9	D8	D7	D6	D5	D4	D3	D2	D1	D0	Default
02h	Mute		ML5	ML4	ML3	ML2	ML1	ML0			MR5	MR4	MR3	MR2	MR1	MR0	8000h

### 6.3.1 Mute Stereo Output Mute Control

"1" : Mute enabled

"0" : Mute disabled

### 6.3.2 ML[5:0] Master Output (Left Channel) Volume Control

These six bits select the level of attenuation applied to the Left channel of the Stereo Output signal. The level of attenuation is programmable from 0dB to -94.5dB in 1.5dB increments, providing a total of 64 programmable levels.

### 6.3.3 MR[5:0] Master Output (Right Channel) Volume Control

These six bits select the level of attenuation applied to the Right channel of the Stereo Output signal. The level of attenuation is programmable from 0dB to -94.5dB in 1.5dB increments, providing a total of 64 programmable levels.



## 6.3.4 Output Volume Control Map

	MR0	MR1	MR2	MR3	MR4	MR5	Level(dB)
0	0	0	0	0	0	0	0.0
1	0	0	0	0	0	1	-1.5
2	0	0	0	0	1	0	-3.0
3	0	0	0	0	1	1	-4.5
4	0	0	0	1	0	0	-6.0
5	0	0	0	1	0	1	-7.5
..	..	..	..	..	..	..	..
..	..	..	..	..	..	..	..
60	1	1	1	1	0	0	-90.0
61	1	1	1	1	0	1	-91.5
62	1	1	1	1	1	0	-93.0
63	1	1	1	1	1	1	-94.5



## 6.4 Mono Output Control Register (Index 06h)

Reg#	D15	D14	D13	D12	D11	D10	D9	D8	D7	D6	D5	D4	D3	D2	D1	D0	Default
06h	Mute										MM5	MM4	MM3	MM2	MM1	MM0	8000h

### 6.4.1 Mute Mono Output Mute Control

"1" : Mute enabled

"0" : Mute disabled

### 6.4.2 MM[5:0] Mono Output Volume Control

These six bits select the level of attenuation applied to the Mono Output signal. The level of attenuation is programmable from 0dB to -94.5dB in 1.5dB increments, providing a total of 64 programmable levels.

Please refer to **Stereo and Mono Output Attenuation**.

### 6.4.3 Stereo and Mono Output Attenuation

	MM0	MM1	MM2	MM3	MM4	MM5	LEVEL(DB)
0	0	0	0	0	0	0	0.0
1	0	0	0	0	0	1	-1.5
2	0	0	0	0	1	0	-3.0
3	0	0	0	0	1	1	-4.5
4	0	0	0	1	0	0	-6.0
5	0	0	0	1	0	1	-7.5
..	..	..	..	..	..	..	..
..	..	..	..	..	..	..	..
60	1	1	1	1	0	0	-90.0
61	1	1	1	1	0	1	-91.5
62	1	1	1	1	1	0	-93.0
63	1	1	1	1	1	1	-94.5



## 6.5 PC\_BEEP Input Volume Control Register (Index 0Ah)

Reg#	D15	D14	D13	D12	D11	D10	D9	D8	D7	D6	D5	D4	D3	D2	D1	D0	Default
0Ah												PV3	PV2	PV1	PV0		0000h

### 6.5.1 Mute PC Beep Input Mute Control

"1" : Mute enabled

"0" : Mute disabled

### 6.5.2 PV[3:0] PC Beep Input Volume Control

These four bits select the level of attenuation applied to the PC beep input signal. The level of attenuation is programmable from 0dB to -45dB in 3dB increments, providing a total of 16 programmable levels. The beep gain is set at 0dB when PV[3:0] = 0h.

## 6.6 Phone Input Volume Control Register (Index 0Ch)

Reg#	D15	D14	D13	D12	D11	D10	D9	D8	D7	D6	D5	D4	D3	D2	D1	D0	Default
0Ch	Mute											GN4	GN3	GN2	GN1	GN0	8008h

### 6.6.1 Mute Phone Input Mute Control

"1" : Mute enabled

"0" : Mute disabled

### 6.6.2 GN[4:0] PC Phone Input Volume Control

These five bits select the gain applied to the Phone Input signal. The gain is programmable from -34.5dB to 12dB in 1.5dB increments, providing a total of 32 programmable levels.

Please refer to **Programmable Input and Output Gain Levels** .





## 6.6.3 Programmable Input and Output Gain Levels

	G4	G3	G2	G1	G0	LEVEL(DB)
0	0	0	0	0	0	12.0
1	0	0	0	0	1	10.5
2	0	0	0	1	0	9.0
3	0	0	0	1	1	7.5
4	0	0	1	0	0	6.0
5	0	0	1	0	1	4.5
6	0	0	1	1	0	3.0
7	0	0	1	1	1	1.5
8	0	1	0	0	0	0.0
9	0	1	0	0	1	-1.5
10	0	1	0	1	0	-3.0
11	0	1	0	1	1	-4.5
12	0	1	1	0	0	-6.0
13	0	1	1	0	1	-7.5
14	0	1	1	1	0	-9.0
15	0	1	1	1	1	-10.5
16	1	0	0	0	0	-12.0
17	1	0	0	0	1	-13.5
18	1	0	0	1	0	-15.0
19	1	0	0	1	1	-16.5
20	1	0	1	0	0	-18.0
21	1	0	1	0	1	-19.5
22	1	0	1	1	0	-21.0
23	1	0	1	1	1	-22.5
24	1	1	0	0	0	-24.0
25	1	1	0	0	1	-25.5
26	1	1	0	1	0	-27.0
27	1	1	0	1	1	-28.5
28	1	1	1	0	0	-30.0
29	1	1	1	0	1	-31.5
30	1	1	1	1	0	-33.0
31	1	1	1	1	1	-34.5



## 6.7 Mic Input Volume Control Register (Index 0Eh)

Reg#	D15	D14	D13	D12	D11	D10	D9	D8	D7	D6	D5	D4	D3	D2	D1	D0	Default
0Eh	Mute									20dB		GN4	GN3	GN2	GN1	GN0	8008h

### 6.7.1 Mute Mic Input Mute Control

"1" : Mute enabled

"0" : Mute disabled

### 6.7.2 20dB Mic Boost Control

"1" : Fixed 20dB gain enabled

"0" : Fixed 20dB gain disabled

### 6.7.3 GN[4:0] Mic Input Volume Control

These five bits select the gain applied to the Mic Input signal. The gain is programmable from -34.5dB to 12dB in 1.5dB increments, providing a total of 32 programmable levels.

Please refer to **Programmable Input and Output Gain Levels** .

## 6.8 Line Input Control Register (Index 10h)

Reg#	D15	D14	D13	D12	D11	D10	D9	D8	D7	D6	D5	D4	D3	D2	D1	D0	Default
10h	Mute			GL4	GL3	GL2	GL1	GL0				GR4	GR3	GR2	GR1	GR0	8808h

### 6.8.1 Mute Line Input Mute Control

"1" : Mute enabled

"0" : Mute disabled

### 6.8.2 GL[4:0] Left Channel Gain Control

These five bits select the gain applied to the LEFT channel of the Line Input signal. The gain is programmable from -34.5dB to 12dB in 1.5dB increments, providing a total of 32 programmable levels.

Please refer to **Programmable Input and Output Gain Levels** .



### 6.8.3 GR[4:0] Right Channel Gain Control

These five bits select the gain applied to the RIGHT channel of the Line Input signal.

The gain is programmable from -34.5dB to 12dB in 1.5dB increments, providing a total of 32 programmable levels.

Please refer to **Programmable Input and Output Gain Levels**.

### 6.9 CD Input Control Register (Index 12h)

Reg#	D15	D14	D13	D12	D11	D10	D9	D8	D7	D6	D5	D4	D3	D2	D1	D0	Default
12h	Mute			GL4	GL3	GL2	GL1	GL0				GR4	GR3	GR2	GR1	GR0	8808h

#### 6.9.1 Mute Line Input Mute Control

"1" : Mute enabled

"0" : Mute disabled

#### 6.9.2 GL[4:0] Left Channel Gain Control

These five bits select the gain applied to the LEFT channel of the Line Input signal. The gain is programmable from -34.5dB to 12dB in 1.5dB increments, providing a total of 32 programmable levels.

Please refer to **Programmable Input and Output Gain Levels**.

#### 6.9.3 GR[4:0] Right Channel Gain Control

These five bits select the gain applied to the RIGHT channel of the Line Input signal. The gain is programmable from -34.5dB to 12dB in 1.5dB increments, providing a total of 32 programmable levels.

Please refer to **Table 3: Programmable Input and Output Gain Levels**.

### 6.10 Video Input Control Register (Index 14h)

Reg#	D15	D14	D13	D12	D11	D10	D9	D8	D7	D6	D5	D4	D3	D2	D1	D0	Default
14h	Mute			GL4	GL3	GL2	GL1	GL0				GR4	GR3	GR2	GR1	GR0	8808h

#### 6.10.1 Mute Line Input Mute Control

"1" : Mute enabled

"0" : Mute disabled



## 6.10.2 6.10.2 GL[4:0] Left Channel Gain Control

These five bits select the gain applied to the LEFT channel of the Line Input signal. The gain is programmable from -34.5dB to 12dB in 1.5dB increments, providing a total of 32 programmable levels.

Please refer to **Programmable Input and Output Gain Levels** .

## 6.10.3 GR[4:0] Right Channel Gain Control

These five bits select the gain applied to the RIGHT channel of the Line Input signal. The gain is programmable from -34.5dB to 12dB in 1.5dB increments, providing a total of 32 programmable levels.

Please refer to **Programmable Input and Output Gain Levels** .

## 6.11 Auxiliary Input Control Register (Index 16h)

Reg#	D15	D14	D13	D12	D11	D10	D9	D8	D7	D6	D5	D4	D3	D2	D1	D0	Default
16h	Mute			GL4	GL3	GL2	GL1	GL0				GR4	GR3	GR2	GR1	GR0	8808h

### 6.11.1 Mute Line Input Mute Control

"1" : Mute enabled

"0" : Mute disabled

### 6.11.2 GL[4:0] Left Channel Gain Control

These five bits select the gain applied to the LEFT channel of the Line Input signal. The gain is programmable from -34.5dB to 12dB in 1.5dB increments, providing a total of 32 programmable levels.

Please refer to **Programmable Input and Output Gain Levels** .

### 6.11.3 GR[4:0] Right Channel Gain Control

These five bits select the gain applied to the RIGHT channel of the Line Input signal. The gain is programmable from -34.5dB to 12dB in 1.5dB increments, providing a total of 32 programmable levels.

Please refer to **Programmable Input and Output Gain Levels** .

# Preliminary W83971D



## 6.12 PCM Output Control Register (Index 18h)

Reg#	D15	D14	D13	D12	D11	D10	D9	D8	D7	D6	D5	D4	D3	D2	D1	D0	Default
18h	Mute			GL4	GL3	GL2	GL1	GL0				GR4	GR3	GR2	GR1	GR0	8808h

### 6.12.1 Mute Line Input Mute Control

"1" : Mute enabled

"0" : Mute disabled

### 6.12.2 GL[4:0] Left Channel Gain Control

These five bits select the gain applied to the LEFT channel of the Line Input signal. The gain is programmable from -34.5dB to 12dB in 1.5dB increments, providing a total of 32 programmable levels.

Please refer to **Programmable Input and Output Gain Levels** .

### 6.12.3 GR[4:0] Right Channel Gain Control

These five bits select the gain applied to the RIGHT channel of the Line Input signal. The gain is programmable from -34.5dB to 12dB in 1.5dB increments, providing a total of 32 programmable levels.

Please refer to **Programmable Input and Output Gain Levels** .

## 6.13 Record Select Register (Index 1Ah)

Reg#	D15	D14	D13	D12	D11	D10	D9	D8	D7	D6	D5	D4	D3	D2	D1	D0	Default
1Ah						SL2	SL1	SL0						SR2	SR1	SR0	0000h

### 6.13.1 Record Source Select(Left Channel)

SL<2:0>	Left Record Source
<000>	Mic
<001>	CD_L
<010>	Video In_L
<011>	Aux In_L
<100>	Line In_L
<101>	Stereo Mix_L
<110>	Mono Mix
<111>	Phone

### Record Source Select(Right Channel)

SR<2:0>	Right Record Source
<000>	Mic
<001>	CD_R
<010>	Video In_R
<011>	Aux In_R
<100>	Line In_R
<101>	Stereo Mix_R
<110>	Mono Mix
<111>	Phone



## 6.14 Record Gain Control Register (Index 1Ch)

Reg#	D15	D14	D13	D12	D11	D10	D9	D8	D7	D6	D5	D4	D3	D2	D1	D0	Default
1Ch	Mute				GL3	GL2	GL1	GL0					GR3	GR2	GR1	GR0	8000h

### 6.14.1 Mute Record Mute Control

"1" : Mute enabled

"0" : Mute disabled

### 6.14.2 GL[3:0] Record Gain Control (Left Channel)

These four bits select the gain applied to the LEFT channel recording source. The gain is programmable from 0dB to 22.5dB in 1.5dB increments, providing a total of 16 programmable levels.

The gain is set at 0dB when GL[3:0] = 0h.

### 6.14.3 GR[3:0] Record Gain Control (Right Channel)

These four bits select the gain applied to the RIGHT channel recording source. The gain is programmable from 0dB to 22.5dB in 1.5dB increments, providing a total of 16 programmable levels.

## 6.15 General Purpose Register (Index 20h)

Reg#	D15	D14	D13	D12	D11	D10	D9	D8	D7	D6	D5	D4	D3	D2	D1	D0	Default
20h			3D				MIX	MS	LPBK								0000h

### 6.15.1 3D Stereo Enhancement

"1" : Enabled

"0" : Disabled

### 6.15.2 MIX Mono Output Mode

"1" : Mic Output

"0" : Mono mix output

### 6.15.3 MS Microphone Select

"1" : Microphone 2

"0" : Microphone 1

### 6.15.4 LPBK Loopback Mode

"1" : DAC/ADC Loopback enabled

"0" : DAC/ADC Loopback disabled

# Preliminary W83971D



## 6.16 3D Control Register (Index 22h)

Reg#	D15	D14	D13	D12	D11	D10	D9	D8	D7	D6	D5	D4	D3	D2	D1	D0	Default
22h													DP3	DP2	DP1	DP0	0000h

This Register is used to control the depth of the 3D stereo enhancement function built into of the AC'97 controller.

### 6.16.1 Depth of 3D Control Level

DP3 ... DP0	Depth
0	0%
1	6.67%
...	...
14	93.33%
15	100%

## 6.17 Power Down and Status Register (Index 26h)

Reg#	D15	D14	D13	D12	D11	D10	D9	D8	D7	D6	D5	D4	D3	D2	D1	D0	Default
26h			PR5	PR4	PR3	PR2	PR1	PR0					REF	ANL	DAC	ADC	0000h

### 6.17.1 PR[5:0] Power Down Mode Bits

These read/write bits are used to control the power down states of the W83971D. Each power down function bit is enabled by setting the respective bit high. The power down modes controlled by each bit is described in the table below:

### 6.17.2 Status (READ Only) bits

These bits are used to monitor the readiness of some sections of the W83971D. Reading a "1" from any of these bits would be an indication of a "ready" state.

D<3:0>	Status Read Only Bits
REF	Vref at Nominal Levels
ANL	Mixers, Mux & Volume Controls Ready
DAC	DAC Ready to Accept Data
ADC	ADC Ready to Transmit Data

PR<5:0>	Power Down Mode Bits
PR0	ADC & Mux Power down
PR1	DAC Power down
PR2	Mixer (Vref on) Power down
PR3	Mixer (Vref off) Power down
PR4	AC-Link (BIT_CLK off) Power down
PR5	Internal Clock Disable



## 6.18 Vendor Identification Registers (Index 7Ch, 7Eh)

Reg#	D15	D14	D13	D12	D11	D10	D9	D8	D7	D6	D5	D4	D3	D2	D1	D0	Default
7Ch	0	1	0	1	0	1	1	1	0	1	0	0	0	1	0	1	5745h
7Eh	0	1	0	0	0	0	1	1	0	0	0	0	0	0	0	1	4301h

The upper and lower byte of this register (index 7Ch), in conjunction with the upper byte of index register 7Eh, make up the vendor identification code for the W83971D. The Vendor ID Code (in ASCII format) is equal to WEC (Winbond Elec. Inc.), where:

**F[7:0] Upper Byte (Index 7Ch) D[15:8] = W**

**S[7:0] Lower Byte (Index 7Ch) D[7:0] = E**

**T[15:8] Upper Byte (Index 7Eh) D[15:8] = C**

The upper byte of this register is used in conjunction with index register 7Ch to make up the Vendor ID code for the W83971D. The lower byte identifies the revision code of the W83971D.

**T[15:8] See description in Vendor Identification Register.**

**REV[7:0] Revision ID "01" as Revision Number.**





## 7. MULTIPLE CODEC EXTENSION

One primary and a maximum of three secondary codecs may be supported as an option.

### 7.1 Multiple Codec Mode Select

ID0	ID1	Codec Mode
NC	NC	Primary Codec
pull down	NC	Secondary Codec 1
NC	pull down	Secondary Codec 2
pull down	pull down	Secondary Codec 3

Note: Digital Controller supports four DATA\_IN pins to support one primary and three secondary codecs. BIT\_CLK is an output for the primary codec and an input pin for the controller and secondary codecs.



### 7.2 Multiple Codec Example

One primary codec and three secondary codecs, with ID0 and ID1 defining which codec is primary and the order of the secondary codecs. Note that the ID0 and ID1 are internally pulled up; therefore, when left floating they configure Codec as Primary. Note: 1 = pull up. 0 = pull down.

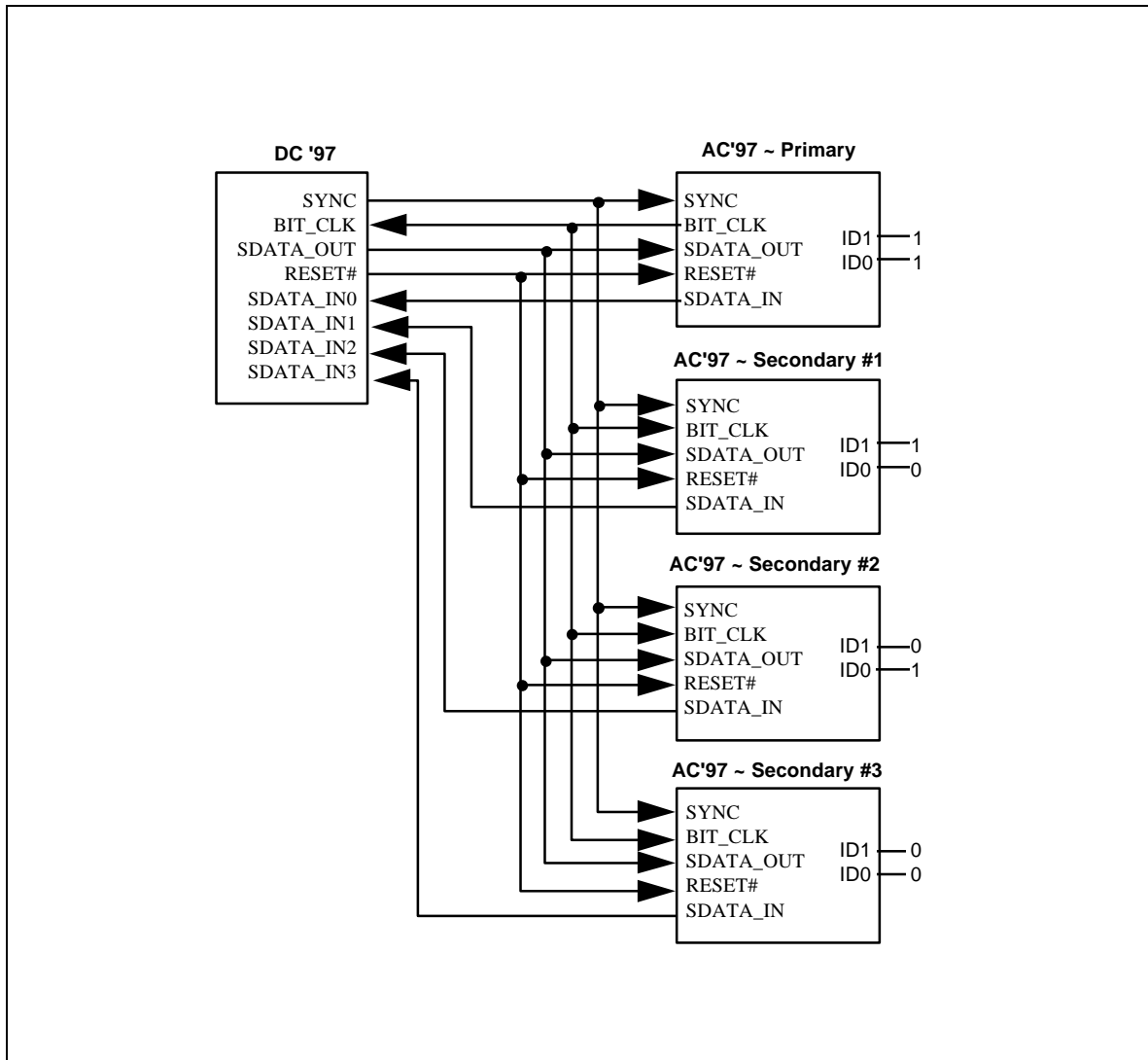

Figure 7.1: Multiple Codec Example



## 8. ELECTRICAL SPECIFICATIONS

### 8.1 DC Characteristics

T<sub>A</sub> = 25°C, DV<sub>DD</sub> = 5.0V or 3.3V +/- 5%; AV<sub>SS</sub> = DV<sub>SS</sub> = 0V; 50 pF load

PARAMETERS	SYMBOL	MIN.	TYP.	MAX.	UNITS
Input Voltage Range	V <sub>IN</sub>	-0.3		V <sub>DD</sub> + 0.3	V
Input Voltage (low)	V <sub>IL</sub>			0.3 x V <sub>DD</sub>	V
Input Voltage (high)	V <sub>IH</sub>	0.4 x V <sub>DD</sub>			V
Output Voltage (low)	V <sub>OL</sub>			0.2 x V <sub>DD</sub>	V
Output Voltage (high)	V <sub>OH</sub>	0.5 x V <sub>DD</sub>			V
Input Leakage Current (AC-Link)		-10		10	μA
Output Leakage Current (AC-Link and Hi-Z)		-10		10	μA
Output Buffer Drive Current			5		mA

### 8.2 AC Timing Characteristics

#### Timing Diagrams

T<sub>A</sub> = 25°C, DV<sub>DD</sub> = 5.0V or 3.3V +/- 5%; AV<sub>SS</sub> = DV<sub>SS</sub> = 0V; 50 pF load

Cold Reset/Warm Reset

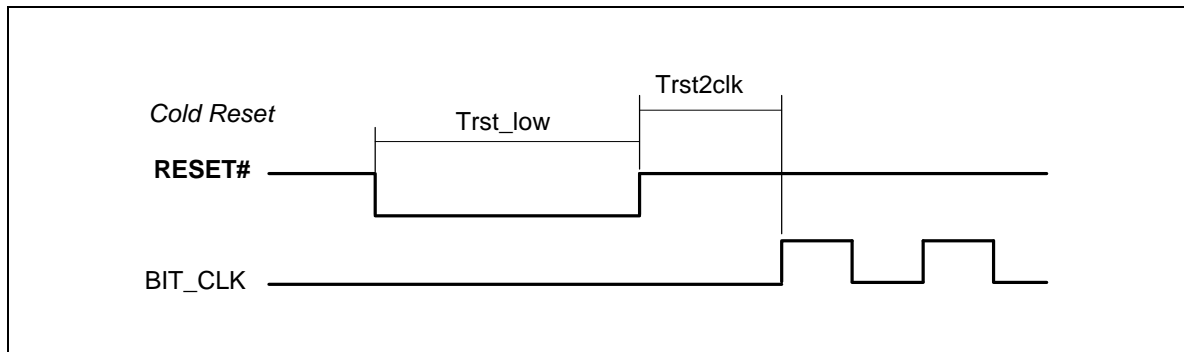

PARAMETERS	SYMBOL	MIN.	TYP.	MAX.	UNITS
RESET# active low pulse width	Trstlow	1			μS
RESET# inactive to BIT_CLK startup delay	Trst2clk	162.8			μS

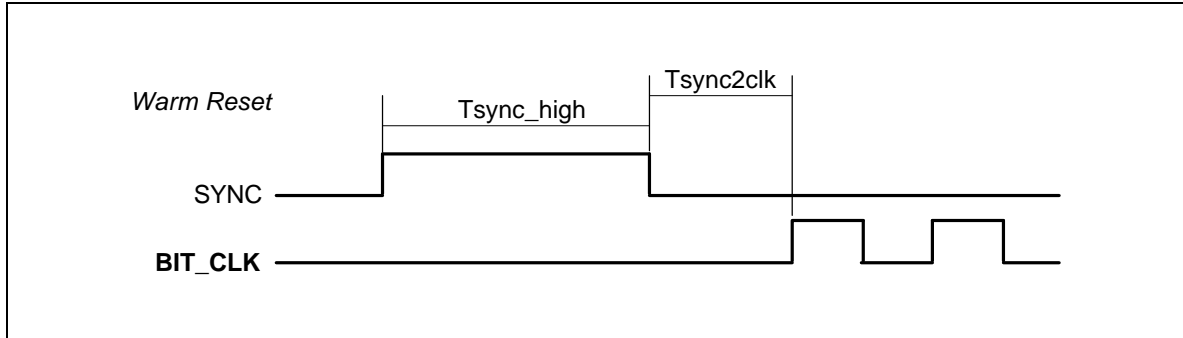

PARAMETERS	SYMBOL	MIN.	TYP.	MAX.	UNITS
SYNC active high pulse width	$T_{sync\_high}$		1.3		$\mu\text{S}$
SYNC inactive to BIT_CLK startup delay	$T_{sync2clk}$	162.8			nS

### 8.3 BIT\_CLK / SYNC

Duty Cycle: 40/60 (worst case)

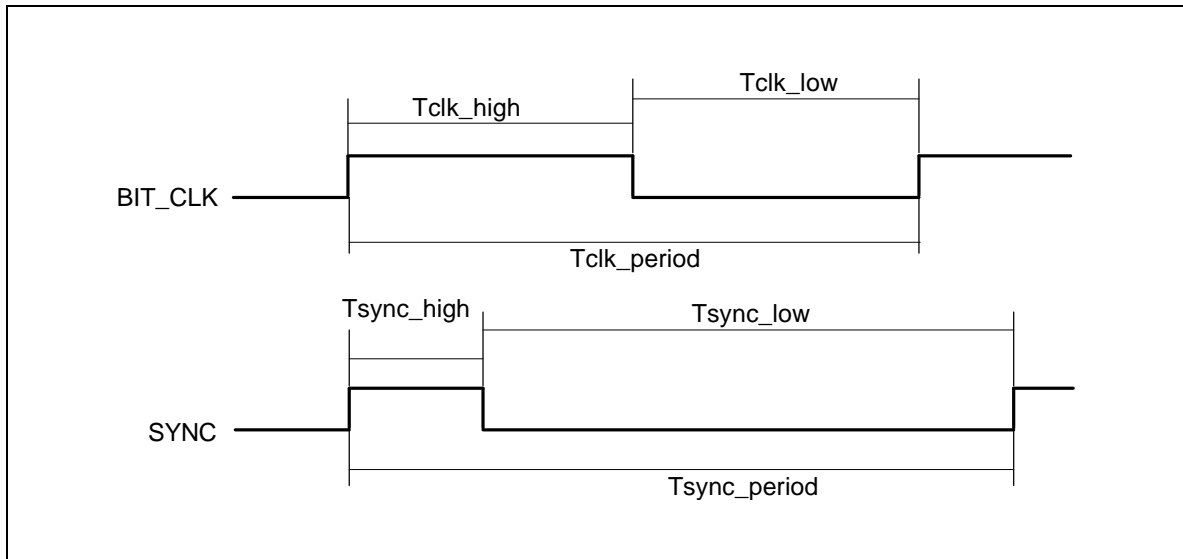

# Preliminary W83971D



PARAMETERS	SYMBOL	MIN.	TYP.	MAX.	UNITS
BIT_CLK frequency			12.288		MHz
BIT_CLK period	Tclk_period		81.4		nS
BIT_CLK output jitter				750	pS
BIT_CLK pulse width (high)	Tclk_high	32.56	40.7	48.84	nS
BIT_CLK pulse width (low)	Tclk_low	32.56	40.7	48.84	nS
SYNC frequency			48		KHz
SYNC period	Tsync_period		20.8		μS
SYNC pulse width (high)	Tsync_high		1.3		μS
SYNC pulse width (low)	Tsync_low		19.5		μS

## 8.4 Setup and Hold

Load Capacitance: 50 pF

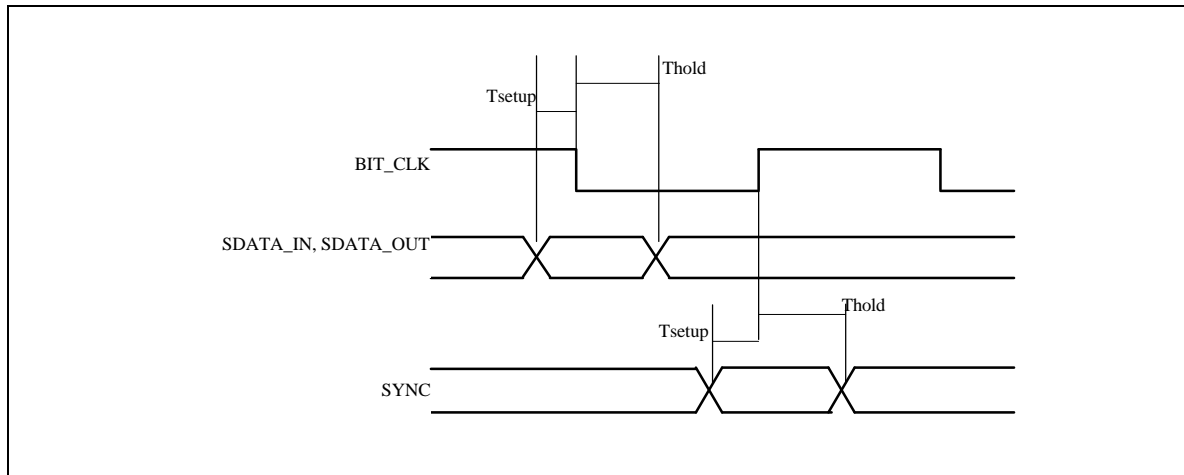

PARAMETERS	SYMBOL	MIN.	TYP.	MAX.	UNIT S
SDATA_OUT setup to falling edge of BIT_CLK	Tsetup	15			nS
SDATA_OUT hold from falling edge of BIT_CLK	Thold	5			nS
SYNC setup to rising edge of BIT_CLK	Tsetup	15			nS
SYNC hold from rising edge of BIT_CLK	Thold	5			nS

Note: SDATA\_IN setup and hold calculations determined by AC'97 Controller propagation delay

Publication Release Date: July 1999

Revision A1



8.5 Rise and Fall

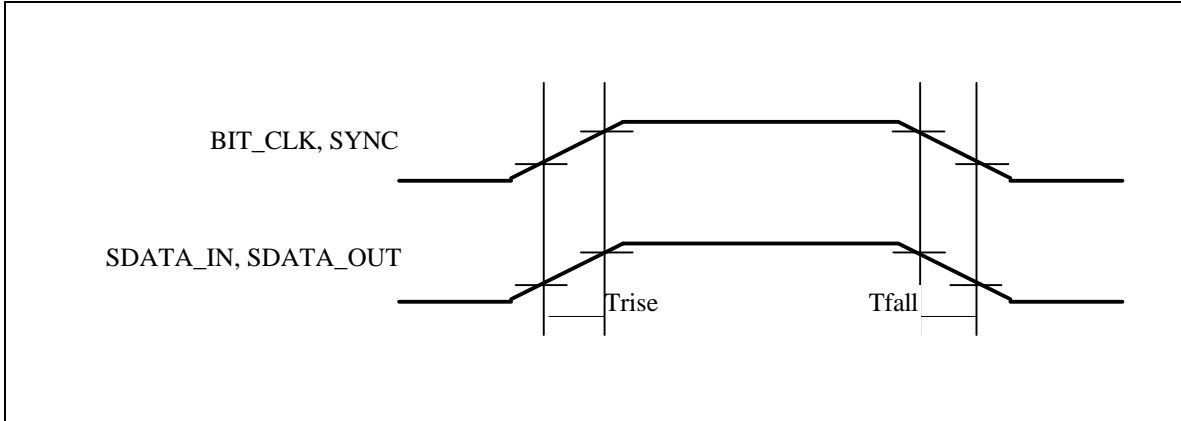

PARAMETERS	SYMBOL	MIN.	TYP.	MAX.	UNITS
BIT_CLK rise time	Trise	2		6	nS
BIT_CLK fall time	Tfall	2		6	nS
SYNC rise time	Trise	2		6	nS
SYNC fall time	Tfall	2		6	nS
SDATA_IN rise time	Trise	2		6	nS
SDATA_IN fall time	Tfall	2		6	nS
SDATA_OUT rise time	Trise	2		6	nS
SDATA_OUT fall time	Tfall	2		6	nS



8.6 AC\_Link Low Power Mode

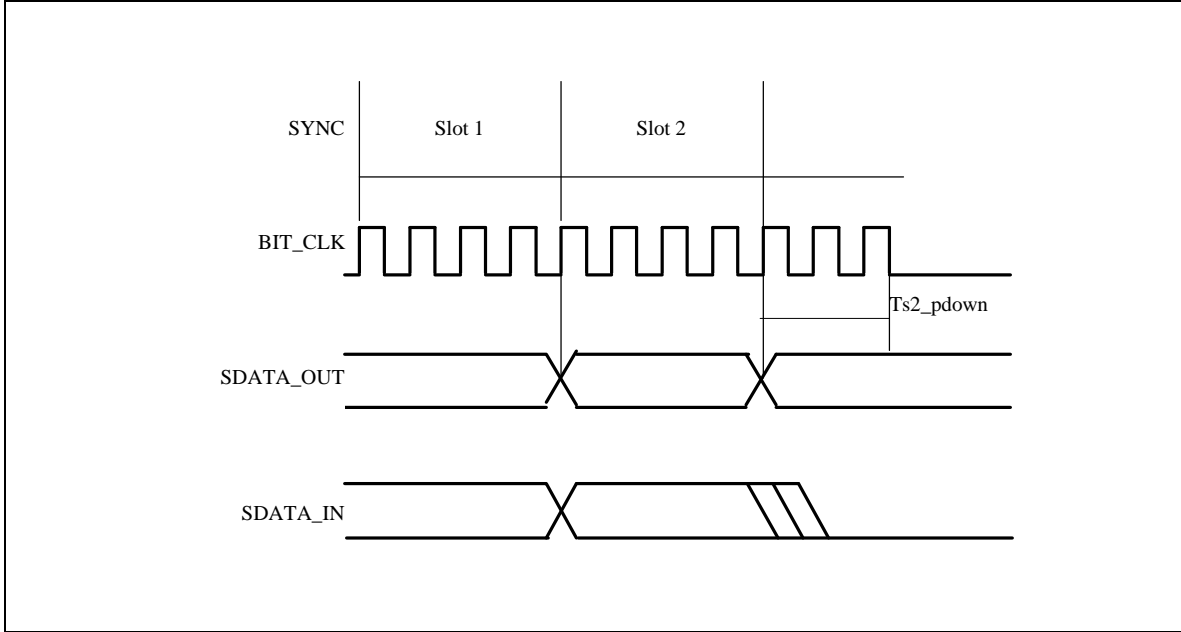

PARAMETERS	SYMBOL	MIN.	TYP.	MAX.	UNITS
End of Slot 2 to BIT_CLK/SDATA_IN low	Ts2_pdown			1	μS

Note: BIT\_CLK not to scale



8.7 ATE/ Vendor Test Mode

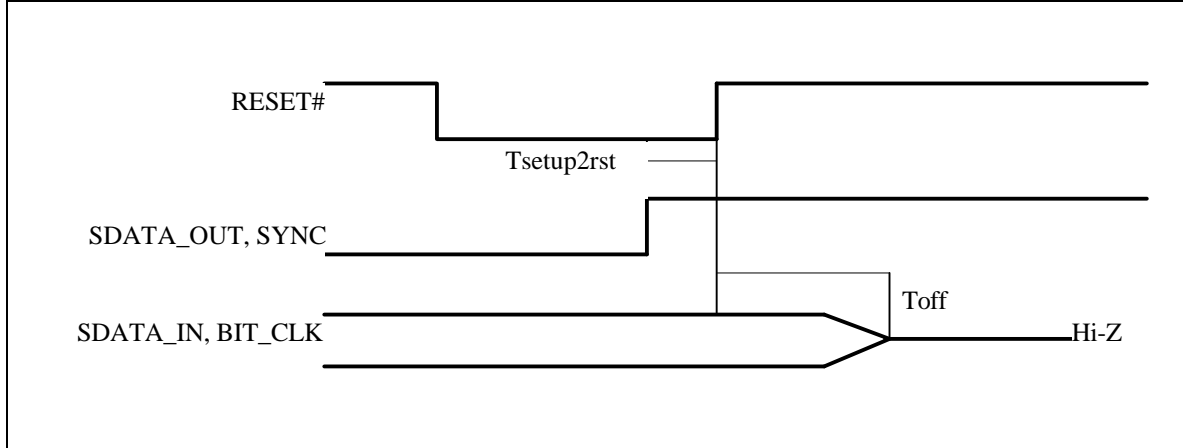

PARAMETERS	SYMBOL	MIN.	TYP.	MAX.	UNITS
SDATA_OUT/SYNC setup to RESET# rising edge	Tsetup2rst	15			nS
RESET# rising edge to Hi-Z state	Toff			25	nS





## 9. PERFORMANCE SPECIFICATIONS

### 9.1 Analog Characteristics

T<sub>A</sub> = 25°C, AV<sub>DD</sub> = DV<sub>DD</sub> = 5.0V +/- 5%; AV<sub>SS</sub> = DV<sub>SS</sub> = 0V; 10 KΩ/50 pF load

F<sub>s</sub> = 48 KHz, 0 dB = 1 Vrms; BW: 20 Hz ~ 20 KHz, 0 dB attenuation

PARAMETERS	SYMBOL	MIN.	TYP.	MAX.	UNITS
Full Scale Input Voltage:					
Line Inputs			1.0		Vrms
Mic Inputs (20dB = 0)			1.0		Vrms
Mic Inputs (20dB = 1)			0.1		Vrms
Full Scale Output Voltage:					
Line Outputs			1.0		Vrms
Mono Output			1.0		Vrms
Analog S/N:					
CD to LINE_OUT		90			dB
Other to LINE_OUT			85		dB
Analog Frequency Response:		20		20,000	Hz
Digital S/N:					
D/A		85	90		dB
A/D		75	80		dB
Total Harmonic Distortion:					
Line Outputs			0.007	0.02	%
D/A & A/D Frequency Response:					
D/A		20		19,200	Hz
A/D		20		19,200	Hz
Transition Band:					
D/A		19,200		28,800	Hz
A/D		19,200		28,800	Hz
Stop Band:					
D/A		28,800		infinite	Hz
A/D		28,800		infinite	Hz
Stop Band Rejection:					
D/A		-74			dB
A/D		-74			dB
Out-of-Band Rejection:			-40		dB
Group Delay:				1	mS
Power Supply Rejection Ratio:			-40		dB

# Preliminary W83971D



PARAMETERS	SYMBOL	MIN.	TYP.	MAX.	UNITS
(1kHz)					
Input Channel Crosstalk:				-70	dB
Spurious Tone Reduction:			-100		dB
Attenuation, Gain Step Size			1.5		dB
Input Impedance:		10	50		K ohm
Input Capacitance:			15		pF
Vrefout			1.5		V

Notes:  $V_{IL} = 0.8V$ ,  $V_{IH} = 2.4V$

Analog Frequency Response has  $\pm 1$ dB limits

SNR of rms output level with 1 KHz full-scale input to rms output level with all zeros into digital input

Measured "A wtd" over a 20 Hz ~ 20 KHz bandwidth (AES17-1991 Idle Channel Noise or EIAJ CP-307 SNR)

THD: 0dB gain, 20 KHz BW,  $F_s = 48$  KHz

A/D & D/A Frequency Response has  $\pm 0.25$  dB limits

Stop Band Rejection determines filter requirements

Out-of-Band rejection determines audible noise

Integrated Out-of-Band noise generated by DAC during normal PCM audio playback over: BW = 28.8 KHz ~ 100 KHz, with respect to 1 Vrms DAC output

# Preliminary W83971D



## 9.2 Miscellaneous Analog Performance Characteristics:

T<sub>A</sub> = 25°C, AV<sub>DD</sub> = DV<sub>DD</sub> = 5.0V +/- 5%; AV<sub>SS</sub> = DV<sub>SS</sub> = 0V; 10 KΩ/50 pF load

F<sub>s</sub> = 48 KHz, 0 dB = 1 Vrms; BW: 20 Hz ~ 20 KHz, 0 dB attenuation

PARAMETERS	SYMBOL	MIN	TYP	MAX	UNITS
Mixer Gain Range Span:					
LINE_IN, AUX, VIDEO, MIC1, MIC2, PHONE			46.5		dB
PC_BEEP			45		dB
LINE_OUT, MONO_OUT			94.5		dB
Mixer Step Size:					
All Volume Controls Except PC_BEEP			1.5		dB
PC_BEEP			3.0		dB
Mixer Mute Level:			110		dB
Mixer Gain:					
Interchannel Gain Mismatch		-0.5		0.5	dB
Gain Drift			100		ppm/°C
A/D and Analog Inputs: (R <sub>s</sub> = 50 ohms)					
Resolution				16	bits
Gain Error			±2	±5	%
Offset Error			10		mV
Input Impedance			50		k ohm
D/A and Analog Outputs:					
Resolution				16	bits
Interchannel Isolation			85		dB
Interchannel Gain Mismatch			0.1	0.2	dB
Gain Error				±5	%
Gain Drift			60		ppm/°C

Note: Gain Error and Offset Error expressed in terms of ± values



## 9.3 Power Consumption:

T<sub>A</sub> = 25°C, AV<sub>DD</sub> = DV<sub>DD</sub> = 5.0V +/- 5%; AV<sub>SS</sub> = DV<sub>SS</sub> = 0V; 50 pF load

PARAMETERS	SYMBOL	MIN.	TYP.	MAX.	UNITS
Digital Supply Current:					
Power Up	lvdd		70		mA
Power Down	lvdd		0.1		mA
Analog Supply Current:					
Power Up	lavd		28		mA
Power Down	lavd		0.1		mA

## 10. POWER MANAGEMENT

Power Management is capable of shutting down portions of the Codec with Control Bits

PR<5:0>	POWER DOWN MODE BITS
PR0	PCM_IN ADC & Input MUX Powerdown
PR1	PCM_OUT DAC Powerdown
PR2	Analog Mixer Powerdown (Vref on)
PR3	Analog Mixer Powerdown (Vref off)
PR4	Digital Interface (AC-Link) Powerdown (BIT_CLK off)
PR5	Internal Clock Disable

Note: Registers maintain values in sleep mode (PR4 write) and wake up with a warm reset (register values) or a cold reset (default values). Power Down and Status Register (Index 26) read action verifies stability before powerdown write action occurs.

## 10.1 Power Down / Power Up

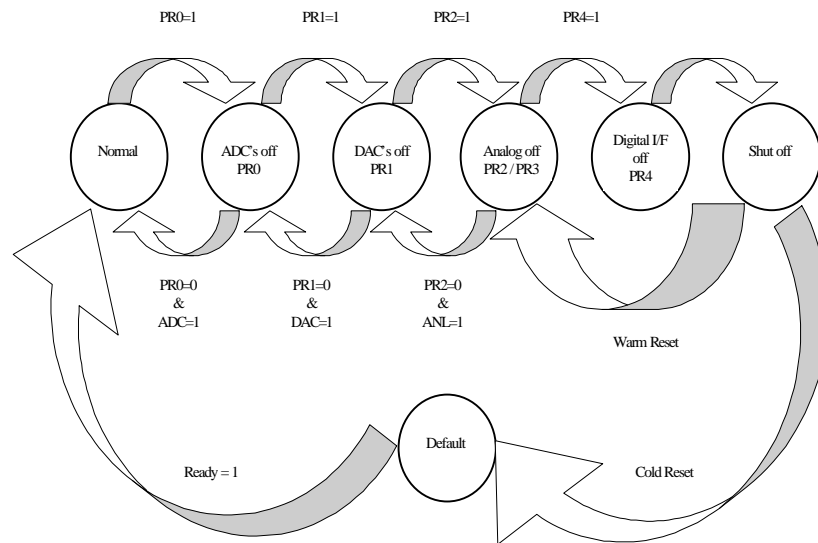
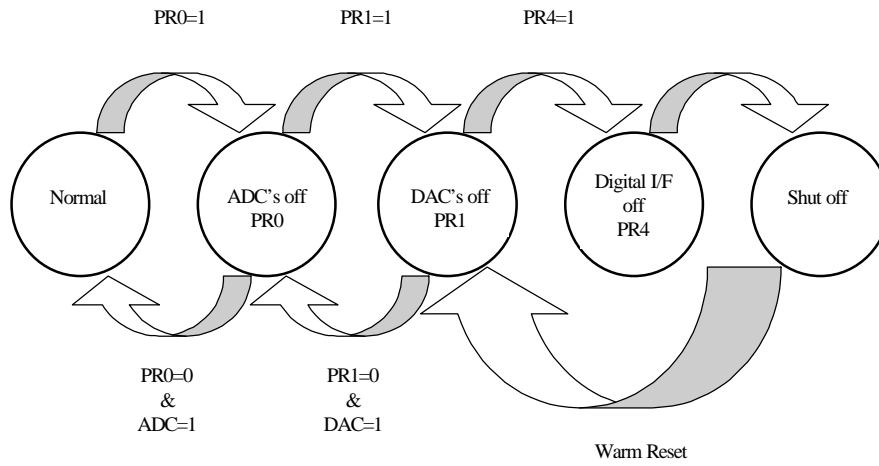

**Figure 10.1: Power down/Power up Procedure**

Note: In the example above, the Analog Mixer has been disabled, but the Vref is still on.

Complete Power Down of the AC'97 device is achieved by sequential writes to the Power Down and Status Control Register (Index 26h):

Normal Operation:	PR<5:0> = 0
ADC's and Input Mux:	PR0 = 1 (write)
DAC's:	PR1 = 1 (write)
Analog Mixer:	PR2 = 1 (write)
Vrefout:	PR3 = 1 (write)
AC-Link:	PR4 = 1 (write)
Internal Clocks:	PR5 = 1 (write)



**Figure 10.2: Power Down Procedure with Analog Section Still Active**

Note: To Power Up the Codec, a Warm Reset or a Cold Reset is required; PR4 is reset to zero upon either reset.



## 11. TEST MODE OPERATION

### 11.1 ATE Test Mode:

PCB In-Circuit Testing of the W83971D

SDATA\_OUT is sampled at the rising edge of RESET# to enter ATE test mode  
SDATA\_IN and BIT\_CLK outputs are driven to a high impedance (Hi-Z) state

Note: this case never occurs during normal operation

### 11.2 Vendor Test Mode:

Vendor test mode is entered when SYNC is sampled at the rising edge of RESET# .

Note: this case never occurs during normal operation

## 12. TYPICAL CONNECTION DIAGRAM

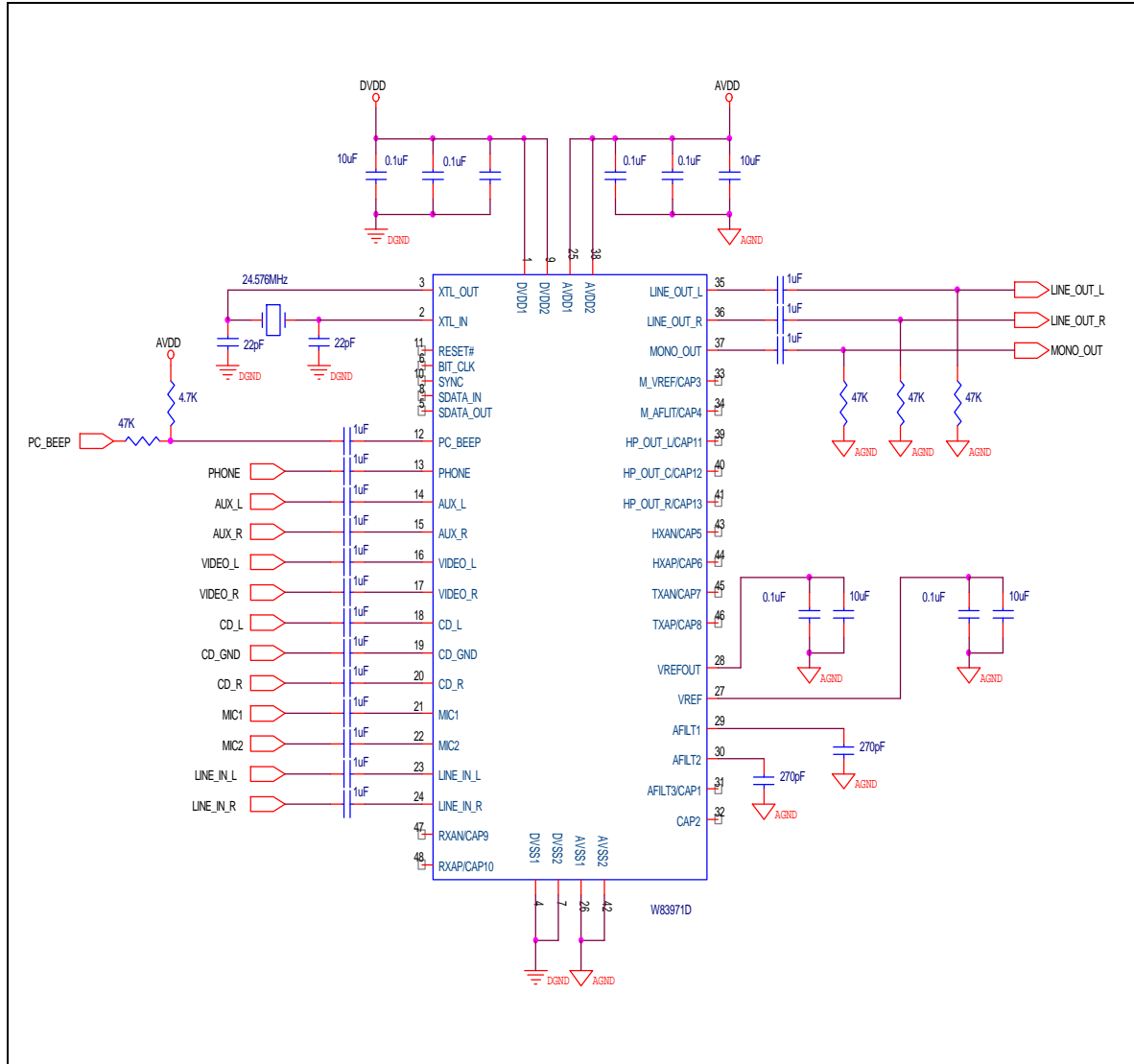

Note: We suggest to use 3.3V digital power and 5.0V analog power. The performance will be better





## 13. HOW TO READ THE TOP MARKING

The top marking of W83781D



Left: Winbond logo

1st line: Type number W83971D, D means LQFP (Thickness = 1.4 mm).

2nd line: Tracking code 745 A A

745: packages made in '97, week 45

A: assembly house ID; A means ASE, O means OSE

A: IC revision; A means version A, B means version B

# Preliminary W83971D



## 14. PACKAGE DIMENSIONS

### 48-pin QFP

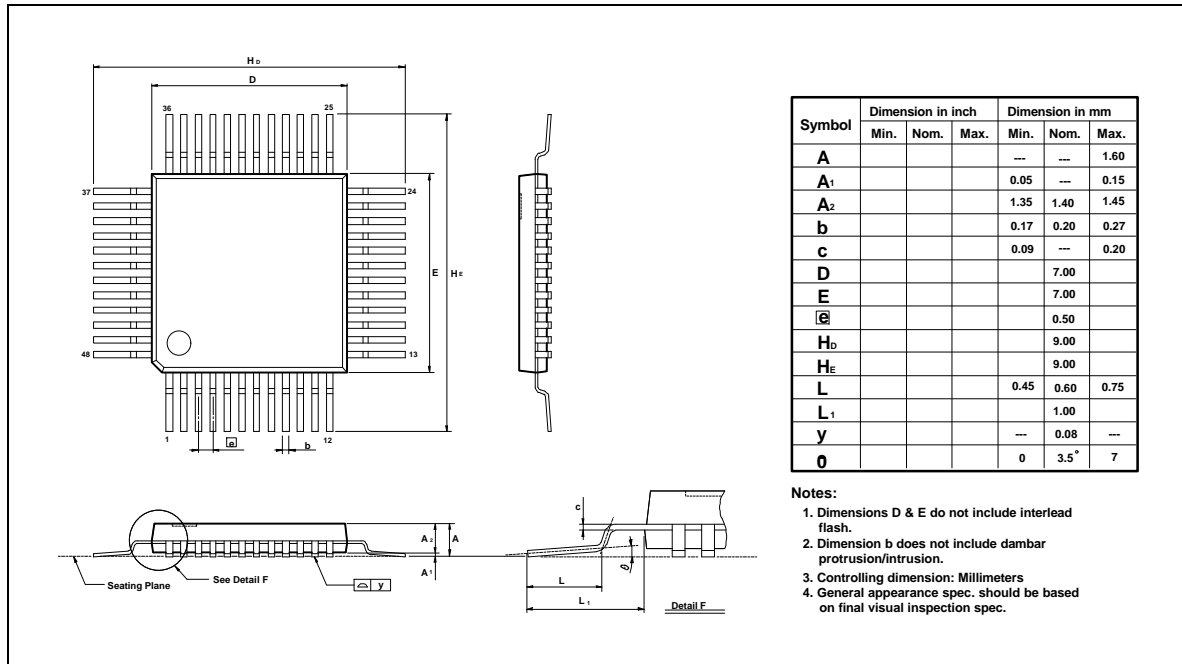

#### Headquarters

No. 4, Creation Rd. III,  
Science-Based Industrial Park,  
Hsinchu, Taiwan  
TEL: 886-3-5770066  
FAX: 886-3-5792646  
<http://www.winbond.com.tw/>  
Voice & Fax-on-demand: 886-2-27197006

#### Taipei Office

11F, No. 115, Sec. 3, Min-Sheng East Rd.,  
Taipei, Taiwan  
TEL: 886-2-27190505  
FAX: 886-2-27197502

#### Winbond Electronics (H.K.) Ltd.

Rm. 803, World Trade Square, Tower II,  
123 Hoi Bun Rd., Kwun Tong,  
Kowloon, Hong Kong  
TEL: 852-27513100  
FAX: 852-27552064

#### Winbond Electronics North America Corp.

Winbond Memory Lab.  
Winbond Microelectronics Corp.  
Winbond Systems Lab.  
2727 N. First Street, San Jose,  
CA 95134, U.S.A.  
TEL: 408-9436666  
FAX: 408-5441798

Note: All data and specifications are subject to change without notice.

Please note that all data and specifications are subject to change without notice. All the trade marks of products and companies mentioned in this data sheet belong to their respective owners.



## 15. APPENDIX A: TEST REPORT

### W83971D ALPHA TEST REPORT (V1.0)

#### Features:

- . 16-bit stereo full-duplex codec with fixed 48KHz sampling rate
- . S/N ratio: 85dB (analog to analog), 75dB (analog to digital), 85dB (digital to analog)
- . Four analog line-level stereo inputs for connection from LINE IN, CD, VIDEO, and AUX
- . Two analog line-level mono inputs for speakerphone and PC BEEP
- . Mono mic input switchable from two external sources
- . High quality pseudo-differential CD input
- . Stereo line-level output
- . Mono output for speakerphone
- . 3D stereo enhancement
- . Multiple Codec Support
- . Power management support
- . Single 5V supply or analog 5V, digital 3V
- . Package: 48-pin LQFP

#### Test Environment:

- . Audio Precision System II, Apwin v1.5
- . Motherboard: Micro Star PII MS\_6119
- . Hard Disk: Quantum Big Foot
- . VGA: Triplex S3 Trio/Virge
- . Test board with ForteMedia sound controller.
- . Windows 95 English.
- . SpectraPlus
- . Sound Forge V4.5
- . Audio Codec Test Program.



## 1. Functionality Test

### 1.1 Playback

. PC(DAC) - LINE_OUT:	ok
. PC_BEEP - LINE_OUT:	ok
. PHONE - LINE_OUT:	ok
. LINE_IN - LINE_OUT:	ok
. CD - LINE_OUT:	ok
. VIDEO - LINE_OUT:	ok
. AUX - LINE_OUT:	ok
. MIXER - MONO_OUT:	ok
. MIC1 - MONO_OUT:	ok
. MIC2 - MONO_OUT:	ok

### 1.2 Record

. PHONE:	ok
. LINE_IN:	ok
. CD:	ok
. VIDEO:	ok
. AUX:	ok
. MIC:	ok
. STEREO:	ok
. MONO_MIX:	ok

### 1.3 Attenuation and Gain

. PC(DAC):	ok
. PC_BEEP:	ok
. PHONE:	ok
. LINE_IN:	ok
. CD:	ok
. VIDEO:	ok
. AUX:	ok
. MIC1:	ok
. MIC2:	ok
. +20 dB of MIC:	ok



1.4 Resets of cold, warm and register: ok

1.5 Power Management: ok

1.6 3D depth function: ok

## 2. Performance

### 2.1 Input Full Scale

. PC_BEEP:	pass
. PHONE:	pass
. LINE_IN:	pass
. CD:	pass
. VIDEO:	pass
. AUX:	pass
. MIC1:	pass
. MIC2:	pass

### 2.2 Output Full Scale

. LINE_OUT:	pass
. MONO_OUT:	pass

### 2.3 Analog SNR (Analog input to Analog output)

. PC_BEEP - LINE_OUT:	pass
. PHONE - LINE_OUT:	pass
. LINE_IN - LINE_OUT:	pass
. CD - LINE_OUT:	pass
. VIDEO - LINE_OUT:	pass
. AUX - LINE_OUT:	pass
. MIC1 - MONO_OUT:	pass
. MIC2 - MONO_OUT:	pass

### 2.4 Analog Frequency Response

. PC_BEEP - LINE_OUT:	pass
. PHONE - LINE_OUT:	pass
. LINE_IN - LINE_OUT:	pass
. CD - LINE_OUT:	pass
. VIDEO - LINE_OUT:	pass
. AUX - LINE_OUT:	pass
. MIC1 - MONO_OUT:	pass
. MIC2 - MONO_OUT:	pass



## 2.5 Digital SNR (For more details, please refer to the attached figures created by using Audio Precision System II)

### D/A (Digital to Analog path)

. PC(DAC) - LINE\_OUT: pass

### A/D (Analog to Digital Record path)

. PHONE: pass

. LINE\_IN: pass

. CD: pass

. VIDEO: pass

. AUX: pass

. MIC: pass

## 2.6 THD+N (Total Harmonic Distortion + Noise)

### A/A (Analog input to Analog output)

. PC\_BEEP - LINE\_OUT: pass

. PHONE - LINE\_OUT: pass

. LINE\_IN - LINE\_OUT: pass

. CD - LINE\_OUT: pass

. VIDEO - LINE\_OUT: pass

. AUX - LINE\_OUT: pass

. MIC1 - MONO\_OUT: pass

. MIC2 - MONO\_OUT: pass

### D/A (Digital to Analog path)

. PC(DAC) - LINE\_OUT: pass

### A/D (Analog to Digital Record path)

. PHONE: pass

. LINE\_IN: pass

. CD: pass

. VIDEO: pass

. AUX: pass

. MIC: pass



## 2.7 D/A Frequency Response (Digital to Analog path)

. PC(DAC) - LINE\_OUT: pass

## 2.8 A/D Frequency Response (Analog to Digital Record path)

. PHONE: pass

. LINE\_IN: pass

. CD: pass

. VIDEO: pass

. AUX: pass

. MIC: pass

## 2.9 Cross Talk between Inputs channels

. LINE\_IN - LINE\_OUT: pass

. CD - LINE\_OUT: pass

. VIDEO - LINE\_OUT: pass

. AUX - LINE\_OUT: pass

. PC(DAC) - LINE\_OUT: pass

## 2.10 Power Consumption

. Analog Power Up 21.7 mA

. Analog Power Down 0.4 mA

. Digital Power Up 68.5 mA

. Digital Power Down 1.8 mA

# Preliminary W83971D



Audio Precision Winbond W83971D A-A 01/12/99 12:03:35  
THD+N (LINE\_IN)

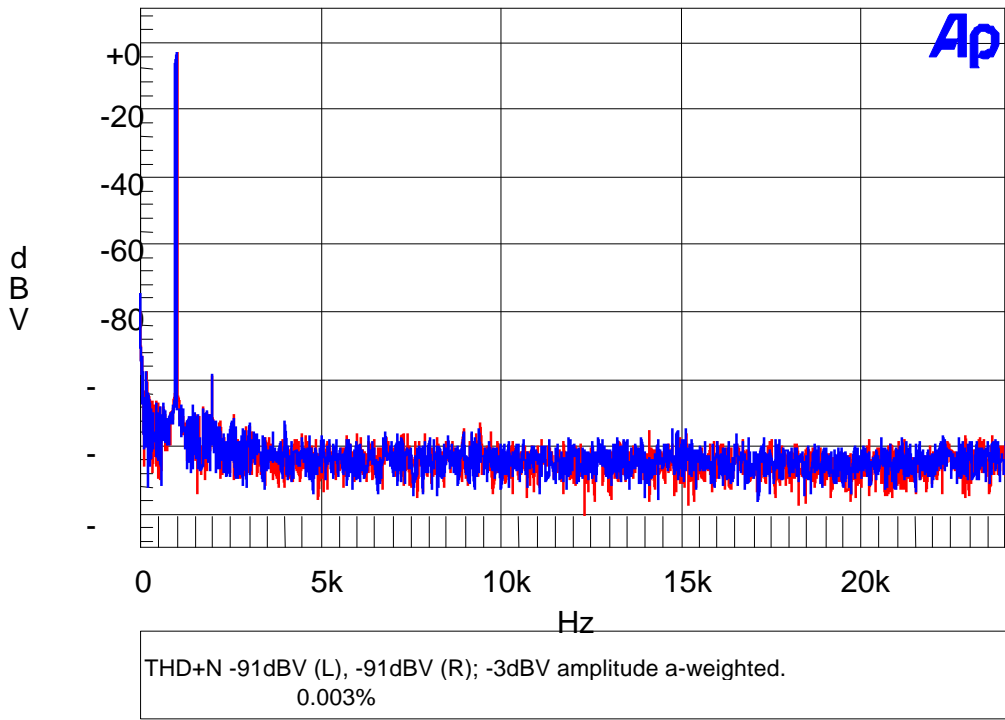

wb\_aa\_line\_in\_thdn-3db.at2



# Preliminary W83971D



Audio Precision Winbond W83971D A-A 01/12/99 11:18:03  
SNR (LINE\_IN)

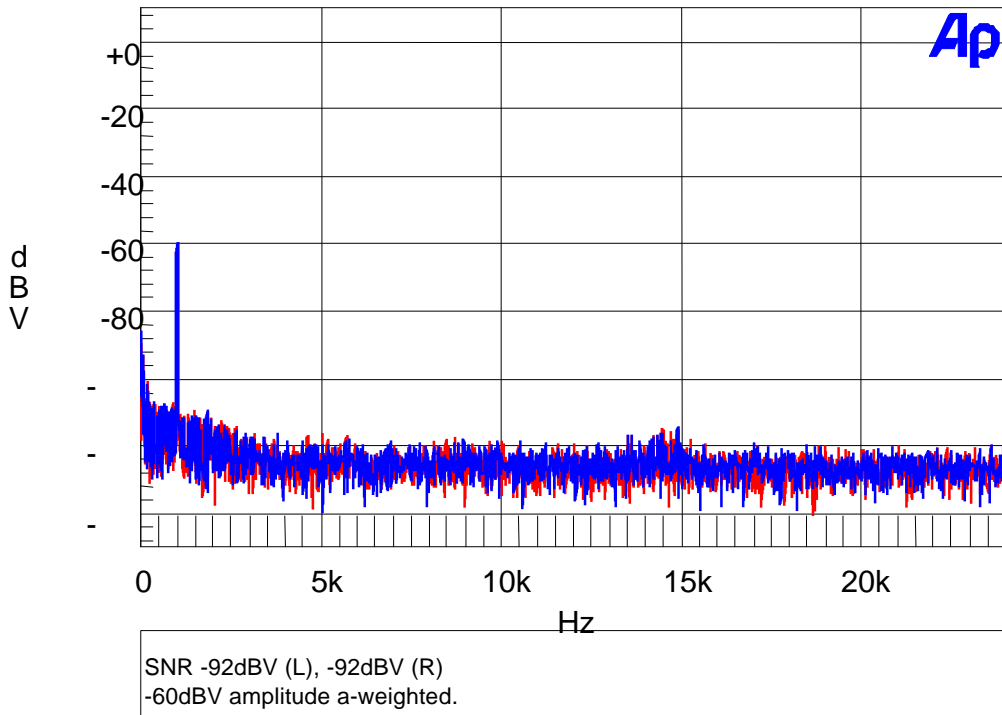

wb\_aa\_line\_in\_snr-60db.at2

# Preliminary W83971D



Audio Precision Winbond W83971D A-A 01/12/99 11:20:03  
Freq Response  
(LINE\_IN)

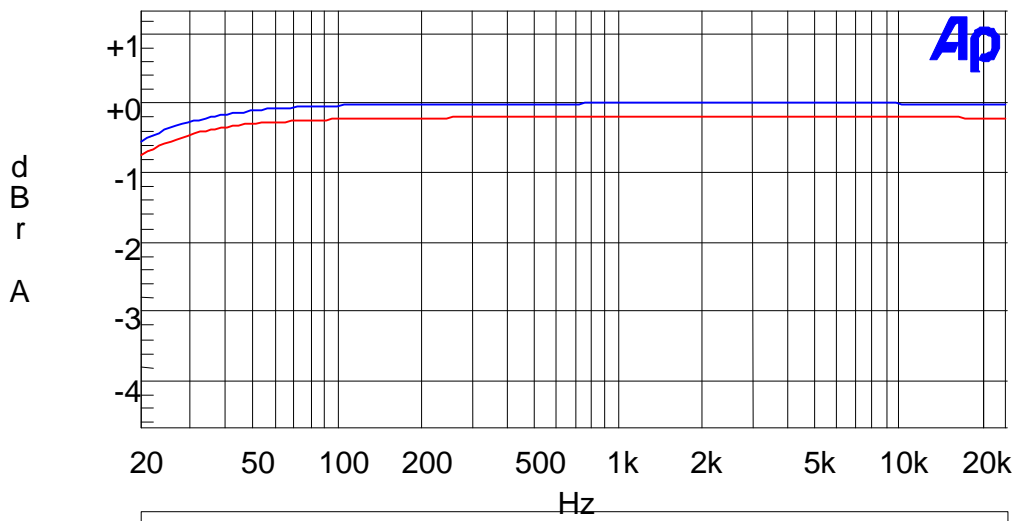

0dBV Frequency Response

wb aa line in fr.at2

# Preliminary W83971D



Audio Precision Winbond W83971D 01/12/99 12:06:04  
A-D-A THD+N (LINE\_IN)

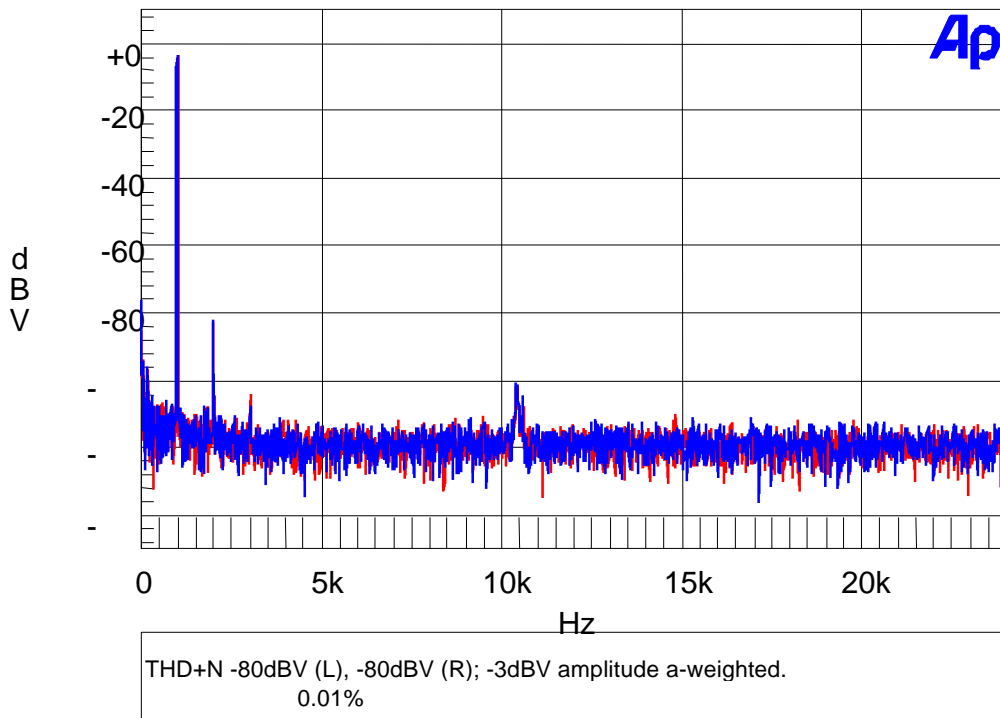

wb\_ada\_line\_in\_thdn-3db.at2

# Preliminary W83971D



Audio Precision Winbond W83971D 01/12/99 11:26:55  
A-D-A SNR (LINE\_IN)

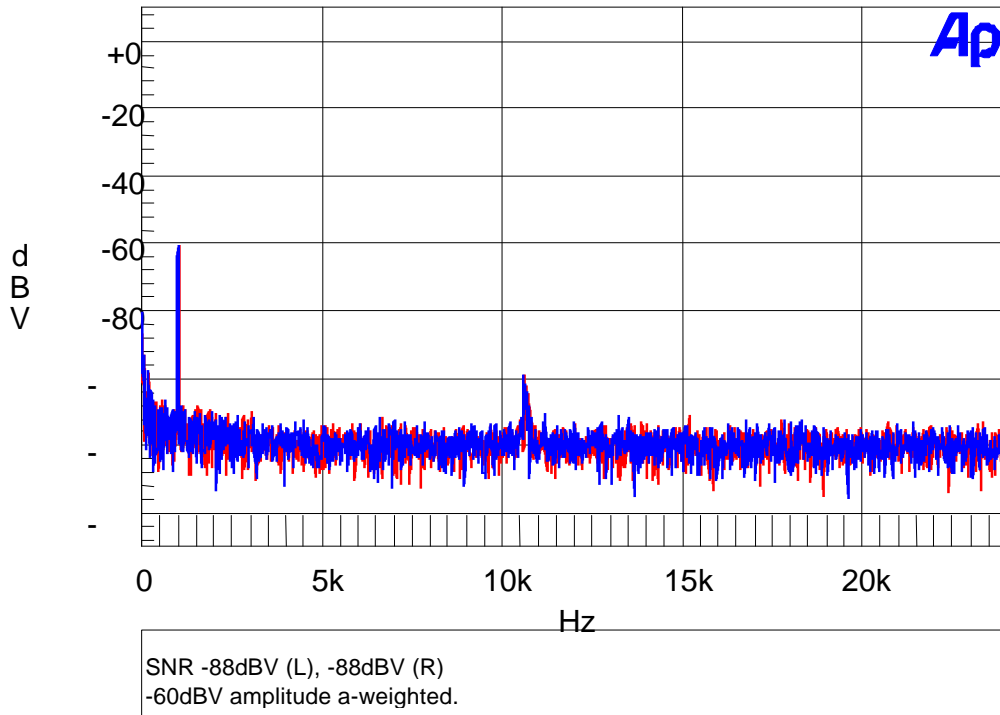

wb\_ada\_line\_in\_snr-60db.at2

# Preliminary W83971D



Audio Precision

Winbond W83971D  
A-D-A Freq Response  
(LINE\_IN)

01/12/99 11:32:26

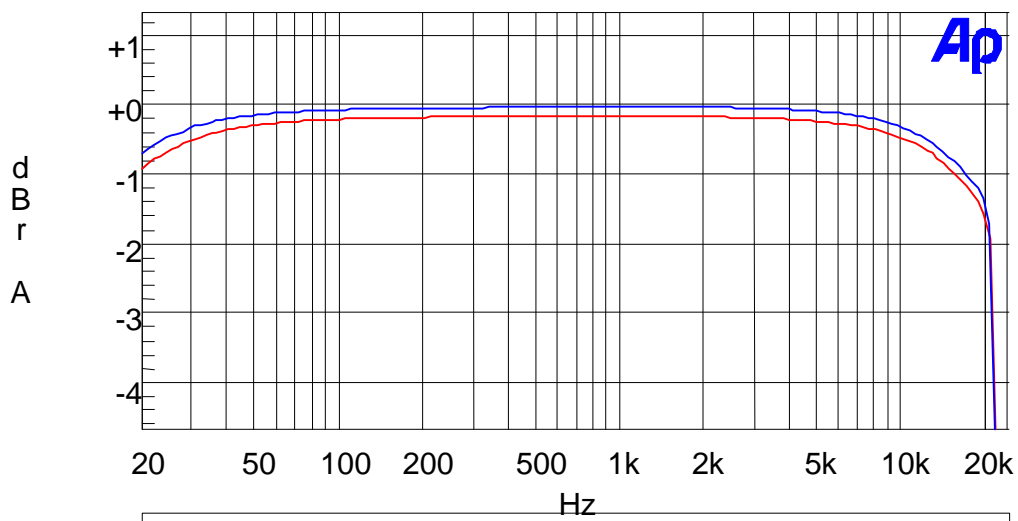

0dBV Frequency Response

wb\_ada\_line\_in\_fr.at2

# Preliminary W83971D



Audio Precision Winbond W83971D D-A 01/12/99 11:56:12  
THD+N (LINE\_IN)

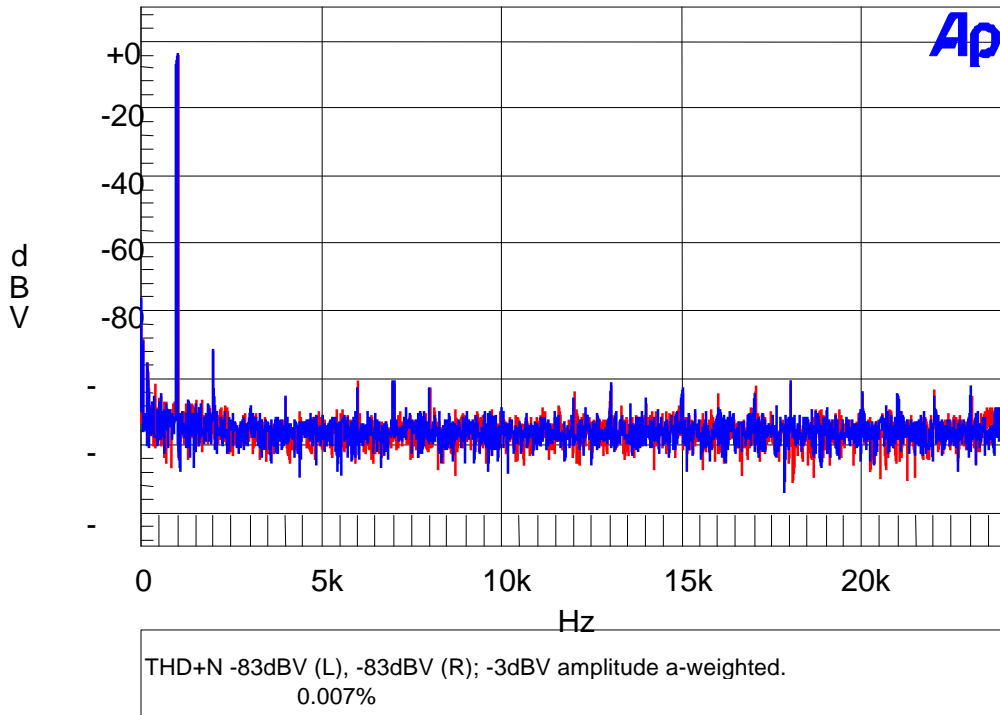

wb da line out thdn-3db.at2

# Preliminary W83971D



Audio Precision Winbond W83971D D-A 01/12/99 11:54:05  
SNR (LINE\_IN)

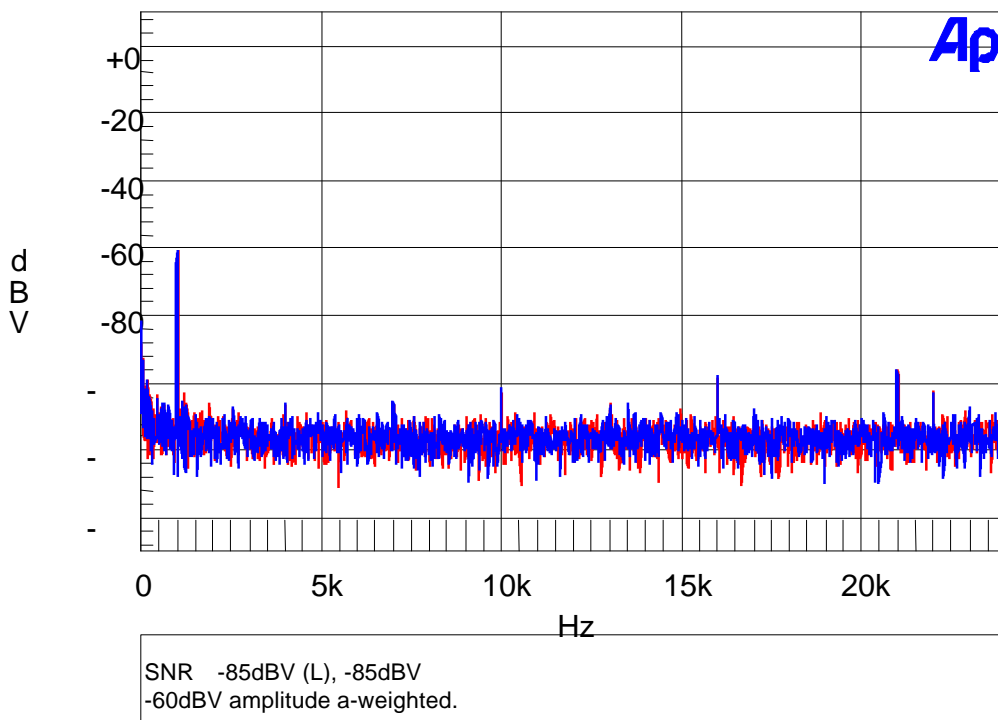

wb\_da\_line\_out\_snr-60db.at2

# Preliminary W83971D



16.

Audio Precision Winbond W83971D D-A 01/12/99 12:00:02  
Freq Response  
(LINE\_IN)

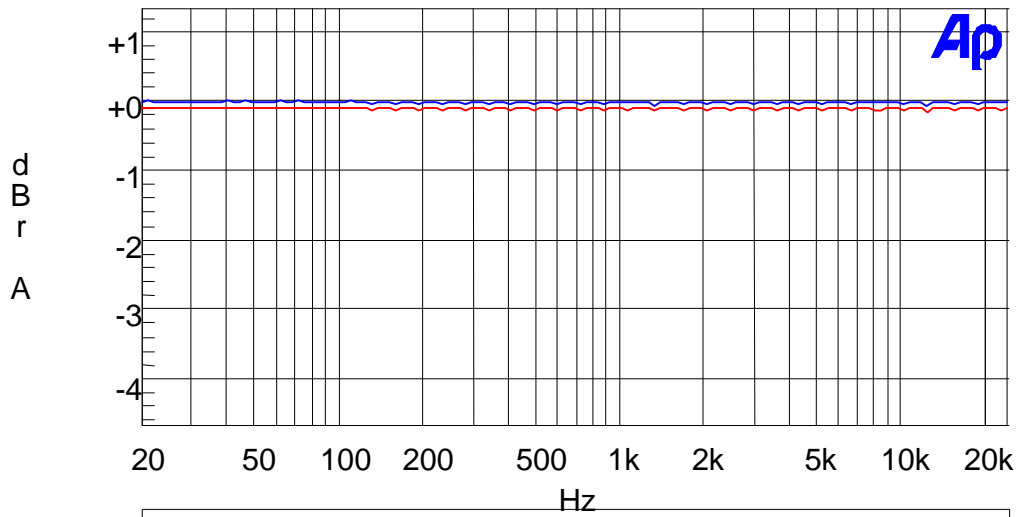

0dB Frequency Response

wb\_da\_line\_out\_fr.at2



## APPENDIX B: LAYOUT GUIDE

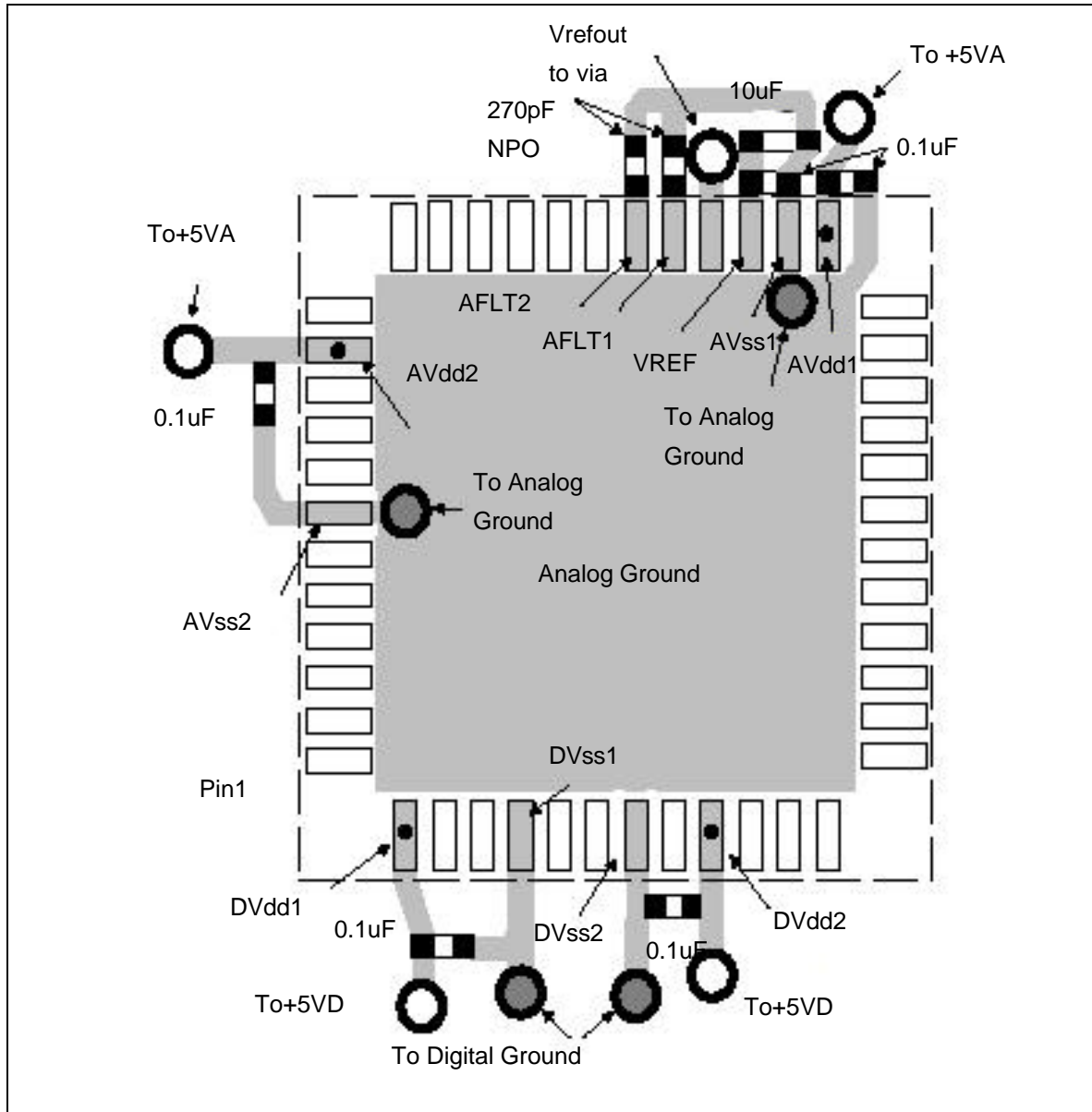

- \* The above figure is the suggested layout for W83971D.
- \* The decoupling capacitors should be located physically as close to the pins as possible.
- \* The device should be located on a locally separate analog ground plane to keep noise from the digital ground return currents from modulating the W83971D" ground potential and degrading performance.

# Preliminary W83971D



- \* The digital ground pins should be connected to the digital ground plane and kept separate from any of the analog ground connections and analog circuitry.
- \* The common connection point between the two ground planes should be located near the W83971D just under the digital ground connections.
- \* The AC-Link digital interface connection traces should be routed such that digital ground plane lies underneath these signals from the AC97 controller continuously to the W83971D.



#### Headquarters

No. 4, Creation Rd. III,  
Science-Based Industrial Park,  
Hsinchu, Taiwan  
TEL: 886-3-5770066  
FAX: 886-3-5792646  
<http://www.winbond.com.tw/>  
Voice & Fax-on-demand: 886-2-27197006

#### Taipei Office

11F, No. 115, Sec. 3, Min-Sheng East Rd.,  
Taipei, Taiwan  
TEL: 886-2-27190505  
FAX: 886-2-27197502

#### Winbond Electronics (H.K.) Ltd.

Rm. 803, World Trade Square, Tower II,  
123 Hoi Bun Rd., Kwun Tong,  
Kowloon, Hong Kong  
TEL: 852-27513100  
FAX: 852-27552064

#### Winbond Electronics North America Corp.

Winbond Memory Lab.  
Winbond Microelectronics Corp.  
Winbond Systems Lab.  
2727 N. First Street, San Jose,  
CA 95134, U.S.A.  
TEL: 408-9436666  
FAX: 408-5441798

Note: All data and specifications are subject to change without notice.