

W89C940



ELANC-PCI (TWISTED-PAIR ETHER-LAN CONTROLLER WITH PCI INTERFACE)

GENERAL DESCRIPTION

The ELANC-PCI (Twisted-pair Ether-LAN Controller with PCI Interface) integrates a W89C902 Serial(ELANC-PCI) LAN Coprocessor for Twisted-Pair (SLCT) and PC/AT PCI bus interface logic into a single chip. The ELANC-PCI provides an easy way of implementing the interface between an IEEE 802.3-compatible Ethernet and a personal computer, ELANC-PCI also provide fast DMA operation to improve the packet transmit and receive performance.

The PCI bus is a high performance local bus architecture with low latency random access time. It is a synchronous bus with operation up to 33MHz. The PCI bus interface is designed to provide the registers with the device information required for configuration, recording the status of the lines, control registers, interrupt line and I/O base address registers. It is capable of functioning in a half-duplex environment.

The W89C940F is designed to fully comply with the standard of PCI 2.0 specification. Taking advantage of PCI's nature, W89C940F supports auto-configuration function to free users' depression and confusion on tuning system resources conflict. With extremely high throughput on PCI bus, W89C940F offers a 32 bits data path to highly boost its performance without extra cost. Comparing with LAN card with ISA bus, its improvement is excellent. Besides, it also supports up to 256KB flash memory reserved for various applications, for instance anti-virus, popular drivers, Boot ROM, viewing your PC assets...etc., and what is more, these software are able to be updated on line. This can increase more niche feature on your LAN card, help you get more and bright your company profile. W89C940F is a single chip - build-in PCI bus interface and all necessary circuits - which will let design and board assembly become easy.

FEATURES

- Fully compatible with IEEE 802.3 standard
- Software compatible with Novell NE2000
- Complies with PCI Local Bus Specification Revision 2.0
- Slave Mode for PCI bus
- Fast DMA operation enhancing network access performance
- AUI, UTP interface available
- Supports one chip 32Kx8 and 16Kx8 SRAM
- Supports up to 64KB boot ROM
- EEPROM auto-load function after power on reset
- EEPROM on-board programming function available
- UTP interface polarity auto detection correction function available
- UTP/BNC auto media-switching function provided
- LED displaying for network segment Link/activity status
- Signature register available for device identification
- Single 5V power supply with low power consumption
- 100 Pin PQFP

W89C940



PIN CONFIGURATION

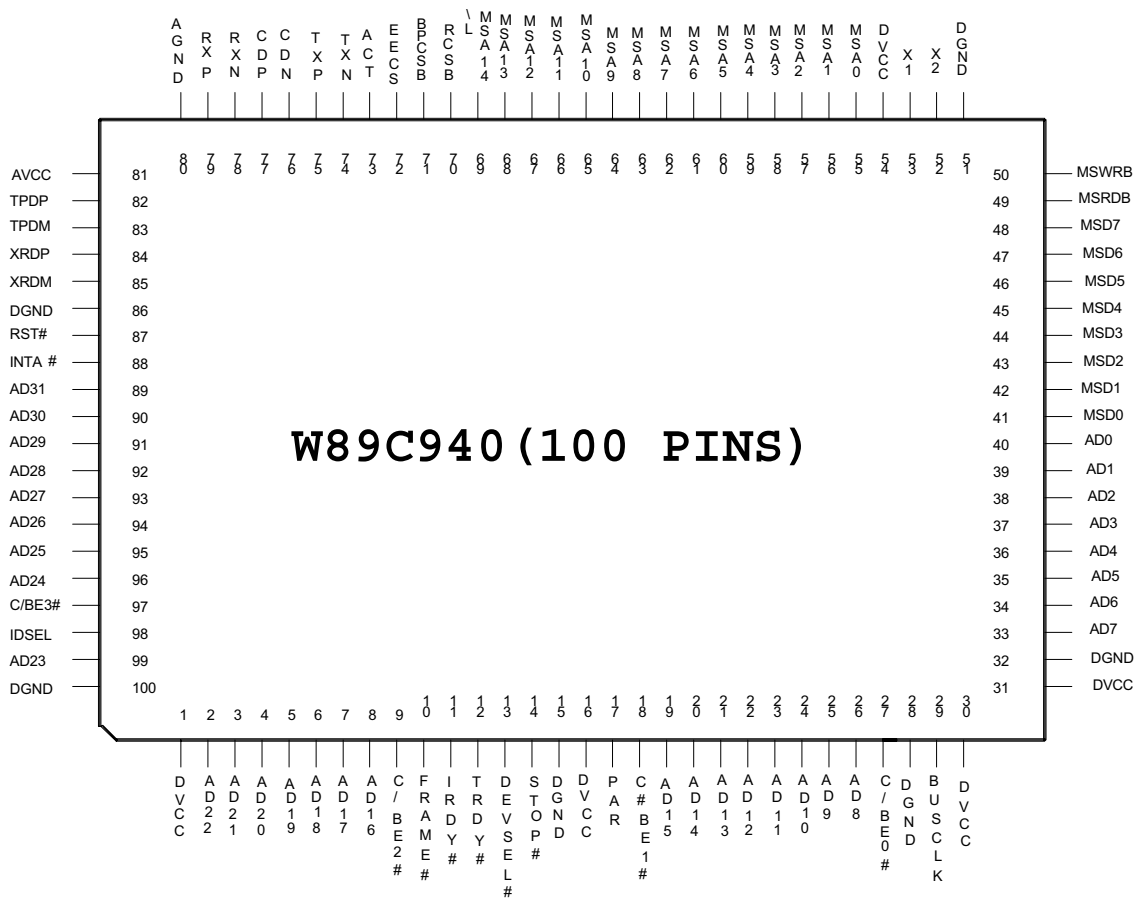



BLOCK DIAGRAM

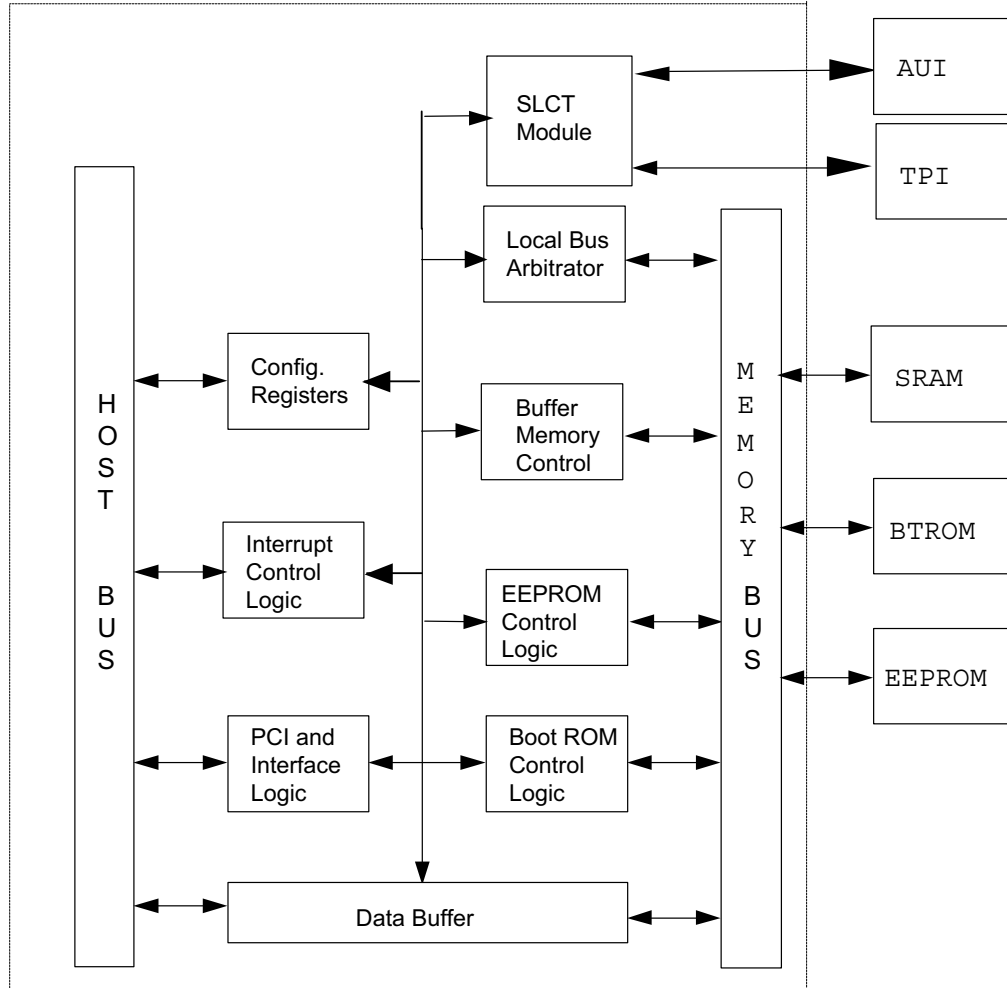



PIN DESCRIPTION

PCI INTERFACE			
NAME	NUMBER	TYPE	DESCRIPTION
CLK	29	in	<p>Clock:</p> <p>Bus clock from PCI bus. All of the PCI signals, except RST#, are synchronized by rising edge of clock.</p> <p>The allowable operating frequency of CLK for W89C940 is from 25MHz to 33MHz.</p>
RST#	87	in	<p>Reset:</p> <p>Asynchronous reset signal from PCI bus.</p>
AD[31:00] AD31- AD24 AD23 AD22- AD16 AD15-AD8 AD7-AD0	89 - 96 99 2 - 8 19 - 26 33 - 40	t/s	<p>Address and Data:</p> <p>Bidirection bus for PCI address and data signals transaction. AD[31:00] is a time division bus. Two phases are used to carry the address and data messages of PCI bus. The address phase is the clock cycle in which FRAME# is asserted.</p> <p>AD[31:24] contains the most significant byte(MSB) and the AD[7:0] contain the least significant byte(LSB) during the data phase.</p> <p>The data written from host should be stable and valid when IRDY# is asserted. The data driven by W89C940 will be stable and valid when TRDY# is asserted.</p>
C/BE[3:0]# C/BE3# C/BE2# C/BE1# C/BE0#	97 9 18 27	t/s in	<p>Bus Command and Byte Enables:</p> <p>C/BE[3:0]# define the type of bus command during the address phase and the byte enables during the data phase of a transaction. There are 16 types of bus command defined in PCI bus. Four bits of C/BE[3:0]# are used to decode the 16 types of bus command. The byte enable determine which byte lanes carry meaningful data.</p> <p>C/BE0# indicate the byte 0(AD[7:0]) is valid. C/BE1# indicate the byte 1(AD[15:8]) is valid. C/BE2# indicate the byte 2(AD[23:16]) is valid. C/BE3# indicate the byte 3(AD[32:24]) is valid.</p>
PAR	17	t/s	<p>Parity:</p> <p>Even parity across AD[31:0] and C_BE[3:0]B.</p> <p>W89C940 will drive the PAR in read data phase. The host drives the PAR for address phase and writes data phase. PAR is stable and valid one clock after the address phase. PAR is stable and valid one clock after either IRDY# is asserted on a write transaction or TRDY# is asserted on a read transaction. Once PAR is valid, it remains valid until one clock after the completion of the current data phase.</p>
FRAME#	10	s/t/s in	<p>Cycle Frame:</p> <p>FRAME# is asserted by host to indicate the beginning of a bus transaction. When FRAME# is deasserted, the transaction is in the final data phase.</p>



PCI INTERFACE			
NAME	NUMBER	TYPE	DESCRIPTION
IRDY#	11	s/t/s in	<p>Initiator Ready:</p> <p>Initiator Ready indicates the host's ability to complete the current data phase of transaction. During a write cycle, IRDY# indicates that valid data is presented on AD[31:00]. During a read cycle, it indicates the master is ready to accept the data. The wait cycles are inserted till IRDY# and TRDY# are asserted at the same cycle.</p>
TRDY#	12	s/t/s	<p>Target Ready:</p> <p>Target Ready indicates the W89C940's ability to complete the current data phase of transaction. During a read cycle, TRDY# indicates that valid data is presented on AD[31:00]. During a write cycle, it indicates the W89C940 is ready to accept the data. The wait cycles are inserted till both IRDY# and TRDY# are asserted at the same cycle.</p>
STOP#	14	s/t/s	<p>STOP:</p> <p>Stop indicates W89C940 is requesting the master to stop the current transaction.</p>
IDSEL	98	in	<p>Initialization Device Select:</p> <p>IDSEL is used as a chip select during PCI configuration read and write transaction.</p>
DEVSEL#	13	s/t/s	<p>Device Select:</p> <p>DEVSEL# will be asserted when W89C940 decode the correct address.</p>
INTA#	88	o/d	<p>Interrupt Request:</p> <p>INTA# is used to request an interrupt service. The interrupt signal can be masked by the register of IMR(Interrupt Mask Register). INTA# status is kept at ISR(Interrupt Status Register).</p>

NETWORK INTERFACE			
NAME	NUMBER	TYPE	DESCRIPTION
X1 X2	53 52	I/TTL O/TTL	<p>Crystal or Oscillator Input.</p> <p>Crystal or oscillator input (X1) and output (X2) pin. If a crystal is used, it should be connected directly to X1 and X2. If an oscillator is selected, X1 is the 20 MHz input and X2 should be left floating.</p>
TXP TXN	75 74	O/AUI	<p>AUI Transmit Output:</p> <p>AUI differential output pair. The data transmitted by DTE will be sent through TXP and TXN in a differential signal with manchest code format. A 270 ohm pull-down resistor is required for each of TXP and TXN. TXP and TXN should be isolated by a pulse transformer from directly connecting outside loop.</p>



NETWORK INTERFACE			
NAME	NUMBER	TYPE	DESCRIPTION
RXP RXN	79 78	I/AUI	AUI Receive Input: AUI differential input pair. The data received by network transceiver will be sent back through RXP and RXN in a differential signal format. The RXP and RXN are also should be isolated by a pulse transformer.
CDP CDN	77 76	I/AUI	AUI Collision Input: AUI differential input pair. The network transceiver will drive a 10MHz differential signal onto CDP and CDN when a collision event is occurred. The CDP and CDN should be isolated by a pulse transformer.
XRDP XRDM	84 85	I/TPI	TPI Receive Input: 10BASE-T receive differential input pair. RXP and RXN should be shunted by a 100 ohms resistor for twisted-pair line impedance matching.
TPDP TPDM	82 83	O/TPI	TPI Transmit Output: 10BASE-T transmit differential output pair. A 1.21K ohm shunt resistor is required across the TXP and TXN for signal pre-equalization.
ACT	73	O/LED	Activity Displaying: Network activity displaying. ACT will indicate the network activity status by three types of signals(DC 0 , DC1 and AC 10Hz). DC 0 : indicating "Link Good", if UTP is selected. DC 1 : indicating 1) "Link fail", if UTP is selected. 2) "idle", if AUI is selected. AC 10HZ : indicating the DTE is transmitting a packet or the carrier on the network is detected by the transceiver and the carrier sense signal is received by W89C940. The ACT will keep DC 1 if there is an abnormal network collision occurred, f.g. the transceiver collision signal always active.

MEMORY INTERFACE			
NAME	NUMBER	TYPE	DESCRIPTION
MSD[7:0]	48 - 41	B/MOS	Local Memory Data Bus: A bidirection bus for data transfer between the local memory and the W89C940. MSD0 is used as a serial data input pin during the auto configuration duration for hardware reset. The data drove by the DO of EEPROM will clocked into the MSD0 when the EEPROM load operation is active. The Ethernet node ID and optional configuration content will be loaded into chip \bar{s} registers at this moment. MSD1 is used as a serial data output pin during the auto configuration duration for hardware reset. The command drove by the MSD1 will be clocked into the DI of EEPROM for accessing the content of EEPROM. MSD2 supplies the clock with a period of 1.2 μ S for EEPROM during auto configuration duration.



MEMORY INTERFACE			
NAME	NUMBER	TYPE	DESCRIPTION
MSRDB	49	O/MOS	Local Memory Read Enable. An active low signal to enable the local SRAM read.
MSWRB	50	O/MOS	Local Memory Write Enable. An active low signal to enable the local SRAM write.
MSA[14:0]	69 - 55	O/MOS	Local Memory Address Bus. Address bus for local memory addressing. The MSA14 will be used as the address strobe signal when the size is larger than 32Kx8. If the ROM size is larger than 32Kx8, Boot ROM address !13-A10 is connected to MSA13-MSA10 and A17-A14 is connected to the latched MSA13-MSA10. The valid address for the higher significant bits(A14,A15,...) will be stable before the BPCSB is active low and should be latched by an external data latch which is triggered by MSA14. The A0 ~ A13 of the BOOT ROM device are connected to MSA0 ~ MSA13 directly no matter the BOOT ROM size is larger than 32Kx8 or not.
RCSB	70	O/MOS	Memory Chip Select: The RCSB is active low. RCSB enables the local memory read/write cycle in conjunction with the MSRDB, MSWRB pins.
BPCSB	71	O/MOS	BOOT ROM Chip Select: BPCSB is active low. BPCSB enables the BOOT ROM read cycle during the system booting up.
EECS	72	O/MOS	EEPROM Chip Select. The EEPROM read/write operation will be enabled when EECS is active high.

POWER PINS			
NAME	NUMBER	TYPE	DESCRIPTION
DVCC	1, 16, 30, 31, 54	I	Digital Power Supply: 5V DC power supply for internal digital logic circuitry.
DGND	15, 28, 32, 51, 86, 100	I	Digital Ground: Ground pins for internal digital logic circuitry.
AVCC	81	I	Analog Power Supply: 5V DC power supply for internal analog circuitry.



POWER PINS			
NAME	NUMBER	TYPE	DESCRIPTION
AGND	80	I	<p>Analog Ground:</p> <p>Ground pin for internal analog circuitry.</p> <p>It is recommended that there is a decoupling capacitor connected between the power supply pins and ground pins. A RC low pass filter is also recommended to be used for analog power supply.</p>

Note: Signal Type Definition

- in Input is a standard input-only signal
- out Totem Pole output is a standard active driver.
- t/s Tri-State is a bi-directional, tri-state input/output pin.
- s/t/s Sustained Tri-State is an active low tri-state signal owned and driven by one and only one agent at a time. The agent that drives an s/t/s pin low must drive it high for at least one clock before letting it float. A new agent cannot start driving a s/t/s signal any sooner than one clock after the previous owner tri-states it. A pull-up is required to sustain the inactive state until another agent drives it, and must be provided by the central resource.
- o/d Open Drain allows multiple devices to share as a wire-OR.



FUNCTIONAL DESCRIPTION

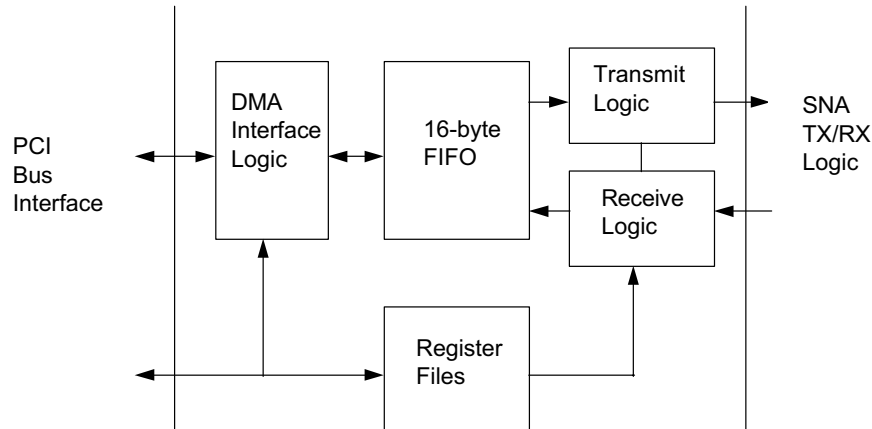

IEEE 802.3 MAC FUNCTION

Core Coprocessor (SLCT) Operation

The SLCT core coprocessor has five major logic blocks that control Ethernet operations: the register files, transmit logic, receive logic, FIFO logic, and DMA logic. The relationship between these blocks is depicted in the following block diagram.

Register Files

The register files of the SLCT can be accessed in the same way as the configuration registers. The ELANC-PCI should be in slave mode when the system accesses the register files. The command register (CR) determines the page number of the register file, while the system address SA<0:3> selects one register address from 01H to 0fH. The PCI IO read/write commands are used to activate the I/O operations. Refer to the W89C90 data sheet for more detailed information on the registers.

DMA Interface Logic

The SLCT has two types of DMA operations, local DMA and remote DMA.

FIFO Logic

The SLCT has a 16-byte FIFO, which acts as an internal buffer to adjust transmission/reception speed differences between DMAs. The FIFO has FIFO threshold pointers to determine the level at which it should initiate a local DMA. The threshold levels are different for reception and transmission. The FIFO threshold levels are defined in the DCR register.

The FIFO logic also provides a FIFO overrun and underrun signal for network management purposes. In a case where the receive packets are flooding into the FIFO but the SLCT still does not have the bus authority, the FIFO may be overrun. On the other hand, if a transmission begins before data are fed into the FIFO, it may be underrun. Both cases result in a network error. These types of cases can be prevented by changing the values of the FIFO thresholds.



Normally, the data in the FIFO cannot be read; reading FIFO data during normal operation may cause the system to hang. In loopback mode, however, the SLCT allows FIFO data to be read by byte in order to check the correctness of the loopback operation.

Receive Logic

The receive logic is responsible for receiving the serial network data and packing the data in byte/word sequence. The receive logic thus has serial to parallel logic in addition to network detection capability.

The ELANC-PCI accepts both physical addresses and group addresses (multicast and broadcast addresses). The SLCT extracts the address field from the serial input data. It then determines if the address is acceptable, according to the configurations defined in the receive configuration register (RCR). If the address is not acceptable, the packet reception is aborted. If the address is acceptable, the data packet is sent to the serial to parallel logic before being fed into the FIFO. Data packets can thus be processed either byte or word-wide.

After receiving a data packet, the SLCT automatically adds four bytes of data receive status, next packet pointer, and two bytes of receive byte count into the FIFO for network management purposes. The receive status contains the status of the incoming packet, so that the system can determine if the packet is desired. The next packet pointer points to the starting address of the next packet in the local receive ring. The receive byte count is the length of the packet received by the SLCT. Note that the receive byte count may be different from the "length" field specified in the Ethernet packet format. These four bytes of data will be transferred to the local buffer with the last batch of the local DMA. However, these four bytes are stored at the first four addresses before the packet.

Transmit Logic

The SLCT must be filled before transmission begins. That is, the local DMA read must begin before the SLCT begins transmission. The SLCT first transmits 62 bits of preamble, then two bits of SFD, and then the data packet. The parallel to serial logic serializes the data from the FIFO into a data packet. After the data packet, the SLCT optionally adds four bytes of cyclic redundancy code (CRC) to the tail of the packet.

A protocol PLA determines the network operations of the ELANC-PCI. Collision detection, random backoff, and auto retransmit are implemented in the transmit logic. The protocol PLA ensures that the ELANC-PCI follows IEEE 802.3 protocol.

10BASE2 AND 10BASE5 PLS (PHYSICAL LAYER SIGNAL) FUNCTION

SNA Operation

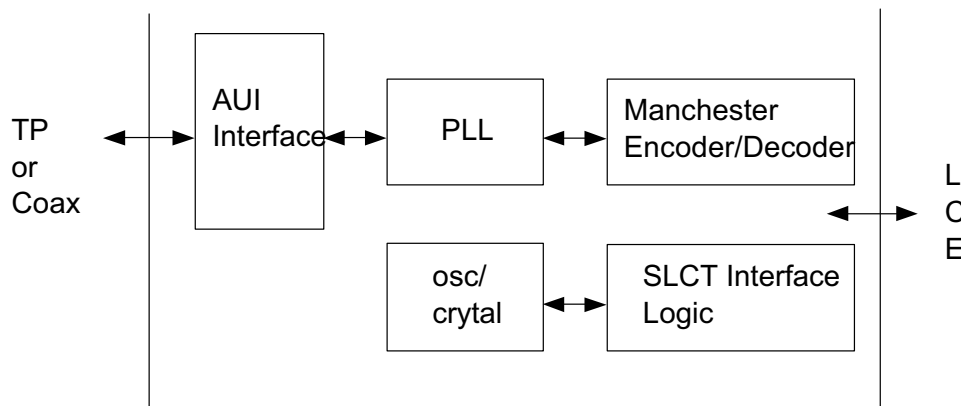



File 1

The ELANC-PCI also contains a Serial Network Adapter (SNA), which adapts the Non-Return-to-Zero (NRZ) used in the core processor and host system to Manchester coded network symbols.

The SNA contains three blocks: a Phase Locked Loop (PLL), a Manchester encoder/decoder, and a collision decoder, as well as crystal/oscillator logic.

The Manchester encoder/decoder handles code interpretation between NRZ signals and Manchester coded signals. The PLL locks the receiving signals with an internal voltage control oscillator (VCO) so that network noise(jitter) can be eliminated before the signals enter the core coprocessor. The collision decoder detects whether the network is in a collision status.

10BASE-T MAU FUNCTION

TP Transceiver Operation

Transmit Driver

There are two signals for data transmission, TXP and TXN, which connect to the twisted-pair cable via a transmitter filter and an optional common mode choke.

Smart Squelch

The main function of this block is to determine when valid data are present on the differential receiving inputs (RXP/RXN). To ensure that impulse noise on the medium will not be taken as a valid datum, this circuit adopts a combination of amplitude and timing measurements to determine the validity of the input signals. To qualify incoming data, the smart squelch circuitry monitors the signals for three peaks of alternating polarity that occur within a 400 nS window. Once this condition has been satisfied, the squelch level is reduced to minimize the noise effect and the chances of causing premature Start Of Idle (SOI) pulse detection. If the receiver detects activity on the receive line while packets are being transmitted, incoming data is qualified on five peaks of alternating polarity so as to prevent false collisions caused by impulse noise. The squelch function returns to its squelch state under any of the following conditions:

- A normal Start Of Idle (SOI) signal
- An inverted SOI signal
- A missing SOI signal

A missing SOI signal is assumed when no transitions have occurred on the receiver for 175nS after a packet has arrived. In this case, a normal SOI signal is generated and appended to the data.

Collision Detection

A collision occurs when transmit and receive signals occur simultaneously on the twisted pair cable. Collisions will not be reported when the device is in link-fail state. The collision signal is also generated when the transceiver has detected a jabber condition or when the SQE test is being performed.

SQE test

The Signal Quality Error (SQE) test is used to test the collision signaling circuitry in the Twisted Pair Transceiver module. After each packet transmission, an SQE signal is sent to the SLCT. The SLCT expects this signal and will flag an error if it does not exist.

Jabber

The jabber timer monitors the transmitter and disables the transmission if the transmitter is active for greater than 26.2 mS. The jabber will re-enable the transmitter after the SLCT has been idle for at least 420 mS.



Link Integrity

During periods of inactivity, link pulses are generated and received by both MAUs at either end of the twisted pair to ensure that the cable has not been broken or shorted. A positive, 100 nS Link Integrity signal is generated by the Twisted Pair Transceiver and transmitted on the twisted pair cable every 13 ms during periods of no transmission activity. The ELANC-PCI assumes a link-good state if it senses valid link pulse activity on the Twisted Pair Transceiver receive circuit. If neither receive data nor a link pulse (positive or negative) is detected within 105 mS, the ELANC-PCI enters link-fail state. When a link-fail condition occurs, four consecutive positive link pulses (or eight negative link pulses) must be received before a link-good condition is assumed.

LCE CORE ACCESS FUNCTION

LCE core access function (LCE: Lan Controller of Ethernet)

The LCE core of the ELANC-PCI can be accessed by programming the register of the LCE core. The ELANC-PCI's register files are mapped into the lower 16 I/O spaces: iobase to iobase+0FH. Any read/write to the ELANC-PCI's registers is an "IN"/"OUT" command to these addresses.

Addresses iobase+10H to iobase+17H are mapped to the I/O port for the system to access the contents of the buffer memory. Remote DMA reads and writes correspond to "IN"/"OUT" commands to these addresses.

When addresses iobase+18H to +1FH are read a software reset will be issued to the core coprocessor and released about 780nsec later, automatically.

The following table summarizes the I/O address mapping:

ADDRESS	REGISTER	OPERATION
iobase+00H - iobase+0FH	LCE core's registers	Slave register read/write
iobase+10H - iobase+17H	I/O Ports	Remote DMA read/write
iobase+18H - iobase+1FH	Reset	Software reset

The buffer memory map for LCE core memory address space is summarized in the following table:

NE2000 COMPATIBLE	
0000H - 001FH	ID Registers
0020H - 00FFH 0100H - 3FFFH	Unused
4000H - 7FFFH	16K X 8 local memory
8000H - FFFFH	Unused

NODE ID

Each node in an Ethernet network has a unique six-byte ID. The node ID is mapped into the memory space of the ELANC-PCI. The ELANC-PCI will load the node ID from the EEPROM after power on reset. The node I.D. should be allocated in the first 3 words (with the address of 00H ~ 02H) of the EEPROM.



Bus Arbitration

The ELANC-PCI handles bus arbitration automatically. The LAN card can operate in four modes: idle state, slave read/write mode, DMA mode, and PCI mode. The ELANC-PCI controls the on-board devices by decoding these modes.

At power on, the ELANC-PCI is in idle mode. If a register read/write command is issued, the ELANC-PCI enters the slave read/write mode. If a local DMA or remote DMA is initiated by the ELANC-PCI core coprocessor, the ELANC-PCI enters DMA mode. A PCI command will put the ELANC-PCI into PCI mode. At any given time, the ELANC-PCI can be in only one state. The ELANC-PCI handles state changes automatically. However, two events, such as a DMA command and an PCI command, may be requested at the same time; in this case, the ELANC-PCI allocates the bus on a first-come, first-served basis. No predefined priority is set within the ELANC-PCI.

NE2000 MODE DMA FUNCTION

The ELANC-PCI provides two DMA channels for system access. The remote DMA mode moves data between system memory space and local memory space. The local DMA moves data between the FIFO of the SLCT and local memory space. However, since the SLCT can handle local DMA operations without system intervention (refer to the data sheet for the SLCT), the system has to perform only remote DMA reads/writes.

In a transmit operation, the data should be moved to local memory before the system orders the SLCT to start transmission. The remote DMA write moves the data from the PCI bus to the local SRAM. This is simply an "OUT" command on the PC. For a receive operation, the network may feed data constantly and the local memory may become full if the data are not moved out to system memory through a remote DMA read operation. This operation is the "IN" command on the PC.

Remote DMA

A remote DMA can be performed only in I/O mode. The remote DMA moves data between the host and the local buffers. Unlike a local DMA, the remote DMA is byte or word-wide. Each remote DMA operation transfers four bytes, double-word, depending on the PCI cycle.

Since the remote DMA is simply an PCI I/O operation, PCI is sometimes affected by a remote DMA. If the remote DMA is interleaved with other devices, TRDY# is deasserted to force the system to insert wait states. The ELANC-PCI will automatically handle any arbitration necessary.

A Double word access on W89C940 from PCI bus is allowed. The buffer memory access will stop when the Remote Byte Counter is decreased to zero. A double word read command will read only three bytes of valid data if remote byte counter is set 3 or two bytes of valid data if the remote byte counter is set 2 respectively.

Local DMA

The local DMA transfers data from/to the on-board buffers. To perform data reception or transmission from/to remote nodes in the network, data must be moved from/to the FIFO. To enhance the efficiency of the transmission, the local DMA transfers data in batches: Data are first collected and then moved in a batch. Each transfer can move up to 12 bytes of data at once. This scheme reduces time wasted in requesting the bus.

A local DMA begins by requesting the local bus. If the bus is available to the ELANC-PCI, it responds at once by asserting the bus acknowledge; if, on the other hand, the bus is currently authorized to another device, the ELANC-PCI will not assert the bus acknowledge and the SLCT must wait. Note that this sequence will not affect the host system or the PCI bus signals. After each batch is transferred, the SLCT checks the FIFO threshold levels to determine if another batch transfer should be requested.



BOOT PROM ACCESS FUNCTION

Boot PROM Operation

For diskless applications, the system requires an on-board boot device. The ELANC-PCI allows the system to use an on-board BOOT PROM as the boot device.

The BOOT PROM is essentially a byte-read device. ELANC-PCI will fetch a byte from the BOOT PROM and drive the AD bus of the PCI Interface. If the system do a word read command, the ELANC-PCI will invoke two byte read operation with consecutive address and drove the second byte on another byte of the PCI interface. For double word command, the ELANC-PCI will deassert the TRDY# until four read operation with consecutive address to the BOOT PROM is completed and then the four bytes of data will be drove onto the 32 bits data bus of PCI.

W89C940 can support the EPROM and Flash memory with 220nsec access time with the size up to 256KB. In order to support 64KB, 128KB and 256KB size with 15-bit address bus, W89C940 use MSA14 to latch the high address bits MSA[17:14] from MSA[13:10]. The structure for address latch is shown as following.

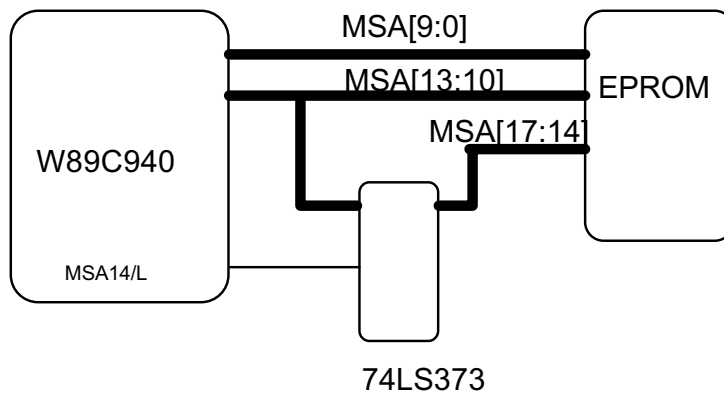



CONFIGURATION PROGRAMMING FUNCTION

ELANC-PCI Mode Configuration Registers

MCR

A mode configuration register(MCR) is used to program the operation mode of the ELANC-PCI. The address is page 0, 0AH. MCR can be updated by software. Reading this register is the same as reading a register in the SLCT core coprocessor. Writing to these registers is done by first reading the register to be written to and then using a slave write operation to update the configurations.

The content of MCR is as following table:

BIT	SYMBOL	DESCRIPTION
0 1	PHY0 PHY1	Physical Layer Interface: These two bits select the type of physical interface which the ELANC-PCI attached on. Both the thin Ethernet and thick Ethernet type use the AUI of ELANC-PCI as the input/output interface. The other two UTP types, then, use the TPI of ELANC-PCI as the input/output interface. The output and input pins of AUI or TPI are idle, when the corresponding type is not selected. PHY1 PHY0 Physical Interface Type 0 0 UTP (with 10BASE-T compatible receive squelch level) 0 1 Thin Ethernet 1 0 Thick Ethernet (AUI port) 1 1 UTP (with reduced receive squelch level)
2	GDLNK	Good Link Status: A read operation on this bit will get the link test status. A "1" indicate that it is link good and a "0" is link fail. The GDLNK do not imply any information if the PHY0 and PHY1 is programmed as Thin or Thick Ethernet.
3	LNKEN	Link Test Pulse enable: The network media auto switching function, link integrity test function and the link test pulse generation function will be enabled when LNKEN = "0". Otherwise, all of these functions will be disabled when LNKEN = "1".
4	SHLS	SRAM High/Low Speed Select: High speed SRAM with 20nsec access time is selected if SHLS =1. Low speed SRAM with 70nsec access time is selected if SHLS =0.
5 6 7	BPS0 BPS1 BPS2	BOOT PROM Size: The size of the BOOT PROM is selected by BPS0, BPS1, and BPS2. BPS2 BPS1 BPS0 SIZE 0 0 X No boot PROM 0 1 0 8K 0 1 1 16K 1 0 0 32K 1 0 1 64K 1 1 0 128K 1 1 1 256K



PCI Bus Operation Configuration Registers

The W89C940 implement a system configuration registers for PCI bus auto configuration function. The W89C940 support the predefined header portion of the system configuration space (i.e. first 64 bytes of the 256 bytes configuration space). A summarized table for those registers is as following.

address of configuration space	Register	Attribute	Default Value after power ON	Write By
01H~00H	Vendor-ID	R/W	1050H	EEPROM
03H~02H	Device-ID	R/W	5A5AH	EEPROM
05H~04H	Command	R/W	0000H	System S/W
07H~06H	Status	R/W	0280H	System S/W
08H	Revision-ID	R/W	00H	EEPROM
0BH~09H	Class-Code	R	020000H	None
0CH	Cache-Line-Size	R	00H	None
0DH	Latency-Timer	R	00H	None
0EH	Header-Type	R	00H	None
0FH	BIST	R	00H	None
13H~10H	I/O-Base-Address	R/W	FFFFFFE1H	System S/W
17H~14H	Reserved-Reg.-0	R	00000000H	None
1BH~18H	Reserved-Reg.-1	R	00000000H	None
1FH~1CH	Reserved-Reg.-2	R	00000000H	None
23H~20H	Reserved-Reg.-3	R	00000000H	None
27H~24H	Reserved-Reg.-4	R	00000000H	None
2BH~28H	Reserved-Reg.-5	R	00000000H	None
2FH~2CH	Reserved-Reg.-6	R	00000000H	None
33H~30H	ROM-Base-Address	R/W	FFF8001H	System S/W
37H~34H	Reserved-Reg.-7	R	00000000H	None
3BH~38H	Reserved-Reg.-8	R	00000000H	None
3CH	Interrupt Line	R/W	00H	System S/W
3DH	Interrupt Pin	R	01H	None
3EH	Min-Gnt	R/W	00H	EEPROM
3FH	Max-Lat	R/W	00H	EEPROM

The vendor ID, device ID, revision ID, Min-Gnt and Max-Lat are programmed by EEPROM, i.e. the contents of these register can be updated by EEPROM load only. The I/O base address and the ROM base address registers can be updated by system software. Those system configuration registers should be accessed by a double word access operation. The W89C940 will drive 32 bits data on the bus when these configuration registers are accessed.

Vendor ID Register

The vendor I.D. identifies the manufacturer of the device. Valid vendor identifiers are allocated by the PCI SIG to ensure uniqueness. The content of this register will be updated after power on by the EEPROM load operation. The vendor ID should be programmed into the word with 09H address of the EEPROM for power on auto loading.

W89C940



Device I.D. Register

The device I.D. identifies the particular device. This identifier is allocated by the vendor. The content of this register will be updated after power on by the EEPROM load operation. The device ID should be programmed into the word with 0AH address of the EEPROM for power on auto loading.

Command Register

Bit Location	Attribute	Description
0	R/W	This bit controls the I/O space access response of W89C940. A value of "0" will disable the W89C940 response. A value of "1" allows the W89C940 to respond to I/O space accesses.
1	R/W	This bit controls the memory space access response of W89C940. A value of "0" will disable the W89C940 response. A value of "1" allows the W89C940 to respond to memory space accesses.
2	R	The W89C940 do not support PCI bus master function. This bit is fixed to "0".
3	R	The W89C940 do not support the special cycle operation. This bit is fixed to "0".
4	R	The W89C940 do not support the memory write cycle and the invalidate command. This bit is fixed to "0".
5	R	The W89C940 is not a VGA compatible device. This bit is fixed to "0".
6	R/W	This bit controls the parity error response of W89C940. A value of "0" will force the W89C940 ignore a parity error. A value of "1" allows the W89C940 to take a normal action when a parity error is detected. This bit will be reset after power ON.
7	R	The W89C940 do not support data stepping function and this bit is fixed to "0" always.
8	-	This bit is an enable bit for W89C940 internal SERR# driver. A value of "0" will disable the internal SERR# driver. A value of "1" enables the internal SERR# driver.
9~15	R	All of these bits are fixed to "0" internally. And no specific function are related to these bits.



Status Register

Bit Location	Attribute	Description
15	R/W	This bit will be set "1" by W89C940 when it detects a parity error, even if parity error handling is disabled(as controlled by bit 6 in the command register). A "write 1" operation on this bit will clear this bit. This bit will be set "0" after it is cleared.
14	R/W	This bit will be set "1" by W89C940 when it assert the internal SERR#. A "write 1" operation on this bit will clear this bit. This bit will be set "0" after it is cleared. This bit is read only for 100 pin package and is fixed to "0".
13	R	The W89C940 do not support PCI bus master function. This bit is fixed to "0".
12	R	The W89C940 do not support PCI bus master function. This bit is fixed to "0".
11	R/W	This bit will be set "1" by W89C940 when it terminates a transaction with target-abort. A "write 1" operation on this bit will clear this bit. This bit will be set "0" after it is cleared.
10~9	R	The Bit-10 is fixed to "0" and Bit-9 is fixed to "1". It indicated that the W89C940 assert the DEVSEL# with medium speed.
8	R	The W89C940 do not support PCI bus master function. This bit is fixed to "0".
7	R	The W89C940 support fast back-to-back transaction.
6~0	R	All of these bits are fixed to "0" internally. And no specific function are related to these bits.

There are two cases that the W89C940 will initiate the target-abort. The first one is the addressing parity check error cause internal SERR# asserted but without STOP# signal and the second one is the byte enable and address check error that the STOP# is asserted. If addressing don't match the following table, the target doesn't transfer the data, but terminate with target abort.

AD1	AD0	C/BE3#	C/BE2#	C/BE1#	C/BE0#
0	0	X	X	X	0
0	1	X	X	0	1
1	0	X	0	1	1
1	1	0	1	1	1

Revision I.D. Register

The revision I.D. is chosen by the vendor. It specifies a device specific revision identifier. Zero is an acceptable value. It can be viewed as a vendor defined extension to the Device I.D. The content of this register will be updated after power on by the EEPROM load operation. The revision ID should be programmed into the 23th byte of the EEPROM for power on auto loading.



Class Code Register

The Class Code Register is read only. The code of 020000H indicates that the W89C940 is a Ethernet controller.

Cache-Line-Size Register

The W89C940 do not support the Memory Write and Invalidate command. All bits of this register are fixed to "0".

Latency-Timer Register

The W89C940 do not implement a writable latency timer. All bits of this register are fixed to "0".

Header-Type Register

The W89C940 is a single function device. The bit 7 of header type register is fixed to "0" and all of other bits of this register are also fixed to "0".

BIST Register

The W89C940 do not support the built in self test function. It will always return "00H" for a reading operation.

I/O-Base-Address Register

Bit	31~24	23~16	15~8	7	6	5	4	3	2	1	0
Attribute	R/W	R/W	R/W	R/W	R/W	R/W	R	R	R	R	R
Initial Value	FFH	FFH	FFH	1	1	1	0	0	0	0	1

The bit 0 fixed to "1" indicates that W89C940 requires the I/O space of the system as its buffer for data transfer. The bit 0 to bit 4 implemented as a read only field imply that W89C940 need a I/O space with a range of 32 bytes. The power-up software can determine how much address space the device required by writing a value of all 1's to the register and then reading the value back. The W89C940 will return 0's in all don't care address bits(bit 0 ~ bit 4), effectively specifying the address required, if the IDSEL and the configuration command are recognized. The I/O base address will be decided by the bit 5 to bit 31 of the I/O base address register. The system software should write the base address(32 bits address) onto this register. The bit 0 to bit 4 will be ignored by W89C940. The bit 5 to bit 31 will be used as a reference value of the address decoder of the W89C940.

There are nine types of command decoded by C/BE[0:3]# during the address phase of a transaction. These nine types of command are as the following table.

C/BE[3:0]#	Command Type
0010	I/O Read
0011	I/O Write
0110	Memory Read
0111	Memory Write
1010	Configuration Read
1011	Configuration Write
1100	Memory Read Multiple, this command will be decoded as the Memory Read command
1110	Memory Read Line, this command will be decoded as the Memory Read command
1111	Memory Write and Invalidate, this command will be decoded as the Memory Write command

The last three commands are used in cache memory access. The application of W89C940 do not support this command.



ROM-Base-Address Register

Bit	31~24	23~16	15~8	7~0
Attribute	R/W	R/W	R/W	R/W
Initial Value	FFH	FFH	80H	01H

The W89C940 supports 8Kx8, 16Kx8, 32Kx8, 64Kx8, 128Kx8 and 256Kx8 ROM address decoding function. For a 8Kx8 ROM application, the upper 19 bits of this register correspond to the upper 19 bits of the expansion ROM base address. The lower 13 bits of this register correspond to the size of the expansion ROM. Those bits correspond to the size of the expansion ROM are determined by MCR bit 5, bit 6 and bit 7 and can not be writable by the system configuration write command. The device independent configuration software can only determined the bits corresponding to the base address. The following table describe the relationship between the addressing bus, sizing bits and the MCR bit 5/6/7.

MCR.7	MCR.6	MCR.5	Addressing Bits	Sizing Bits	ROM Size
0	0	X	None	None	No BOOT ROM
0	1	0	31~13	12~0	8Kx8
0	1	1	31~14	13~0	16Kx8
1	0	0	31~15	14~0	32Kx8
1	0	1	31~16	15~0	64Kx8
1	1	0	31~17	16~0	128Kx8
1	1	1	31~18	17~0	256Kx8

The device independent configuration software can only determined the addressing bits. The bit 0 of the ROM base address register will be reset "0" by W89C940 if the MCR is set as "No BOOT ROM", i.e. BPS0=0, BPS1=0 and BPS2=0. The bit 0 of the ROM base address register will be set "1" if the MCR is programmed as there is an expansion ROM device add-on the LAN adapter. The initial value of FFFF8001H indicates that there is a 32Kx8 expansion ROM device existing. The initial value is changed according to the BOOT ROM size selection in the MCR (Mode Configuration Register).

Interrupt Line Register

This register is a readable and writable register. The POST software of system could write the routing information into this register as it initializes and configures the system. The value in this register tells which input of the system interrupt controllers the device's interrupt pin i connected to. Device drivers and operating systems can use this information to determine priority and vector information. For x86 based PCs, the value in this register correspond to IRQ numbers (0-15) of the standard dual 8259 configuration. The value 255 is defined as meaning "unknown" or "no connection" to the interrupt controller. Values between 15 and 255 are reserved.

Interrupt Pin Register

The W89C940 use the INTA# as its interrupt pin. The content of this register is fixed into "01".

Min-Gnt Register

It is used for specifying how long a burst period the device needs assuming a clock rate of 33MHz. The content of this register will be updated after power on by the EEPROM load operation. The Min-Gnt should be programmed into the 17th byte of the EEPROM for power on auto loading.



Max-Lat Register

It is used for specifying how often the device needs to gain access to the PCI bus.

MAX_LAT is used to set the devices desired settings for Latency Timer values. The registers specify the values in units of 0.25 microsecond. Zero means the device has no major requirements for the settings of Latency Timer. The content of this register will be updated after power on by the EEPROM load operation. The Max-Lat should be programmed into the 18th byte of the EEPROM for power on auto loading.

EEPROM PROGRAMMING FUNCTION

EEPROM Load and Reload procedure

A EEPROM control register(ECR) is used to control the operation mode of the EEPROM. The ECR is allocated on the register address of page 3, 02H of LCE. The content of ECR is as following table:

BIT	SYMBOL	DESCRIPTION
0-5		Reserved
6	ERWS	EEPROM Read Write Select: The write sequence to EEPROM is selected If ERWS = 1. If ERWS = 0, the read sequence is selected.
7	EAC	EEPROM Access Control: EAC will enable the EEPROM read/write sequence if EAC = 1. The EAS will be reset to " 0 " if the read/write sequence finished. Set EAC = 0 will abort the EEPROM read/write sequence immediately.

The read/write sequence for EEPROM is described as following two statements.

Write Sequence:

```
write(ECR with ERWS=1 and EAC=1); /* enable the write sequence */
write(BFR, address); /* specify the address in which the data will be modified */
write(BFR, word_data); /* specify the data which will be write into the EEPROM */
repeat( read(ECR.EAC); ) until (EAC=0); /* wait for the programming process completed */
```

File2

Any operation that violate the write sequence will cause the EEPROM programming process aborted. The BFR is a buffer register located at the register address of page3, 04H of LCE. With the EEPROM load back sequence specified above, the contents at the specified address will be overwritten by the new data. One word of data is modified by each write sequence. The allowable address in which the content will be modified is from 00H to 3fH.

Read Sequence:

```
write(ECR with ERWS=0 and EAC=1); /* enable the read sequence */
write(BFR, address); /* specify the address in which the data will be read out */
repeat( read(ECR.EAC); ) until (EAC=0); /* wait for the reading process completed */
read(BFR); /* read word data */
```



The read data will be kept in the BFR after the reading process is completed. The content of BFR will not be changed except that the other write or read sequence is started or a write(BFR, address) operation is executed. i.e. the data of BFR can be read out any time afterwards.

EEPROM Content

The format of EEPROM contents is as follows:

ADDRESS	HIGH BYTE	LOW BYTE
	Bit 15 ~ Bit 8	Bit 7 ~ Bit 0
0FH	Reserved	Reserved
0EH	Reserved	Reserved
0DH	Reserved	Reserved
0CH	Reserved	Reserved
0BH	MCR	Revision I.D.
0AH	Device I.D.(high byte)	Device I.D.(low byte)
09H	Vendor I.D.(high byte)	Vendor I.D.(low byte)
08H	MAX_LAT	MIN_GNT
07H	57H	57H
06H	Reserved	Reserved
05H	Reserved	Reserved
04H	Reserved	Reserved
03H	Reserved	Reserved
02H	Ethernet Address 5	Ethernet Address 4
01H	Ethernet Address 3	Ethernet Address 2
00H	Ethernet Address 1	Ethernet Address 0

The 5757H located at 07H address is used for NE2000 compatibility. The ELANC-PCI will load this parameter into its internal register file for NE2000 software compatibility.

EEPROM Load Timing

A system reset should allow at least 1usec for the W89C940 to decode the action as a reset. After reset signal, the device start to read the EEPROM after 1usec. The read clock is sent by the W89C940 to the EEPROM. Normally the period of the clock is 1.2usec. It will take about 14.4usec to read the 12 bytes of data from EEPROM.

The reset timing is as shown below.

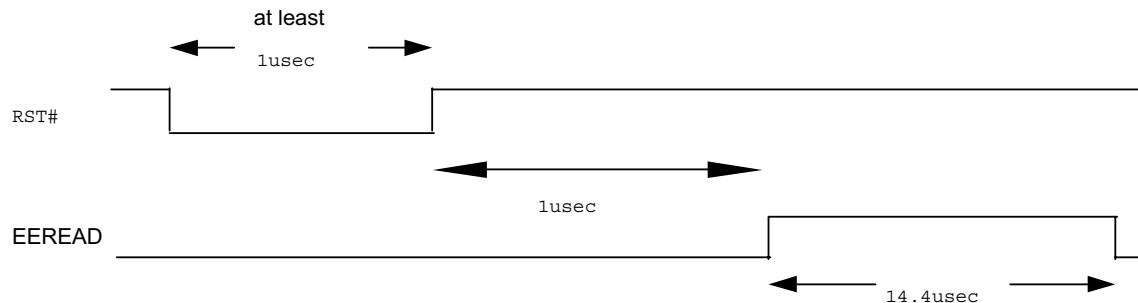

Since the ELANC-PCI reloads data into the configuration registers each time the system is reset, caution should be taken in handling resets. A system reset should keep low at least 480ns for the ELANC-PCI to decode the action as a reset. Any signal on the RESET pin shorter than this will be interpreted as noise and no response will be taken by the ELANC-PCI.

After the reset signal is recognized, the ELANC-PCI to read configurations and ID contents from the EEPROM. The read clock is sent by the ELANC-PCI to the EEPROM. Normally the period of the clock is 1.2 μ S. The ELANC-PCI will serially generate the EEPROM address so that the configuration and ID

After the reset signal is recognized, the ELANC-PCI to read configurations and ID contents from the EEPROM. The read clock is sent by the ELANC-PCI to the EEPROM. Normally the period of the clock is 1.2 μ S. The ELANC-PCI will serially generate the EEPROM address so that the configuration and ID will be read into the internal register file of W89C940.

NETWORK STATUS LED DISPLAY FUNCTION

Network Segment Status LED Display

Network activity displaying. ACT will indicate the network activity status by three types of signals (DC0 DC1 and AC 10Hz).

DC 0 : indicating "Link Good", if UTP is selected.

DC 1 : indicating 1) "Link fail", if UTP is selected.

2) "idle", if AUI is selected.

AC 10Hz : indicating the DTE is transmitting a packet or the carrier on the network is detected by the transceiver and the carrier sense signal is received by W89C940.

The ACT will keep DC 1 if there is an abnormal network collision occurred, e.g. the transceiver collision signal always active.

UTP OR COAXIAL AUTO-SELECTION FUNCTION

Auto Media-Switching

The ELANC-PCI provides a UTP/BNC auto media-switching function. The physical interface will jump from UTP to BNC when the ELANC-PCI is configured as UTP, link checking is enabled, and the current UTP path is broken. It will jump back immediately after the UTP path has been reconnected. When the physical interface is configured as BNC or AUI, this auto media-switching function will be disabled.



PHY1	PHY0	LNKEN	GDLNK	Auto Switching Function
0	0	1	1	disabled, keep at UTP
0	0	0	1	enabled, keep at UTP
0	0	0	0	enabled, UTP switch to BNC or AUI
0	1	1	1	disabled, keep at AUI
0	1	0	0 or 1	disabled, keep at AUI
1	0	1	1	disabled, keep at AUI
1	0	0	0 or 1	disabled, keep at AUI
1	1	1	1	disabled, keep at UTP
1	1	0	1	enabled, keep at UTP
1	1	0	0	enabled, UTP switch to BNC or AUI

SIGNATURE REGISTER

The signature register can be read by PCI Configuration Cycle with address 40H. The consecutive read will get a data pattern 88H, 00H, 88H, 00H,.... if byte enable (C_BEB#) is asserted. A write operation will have no effect on the content of this signature register.

Early Interrupt Function

1. Background:

W89C940 includes some control circuit and status register bits to generate interrupt signal early during receiving packets. Besides traditional interrupt generated at incoming packet end, W89C940 can generate interrupt when received packet bytes reach Early Interrupt Threshold and early interrupt function is enabled.

2. Register List:

Registers	IO Address	Descriptions
EIR_EN	Page 0 Base+0bh [0]	Early Interrupt Enable Register: Read/Write Asserted high to enable Early Interrupt Function. Deasserted to disable Early Interrupt Function. To program Receive Control Register (RCR) to monitor mode or Data Configuration Register (DCR) to Loopback mode will also disable Early Interrupt Function. Initial value after Power-on Reset is 0. Read once write.
EIR_MASK	Page 0 Base+0bh [1]	Early Interrupt Mask Register: Read/Write Asserted high to initiate an interrupt on INTA# of PCI local bus when an Early Interrupt Event occurred. Deasserted this register will mask an interrupt generated. Deasserted this register does not disable Early Interrupt Status Register. Initial value after Power-on Reset is 0. Read once write.
EIR_STATUS	Page 0 Base+0bh [7]	Early Interrupt Status Register: Read/Write Asserted high when the byte count of incoming frame reaches Early Interrupt Threshold with correct destination address (DS), in the enable mode of Early Interrupt Function. Write 1 to clear EIR_STATUS. Initial value after Power-on Reset is 0. Read once write.



EIR_THD [15:0]	Page 3 Base+06h [15:0]	Early Interrupt Threshold Register: Word Read/Write Early Interrupt Threshold is in the unit of byte. The minimum value of threshold is 64 bytes. Any value less than 64 bytes will be treated as 64 bytes except value 0000h. Not to program threshold or program 0000h will be disable Early Interrupt function. The initial threshold value after Power-on Reset is 0000h.
CLDA0[7:0] CLDA1[7:0]	Page 0 Base+01h[7:0] Base+02h[7:0]	Current Local DMA Address Register: Read only. Current Address of Local DMA. Use word IO read command to access the content. Initial value after Power-on Reset is 0000h. Using word command to read port base+01h will have both CLDA0 & CLDA1.

3. Program Procedure:

- a. Set EIR_EN=1 to enable Early Interrupt Function and set EIR_MASK=1 to enable interrupt pin INTA# of PCI local bus.
- b. Program early interrupt threshold, EIR_THD.
- c. Set DCR not in Loopback mode.
- d. Set RCR not in monitor mode.
- e. Program CR to start receive packet.
- f. Wait until a frame with a correct destination address and receive byte count greater than Early interrupt Threshold.
- g. An interrupt initiated and EIR_STATUS register set.

ps: a, b, c, d & e can also be programmed individually.

PCI BUS TRANSACTION

This section will introduce the Read Transaction, Write Transaction, and Termination Transaction of PCI bus.

Read Transaction (I/O and Memory Read)

The timing of read transaction is shown in figure.

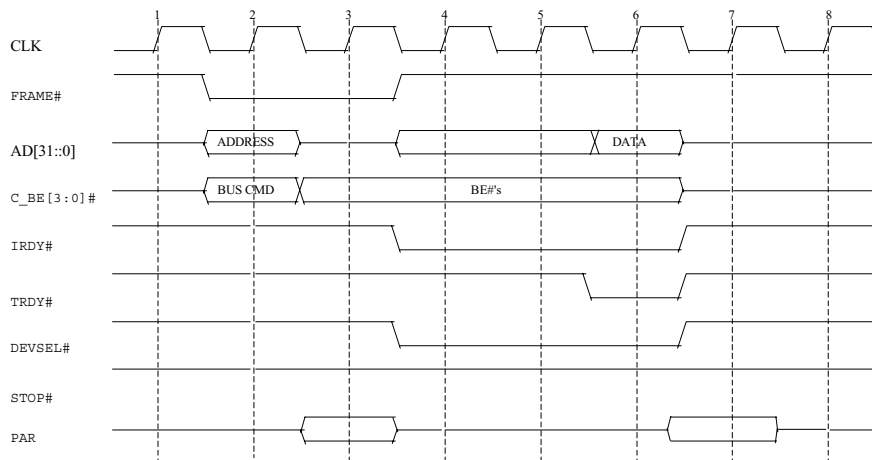

The transaction is initiated by FRAME# , the address is asserted and bus read command of C/BE[3:0]# is also asserted. This phase is called address phase. IRDY# (Initiator Ready) is asserted by master after address phase. Target initiate TRDY#(Target Ready) and assert valid data on the bus. The DEVSEL# means the target is addressed and respond to the master device. The data transaction is happened on both IRDY# and TRDY# are asserted on the same clock edge that is called data phase. During the data phase, the BE (Byte Enable) indicate the data length of the data. If it is a double word, 32 bits, the BE will be 0000. If data is a word, the BE will be 1100 or 0011

If the host send the memory read command in burst mode, W89C940 accept the first data phase access and then reject the further data access request with retry disconnection. Only one data phase is allowed for transaction.

Write Transaction (I/O and Memory Write)

The write transaction is like read transaction, the FRAME# initiate the transaction with address phase and the data is written in data phase. The data could be asserted directly after address phase. It does not need a WAIT state for avoiding bus contention. The transaction is ended when the FRAME#, IRDY#, TRDY# and DEVSEL# are deasserted. If the host send the memory read command in burst mode, W89C940 accept the first data phase access and then reject the further data access request with Retry disconnection. Only one data phase is allowed for transaction.

The write transaction is as shown in the figure

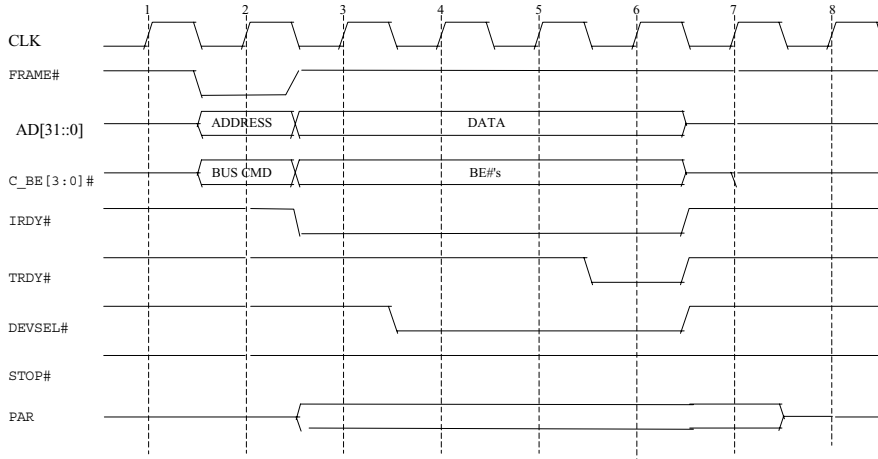

Configuration Read Transaction

The Configuration Read timing is as shown

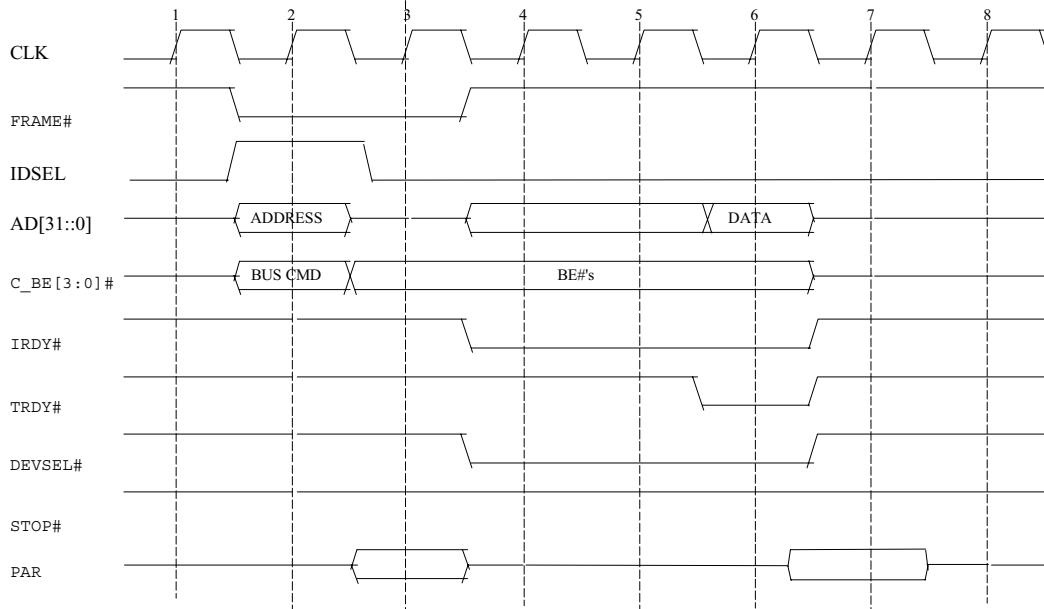

The timing is the same as the figure I/O Read Transaction, except the IDSEL is asserted during the address phase. The transaction access the configuration registers of the device.

Configuration Write Transaction

The timing is as shown.

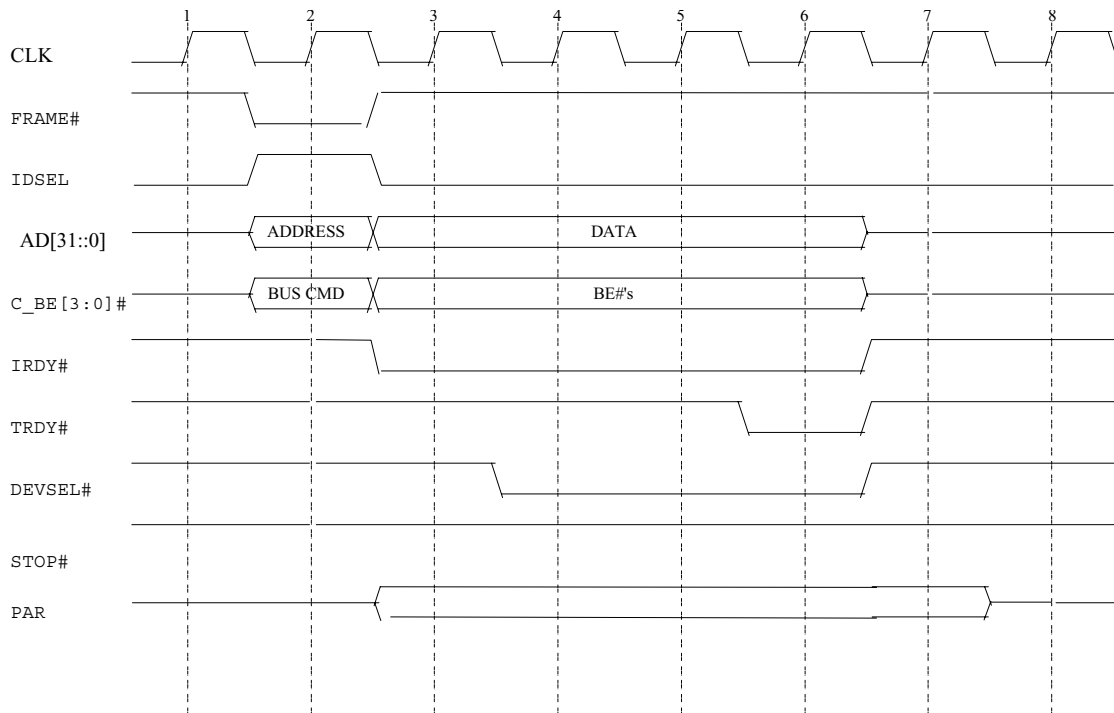

The timing is the same as the figure I/O Read Transaction, except the IDSEL is asserted during the address phase. The transaction access the configuration registers of the device.

Transaction Termination

Target Initiated Termination

The W89C940 device can only work in slave mode. It respond to the request from the master device and act as a target. Sometimes the target are unable to answer the master device and initiate a termination. There are two types of termination will occur. The first one is disconnect-C/Retry type. The second one is Target Abort type. The timing is as shown in the figure

The first type is the Disconnect-C/Retry type, as shown in the figure

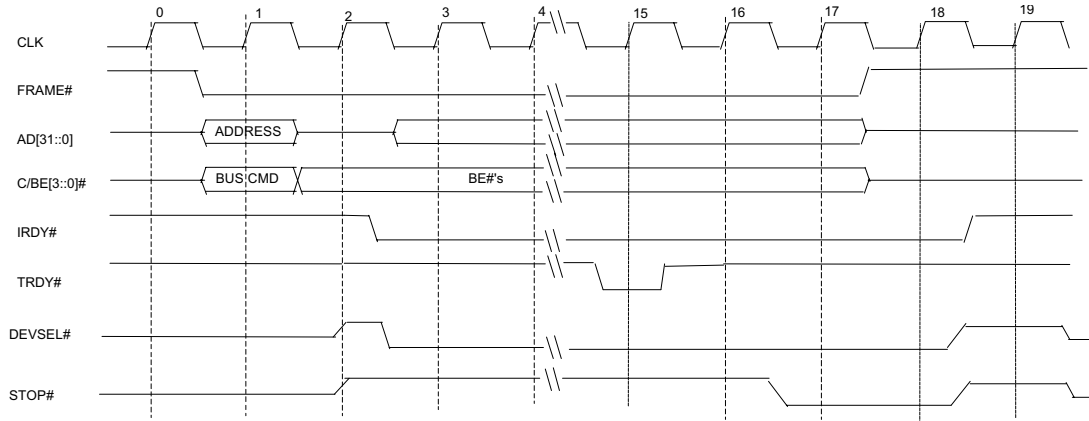

Because W89C940 don't support memory command in burst mode. When the host try to send memory command in burst mode, the first data phase is completed. TRDY# and IRDY# are deasserted, but the FRAME# is asserted for the next data phase. The device will assert STOP# to terminate the transaction. Data is not transferred after STOP# is asserted. The host need to initiate another transaction for further data transfer. The timing is shown above.

The Target-Abort type, as shown in the figure

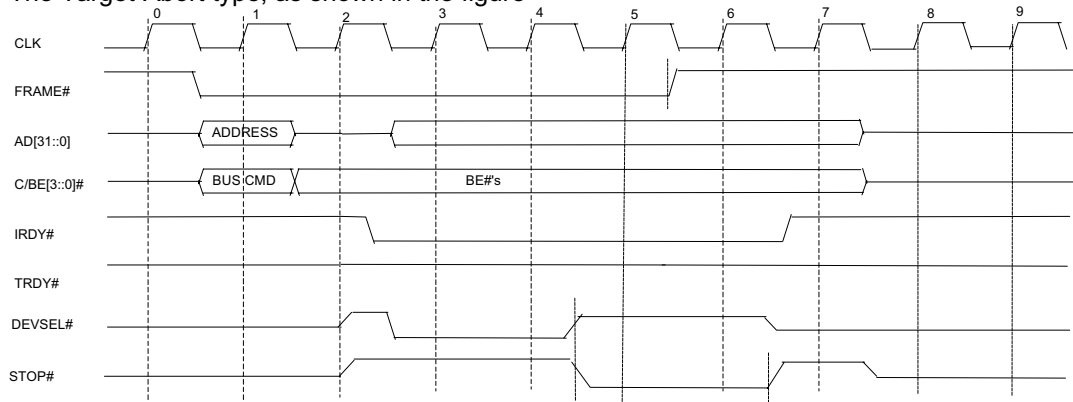

The condition is the target requires the transaction to be terminated and does not want the transaction tried again. As shown in the figure, the DEVSEL# is deasserted when STOP# is asserted. If there is a data needed to be transferred, DEVSEL# must be asserted for one or more clock cycles and TRDY# must be deasserted before target-abort can be signaled.

There are two cases that the device will initiate the target-abort. The first one is the addressing parity check error cause internal SERR# asserted and the second one is the Byte Enable and addressing check error. If addressing don't match the following table, the target doesn't transfer the data, but terminate with target abort.

AD1	AD0	C/BE3#	C/BE2#	C/BE1#	C/BE0#
0	0	X	X	X	0
0	1	X	X	0	1
1	0	X	0	1	1

W89C940



1	1	0	1	1	1
---	---	---	---	---	---



Fast Back-to-Back Transactions

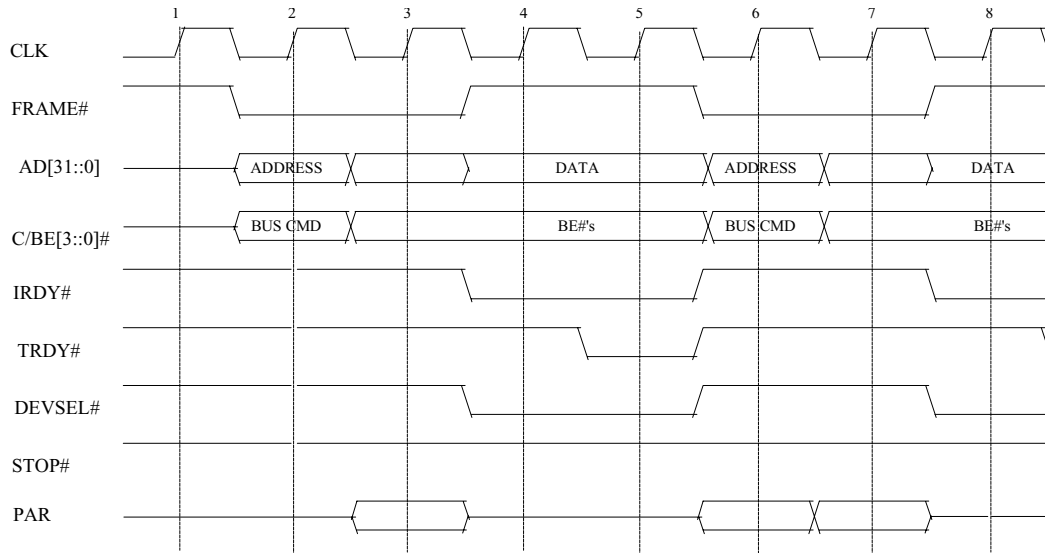

Without contention of TRDY#, DEVSEL#, or STOP#, the IDLE states between transactions are removed. It increase the throughput of the data transaction. If the first transaction is a write cycle and the second transaction access(can be read or write transaction) to the same target , one IDLE cycle can be removed between transactions.

Parity

As shown in the figure below, parity is generated at immediately following clock and the internal PERR# is after PAR. Parity is calculated the same on all PCI transactions regardless of the type or form. Parity covers AD[31:0] and C/BEB[3:0]# lines regardless of whether or not all lines carry meaningful information. The number of 1s on AD[31:0], C/BEB[3:0]# and PAR equals an even number. Parity is also calculated at Configuration phase.

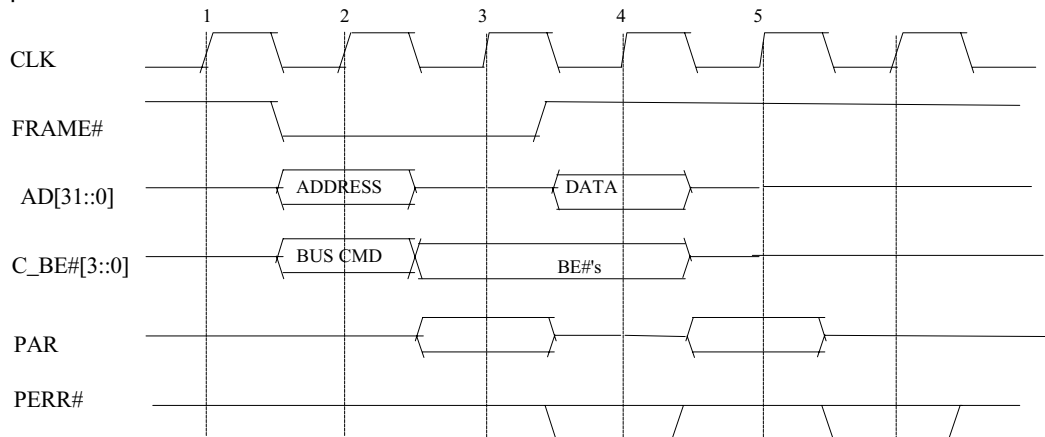



TEST MODE SETTING AND DEFINITION

W89C940 provide three test modes they are 90 test mode, TP test mode, and AUI test mode. The system reset signal is fed into 400ns low glitch eater and the output is RST_I. At 400 nsec RST_I asserted period, the three pins (EECS,BPCSB,RCSB) output (0,1,1). After RST_I deasserted, the three pins become input pins and sample at 90nsec. The sampled value (*1,*2,*3) determine the test mode. The timing and test mode type is shown as following.



EECS_O	0	Z	Z	Z	0
BPCS_O	1	Z	Z	Z	1
RCSB_O	1	Z	Z	Z	1
EECS_I	Z	Z	*1	Z	Z
BPCSB_I	Z	z	*2	Z	Z
RCSB_I	Z	z	*3	z	Z

- EECS_O: EECS pin output driver
 EECS_I : EECS pin input forcing
 (*1, *2, *3) = (0,1,1) ---- normal operation mode
 = (1,0,0) ---- fast EEPROM mode
 = (1,0,1) ---- 90 test mode
 = (1,1,0) ---- TP test mode
 = (1,1,1) ---- AUI test mode
 = (0,0,0) ---- AUI linear mode

FILE 3



ABSOLUTE MAXIMUM RATINGS

SYMBOL	PARAMETER	MINIMUM	MAXIMUM	UNIT
TA	Operating Temperature	0	70	°C
TS	Storage Temperature	-55	150	°C
V _{DD}	Supply Voltage	-0.5	7.0	V
V _{IN}	Input Voltage	V _{SS} -0.5	V _{DD} +0.5	V
V _{OUT}	Output Voltage	V _{SS} -0.5	V _{DD} +0.5	V
TL	Lead Temperature (Soldering 10 seconds maximum)		250	°C

POWER SUPPLY (V_{DD}=4.75 V TO 5.25V, V_{SS}=0 V, TA=0 °C TO 70 °C)

SYMBOL	PARAMETER	CONDITION	MINIMUM	MAXIMUM	UNIT
IDDI	Power Supply Current(idle, clock active)	V _{dd} =5.25V		150	mA
IDDT	Power Supply Current(transmitting)	V _{dd} =5.25V		250	mA

DC CHARACTERISTICS (V_{DD}=4.75 V TO 5.25 V, V_{SS}=0 V, TA=0 °C TO 70 °C)

DIGITAL:

SYMBOL	PARAMETER	CONDITION	MINIMUM	MAXIMUM	UNIT
V _{IL}	Low Level Input Voltage		V _{SS} -0.5	0.8	V
V _{IH}	High Level Input Voltage		2.0	V _{DD} +0.5	V
V _{OL}	Low Output Voltage	I _{oL} =4.0mA		0.4	v
V _{OH}	High Output Voltage	I _{oh} =-4.0mA	2.4		v
I _{IL1}	Input Leakage Current (Note 1)	V _{in} =5.25V V _{in} =0V		10	μA
I _{IL2}	Input Leakage Current (Note 2)	V _{in} =5.25V V _{in} =0V		2	mA

W89C940



I_{OL}	Tristate leakage Current	$V_{out}=V_{dd}$		0.3	mA
		$V_{out}=V_{ss}$	-10		μA

Note 1: All of the input pins except those stated in Note 2.; Note 2: XRDP, XRDM, CDP, CDN, RXP, RXN.

AUI:

SYMBOL	PARAMETER	CONDITION	MINIMUM	MAXIMUM	UNIT
V_{DD}	Differential Output Voltage (TXP/N)	as the test load	+/-550	+/-1200	mV
V_{OB}	Differential Idle Output Voltage Imbalance (TXP/N)	as the test load		+/-40	mV
V_U	Undershoot Voltage (TXP/N)	as the test load		100	mV
V_{DS}	Differential Squelch Threshold (CDP/N, RXP/N)		-175	-300	mV
V_{CM}	Differential Input Common Mode Voltage (CDP/N, RXP/N)		2.0	4.0	V

TWISTED PAIR:

SYMBOL	PARAMETER	CONDITION	MINIMUM	MAXIMUM	UNIT
R_{TI}	XRDP/M Differential Input Resistance		3		Kohms
V_{TIB}	XRDP/M Open Circuit Input Voltage (bias)		-2.75	VDD-1.0	V
V_{TIV}	XRDP/M Differential Input Voltage Range	VDD=5V	-3.1	3.1	V
V_{TPS}	XRDP/M Positive Squelch Threshold		300	585	mV
V_{TNS}	XRDP/M Negative Squelch Threshold		-585	-300	mV
V_{TPU}	XRDP/M Positive Unsquelch Threshold		200	350	mV
V_{TNU}	XRDP/M Negative Unsquelch Threshold		-350	-200	mV
V_{TOH}	TPDP/M High Output Voltage	I=32mA	VDDTP-.44	VDDTP	V

W89C940



V_{TOL}	TPDP/M Low Output Voltage	$I=32mA$	VSSTP	VSSTP+.44	V
I_{TO}	TPDP/M Output Current			32	mA
R_{TO}	TPDP/M Output Resistance			13.5	Kohms



PRELIMINARY SWITCHING CHARACTERISTICS

PCI Accesses

Read Transaction

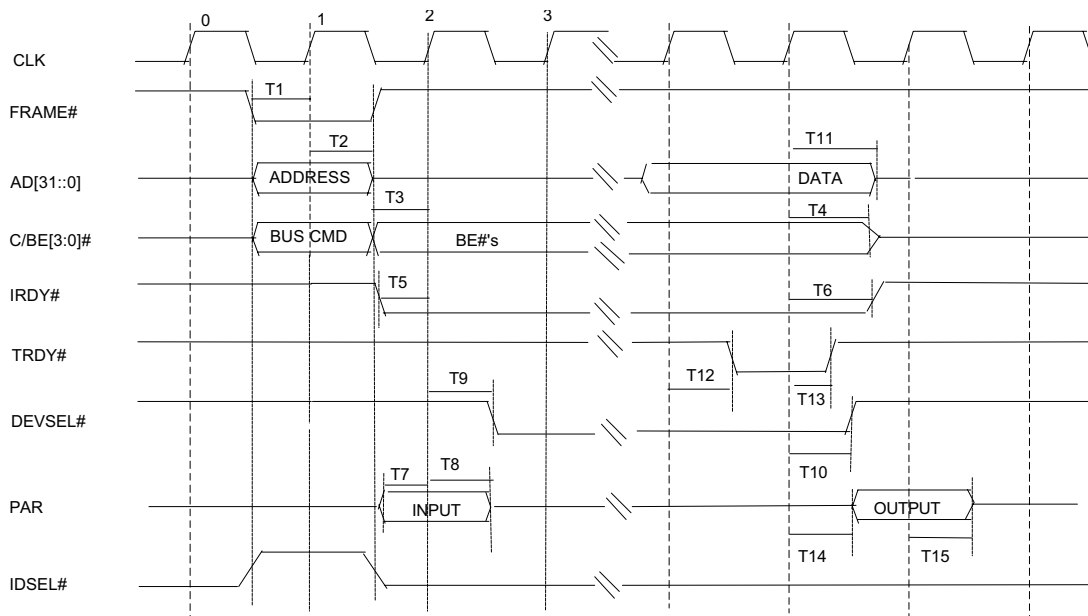

SYMBOL	DESCRIPTION	MIN	TYPICAL	MAX	UNIT
T1	PCI input signal set up time*	7			nsec
T2	PCI input signal hold time*	0			nsec
T3	BE Byte Enable set up time	7			nsec
T4	BE Byte Enable hold time	0			nsec
T5	IRDY# set up time	7			nsec
T6	IRDY# hold time	0			nsec
T7	PAR input setup time	7			nsec
T8	PAR input hold time	0			nsec
T9	DEVSEL# driven time	11	12	13	nsec
T10	DEVSEL# hold time	11	12	13	nsec
T11	output data hold time	18	19	20	nsec
T12	TRDY# driven time	11	12	13	nsec
T13	TRDY# hold time	11	12	13	nsec
T14	PAR output driven time	11	12	13	nsec
T15	PAR output hold time	11	12	13	nsec

*address, command, and FRAME# for slave access, IDSEL# for configuration read transaction



Write Transaction

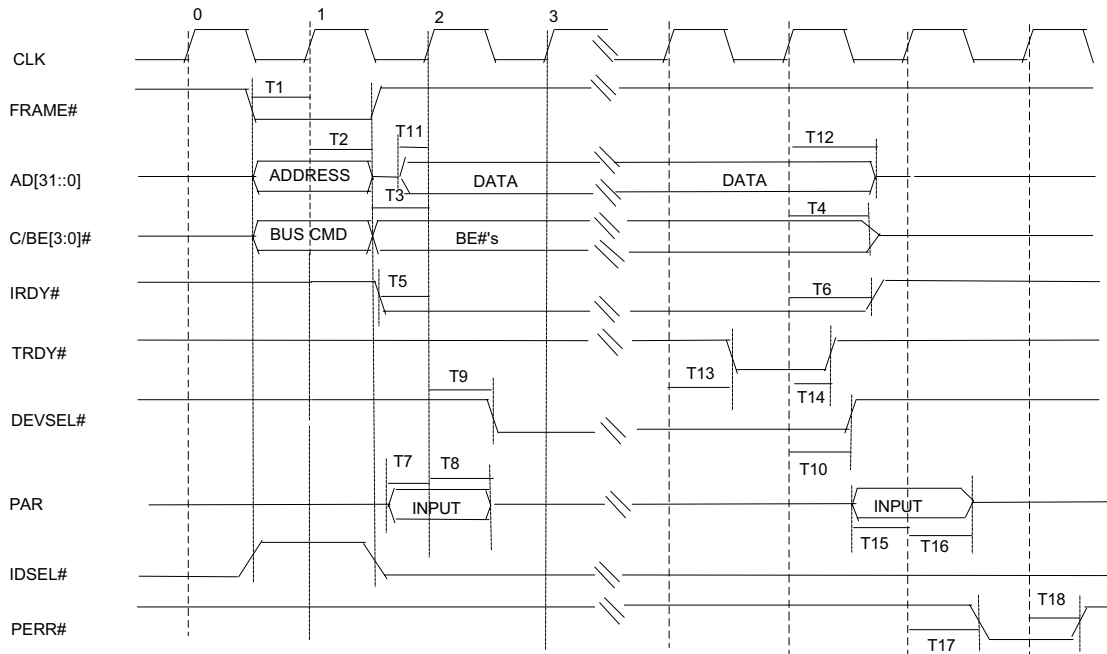

SYMBOL	DESCRIPTION	MIN	TYPICAL	MAX	UNIT
T1	PCI input signal setup time*	7			nsec
T2	PCI input signal hold time*	0			nsec
T3	BE Byte Enable set up time	7			nsec
T4	BE Byte Enable hold time	0			nsec
T5	IRDY# set up time	7			nsec
T6	IRDY# hold time	0			nsec
T7	PAR input setup time	7			nsec
T8	PAR input hold time	0			nsec
T9	DEVSEL# driven time	11	12	13	nsec
T10	DEVSEL# hold time	11	12	13	nsec
T11	input data set up time	7			nsec
T12	input data hold time	0			nsec
T13	TRDY# driven time	11	12	13	nsec
T14	TRDY# hold time	11	12	13	nsec
T15	PAR input setup time	7			nsec
T16	PAR input hold time	0			nsec
T17	Internal PERR# driven time**	11	12	13	nsec
T18	Internal PERR# hold time**	11	12	13	nsec

*address, command, and FRAME# for slave access, IDSEL# for configuration read transaction

**Internal PERR# will be asserted if the parity error event occurred.



Transaction Termination

Disconnect-C/Retry Type

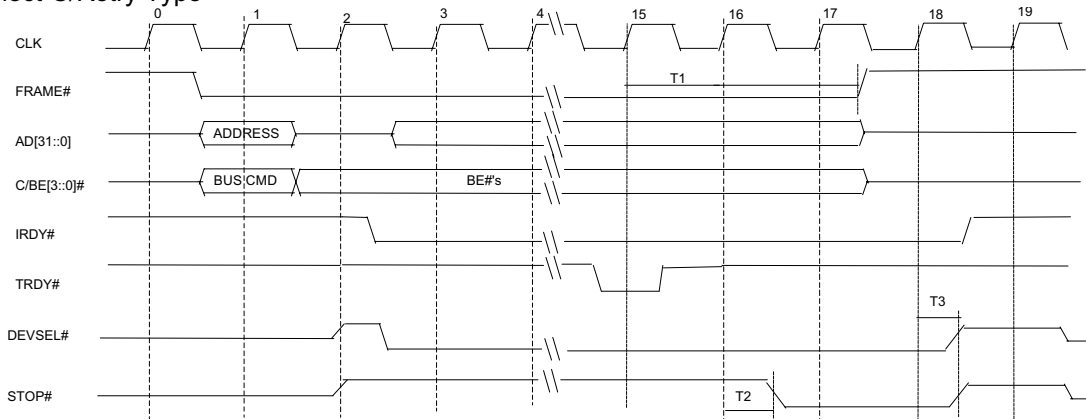

SYMBOL	DESCRIPTION	MIN	TYP	MAX	UNIT
T1	FRAME# deasserted from clock 15	0			nsec
T2	Clock 16 to STOP# asserted time	11	12	13	nsec
T3	Clock 18 to STOP# and DEVSEL# hold time	11	12	13	nsec

Note: 1) The other timing requirements for PCI input signal are as the read transaction timing.
 2) T1, T2 and T3 are used for the disconnect type C (host try to transfer more than one data phase).

Target-Abort Type

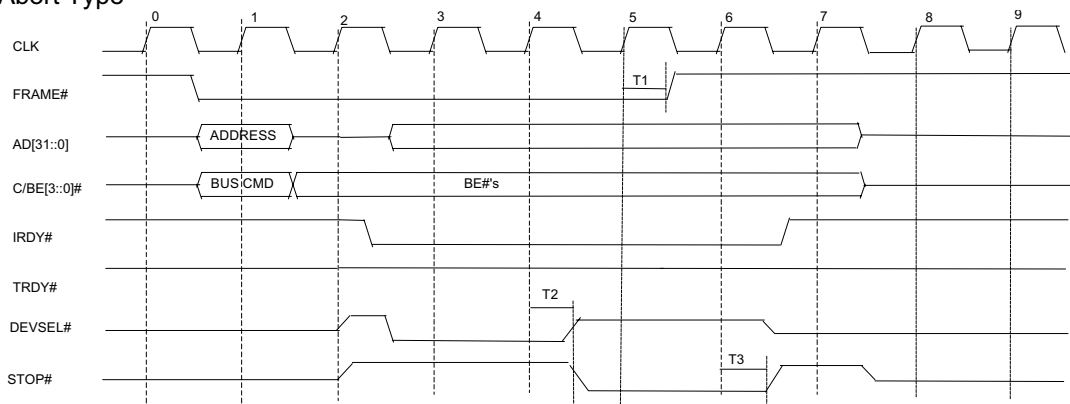

SYMBOL	DESCRIPTION	MIN	TYP	MAX	UNIT
T1	FRAME# deasserted from clock 15	0			nsec
T2	Clock 4 to DEVSEL# hold time	11	12	13	nsec
T3	Clock 6 to STOP# hold time	11	12	13	nsec

Note: 1) The other timing requirements for PCI input signal are as the read transaction timing..
 2) T2 and T3 are used for the target abort type (host addressing error).

Fast Back-to-Back Transactions

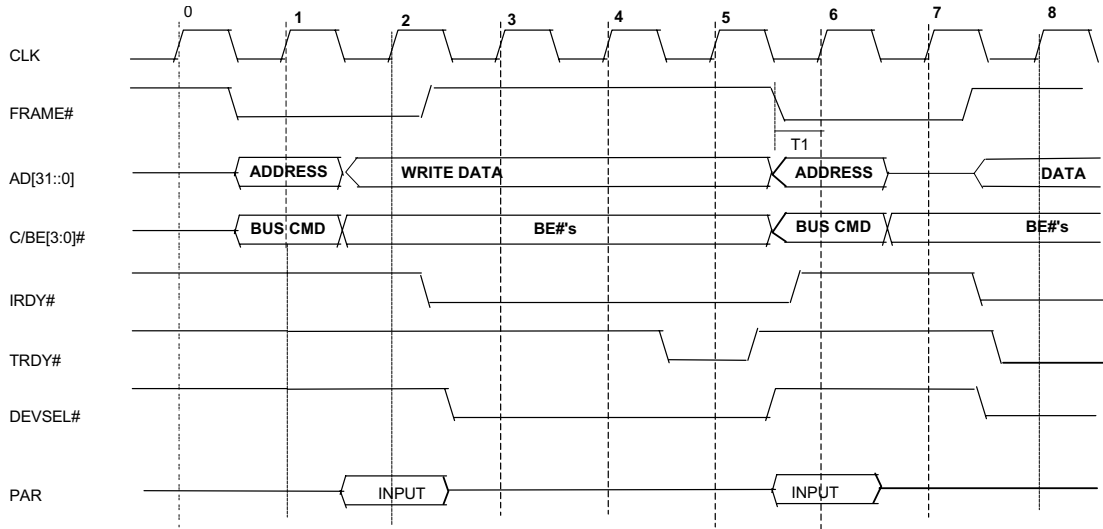

SYMBOL	DESCRIPTION	MIN	TYPICAL	MAX	UNIT
T1	FRAME# set up time to clock 6	7			nsec



MEMORY SUPPORT BUS ACCESS

32KX8-20 SRAM

Remote Read Byte Access Cycle

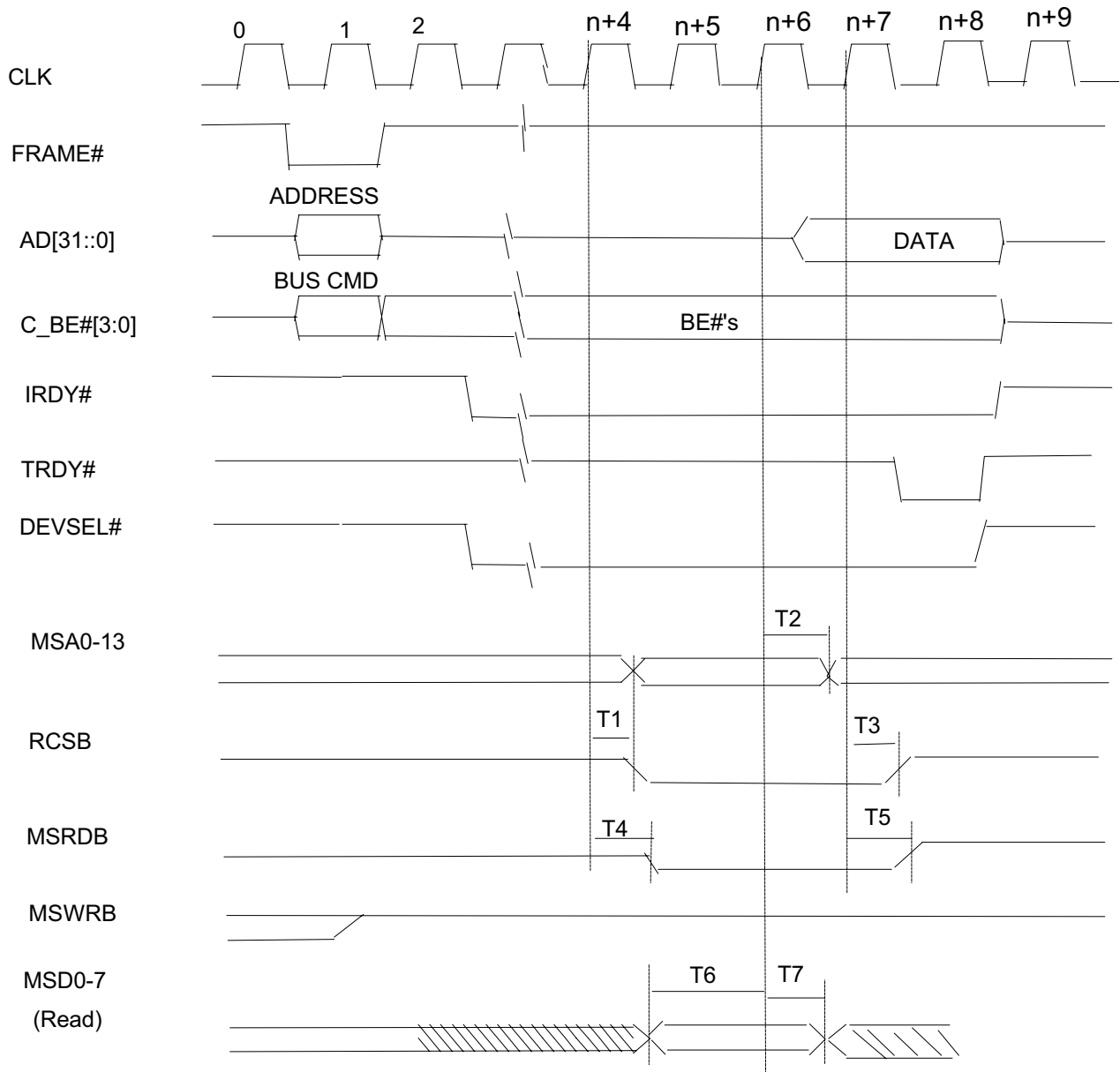

SYMBOL	DESCRIPTION	MIN	TYPICAL	MAX	UNIT
--------	-------------	-----	---------	-----	------



T1	clock n+4 to RCSB and MSA valid (note 2)	20	25	30	nsec
T2	clock n+6 to MSA valid	25	28	30	nsec
T3	clock n+7 to RCSB deasserted time	10	15	20	nsec
T4	clock n+4 to MSRDB valid	22	27	30	nsec
T5	clock n+7 to MSRDB deasserted time	15	20	25	nsec
T6	MSD setup tim to clock n+6	7			nsec
T7	MSD hold time from clock n+6	0			nsec

Remote Read Word Access Cycle

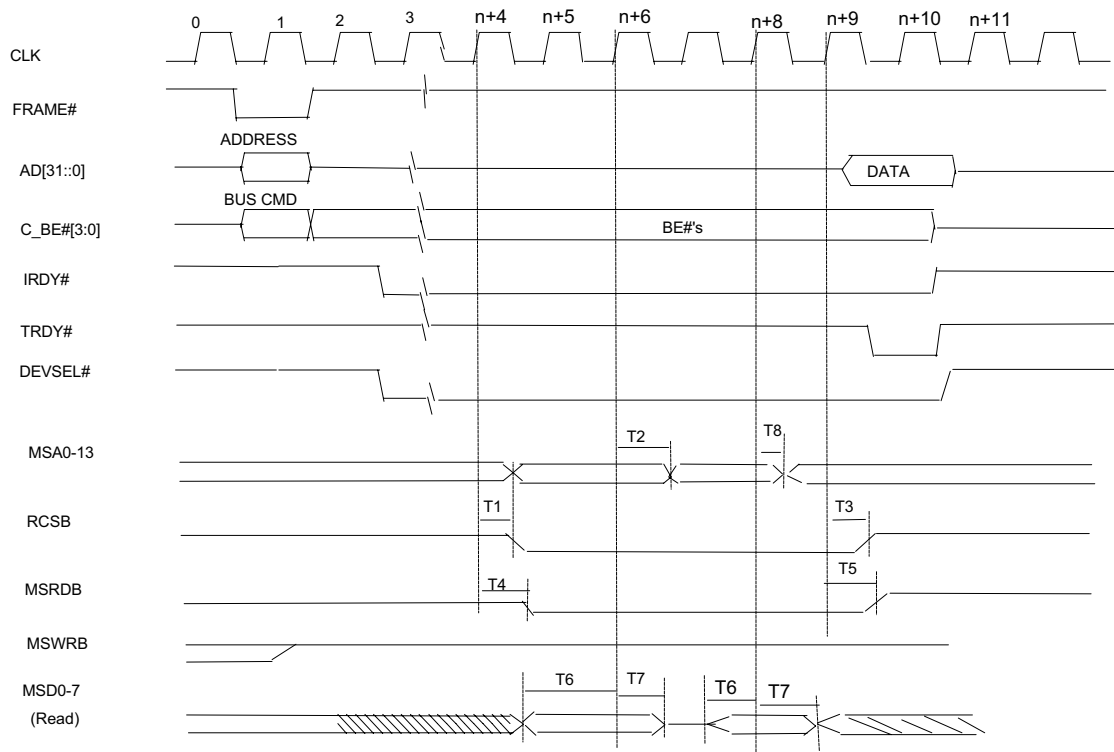

Note: 1) The other timing requirements for PCI signal are as the read transaction timing.
 2) n=0,1,2,3,..... when local DMA get the control of the bus, PCI bus will insert wait state.
 Wait state number is n.

SYMBOL	DESCRIPTION	MIN	TYPICAL	MAX	UNIT
T1	clock n+4 to RCSB and MSA valid (note 2)	20	25	30	nsec
T2	clock n+6 to MSA valid	25	28	30	nsec
T3	clock n+7 to RCSB deasserted time	10	15	20	nsec



T4	clock n+4 to MSRDB valid	22	27	30	nsec
T5	clock n+7 to MSRDB deasserted time	15	20	25	nsec
T6	MSD setup tim to clock n+6	7			nsec
T7	MSD hold time from clock n+6	0			nsec
T8	MSD hold time from clock n+8				nsec

Remote Read Double Word Access Cycle

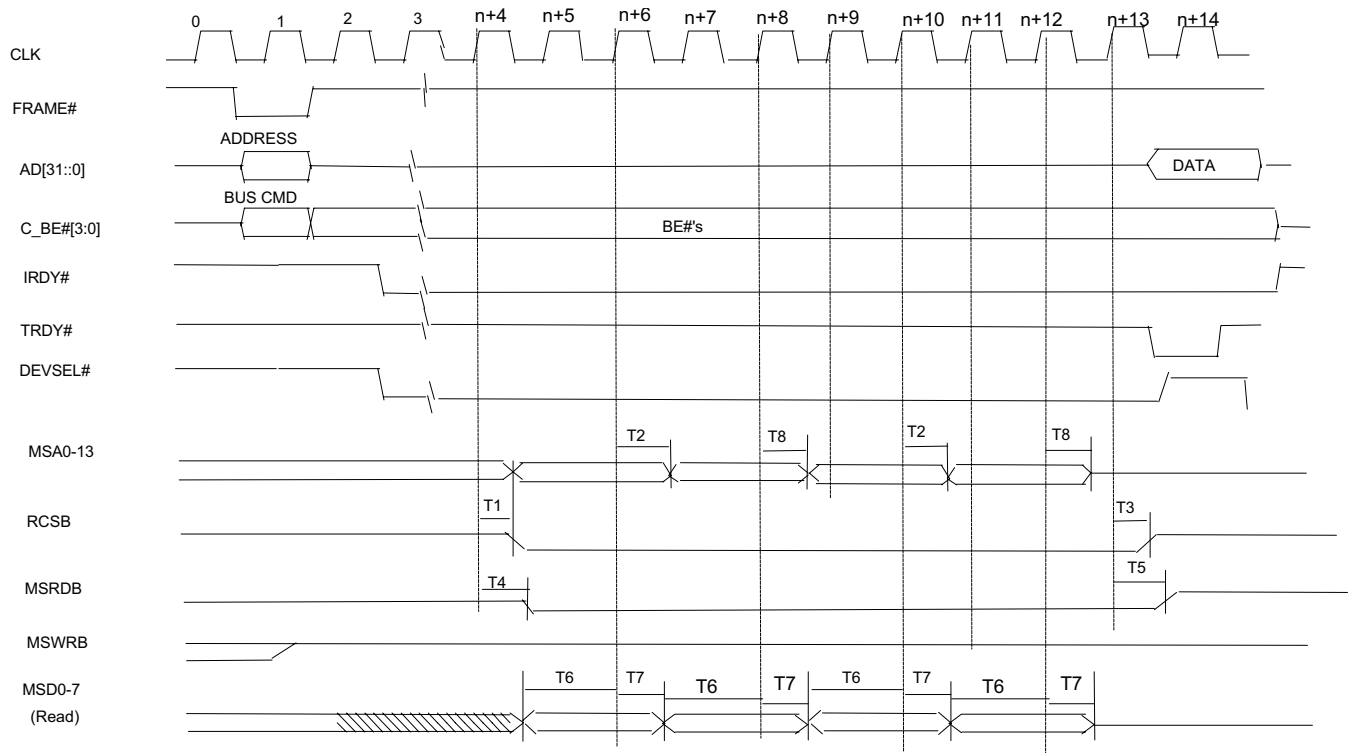

SYMBOL	DESCRIPTION	MIN	TYPICAL	MAX	UNIT
T1	clock n+4 to RCSB and MSA valid (note 2)	20	25	30	nsec
T2	clock n+6 to MSA valid	25	28	30	nsec
T3	clock n+7 to RCSB deasserted time	10	15	20	nsec
T4	clock n+4 to MSRDB valid	22	27	30	nsec
T5	clock n+7 to MSRDB deasserted time	15	20	25	nsec
T6	MSD setup tim to clock n+6	7			nsec
T7	MSD hold time from clock n+6	0			nsec
T8	MSD hold time from clock n+8				nsec

Remote Write Byte Access Cycle

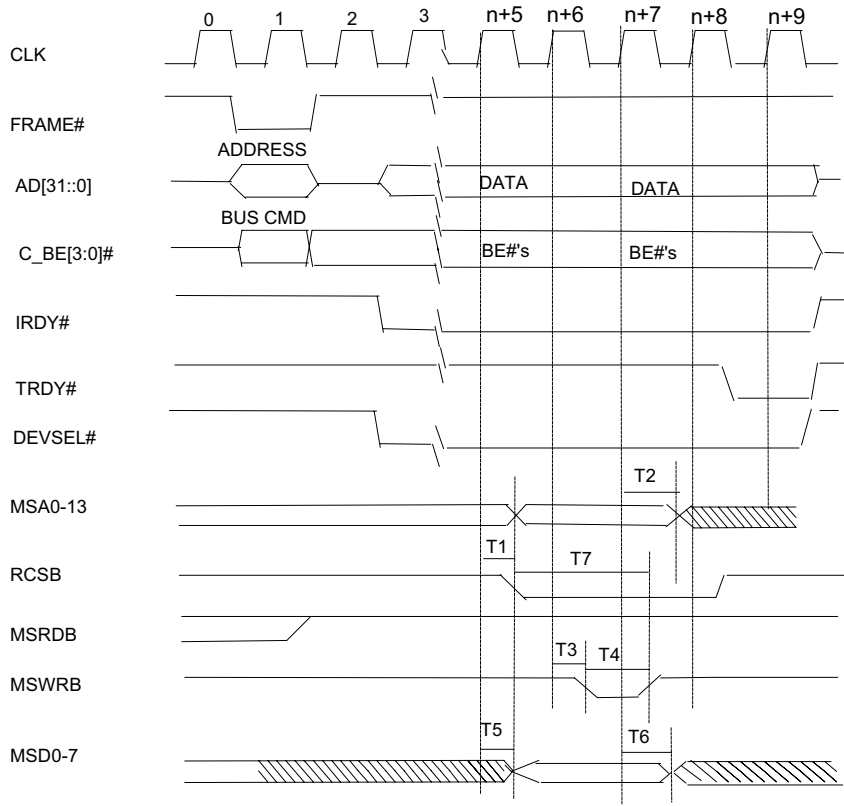

SYMBOL	DESCRIPTION	MIN	TYPICAL	MAX	UNIT
T1	Clock n+5 to MSA, RCSB, and MSD valid (note 2)	17	22	27	nsec
T2	clock n+7 to MSA valid	14	19	24	nsec
T3	clock n+6 to MSWRB valid	9	14	19	nsec
T4	Write pulse width	4	9	14	nsec
T5	clock n+5 to MSD valid	7	12	17	nsec
T6	clock n+7 to MSD deasserted	14	19	24	nsec
T7	MSA change to MSWRB deasserted time	17	22	27	nsec
T8	clock n+7/ n+9 to MSD deasserted	16	21	26	nsec
T9	clock n+9 to MSD deasserted	8	13	18	nsec

File4

Remote Write Word Access Cycle

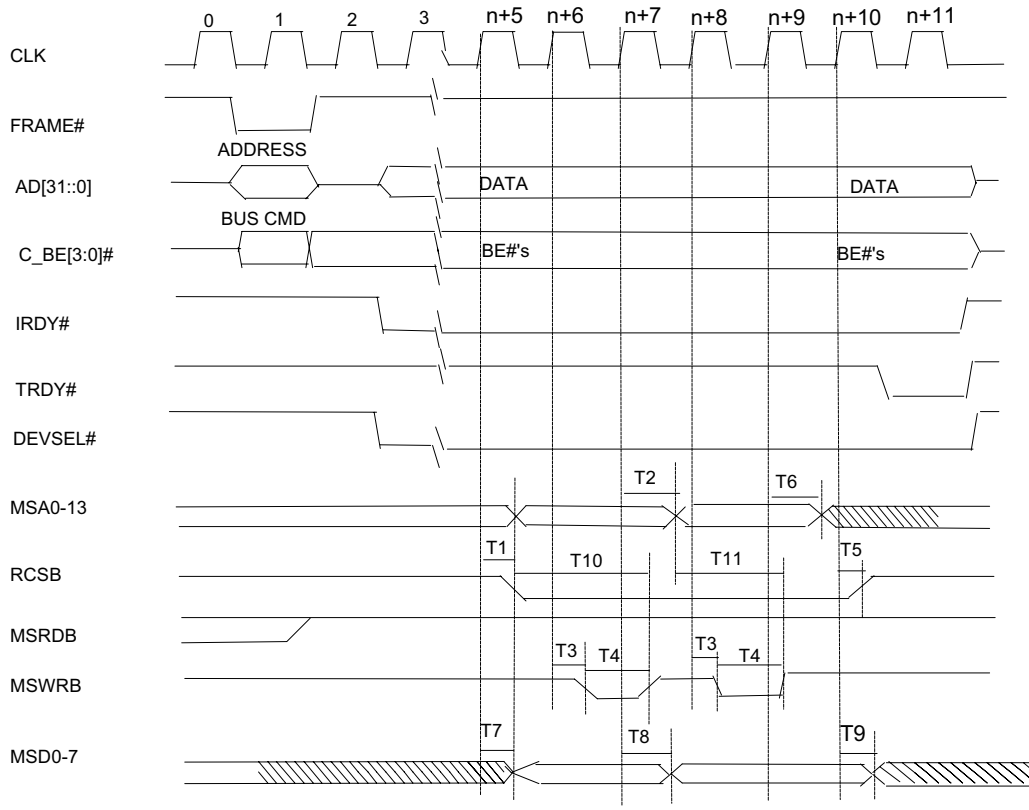

Note: 1) The other timing requirements for PCI signal are as the read transaction timing.
 2) $n=0,1,2,3,\dots$ when local DMA get the control of the bus, PCI bus will insert wait state.
 Wait state number is n .

SYMBOL	DESCRIPTION	MIN	TYPICAL	MAX	UNIT
T1	Clock $n+5$ to MSA, RCSB, and MSD valid (note 2)	17	22	27	nsec
T2	clock $n+7$ to MSA valid	14	19	24	nsec
T3	clock $n+6$ to MSWRB valid	9	14	19	nsec
T4	Write pulse width	4	9	14	nsec
T5	clock $n+10$ to RCSB deasserted	7	12	17	nsec
T6	clock $n+9$ to MSA deasserted	14	19	24	nsec
T7	clock $n+5$ to MSD valid	17	22	27	nsec
T8	clock $n+7$ to MSD deasserted	16	21	26	nsec
T9	clock $n+10$ to MSD deasserted	8	13	18	nsec
T10	MSA change to MSWRB deasserted time				
T11	MSA change to MSWRB deasserted time				



Remote Write Double Word Access Cycle

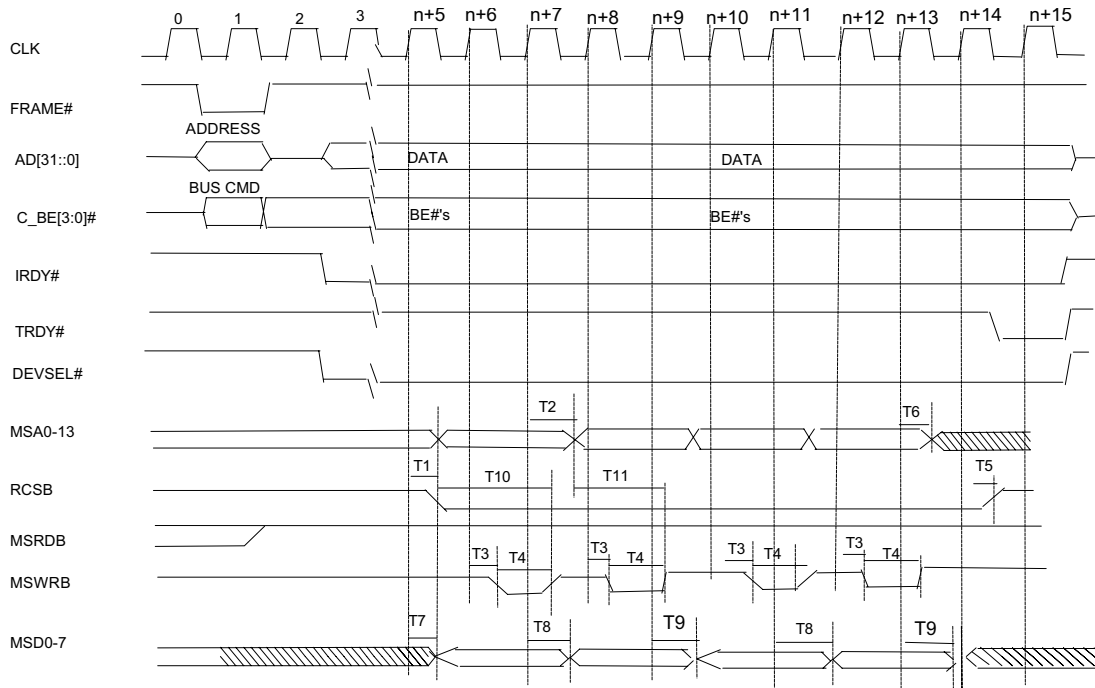

SYMBOL	DESCRIPTION	MIN	TYPICAL	MAX	UNIT
T1	Clock n+5 to MSA, RCSB, and MSD valid (note 2)	17	22	27	nsec
T2	clock n+7 to MSA valid	14	19	24	nsec
T3	clock n+6 to MSWRB valid	9	14	19	nsec
T4	Write pulse width	4	9	14	nsec
T5	clock n+11 to RCSB deasserted	7	12	17	nsec
T6	clock n+10 to MSA deasserted	14	19	24	nsec
T7	clock n+5 to MSD valid	17	22	27	nsec
T8	clock n+7 to MSD deasserted	16	21	26	nsec
T9	clock n+9 to MSD deasserted	8	13	18	nsec
T10	MSA change to MSWRB deasserted time				
T11	MSA change to MSWRB deasserted time				

32KX8-70 SRAM

Remote Read Byte Access Cycle

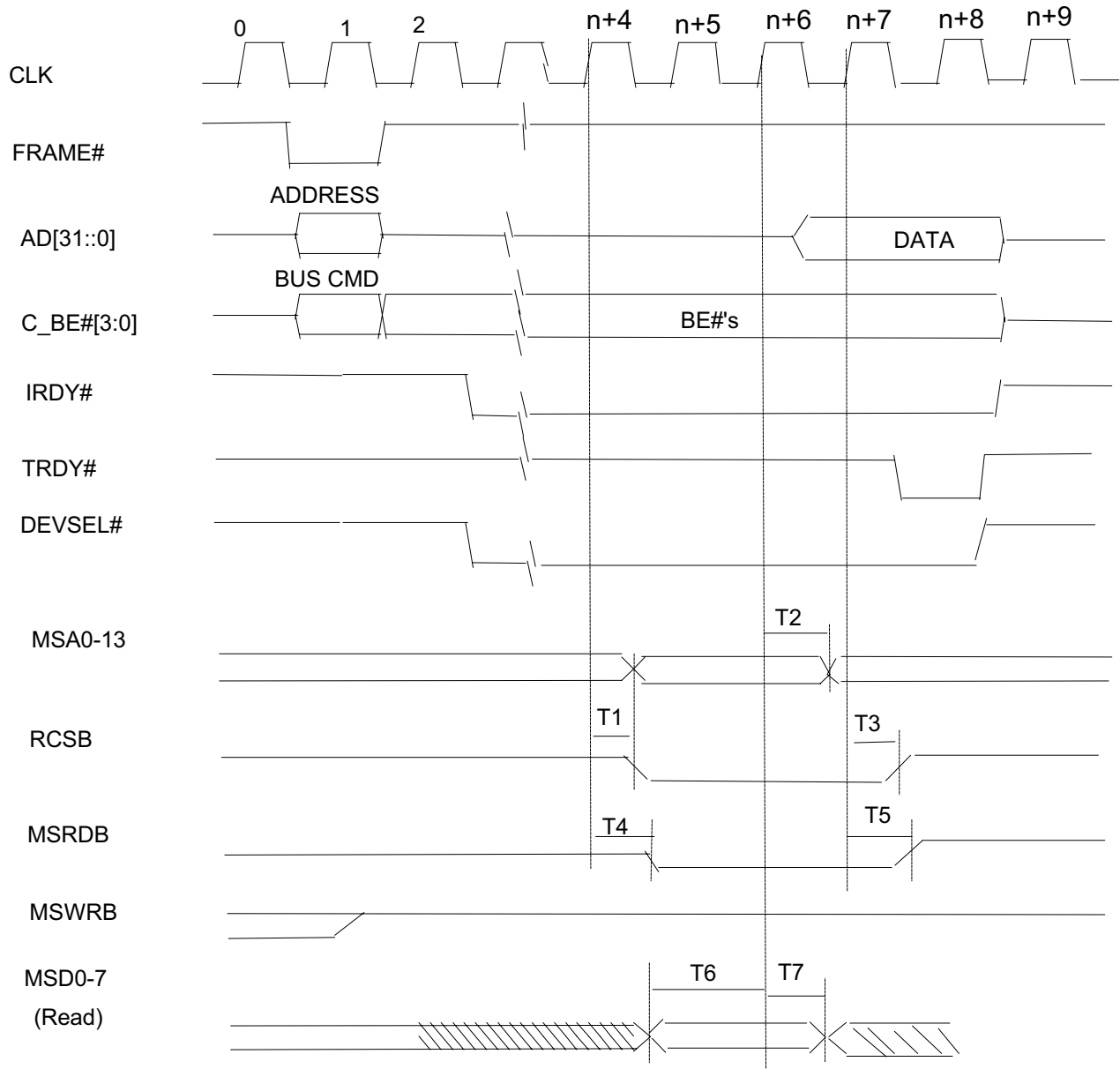

SYMBOL	DESCRIPTION	MIN	TYPICAL	MAX	UNIT
T1	clock n+4 to RCSB and MSA valid (note 2)	20	25	30	nsec



T2	clock n+6 to MSA valid	25	28	30	nsec
T3	clock n+7 to RCSB deasserted time	10	15	20	nsec
T4	clock n+4 to MSRDB valid	22	27	30	nsec
T5	clock n+7 to MSRDB deasserted time	15	20	25	nsec
T6	MSD setup tim to clock n+6	7			nsec
T7	MSD hold time from clock n+6	0			nsec

Remote Read Word Access Cycle

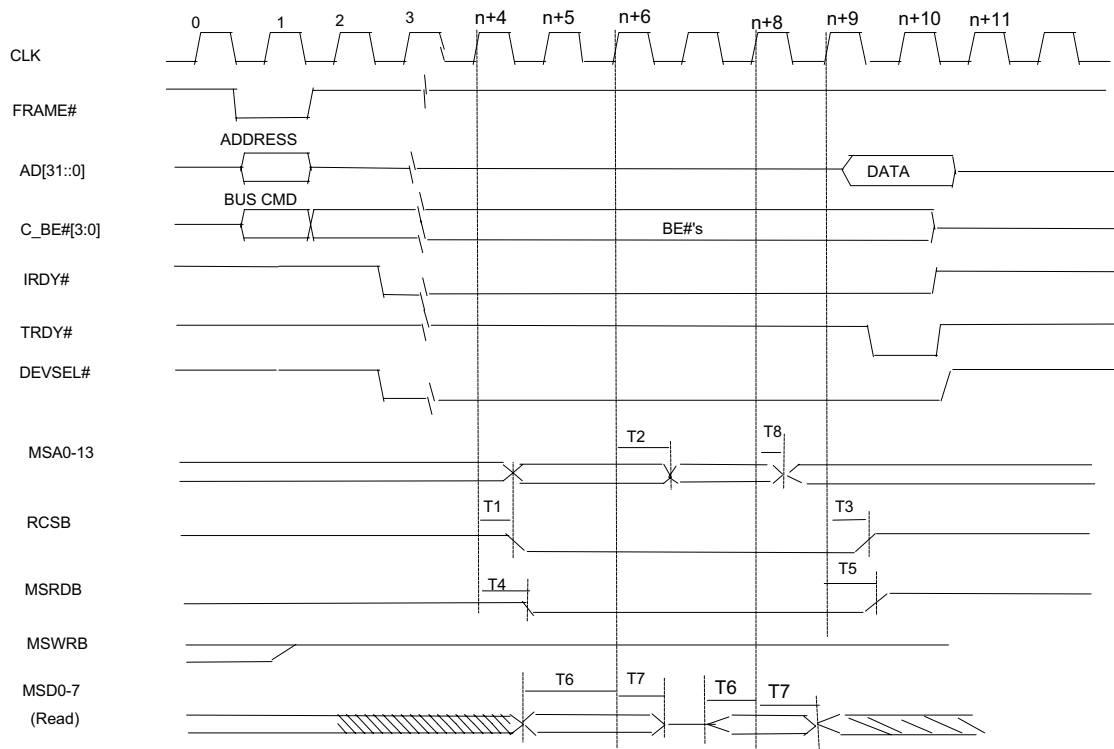

Note: 1) The other timing requirements for PCI signal are as the read transaction timing.
 2) n=0,1,2,3,..... when local DMA get the control of the bus, PCI bus will insert wait state. Wait state number is n.

SYMBOL	DESCRIPTION	MIN	TYPICAL	MAX	UNIT
T1	clock n+4 to RCSB and MSA valid (note 2)	20	25	30	nsec
T2	clock n+6 to MSA valid	25	28	30	nsec
T3	clock n+7 to RCSB deasserted time	10	15	20	nsec
T4	clock n+4 to MSRDB valid	22	27	30	nsec
T5	clock n+7 to MSRDB deasserted time	15	20	25	nsec



T6	MSD setup tim to clock n+6	7			nsec
T7	MSD hold time from clock n+6	0			nsec
T8	MSD hold time from clock n+8				nsec

Remote Read Double Word Access Cycle

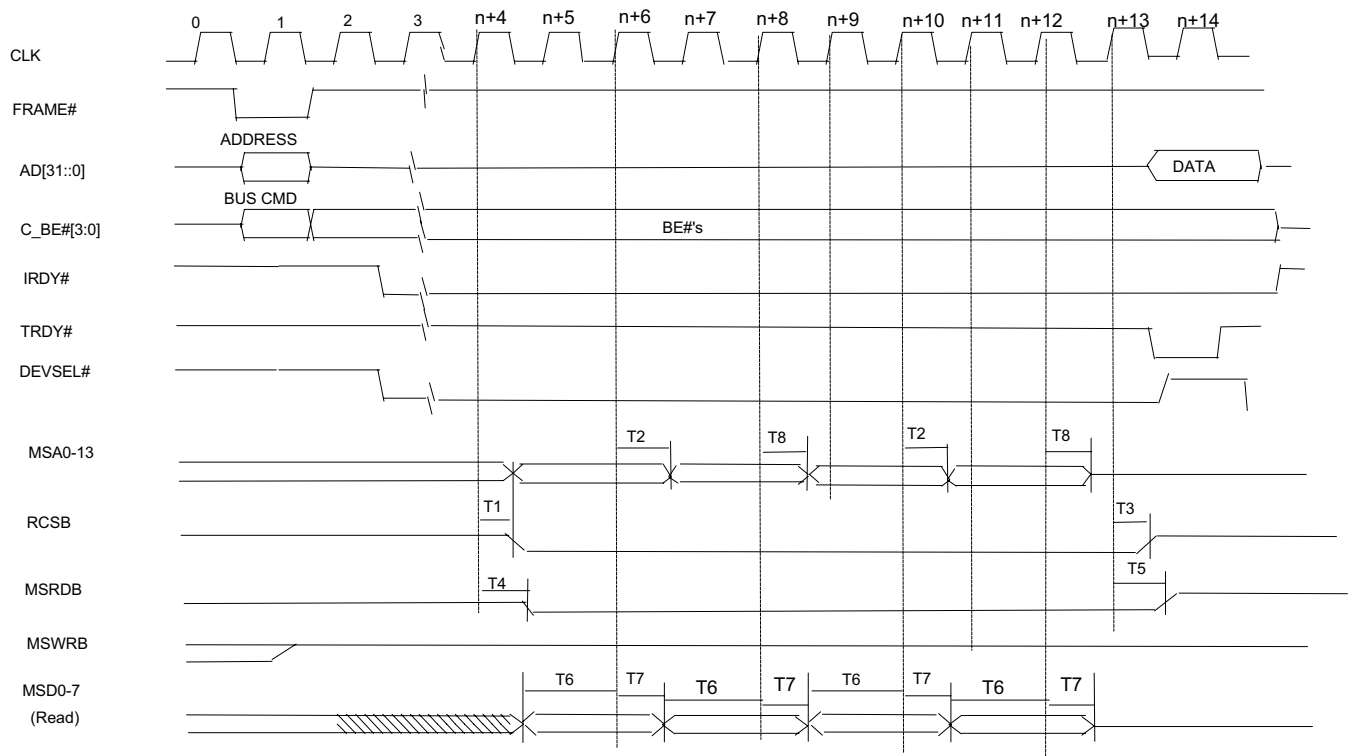

SYMBOL	DESCRIPTION	MIN	TYPICAL	MAX	UNIT
T1	clock n+4 to RCSB and MSA valid (note 2)	20	25	30	nsec
T2	clock n+6 to MSA valid	25	28	30	nsec
T3	clock n+7 to RCSB deasserted time	10	15	20	nsec
T4	clock n+4 to MSRDB valid	22	27	30	nsec
T5	clock n+7 to MSRDB deasserted time	15	20	25	nsec
T6	MSD setup tim to clock n+6	7			nsec
T7	MSD hold time from clock n+6	0			nsec
T8	MSD hold time from clock n+8				nsec

Remote Write Byte Access Cycle

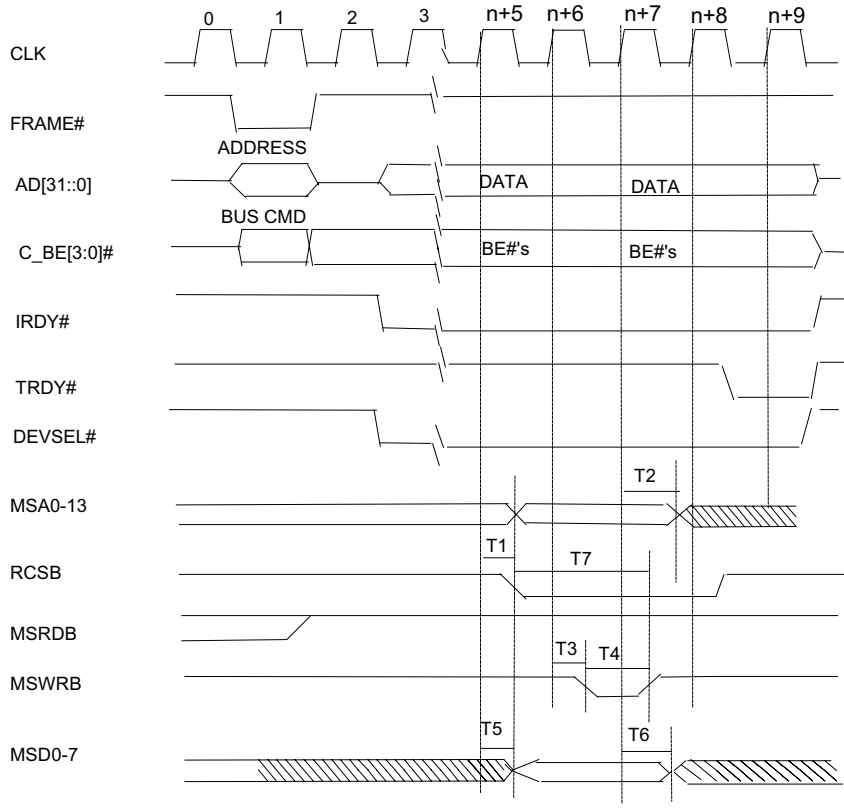

SYMBOL	DESCRIPTION	MIN	TYPICAL	MAX	UNIT
T1	Clock n+5 to MSA, RCSB, and MSD valid (note 2)	17	22	27	nsec
T2	clock n+7 to MSA valid	14	19	24	nsec
T3	clock n+6 to MSWRB valid	9	14	19	nsec
T4	Write pulse width	4	9	14	nsec
T5	clock n+5 to MSD valid	7	12	17	nsec
T6	clock n+7 to MSD deasserted	14	19	24	nsec
T7	MSA change to MSWRB deasserted time	17	22	27	nsec
T8	clock n+7/ n+9 to MSD deasserted	16	21	26	nsec
T9	clock n+9 to MSD deasserted	8	13	18	nsec

Remote Write Word Access Cycle

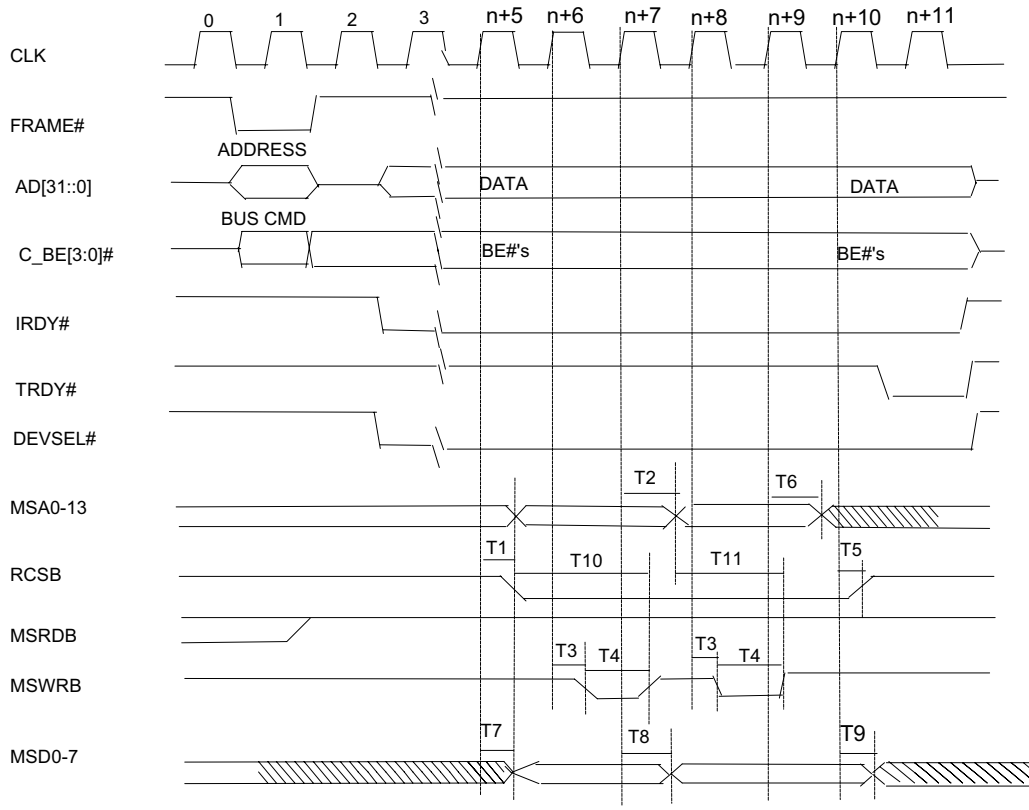

Note: 1) The other timing requirements for PCI signal are as the read transaction timing.
 2) $n=0,1,2,3,\dots$ when local DMA get the control of the bus, PCI bus will insert wait state.
 Wait state number is n .

SYMBOL	DESCRIPTION	MIN	TYPICAL	MAX	UNIT
T1	Clock $n+5$ to MSA, RCSB, and MSD valid (note 2)	17	22	27	nsec
T2	clock $n+7$ to MSA valid	14	19	24	nsec
T3	clock $n+6$ to MSWRB valid	9	14	19	nsec
T4	Write pulse width	4	9	14	nsec
T5	clock $n+10$ to RCSB deasserted	7	12	17	nsec
T6	clock $n+9$ to MSA deasserted	14	19	24	nsec
T7	clock $n+5$ to MSD valid	17	22	27	nsec
T8	clock $n+7$ to MSD deasserted	16	21	26	nsec
T9	clock $n+10$ to MSD deasserted	8	13	18	nsec
T10	MSA change to MSWRB deasserted time				
T11	MSA change to MSWRB deasserted time				



Remote Write Double Word Access Cycle

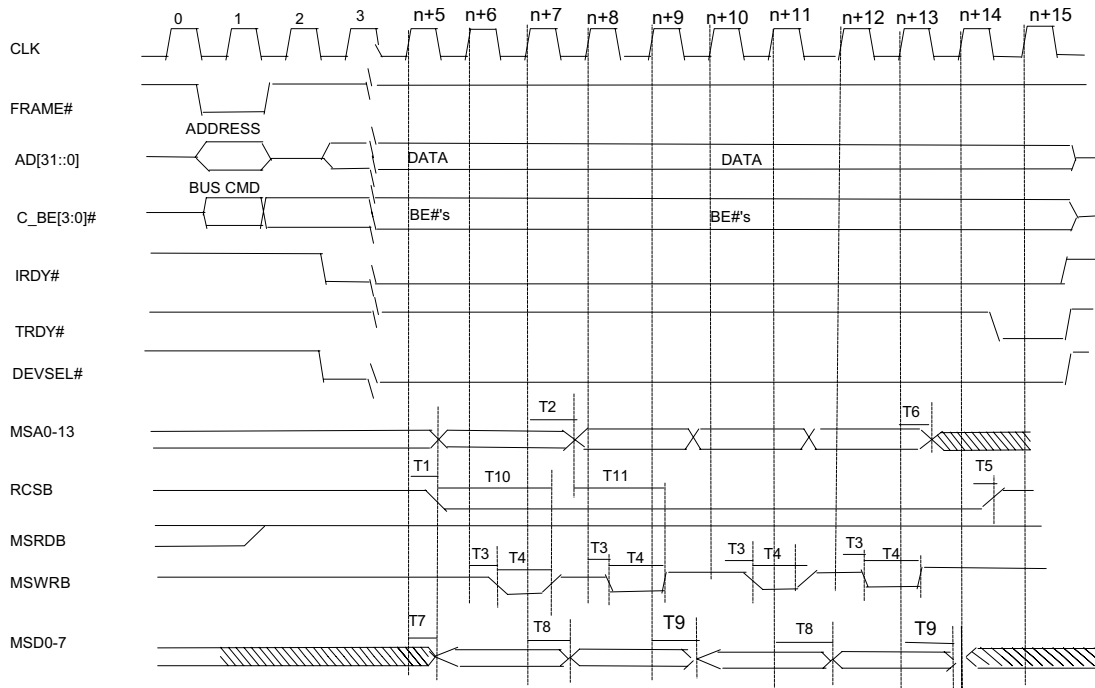

SYMBOL	DESCRIPTION	MIN	TYPICAL	MAX	UNIT
T1	Clock n+5 to MSA, RCSB, and MSD valid (note 2)	17	22	27	nsec
T2	clock n+7 to MSA valid	14	19	24	nsec
T3	clock n+6 to MSWRB valid	9	14	19	nsec
T4	Write pulse width	4	9	14	nsec
T5	clock n+11 to RCSB deasserted	7	12	17	nsec
T6	clock n+10 to MSA deasserted	14	19	24	nsec
T7	clock n+5 to MSD valid	17	22	27	nsec
T8	clock n+7 to MSD deasserted	16	21	26	nsec
T9	clock n+9 to MSD deasserted	8	13	18	nsec
T10	MSA change to MSWRB deasserted time				
T11	MSA change to MSWRB deasserted time				



Local Read cycle

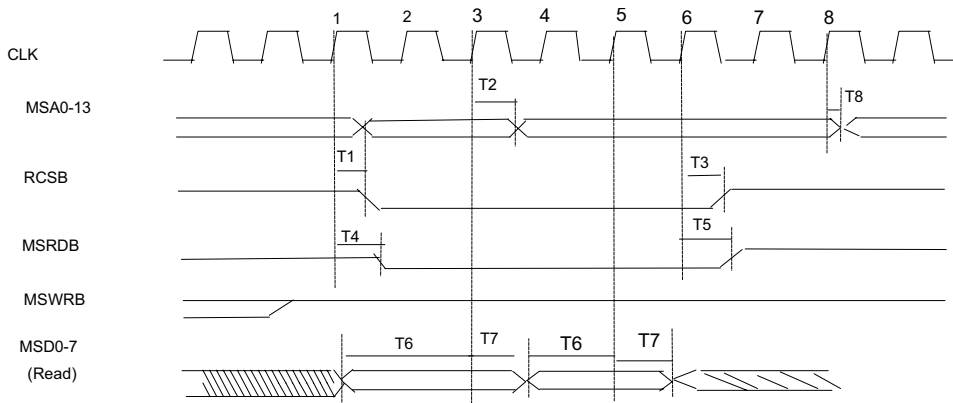

SYMBOL	DESCRIPTION	MIN	TYPICAL	MAX
T1	clock 1 to RCSB and MSA valid (note 2)	4	8	12
T2	clock 3 to MSA valid	20	24	28
T3	clock 6 to RCSB deasserted time	4	8	12
T4	clock 1 to MSRDB valid	8	12	16
T5	clock 6 to MSRDB deasserted time	8	12	16
T6	MSD setup time to clock 3	24	28	32
T7	MSD hold time from clock 3	24	28	32
T8	MSD hold time from clock 8			

Local Write cycle

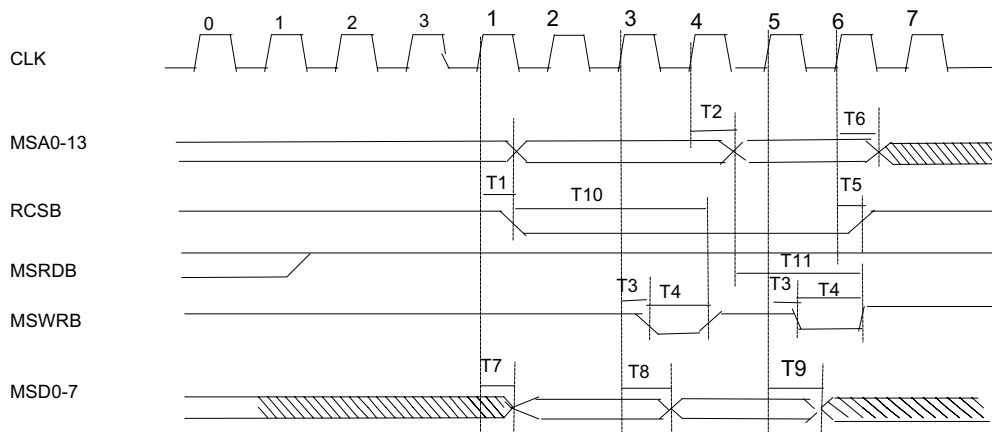

SYMBOL	DESCRIPTION	MIN	TYPICAL	MAX
--------	-------------	-----	---------	-----



T1	Clock 1 to MSA and RCSB valid	16	20	24
T2	clock 4 to MSA valid	4	8	12
T3	clock 3 to MSWRB valid	4	8	12
T4	Write pulse width	20	24	28
T5	clock 6 to RCSB deasserted	20	24	28
T6	clock 6 to MSA deasserted			
T7	clock 1 to MSD valid			
T8	clock 3 to MSD deasserted	8	12	16
T9	clock 5 to MSD deasserted	8	12	16
T10	MSA valid to MSWRB deasserted	64	68	72
T11	MSA valid to MSWRB deasserted	40	44	48



32KX8-220 BPROM/ FLASH MEMORY

Read cycle

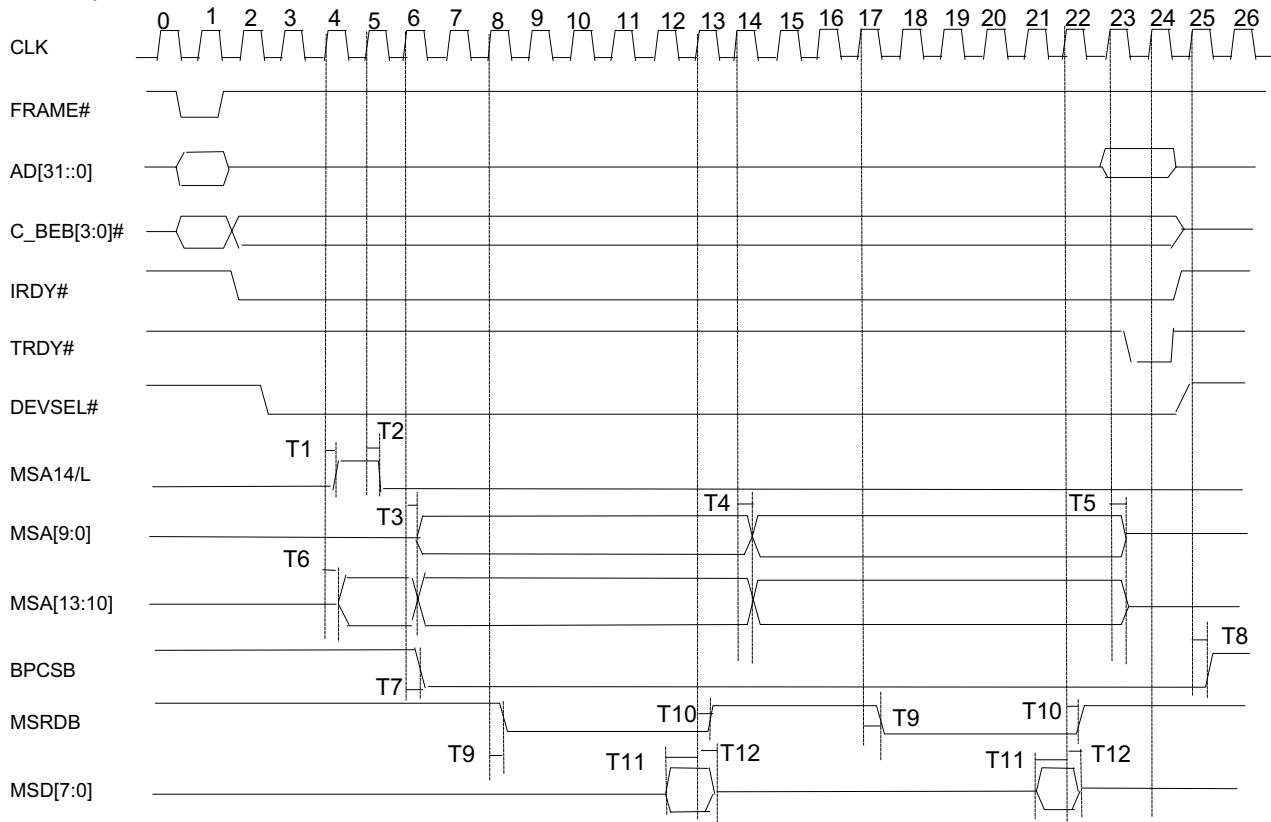

SYMBOL	DESCRIPTION	MIN	TYPICAL	MAX	UNIT
T1	clock 4 to MSA14/L valid	8	13	18	nsec
T2	clock 5 to MSA14/L deasserted time	8	13	18	nsec
T3	clock 6 to MSA bus valid	8	13	18	nsec
T4	clock 14 to MSA bus valid	8	13	18	nsec
T5	clock 23 to MSA deasserted	8	13	18	nsec
T6	clock 4 to MSA high nibble valid	8	13	18	nsec
T7	clock 6 to BPCSB valid	15	20	25	nsec
T8	clock 25 to BPCSB deasserted	7	12	17	nsec
T9	clock 8/ clock 17 to MSRDB asserted time	15	20	25	nsec
T10	clock 13/ clock 22 to MSRDB deasserted time	8	13	18	nsec
T11	MSD setup time from clock 13	7			nsec
T12	MSD hold time from clock 15	0			nsec

Note: 1) The other timing requirements for PCI signal are as the read transaction timing.
 2) BPROM/FLASH memory access could be byte, word or double word access.
 The timing is the same.

W89C940



FILE5



AUI/UTP TIMING

AUI Transmit Timing (End of Transmit)

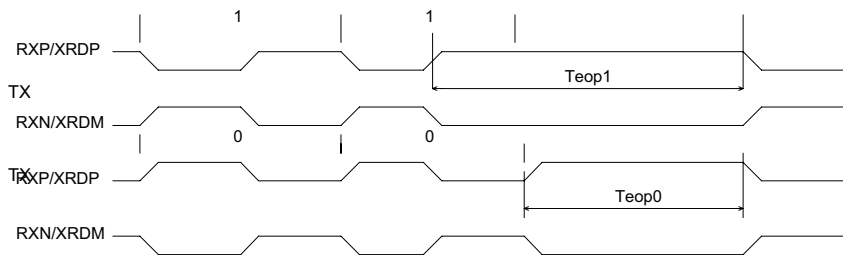

SYMBOL	DESCRIPTION	MIN.	MAX.	UNIT
Ttoh	Transmit Output High Before Idle	200		nS
Ttoi	Transmit Output Idle Time		8000	nS

AUI/UTP RECEIVE TIMING (END OF RECEIVE)

SYMBOL	DESCRIPTION	MIN.	MAX.	UNIT
T_{eop1}	End of Packet Received Hold Time after Logic "1" (Note 1)	200		nS
T_{eop0}	End of Packet Received Hold Time after Logic "0" (Note 1)	200		nS

Note 1: This parameter is specified by design and is not tested.



TPI TRANSMIT TIMING (END OF TRANSMIT)

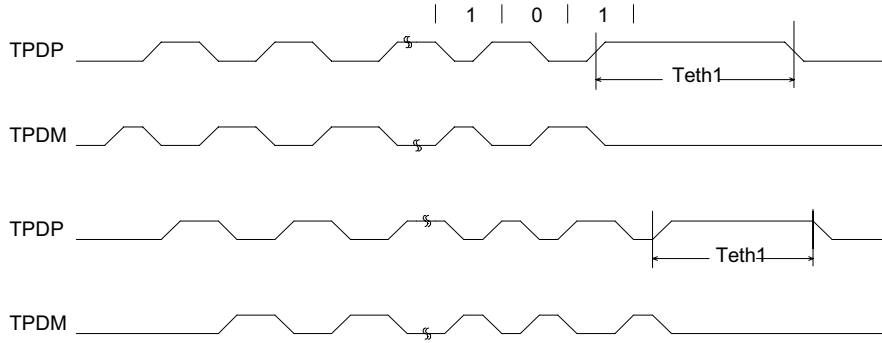

SYMBOL	DESCRIPTION	MIN.	MAX.	UNIT
T_{eth1}	End of Packet Transmitted Hold Time 1 (TPDP/M) (Note 1)	250		nS

Link Pulse Timing

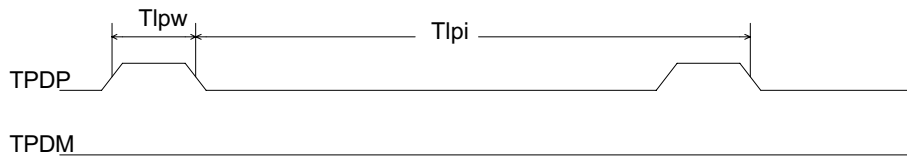

SYMBOL	DESCRIPTION	MIN.	MAX.	UNIT
T_{lpi}	Link Output Pulse Interval	8	24	mS
T_{lpw}	Link Output Pulse Width	80	120	nS



Serial EEPROM Timing

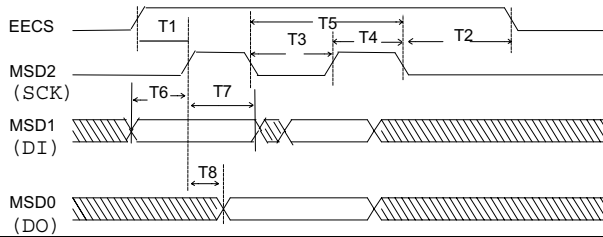

SYMBOL	DESCRIPTION	MIN.	MAX.	UNIT
T1	EECS asserted to SK	500		nS
T2	EECS hold from SK	0	500	nS
T3	MSD2 OFF time	500	600	nS
T4	MSD2 ON time	500	600	nS
T5	MSD2 clock period	1	1.2	μS
T6	MSD1 set up time to MSD2 high	500	600	nS
T7	MSD1 hold time from MSD2 high	500	600	nS
T8	MSD0 valid from MSD2 high		300	nS



AC TIMING CONDITIONS

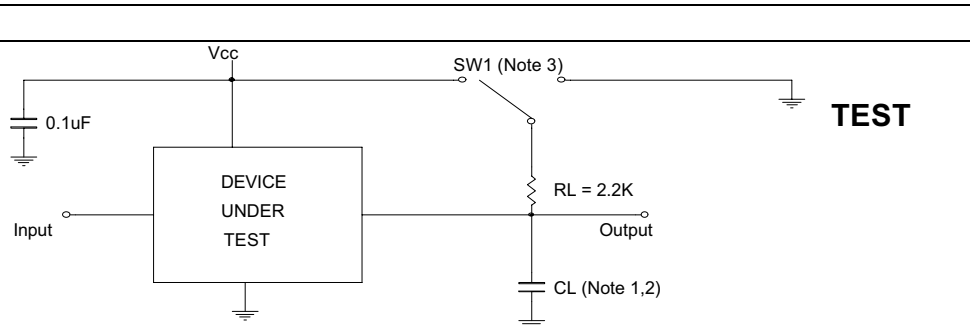

PARAMETER	TEST CONDITION
Supply voltage (V_{DD}/V_{SS})	5V±5%
Temperature	25°C/70°C
Input Test Pattern Levels (TTL/CMOS)	GND to 4.0V
Input Rise and Fall Times (TTL/CMOS)	5nS
Input and Output Pattern Reference Level (TTL/CMOS)	1.5V
Input Waveform Level (Diff)	-350 to -1315 mV
Input and Output Waveform Reference Levels	50% Point of the Differential
Tristate Reference Levels	Float (V) + 0.5V

Note 1: These parameters are specified by design and are not tested.

OUTPUT LOAD

The above specifications are valid only if the mandatory isolations are correctly employed and all differential signals are taken to the AUI of the pulse transformer.

Note 1: Load capacitance employed depends on output type.

For 3SL, MOS, TPI, AUI: CL=50 pF.

For 3SH, OCH: CL=240 pF.

Note 2: Specifications which measure delays from an active state to a High-Z state are not guaranteed by production test, but are characterized using 240 pF and are correlated to determine true driver turn-off time by eliminating inherent R-C delay times in measurements.

Note 3: SW1=Open for push pull outputs during timing test.

SW1=VCC for VOL test.

SW1=GND for VOH test.

SW1=VCC for High-Z to active low and active low to High-Z measurements.

SW1=GND for High-Z to active high and active high to High-Z measurements.

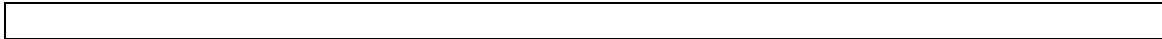

Pin Capacitance

TA = 25°C f = 1 MHz

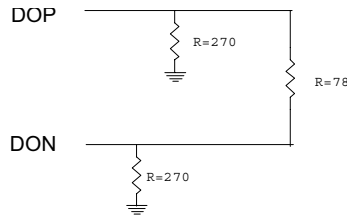

SYMBOL	PARAMETER	TYP	UNIT
C _{IN}	Input Capacitance	7	pF
C _{OUT}	Output Capacitance	10	p

DERATING FACTOR

Output timing is measured with a purely capacitive load of 50pF or 240pF.

The following correction factor can be used for other loads (this factor is preliminary only):

Derating for 3SL, MOS = -0.05 nS/pF.

Derating for 3SH, OCL, TPI = -0.03 nS/pF.

AUI TRANSMIT TEST LOAD

Note: In the above diagram, the TX+ and TX- signals are taken from the AUI side of the pulse transformer.

The pulse transformer used for all testing is a 100μH +/-0.1% Pulse Engineering PE64103.

PACKAGE DIMENSIONS

100 PINS PQFP

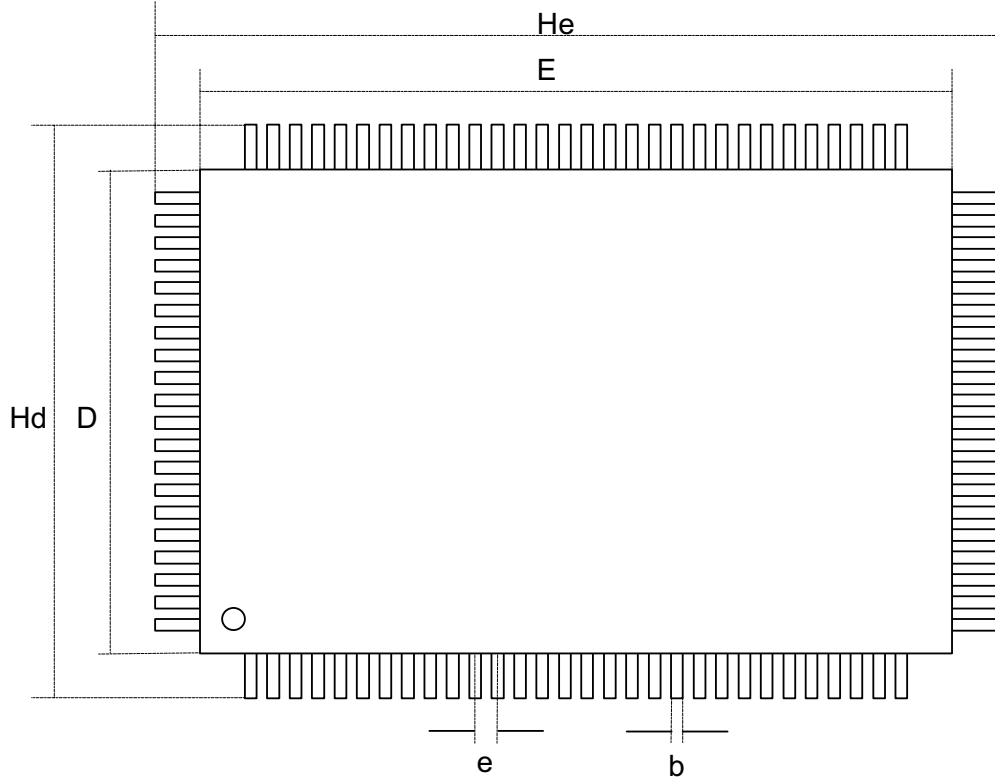

Symbol	Dimension in inch	Dimension in mm
A1	0.004 min	0.102 min
A2	0.112± 0.005	2.845± 0.127
b	0.012+ 0.004 - 0.002	0.350+ 0.102 - 0.051
C	0.006+ 0.004 - 0.002	0.152+ 0.102 - 0.051
D	0.551± 0.005	14.000 ± 0.127
E	0.787± 0.005	20.000 ± 0.127
e	0.026± 0.006	0.650± 0.152
Hd	0.740± 0.012	18.796 ± 0.305
He	0.976± 0.012	24.790 ± 0.305
L	0.047± 0.008	1.194± 0.203
L1	0.095± 0.008	2.413± 0.203
Y	0.004 MAX	0.102 MAX
@	0 ----- 12	0 ----- 12

