



W90210F

PA-RISC Embedded Controller

Table of Contents

TABLE OF CONTENTS	2
1. GENERAL DESCRIPTION	5
2. FEATURES	6
3. W90210F 208-PIN PQFP PIN CONFIGURATION	7
4. W90210F PIN DESCRIPTION	8
5. W90210F CPU CORE	12
5.1 Architecture	12
5.1.1 PA-RISC Rev. 1.1 third edition	12
5.1.2 Level 0 implementation	12
5.1.3 Multimedia Extension Instruction Set	12
5.2 CPU resources	12
5.2.1 General registers	12
5.2.2 Shadow registers	13
5.2.3 Processor Status Word (PSW)	13
5.2.4 Control registers	14
5.2.5 W90210F External Interrupt Request register (EIRR; CR23)	15
5.2.6 AIRs (Architecture Invisible Registers)	15
5.3 Implementation of the PA-RISC instructions	15
5.3.1 Implementation of Level 0 instructions	16
5.3.2 Implementation of cache-related instructions	16
5.3.3 PA-RISC multimedia extension instruction set	17
5.3.4 DIAG instruction	17
5.4. Debug Special Function Unit	19
5.5 Addressing and access control	20
5.5.1 Memory and I/O space	20
5.5.2 RESET addresses	20
5.5.3 Access control	20
5.6 Interruptions	21
6. PIPELINE ARCHITECTURE	22

6.1 Branch prediction	22
6.2 Load use interlock	23
7. ON-CHIP CACHE MEMORIES	24
7.1 Instruction cache	24
7.2 Data cache	24
7.2.1 Write-through Cache Support	25
7.3 Non-cacheable address space	25
8. MEGACELLS DESCRIPTION	26
8.1 DRAM Controller & ROM Controller	26
8.1.1 DRAM controller	26
8.1.2 ROM controller	27
8.1.3 Memory controller registers	27
8.2 DMA Controller (DMAC)	30
8.2.1 Register Description:	30
8.3 Timer / Counter	32
8.4 Serial I/O	33
8.4.1 UART Register Definition	33
8.5 Parallel Port	36
8.5.1 ECP Register Description	36
9. TIMING DIAGRAM	39
9.1 Memory controller	39
9.1.1 DRAM AC Timing	39
9.1.2 ROM AC Timing	39
9.2 DMA Controller	41
9.2.1 DMA device register read timing	41
9.2.2 DMA device register write timing	42
9.2.3 DMA demand mode data read cycles	43
9.2.4 DMA demand mode data write cycles	44
9.2.5 DMA block mode data read cycles	45
9.2.6 DMA block mode data write cycles	46
APPENDIX A. PA-RISC MULTIMEDIA INSTRUCTION SET	48
APPENDIX B. DIAGNOSTIC INSTRUCTIONS	53

1. General Description

The W90210F Embedded Controller is part of Winbond's W90K Embedded processor family. The processor is a high-performance, highly integrated 32-bit processor intended for a wide range of embedded applications, such as set-top box, web browser, X-terminal, and visual/data communication devices..

The W90210F CPU core is based on the HP PA-RISC architecture and is upward code compatible with the W90K. The PA-RISC architecture incorporates traditional RISC elements, such as instruction pipelining, a register-to-register instruction set and a large, general-purpose register file. Separate on-chip instruction and data caches allow the W90210F to fetch an instruction and access data in a single processor cycle.

The W90210F includes several features that greatly increase performance, reduce system component count and ease the overall system design task. In addition to its cache memories, the W90210F's on-chip support features include a DRAM controller, ROM/FLASH ROM interface, PCI bridge, DMA controller, two serial ports with FIFO, IEEE 1284 parallel port, timer/counters, and enhanced debug support- all features that are commonly required in embedded applications.

Figure 1.1 shows the system diagram of W90210F.

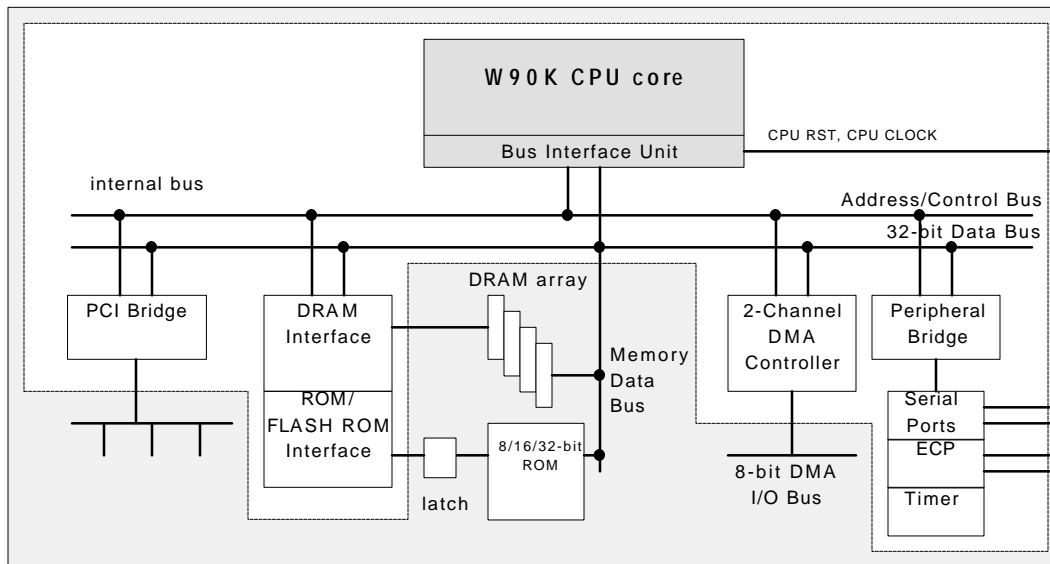

Figure 1.1 W90210F System Diagram

2. Features

Main features of the W90210F

- PA-RISC architecture
 - PA-RISC 1.1 third edition instruction set
 - PA-RISC level zero implementation
 - Support PA-RISC Multimedia Extension 1.0 instruction set
 - W90K binary compatible for user software
- High-performance implementation
 - Five-stage pipeline
 - Precise, efficient handling of pipeline stalls and exceptions
 - Delayed branch with static branch prediction
 - Forward: not taken
 - Backward: taken
 - One-cycle stall when prediction is wrong
 - HIT under miss
 - Both load and store can be queued when miss
 - Load/store single cycle execution after previous miss
- On-chip cache memory
 - Internal I-cache: Direct mapped, 4 KB cache (256 entries, four words/entry)
 - Wrap around fetching when cache miss
 - Cache freeze capability
 - Internal D-cache: 2-way set associative, 2 KB cache (64 entries, four words/entry)
 - Write-back cache with write buffer
 - Write-through option
 - New line send to CPU before dirty line write back
- Enhanced debug capability
 - Debug SFU supports both instruction breakpoints and data breakpoints
- High on-chip integration and simple I/O interface
 - 486-like bus interface for CPU core
 - Memory controller to support four banks of DRAM and ROM/FLASH ROM
 - 2-channel 8-bit DMA controller
 - PCI bridge
 - Two Serial ports with FIFO
 - Extended Capabilities Port (ECP)
 - Two 24-bit timer/counters
- Power Down mode
 - Provide power down mode for power saving operation

3. W90210F 208-Pin PQFP Pin Configuration

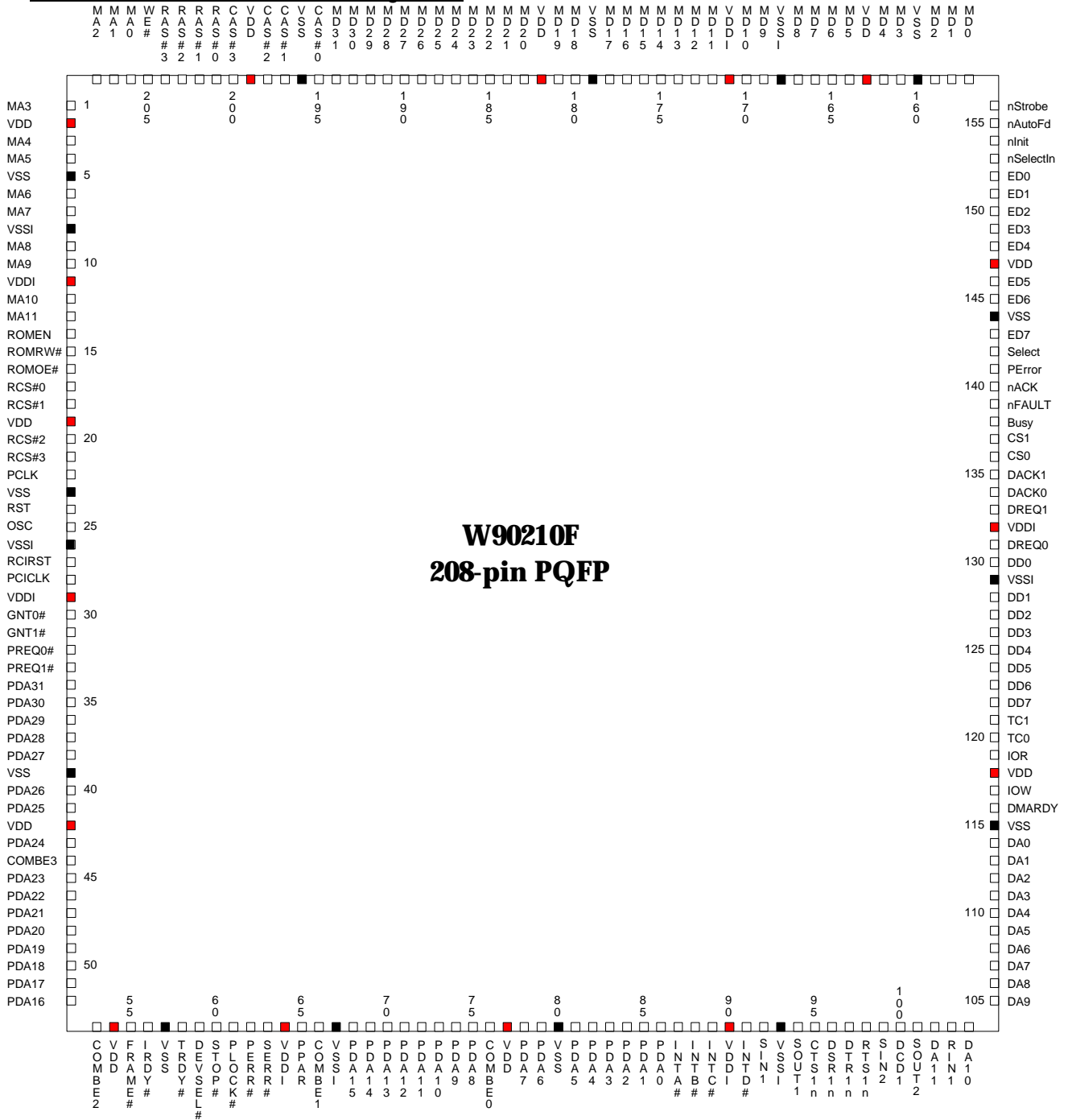

4. W90210F Pin Description

PIN Name	DIR	PIN #	DESCRIPTION
CPU Signal			
RST	I	24	CPU RESET input, high active
PCLK	I	22	CPU CLOCK input
OSC	I	25	14.318Mhz Oscillator input for Timer, UART
PCI LOCAL BUS			
			for more detail description of the PCI signals please refer to the PCI LOCAL BUS SPECIFICATION
INTA#	I	87	PCI Interrupt input, level sensitive, low active signal. Once the INTx# signal is asserted, it remains asserted until the device driver clears the pending request. When the request is cleared, the device deasserts its INTx# signal.
INTB#		88	
INTC#		89	
INTD#		91	
PREQ0#	I	32	PCI Request input, indicates to the PCI arbiter that this agent desires use of the bus.
PREQ1#		33	
GNT0#	O	30	PCI Grant output, indicates to the agent that access to the bus has been granted.
GNT1#		31	
PLOCK#	I	61	PCI Lock signal, indicates an atomic operation that may require multiple transactions to complete. When PLOCK# is asserted, non-exclusive transactions may proceed to an address that is not currently locked.
PCIRST#	O	27	PCI Reset output, is used to bring PCI-specific registers, sequencers, and signals to a consistent state. Low active.
PCICLK	O	28	PCI Clock output, provides timing for all transactions on PCI and an input to every PCI device.
SERR#	I	63	PCI System Error is for reporting address parity errors, data parity errors on the Special Cycle command, or any other system error where the result will be catastrophic. The assertion of SERR# is synchronous to the clock and meets the setup and hold times of all bused signals.
PERR#	I/O	62	PCI Parity Error is only for the reporting of data parity errors during all PCI transactions except a Special Cycle. The PERR# pin is sustained tri-state and must be driven active by the agent receiving data two clocks following the data when a data parity error is detected. The minimum duration of PERR# is one clock for each data phase that a data parity error is detected. An agent cannot report a PERR# until it has claimed the access by asserting DEVSEL# (for a target) and completed a data phase or is the master of the current transaction.

PDA[31:0]	tri-state I/O	34-38, 40-41, 43, 45-52, 68-75, 78- 79, 81-86	PCI tri-state Address/Data bus, Address and Data are multiplexed on the same PCI pins. A bus transaction consists of an address phase followed by one or more data phases. PCI supports both read and write bursts. The address phase is the clock cycle in which FRAME# is asserted. During the address phase PDA[31:0] contain a physical address. During data phases PDA[7:0] contain the least significant byte (lsb) and PDA[31:24] contain the most significant byte (msb). Write data is stable and valid when IRDY# is asserted and read data is stable and valid when TRDY# is asserted. Data is transferred during those clocks where both IRDY# and TRDY# are asserted.
STOP#	I/O	60	PCI Stop indicates the current target is requesting the master to stop the current transaction.
TRDY#	I/O	58	PCI Target Ready indicates the selected device's ability to complete the current data phase of the transaction. A data phase is completed on any clock both TRDY# and IRDY# are sampled asserted. During a read, TRDY# indicates that valid data is present on PDA[31:0]. During a write, it indicates the target is prepared to accept data. Wait cycles are inserted until both IRDY# and TRDY# are asserted together.
DEVSEL#	I/O	59	PCI Device Select, when actively driven, indicates the driving device has decoded its address as the target of the current access. As an input, DEVSEL# indicates whether any device on the bus has been selected.
C/BE[3:0]#	I/O	44,53,66,76	PCI Bus Command and Byte Enables are multiplexed on the same PCI pins. During the address phase of a transaction, C/BE[3:0]# define the bus command. During the data phase C/BE[3:0]# are used as Byte Enables. The Byte Enables are valid for the entire data phase and determine which byte lanes carry meaningful data. C/BE[0]# applies to byte 0 (lsb) and C/BE[3]# applies to byte 3 (msb).
FRAME#	I/O	55	PCI Cycle Frame is driven by the current master to indicate the beginning and duration of an access. FRAME# is asserted to indicate a bus transaction is beginning. While FRAME# is asserted, data transfers continue. When FRAME# is deasserted, the transaction is in the final data phase or has completed.
IRDY#	I/O	56	PCI Initiator Ready indicates the bus master's ability to complete the current data phase of the transaction. A data phase is completed on any clock both IRDY# and TRDY# are sampled asserted. During a write, IRDY# indicates that valid data is present on PDA[31:0]. During a read, it indicates the master is prepared to accept data. Wait cycles are inserted until both IRDY# and TRDY# are asserted together.
PPAR	I/O	65	PCI Parity is even parity across PDA[31:0] and C/BE[3:0]#. PPAR is stable and valid one clock after the address phase. For data phases, PPAR is stable and valid one clock after either IRDY# is asserted on a write transaction or TRDY# is asserted on a read transaction. (PPAR has the same timing as PDA[31:0], but it is delayed by one clock.) The master drives PPAR for address and write data phases; the target drives PPAR for read data phase.
DMA Interface			

DREQ0 DREQ1	I	131 133	DMA Request signals request an external transfer on DMA channel 0 (DREQ0) or DMA channel 1 (DREQ1).
DACK0 DACK1	O	134 135	DMA Acknowledge signals acknowledge an external transfer on DMA channel 0 (DREQ0) or DMA channel 1 (DREQ1).
DMARDY	I	116	DMA Device Ready signal is used to extend the length of DMA bus cycles. If a device wants to extend the DMA bus cycles, it will force the DMARDY signal low when it decodes its address and receives a IOR or IOW command.
CS0 CS1	O	136 137	DMA Chip Select signals select the corresponding I/O devices for programming or DMA transfers.
DA[0:11]	O	114-104,102	12-bit DMA I/O Address Bus, bit 0 is the most significant bit.
IOR	O	119	DMA I/O read signal is used to indicate to the I/O device that the present bus cycle is an I/O read cycle.
IOW	O	117	DMA I/O write signal is used to indicate to the I/O device that the present bus cycle is an I/O write cycle.
TC0 TC1	O	120 121	Terminal count for DMA channels, the pin is driven active for one clock when byte count reaches zero and after the last transfer for a DAM has completed.
DD[0:7]	I/O	130,128-122	8-bit DMA I/O Data bus, bit 0 is the most significant bit.
ECP Interface			For more detail description of the ECP interface signals, please refer to the IEEE P1284 Standard
Busy	I	138	ECP busy input signal
nFault	I	139	ECP fault input
nAck	I	140	ECP acknowledge input
PError	I	141	ECP parity error
Select	I	142	ECP Select
nSelectIn	O	153	ECP select output
nInit	O	154	ECP initialization
nAutoFd	O	155	ECP Autofeed
nStrobe	O	156	ECP Strobe
ED[0:7]	I/O	152-148,146-145,143	Bi-directional ECP Data bus, ED[0] is the most significant bit (msb).
Memory Controller Interface			
RAS#[0:3]	O	201-204	DRAM Row Address Strobe, Banks 0-3. These signals are used to select the DRAM row address. A High-to-Low transition on one of these signals causes a DRAM in the corresponding bank to latch the row address and begin an access.
CAS#[0:3]	O	195,197-198,200	DRAM Column Address Strobes, Byte 0-3. These signals are used to select the DRAM column address. A High-to-Low transition on these signals causes the DRAM selected by RAS#[0:3] to latch the column address and complete the access.
WE#	O	205	DRAM Write Enable signal is used to write the selected DRAM bank.
RCS#[0:3]	O	17-18,20-21	ROM Chip Selects, Banks 0-3. A low level on one of these signals selects the memory devices in the corresponding ROM bank.
ROMEN	O	14	ROM Address Latch, ROM address are divided into two portions, higher address bits and lower address bits, the address will be put out on the MA bus in two consecutive cycles. The ROMEN signal is used to latch the higher address bits in the first ROM address cycle.

ROMRW#	O	15	FLASH ROM write enable. This signal is used to write data into the mrmory in a ROM bank (such as Flash ROM).
ROMOE#	O	16	ROM output enable. This signal enables the selected ROM Bank to drive the MD bus.
MA[0:11]	O	206-208,1,3-4,6-7,9-10,12-13	Memory controller Memory Address bus. For DRAM access, MA[0:11] is the DRAM row address and the DRAM column address. For ROM/FLASH ROM access, MA[0:11] is the higher portion ROM space address bits in the first ROM address cycle, and the lower portion ROM space address bits after the first ROM address cycle. MA[0] is the most significant bit (msb).
MD[0:31]	I/O	157-159,161-162,164-167,169-170,172-178,180-181,183-194	Memory controller Data bus for both DRAM data and ROM space data. Bit 0 is the most significant bit (msb).
COM1 Serial Port Signal			
SIN1	I	92	COM1 serial data input from the communication link (modem or peripheral device).
SOUT1	O	94	COM1 serial data output to the communication link (modem or peripheral device).
CTS1n	I	95	COM1 clear to send signal
DSR1n	O	96	COM1 data set ready
DTR1n	I	97	COM1 data terminal ready
RTS1n	O	98	COM1 request to send
DCD1n	I	100	COM1 data carrier detect
RIN1n	O	103	COM1 ring indicator
COM2 Serial Port Signal			
SIN2	I	99	COM2 serial data input from the communication link (modem or peripheral device).
SOUT2	O	101	COM2 serial data output to the communication link (modem or peripheral device).

5. W90210F CPU Core

The key characteristics of the W90210F CPU core have been designed specifically to meet the requirements of embedded control applications. The following subsections describe the essential features of the W90210F CPU core, including its architecture, implementations, and registers.

5.1 Architecture

The W90210F CPU core is designed based on the powerful PA-RISC architecture. Since our target is high-end embedded applications, a great deal of design effort has been devoted to taking full advantage of this powerful architecture.

5.1.1 PA-RISC Rev. 1.1 third edition

The core of the W90210F is a processor unit that complies with PA-RISC architecture Rev. 1.1 third edition specifications. There are three kinds of operations to be executed by the processor; *branch*, *load/store*, and *data transform*. Most RISC architecture chooses to execute one of the three operations in an instruction. On the contrary, most PA-RISC instructions perform two operations listed above. For example, "ADD and BRANCH on the result of the ADD" can be done with one PA-RISC instruction. W90210F CPU core implements these powerful instructions and executes them in a single cycle. With such a powerful combined operation instruction set, the code size of W90210F can be much smaller than other RISC system. With the single cycle execution capability of these instructions, W90210F deliver very high throughput.

5.1.2 Level 0 implementation

In the PA-RISC architecture, a processor without an MMU is defined as the Level 0 implementation. All memory and I/O accesses in a level 0 PA-RISC processor are in real mode. W90210F is a level 0 implementation of PA-RISC architecture.

5.1.3 Multimedia Extension Instruction Set

The PA-RISC Multimedia extensions consists of a set of instructions which speed up the execution of common operations found in multimedia applications. In a 32-bit integer datapath, each multimedia instruction allows generic arithmetic operations to be executed in parallel on two pairs of 16-bit data. The PA-RISC multimedia extensions 1.0 instruction set is implemented by the W90210F CPU core.

5.2 CPU resources

The W90210F CPU core implements all the registers needed for a Level 0 processor as defined in the PA-RISC specifications. Some registers or register bits are not needed in a Level 0 processor and are defined as nonexistent registers or register bits. The W90210F CPU implements three AIRs (Architecture Invisible Registers) that can be accessed by executing DIAG instructions.

5.2.1 General registers

Thirty-two 32-bit general registers provide the central resource for all computation. They are numbered GR 0 through GR 31, and are available to all program at all privilege levels. GR 0, when referenced as source operand, delivers zeros. When GR 0 is used as destination, the result is discarded. GR 1 is the target of the ADD IMMEDIATE LEFT instruction. GR 31 is the instruction address offset link register for the base relative interspace procedure call instruction. GR 1 and GR 31 can also be used as general register.

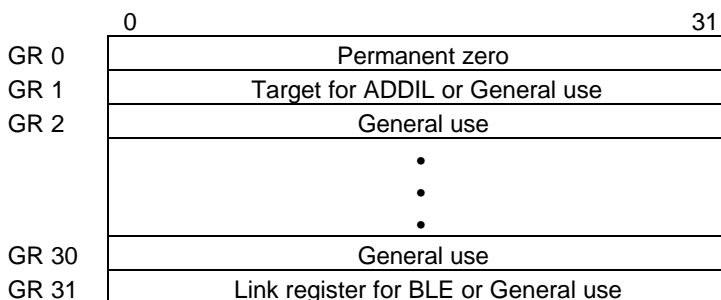
Figure 5.1 General Registers
5.2.2 Shadow registers

W90210F CPU core provides seven registers called shadow registers as defined in the PA-RISC architecture. The contents of GR1,8,9,16,17,24 and 25 are copied upon interruptions. Shadow registers reduce the state save and restore time by eliminating the need for general register saves and restores in interruption handlers. The behavior of the shadow registers is described below.

Before entering interrupt routine: Contents of seven general registers are copied into shadow registers in one cycle.

When executing RFIR: Contents of shadow registers are copied into general registers automatically in one cycle.

5.2.3 Processor Status Word (PSW)

The processor state of W90K is encoded in a 32-bit register called the Processor Status Word (PSW). The format of PSW is shown in figure 5.2. The old value of the PSW is saved in the Interrupt Processor Status Word (IPSW) when interruption occurs. The PSW is set to the contents of the IPSW by the RFIR (RETURN FROM INTERRUPTION and RESTORE) instruction.

			1	1	1	1	1	1	1										2	2	2	2	2	2	3	3		
0	1	2... 4	5	6	7	8	9	0	1	2	3	4	5	6	...	3	4	5	6	7	8	9	0	1				
Y	Z	rv	E	S	T	H	L	N	X	B	C	V	M	C/B		rv	G	F	R	Q	P	D	I					
Field	Description																											
rv	Reserved bits.																											
Y	Data debug trap disable.																											
Z	Instruction debug trap disable.																											
E	Little endian mode enable. When 1, all instruction fetches and loads/stores are little endian. The E bit after RESET is set according to the state of ENDIAN pin.																											
S	Secure Interval Timer. When 1, the Interval Timer is readable only by code executing at the most privileged level. When 0, the Interval Timer is readable by code executing at any privilege level.																											
T	Taken branch enable. When 1, any taken branch is terminated with a taken branch trap.																											
H	Higher-privilege transfer trap enable.																											
L	Lower-privilege transfer trap enable.																											
N	Nullify. The current instruction is nullified when this bit is 1.																											
X	Non-existent register bit.																											
B	Taken branch. The B-bit is set to 1 by any taken branch instruction and set to 0 otherwise.																											
C	Non-existent register bit.																											
V	Divide step correction. The integer primitive instruction records intermediate status in this bit to provide a non-restoring divide primitive.																											
M	High-priority machine check mask. When 1, High Priority Machine Checks (HPMCs) are masked. Normally 0, this bit is set to 1 after HPMC and set to 0 after all other interruptions.																											
C/B	Carry/borrow bits. These bits are updated by some instructions from the corresponding carry/borrow outputs of the 4-bit digit of the ALU.																											
G	Debug trap enable.																											
F	Non-existent register bit.																											

R	Recovery counter enable. When 1, recovery counter traps occur if bit 0 of the recovery counter is a 1. This bit also enables decrementing of the recovery counter.
Q	Interrupt state collection enable. When 1, interruption state is collected.
P	Non-existent register bit.
D	Non-existent register bit.
I	External interruption, power failure interrupt, and low-priority machine check interruption unmask. When 1, these interruptions are unmasked and can cause an interruption.

Figure 5.2 Processor Status Word

5.2.4 Control registers

There are twenty-five control registers in W90210F, numbered CR0, and CR8 through CR31, which contain system state information. Figure 5.3 shows the control registers. The access of CR 11, 16, 26, and 27 are described in the following table (table 5.4). Those control registers not listed in table 5.4 are only accessible by code executing at the most privileged level. Control registers 1 through 7 are reserved registers. The unused bits of the Coprocessor Configuration Register are reserved bits. The unused bits of the Shift Amount Register are nonexistent bits. In Level systems, CRs 8, 9, 12, 13, 17, and 20 are nonexistent registers.

	0	31
CR 0	Recovery Counter	
CR 1	reserved	
	•	
	•	
	•	
CR 7	reserved	
CR 8	Nonexistent registers	
CR 9	Nonexistent registers	
CR 10	reserved	SCR (8 bits) CCR (8 bits)
CR 11	nonexistent	SAR (5)
CR 12	Nonexistent registers	
CR 13	Nonexistent registers	
CR 14	Interruption Vector Address	reserved
CR 15	External Interrupt Enable Masks	
CR 16	Interval Timer	
CR 17	Nonexistent registers	
CR 18	Interruption Instruction Address Offset Queue	
CR 19	Interruption Instruction Register	
CR 20	Nonexistent registers	
CR 21	Interruption Offset Register	
CR 22	Interruption Processor Status Word	
CR 23	External Interrupt Request Register	
CR 24	Temporary Registers	
	•	
	•	
	•	
CR 31	Temporary Registers	

Figure 5.3 Control registers

	Privilege level for the access
--	--------------------------------

CR 11	read/write at any privilege level
CR 16	PSW 'S'=0: read/write by any privilege level PSW 'S'=1: read/write by privileged software
CR 26, 27	readable at any privilege level writable at the most privileged level
Others	Accessible only at most privileged level

Table 5.4 Access of control registers

5.2.5 W90210F External Interrupt Request register (EIRR; CR23)

Bit Number	EI[0:4]	External Interrupt	Description
0	00000	Timer_Int	Interval Timer (CR16) interrupt request
1	10000	-	
2	01000	-	
3	11000	Serial	Serial port interrupt request from COM2
4	00100	INTA	PCI bus INTA# interrupt request
5	10100	INTB	PCI bus INTB# interrupt request
6	01100	INTC	PCI bus INTC# interrupt request
7	11100	INTD	PCI bus INTD# interrupt request
8	00010	Parallel_Int	Parallel port interrupt request
9	10010	Serial_Int	Serial port interrupt request from COM1
10	01010	DMA_Int	DMA interrupt request
11	11010	TC_Int	Timer/Counter interrupt request
12 - 31	-	-	Reserved

Table 5.5 External Interrupt Request Register

5.2.6 AIRs (Architecture Invisible Registers)

There are eight AIRs in the W90210F. AIR[0] controls the internal cache configuration, burst mode, and default endian. AIR[0] is documented in this data sheet. AIR[1] and AIR[2] are reserved for chip testing by Winbond, and their functions will not be disclosed to users. Attempting to access these two registers may cause programs to be executed with unpredictable results. Memory configuration registers are used for programming the configuration of W90210F memory space. AIR[7] is the PCO register, this AIR can only be accessed through the JTAG ICE interface.

AIR[0]	Internal configuration register
AIR[1]	PSW register
AIR[2]	TMR register
AIR[3]	Memory configuration register 1
AIR[4]	Memory configuration register 2
AIR[5]	Memory configuration register 3
AIR[6]	Memory configuration register 4
AIR[7]	PCO register (program counter)

Table 5.6 W90210F CPU core AIRs

Important: Enabling or disabling the internal I-cache with MTAIR[0] will invalidate all I-cache entries automatically. Enabling the internal D-cache with MTAIR[0] will invalidate all cache entries without dirty data entries being written back. Disabling the D-cache, however, will not invalidate cache entries.

Disabling the internal D-cache with MTAIR[0] will cause dirty data to be left in the D-Cache and not automatically written into memory. When a program references the dirty data location, stale data in memory will be returned. To prevent this, a cache invalidation routine should be performed before the internal D-cache is disabled. The invalidation routine must flush all cache entries one by one. This will invalidate the cache and also write back any dirty data.

AIR[1] and AIR[2] are reserved registers and should never be written to or read from them. Accessing these registers will cause unpredictable result.

5.3 Implementation of the PA-RISC instructions

The W90210F CPU core implements all the instructions specified in the PA-RISC Rev. 1.1 third edition. W90210F executes these instructions with results that comply to the PA-RISC architecture. MMU related instructions are executed by W90210F as defined in the PA-RISC architecture for a Level 0 processor. PA-RISC multimedia extension 1.0 instruction set is also supported by W90210F. To speed up multimedia operations in some applications, three additional instructions are defined through the diagnostic instructions. In addition to that, debug SFU is provided to enhance the debug capability. The chip also implements DIAG instructions defined by Winbond for chip testing, diagnostics, and programming the internal AIR (architecture invisible register). These DIAG instructions comply with the PA-RISC DIAG instructions.

5.3.1 Implementation of Level 0 instructions

In the Level 0 processor implementation, the S-fields of all instructions are ignored and have no effect on the device functions. The following instructions for TLB handling are executed as null instructions, as specified in the architecture reference manual:

Instruction	Function
PDTLB	Purge data TLB
PITLB	Purge instruction TLB
PDTLBE	Purge data TLB entry
PITLBE	Purge instruction TLB entry
IDTLBA	Insert data TLB address
IITLBA	Insert instruction TLB address
IDTLBP	Insert data TLB protection
IITLBP	Insert instruction TLB protection

Table 5.7 Instructions executed as null instructions

Table 5.8 lists the differences in instruction execution results in a Level 0 processor.

Instruction	Description	Difference
LPA	Load physical address	Undefined instruction
LCI	Load coherence index	Undefined instruction
LDWAX	Load word absolute index	Same as LDWX if priv=0
LDWAS	Load word absolute short	Same as LDWS if priv=0
STWAS	Store word absolute short	Same as STWS if priv=0
GATE	Gateway	Always promote priv to 0
BV	Branch vectored	Demote priv to any non zero value
BE	Branch external	Demote priv to any non zero value, IASQ is nonexistent
BLE	Branch and link external	
RFI	Return from interrupt	IASQ is nonexistent
RFIR	Return from interrupt and restore	
LDSID	Load space identifier	0 is written into specified GR
MTSP	Move to space register	Executed as null instruction
MTCTL	Move to control register	Executed as null instruction if target is 8,9,12,13,17 or 20
MFSP	Move from space register	is written into specified GR
MFCTL	Move from control register	0 is written into specified GR if source is 8,9,12,13,17 or 20
PROBER	Probe read access	Always set target GR to 1
PROBERI	Probe read access immediate	Always set target GR to 1
PROBEW	Probe write access	Always set target GR to 1
PROBEWI	Probe write access immediate	Always set target GR to 1

Table 5.8 Summary of Level 0 instruction differences

5.3.2 Implementation of cache-related instructions

It is assumed that in the W90210F application system all DMA transfers will be completed in order. The instruction for DMA cache synchronization SYNCDMA will be executed as a null instruction. The W90210F CPU core does not snoop the external bus to check the coherence of the cache. To ensure that the contents of the memory remain consistent, devices outside the W90210F CPU can access only non-cacheable memory. FLUSH and purge cache instructions will flush the internal cache only. The W90210F will not broadcast a flush or purge operation to the secondary cache or other bus master (if any).

FICE and FDCE are implemented as described below.

- FICE will flush all instruction cache entries. All instruction entries become invalid after the execution of FICE.
- FDCE is used to flush an individual cache entry. This instruction causes dirty data to be written back to memory.

The data cache in the W90210F has 2 x 64 entries. To flush the entire data cache, a loop that execute a flush to a single entry can be used to flush the entire data cache.

Instruction	Execution result
SYNCDMA	Null
FDCE, FICE	See description above
FDC, FDCE, FIC, FICE, PDC	Affect internal cache only and are not broadcast to external bus.

Table 5.9 Cache-related instructions and execution results

5.3.3 PA-RISC multimedia extension instruction set

The PA-RISC Multimedia extensions consists of a set of instructions which speed up the execution of common operations found in multimedia applications. Multimedia instructions perform multiple parallel operations in a single cycle.

Instruction	Description
HADD	Halfword parallel add
HSUB	Halfword parallel subtract
HAVE	Halfword parallel average
HSHRADD	Parallel halfword shift right and add
HSHLADD	Parallel halfword shift left and add

Table 5.10 PA-RISC multimedia instructions

5.3.4 DIAG instruction

DIAG instructions are a special instruction format defined by PA-RISC; the functions of these instructions depend on the specific implementation. These instructions are used to program special control registers in the W90K that are not visible in the PA-RISC architecture.

The DIAG instruction syntax is not supported by the assembler. A special macro file provided by Winbond must be included in user programs. The macro converts DIAG assembly instructions into a format recognized by the assembler. With the help of this file, users can employ the DIAG syntax described below for programming.

Instruction	Description
HALT	Force W90210F CPU enter the HALT state
MTAIR	Copies value into a specified AIR from a general register
MFAIR	Copies value into a general register from AIR register
MTITAG	Copies value into a specified Instruction Tag from a general register
MFITAG	Copies value into a general register from a instruction tag
MTICAH	Copies value into a specified Instruction cache from a general register
MFICAH	Copies value into a general register from a instruction cache entry
MTDTAG	Copies value into a specified data Tag from a general register
MFDTAG	Copies value into a general register from a data tag
MTDCAH	Copies value into a specified data cache from a general register
MFDCAH	Copies value into a general register from a data cache entry
LDHU	Load halfword and unpack
HABSADD	Halfword absolute and add

Table 5.11 DIAG instructions

5.4. Debug Special Function Unit

The debug special function unit is an optional, architected SFU which provides hardware assistance for software debugging using breakpoints. The debug SFU is currently provided in the W90210F CPU core. The debug SFU supports two sets of registers for both data breakpoints and instruction breakpoints.

For the instruction debug trap, the trapping address is stored in the interruption instruction address offset queue (IIAOQ). For the data debug trap, the trapping address is stored in the interruption offset register (IOR).

The e bit in each IBAMR determines whether this instruction breakpoint is enabled. If the e bit is 1, any attempt to execute an instruction (including nullified instructions) at an address matching the corresponding IBAOR will cause an instruction debug trap. If the e bit is 0, that instruction breakpoint is disabled.

Instruction Breakpoint Address Offset Register (IBAOR0, IBAOR1):

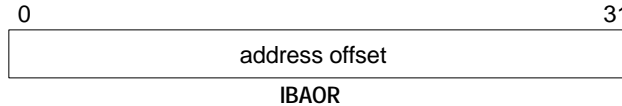

Instruction Breakpoint Address Mask Register (IBAMR0, IBAMR1):

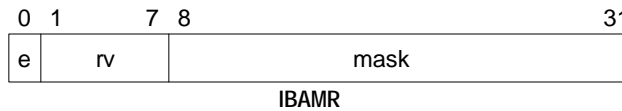

Data Breakpoint Address Offset Register (DBAOR0, DBAOR1):

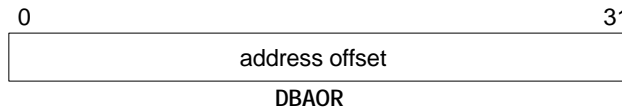

Data Breakpoint Address Mask Register (DBAMR0, DBAMR1):

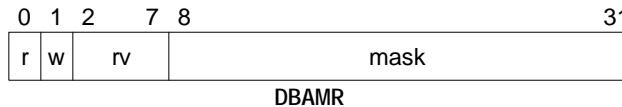

Figure 5.12 Debug SFU registers

The r and w bits in each DBAMR determine the type of access this data breakpoint is enabled for. If the r bit is 1, any non-nullified load or semaphore instruction to an address matching the corresponding DBAOR will cause a data debug trap. If the w bit is 1, any non-nullified store or semaphore instruction or cache purge operation to an address matching the corresponding DBAOR will cause a data debug trap. If the r and w bits are both 0, the data breakpoint is disabled.

For the control of the debug SFU, three bits are added to the PSW register.

Debug Trap Enable Bit (G): Bit 25 of the PSW is defined as the G-bit- the debug trap enable bit. When the G-bit is 1, the data debug trap and instruction debug trap are enabled; when 0, the traps are disabled. The G-bit is set to 0 on interruptions.

Data Debug Trap disable Bit (Y): Bit 0 of the PSW is defined as the Y-bit. The Y-bit is set to 0 after the execution of each instruction, except for RFI and RFIR instructions which may set it to 1. When 1, data debug traps are disabled.

Instruction Debug Trap disable Bit (Z): Bit 1 of the PSW is defined as the Z-bit. The Z-bit is set to 0 after the execution of each instruction, except for RFI and RFIR instructions which may set it to 1. When 1, instruction debug traps are disabled.

In addition, CCR bits 16- 23 are used as enable/disable bits for SFUs 0- 7. The debug SFU will use bit 17. When bit 17 is enabled, the SFU #1 instructions will operate normally, but when disabled, all SFU #1 instructions will take an assist emulation trap.

Two new exceptions are added to the architecture- one for instruction debugging and one for data debugging.

Instruction Debug Trap (30): Interruption #30 is now defined as the instruction debug trap. This trap belongs to group 3.

Data Debug Trap (31): Interruption #31 is defined as the data debug trap. This trap belongs to group3.

Following instructions are added for the debug SFU.

Mnemonic	Description	Operation
MTDBAO	Move to data breakpoint address offset register	DBAOR[t]←GR[r]
MFDBAO	Move from data breakpoint address offset register	GR[t]←DBAOR[r]
MTDBAM	Move to data breakpoint address mask register	DBAMR[t]←GR[r]
MFDBAM	Move from data breakpoint address mask register	GR[t]←DBAMR[r]
MTIBAO	Move to instruction breakpoint address offset register	IBAOR[t]←GR[r]
MFIBAO	Move from instruction breakpoint address offset register	GR[t]←IBAOR[r]
MTIBAM	Move to instruction breakpoint address mask register	IBAMR[t]←GR[r]
MFIBAM	Move from instruction breakpoint address mask register	GR[t]←IBAMR[r]
DEBUGID	Debug SFU identify	GR[t]←id number

Table 5.13 Debug SFU instructions

5.5 Addressing and access control

The W90210F implements real mode addressing. The total addressable space for the W90210F is 4 GB. Objects in the memory and I/O system are addressed using 32-bit absolute addresses. An absolute pointer is a 32-bit unsigned integer whose value is the address of the lowest addressed byte of the operand it designates. The address mapping is same as that specified by the PA-RISC architecture.

5.5.1 Memory and I/O space

X'00000000

X'FFFFFFF

X'F0000000

X'FFFFFFFF

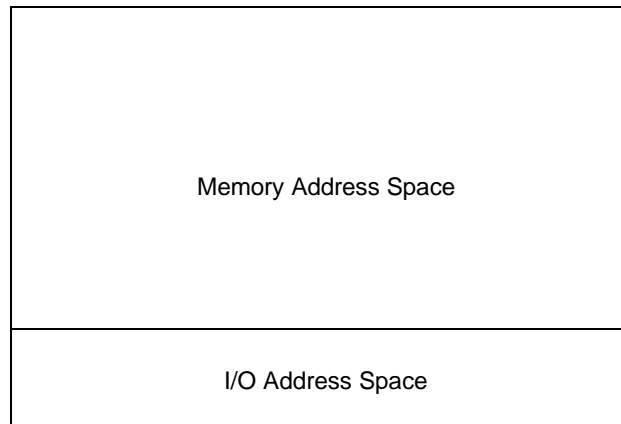

Figure 5.16 Memory and I/O addresses

Figure 5.16 shows the memory and I/O address space allocation.

Total memory address space available is (4 GB-256 MB). Total addressable I/O space is 256 MB.

Program address for I/O: Fxxxxxxx

W90210F CPU core output address: 0xxxxxxx

5.5.2 RESET addresses

The initial instruction address after a hardware reset is not defined in the PA-RISC architecture. Two reset addresses are provided for W90210F CPU core. W90210F CPU core will sample the input pin "PA/486#" at the trailing edge of RESET to determine the initial instruction address. When PA/486# pin is low, the initial address will be 000FFFF0; when PA/486# is high, it will be EFFFFFF0. This pointer ensures that the program starts execution from ROM space when used in an X86-compatible board. W90210F CPU core has an internal pull down resistor that will set W90210F CPU to generate X86-like initial address if the PA/486# is left unconnected.

For W90210F, the reset address is always EFFFFFF0.

5.5.3 Access control

Every instruction is fetched and executed at one of four privilege levels (numbered 0,1 2, 3) with 0 being the most privileged. The privilege level is kept in the bits 30 and 31 of the current instruction's address. Base relative branch instructions (BV, BE and BLE) will demote privilege level to any non zero value, if it changes it. GATEWAY instruction promotes the privilege level to 0. Other branch instructions have word offset only and will not change privilege level.

5.6 Interruptions

Interruptions are anomalies that occur during instruction processing causing the flow control to be passed to an interruption handling routine. The interruptions are categorized into four groups based on their priorities. Interruption numbers in table 5.17 are the individual vector numbers that determine which interruption handler is invoked for each interruption. The group numbers determine when the particular interruption will be processed during the course of instruction execution. The order the interruptions are listed within each group determines the priority of simultaneous interruptions (from highest to lowest).

Group	interruption number	Interruption
1	1	High-priority machine check
2	2	Power failure interrupt
	3	Recovery counter trap
	4	External interrupt
	5	Low-priority machine check
3	30	Instruction debug trap
	8	Illegal instruction trap
	9	BREAK instruction trap
	10	Privileged operation trap
	11	Privileged register trap
	12	Overflow trap
	13	Conditional trap
	31	Data debug trap
4	22	Assist emulation trap
	23	Higher-privilege transfer trap
	24	Lower-privilege transfer trap
	25	Taken branch trap

Table 5.17 Interruption number

Interruption handler routine begins execution at the address given by:

$$\text{Interruption Vector Address} + (32 * \text{interruption_number})$$

However, handler of HPMC will start at 'initial address + 4', where 'initial address' is the first instruction address issued by W90K after RESET. There are two initial address (determined by PA/486#), X'000FFFF0 or X'FFFFFFF0. HPMC handler will start from either X'000FFFF4 or X'FFFFFFF4. This arrangement is to ensure that HPMC handler will start first at a ROM address that is more reliable than DRAM.

6. Pipeline Architecture

The pipeline used in the W90210F CPU core is a typical five-stage pipeline. Most instructions are executed in one single cycle except long instructions. Long instructions are FDC, FDCE, FIC, FICE, PDC, RFIR, and RFI. For Branch instruction, one delay slot is needed.

The pipeline is shown below:

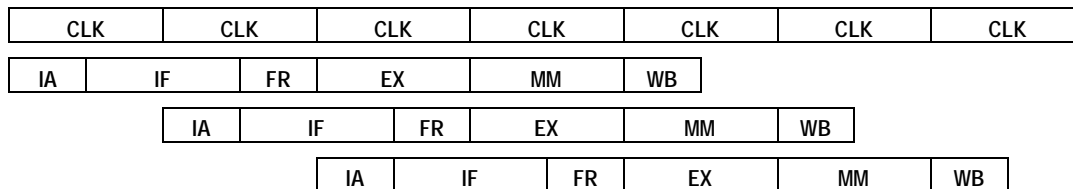

- IA: Instruction address calculation
- IF: Instruction fetch
- FR: Register fetch and decode
- EX: Execution and data address calculation
- MM: Memory reference for Load/Store instruction
- WB: Write back to register file

Figure 6.1 W90K pipeline architecture

IA: The instruction address for the cycle is generated. The sources of the instruction address are n+1, branch target, interrupt vector, IIAOQ, and reset pointer. The address is calculated and selected within half cycle.

IF: Instruction cache is fetched during this cycle. Instruction will be available before end of IF. IMISS (instruction cache miss) will be available at the second half of IF.

FR: The instruction from IF stage is used to access the register file and decoded for execution. The bypass control is also generated to select the correct bypass path. If the instruction is a cache miss, the pipeline will stall at this stage.

EX: The instruction is executed in this stage. For branch instructions, a dedicated adder is used to calculate the target address at the first half of EX (corresponding to the IA stage of the instruction after the delay slot). The condition check is also performed in this stage for conditional branch instruction. Data address for memory reference instruction is also calculated in this stage. For non-nullified MTCTL instruction, data will be written into CR at the end of the EX stage. External traps (EI, HPMC, LPMC and PFW) will be sampled at the EX stage and piped to the WB stage for trap handling.

MM: The data cache is referenced at this stage.

WB: The data from EX or MM stage will be written back to register file in the first half of the WB stage. The data can be read out by the FR stage in the same cycle; otherwise one extra bypass will be needed. If the MM stage of this instruction is a miss and a data dependence exists, the pipeline will stall at the WB stage; otherwise, the pipeline will continue.

6.1 Branch prediction

Static branch prediction is used for conditional branch instructions in W90210F CPU core.

Forward branch: predict not taken

Backward branch: predict taken

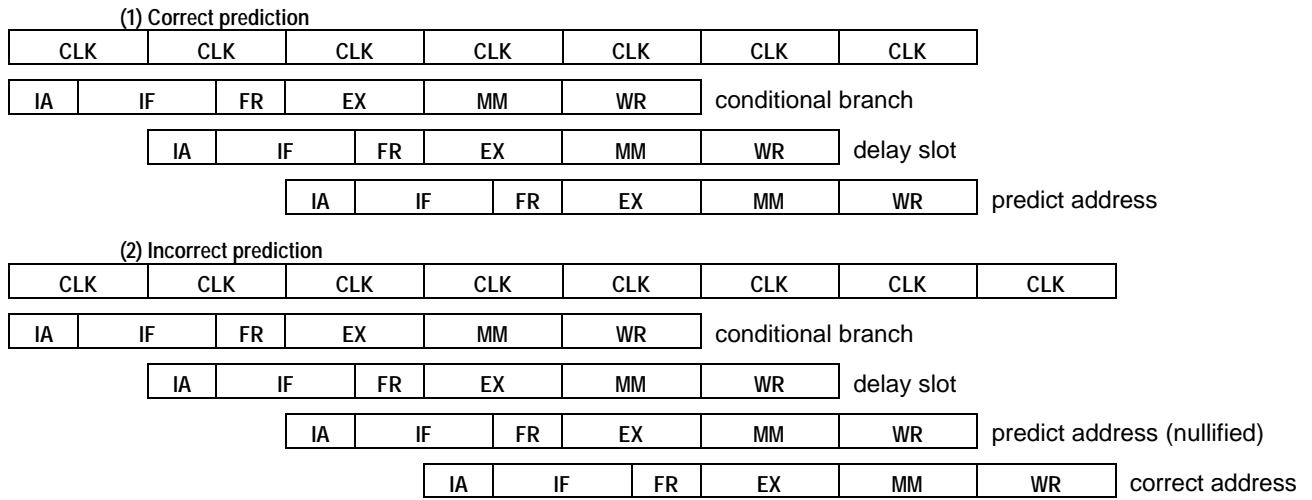

Figure 6.2 Pipeline operation for branch prediction.

6.2 Load use interlock

Load use interlock: A one-cycle interlock will be forced by hardware when load use dependence occurs.

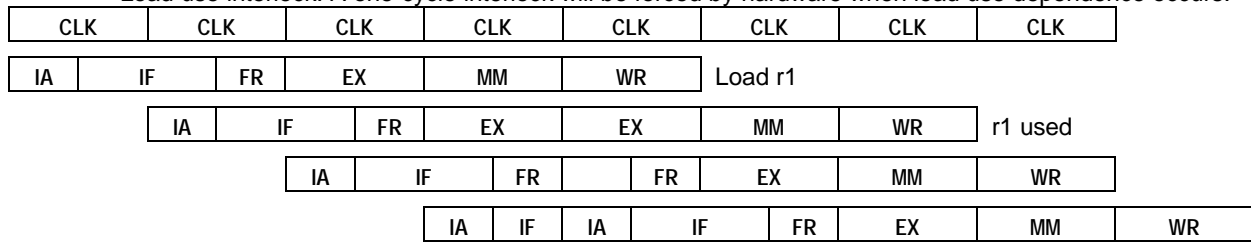

Figure 6.3 Load-use interlock pipeline operation

7. On-Chip Cache Memories

The W90210F contains a 4-Kbyte instruction cache and a 2-Kbyte data cache. Cache memories hold instructions and data that are repetitively accessed by the CPU and thus reduce the number of references that must be made to the slower main memory. The internal cache uses a Harvard architecture, so the bandwidth between the cache and processor is 2 words/cycle. Separate address and data bus are provided for I-cache and D-cache (Harvard architecture).

After reset, both internal caches are disabled and all memory accesses are forwarded to the external bus. AIR[0] is used to enable and disable the internal caches. A DIAG instruction (MTAIR) is the only instruction that can access AIR[0].

The instruction cache is a direct mapped cache and the data cache is a 2-way set associative cache. Common features for both caches are:

- 4 words per entry
- One valid bit per entry
- Wrap-around fill

The line size is four words with a single valid bit for all four words. The line size is the same as that of an i486 processor, since the W90210F CPU core is designed to use an 486-type bus. Four words per entry is an optimal value, considering the relatively small internal cache and the external bus bandwidth available.

The cache controller will request the BIU (Bus Interface Unit) for missed addresses. A whole line will be filled after a cache miss, since only one valid bit is available. The BIU will first return the word needed (not necessarily the first word in the entry) for program execution, and the processor will continue once the first word is returned. The remaining three words will be filled into the cache while the program is executed; this is the so-called wrap-around refill scheme.

Important: Attempting to enable an internal cache after it has been enabled and then disabled will lead to unpredictable results, because the internal cache may contain stale data. Hence a cache invalidation routine that flushes all cache entries one by one must be performed before an internal cache is disabled. This will invalidate the cache and cause any dirty data to be written back to memory.

7.1 Instruction cache

Instruction cache is a 4-Kbyte direct mapped cache. The instruction cache is divided into four 1-Kbyte caches, and each 1-Kbyte cache can be freed individually by setting the corresponding cache freeze bit in the AIR[0].

The cache freeze function must be implemented by the pre-load method. User must fill the instruction cache with the desired routines by MTITAG and MTICAH diagnostic instructions and then set the corresponding freeze bit to freeze the particular routine in the instruction cache.

7.2 Data cache

The integrated Data cache has several features that are not shared by the I-cache. The features listed below have been added to enhance the efficiency of the D-cache:

- Write-back cache with write-through option
- Hit under miss
- Separate byte write enable

The integrated D-cache is a write-back cache by default. This minimizes the number of bus cycles needed between the CPU and the slow main memory system. Data are written back to main memory only when an entry with dirty data is to be replaced by a new address.

The address range for write-through cache option is programmable. User can program the write-through base register and the write-through region size register (memory configuration registers) by MTAIR instruction.

The "hit under miss" scheme is used in the W90210F. A cache hit data reference is completed in one cycle. When data miss occurs the W90210F will continue execution as long as the data are not needed. The BIU will perform data access for the miss cycle in parallel with the program execution. While the BIU is accessing the missed data, the internal D-cache can still be accessed by following load/store instructions. The W90K will stall only when missed data are

needed for the program execution (i.e., a data dependency is encountered) or when a second miss cycle occurs before the first miss cycle is serviced. The "hit under miss" scheme helps to minimize the D-cache miss penalty.

Separate byte write enables are provided for store instructions. This feature enables the W90210F to execute store byte(s) instructions without read-modify-write operation.

7.2.1 Write-through Cache Support

Normally, the data cache is a write-back cache. Range for the write-through cache address space can be defined in the AIR.

Write-through base register[0:15]: This register defines the base address of the write-through address range.

Write-through region size register: This register defines the size of the write-through address range:

000:	disable	
001:	64K	
010:	128K	(base address must be multiple of 128K)
011:	256K	(base address must be multiple of 256K)
100:	512K	(base address must be multiple of 512K)
101:	1M	(base address must be multiple of 1M)
110:	2M	(base address must be multiple of 2M)
111:	4M	(base address must be multiple of 4M)

Important: User must flush the data cache before setting up these two registers.

7.3 Non-cacheable address space

User can define two non-cacheable regions with sizes ranging from 64K to 4M Byte. BIU can use these two ranges to decide whether current bus cycle is cacheable or not.

Non-cacheable base address register: This register defines the base address of the non-cacheable address range.

Non-cacheable region size register: This register defines the size of the non-cacheable address range:

000:	disable	
001:	64K	
010:	128K	(base address must be multiple of 128K)
011:	256K	(base address must be multiple of 256K)
100:	512K	(base address must be multiple of 512K)
101:	1M	(base address must be multiple of 1M)
110:	2M	(base address must be multiple of 2M)
111:	4M	(base address must be multiple of 4M)

The memory address space above 1MB, 2MB, 4MB, 8MB, 16MB, 64MB, 128MB or 256MB can also be turned into a third non-cacheable region. This is defined by the system non-cacheable region register: 0000: all cacheable

0001:	above 1MB
0010:	above 2MB
0011:	above 4MB
0100:	above 8MB
0101:	above 16MB
0110:	above 32MB
0111:	above 64MB
1000:	above 128MB
1001:	above 256MB

8. Megacells Description

8.1 DRAM Controller & ROM Controller

8.1.1 DRAM controller

The DRAM controller supports four separate banks of dynamic memory. Either X9 or X36 SIMMs are supported. CAS#-before-RAS# refresh cycles are performed periodically, as determined by the refresh timer. The DRAM controller must arbitrate between access requests and refresh requests. EDO fast page mode and parity check are also supported.

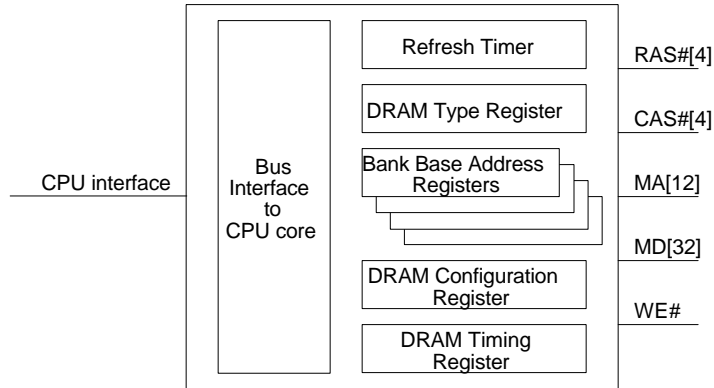

Figure 8.1 DRAM controller block diagram

For each bank of DRAM, there will be registers to specify the bank base address and the bank DRAM type:

Bank Base Address Register.

Bank Type Register.

DRAM Type Register is used to program the DRAM type of each bank.

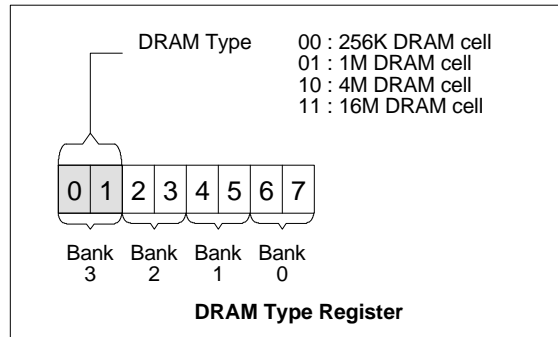

Figure 8.2 DRAM Type register programming

DRAM Timing Register is used to program DRAM timing parameters:

- 2ah [6:7] Write cycle RAS# to CAS# delay.
- [4:5] Read cycle RAS# to CAS# delay
- [3] Write cycle CAS# pulse width.
- [2] CAS# precharge time.
- [0:1] RAS# precharge time.
- 2bh [6:7] Read cycle. CAS# pulse width.
- [5] Refresh cycle. CAS# active to RAS# active delay.
- [3:4] Refresh cycle. RAS# active to CAS# inactive delay.
- [1:2] Refresh cycle. RAS# active pulse width.
- [0] Parity check enable.

DRAM configuration register is used to program the DRAM configuration:

- [7] EDO fast pagemode enable.
- [6] Fast write mode enable
- [5] Disable DRAM address range from A0000 to FFFFF
- [4] Enable DRAM bank 0.
- [3] Enable DRAM bank 1.
- [2] Enable DRAM bank 2.
- [1] Enable DRAM bank 3.

The refresh timer is a decrementing timers, which are clocked by a separated clock from the system clock. When the refresh timer reaches zero, the refresh timer will generate a DRAM refresh request.

8.1.2 ROM controller

The ROM controller also supports upto four banks of ROM and the ROM can be 8-bit, 16-bit, or 32-bit.

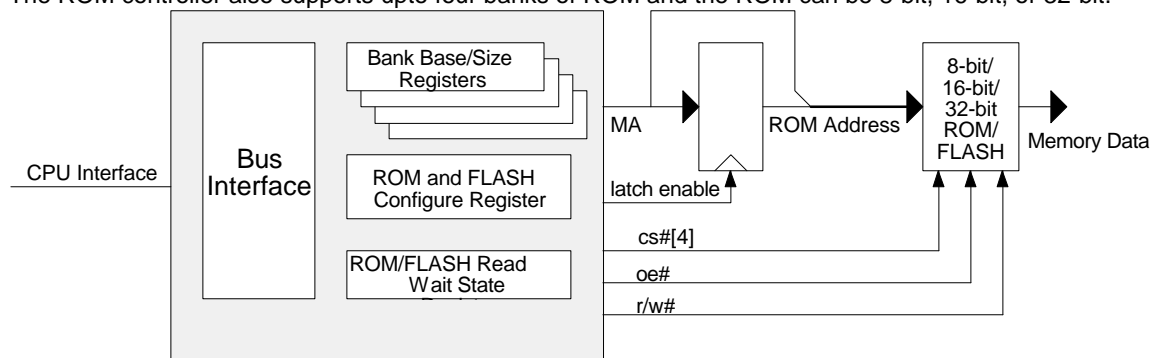

Figure 8.3 ROM controller diagram

For each bank of ROM, two registers are used to specify the bank address range:

ROM Bank Base Address Register.

ROM Bank Size Register.

ROM Configuration Register is used to program the ROM data bus size of each bank.

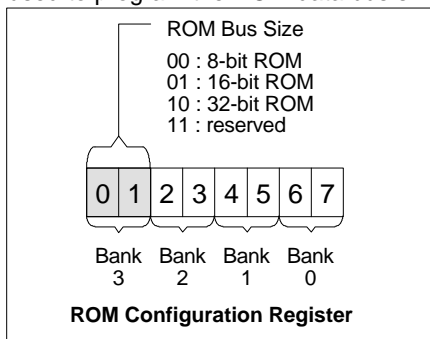

Figure 8.4 ROM configuration register programming

ROM Wait State Register is used to program the number of wait states needed to access ROM.

8.1.3 Memory controller registers

In Memory Controller, two IO ports are used to access the entire register set: the index port is at address 22h and the data port is at address 23h. To access a register, first write the index into the index port and then read or write the data through the data port. The internal register for the memory controller is listed as follows:

ROM controller register :

Index	Bit No.	Description
00h	[0:7]	ROM bank 0 base address register[0:7]
01h	[0:7]	ROM bank 0 base address register[8:15]
02h	[0:7]	ROM bank 1 base address register[0:7]

03h	[0:7]	ROM bank 1 base address register[8:15]
04h	[0:7]	ROM bank 2 base address register[0:7]
05h	[0:7]	ROM bank 2 base address register[8:15]
06h	[0:7]	ROM bank 3 base address register[0:7]
07h	[0:7]	ROM bank 3 base address register[8:15] The register 0~7 has no default value.
08h	[0:7]	[0:3] ROM bank 0 size. [4:7] ROM bank 1 size.
09h	[0:7]	[0:3] ROM bank 2 size. [4:7] ROM bank 3 size. 0XXX → disable. 1000 → 64K, 1001 → 128K, 1010 → 256K, 1011 → 512K, 1100 → 1M, 1101 → 2M, 1110 → 4M, 1111 → 16M. The default value is 0.
0ah	[0:7]	[0:1] bank 3 band width: 00 → 8_bit, 01 → 16_bit, 10 → 32_bit, 11 → reserved [2:3] bank 2 band width: 00 → 8_bit, 01 → 16_bit, 10 → 32_bit, 11 → reserved [4:5] bank 1 band width: 00 → 8_bit, 01 → 16_bit, 10 → 32_bit, 11 → reserved [6:7] bank 0 band width: 00 → 8_bit, 01 → 16_bit, 10 → 32_bit, 11 → reserved The default width of bank 0~3 is set by memory data bus bit 30 and 31.
0bh	[0:7]	[0:2] ROM access wait state. 000 → wait 2 state. 001 → wait 3 state. 010 → wait 4 state. 011 → wait 5 state. 100 → wait 6 state. 101 → wait 7 state. 110 → wait 8 state. 111 → wait 9 state. The default wait state is 8. [3] access ROM bank0 only. Default bank0 only. [4] LA mode. Default LA mode.

DRAM Controller Register

Index	Bit No.	Description
20h	[0:7]	DRAM bank 0 base address register[0:7]
21h	[0:7]	DRAM bank 0 base address register[8:11]
22h	[0:7]	DRAM bank 1 base address register[0:7]
23h	[0:7]	DRAM bank 1 base address register[8:11]
24h	[0:7]	DRAM bank 2 base address register[0:7]
25h	[0:7]	DRAM bank 2 base address register[8:11]
26h	[0:7]	DRAM bank 3 base address register[0:7]
27h	[0:7]	DRAM bank 3 base address register[8:11] The registers 20~27 has no default value.
28h	[0:7]	[0:1] DRAM bank 3 type : 00 → 256K, 01 → 1M, 10 → 4M, 11 → 16M, [2:3] DRAM bank 2 type : 00 → 256K, 01 → 1M, 10 → 4M, 11 → 16M, [4:5] DRAM bank 1 type : 00 → 256K, 01 → 1M, 10 → 4M, 11 → 16M, [6:7] DRAM bank 0 type : 00 → 256K, 01 → 1M, 10 → 4M, 11 → 16M, Default 256K type.
29h	[0:7]	[0] Parity check enable. (default 0) [1] Enable DRAM bank 3.(default 0) [2] Enable DRAM bank 2.(default 0) [3] Enable DRAM bank 1.(default 0) [4] Enable DRAM bank 0.(default 0) [5] Disable DRAM address range from A0000 to FFFFF.(default 0) [6] Fast write mode enable.(default 0) [7] EDO fast page mode enable.(default 0)

2ah	[0:7]	[0:1] RAS# precharge time.(default 0) [2] CAS# precharge time.(default 0) [3] Write cycle CAS# pulse width.(default 1) [4:5] Read cycle RAS# to CAS# delay.(default 'b01) [6:7] Write cycle RAS# to CAS# delay.(default 'b01)
2bh	[0:7]	[0:1] Refresh period. 00 : → 15us. (default). 01 : → 30us. 10 : → 60us. 11 : → disable refresh (for test only). [2] Refresh cycle. RAS# active pulse width after CAS# disactive. [3:4] Refresh cycle. RAS# active to CAS# inactive delay.(default 'b01) [5] Refresh cycle. CAS# active to RAS# active delay.(default 0) [6:7] Read cycle CAS# pulse width.(default 'b01)

8.2 DMA Controller (DMAC)

The DMAC megacell provides two DMA channels to support DMA transfers between 8-bit I/O devices and main memory. The DMA mechanism will provide two different methods for performing DMA transfers: demand-mode transfers and block-mode transfers. The DMAC hardware is responsible for synchronizing transfers with memory or external devices.

When the DMAC is configured for demand mode, an external device requests a DMA transfer with a request input (DREQ1:0#). The DMAC acknowledges the requesting device with an acknowledge signal (DACK1:0#) when the requesting device is accessed.

In block mode, DMA transfers are not requested by an external device. The DMA operation is initiated by software and continued until terminated or suspended. The DMA operation is started when the enable bit in the Configuration Register is set.

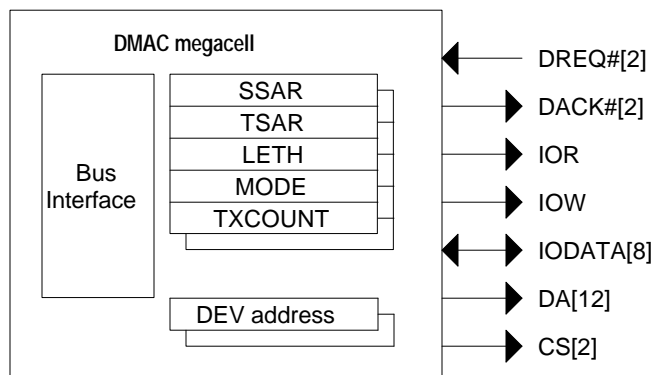

Figure 8.5 DMA controller

In programming the megacell registers, the register address is defined by the BASE register plus the offset value.

8.2.1 Register Description:

Source Starting Address Register (SSAR0=080, SSAR1=084): SSAR is a read/write 32-bit register that contains the starting address of the DMA transfer source.

Target Starting Address Register (TSAR0=081, TSAR1=085): TSAR is a read/write 32-bit register that contains the starting address of the DMA transfer target.

Length/Count Register (LETH0=082, LETH1=086): LETH is a read/write 32-bit register that records the counts of current DMA transfer.

DMA Channel Mode Register (MODE0=20c, MODE1=21c): The MODE register specifies the operation mode of each channel.

The Wait State Number specifies the number of wait state needed for the particular DMA channel.

The Recovery State Number specifies the number of wait state needed for the recovery of the DMA channel.

The channel terminal count flags indicate that a DMA operation has stopped.

The DMA channel enable bits enable or suspend a DMA operation after a channel is set up. If a enable bit for a channel is cleared when a channel is active, the DMA will be suspended after pending requests for the channel are serviced. The DMA operation will resume normally when the bit is reset.

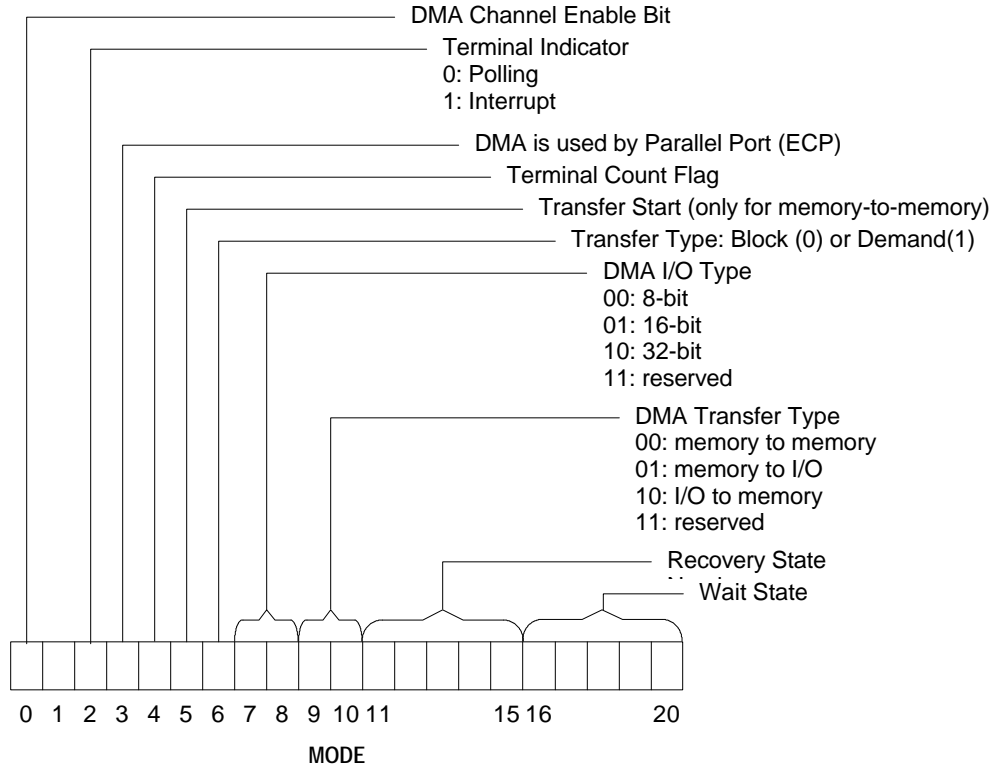

Figure 8.6 Programming DMA controller MODE register

8.3 Timer / Counter

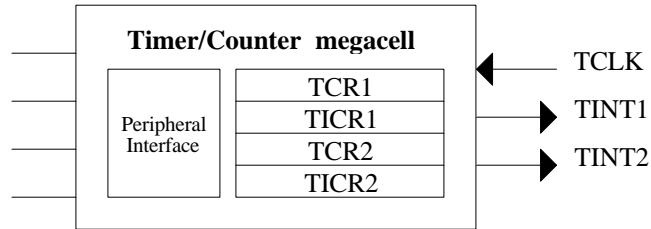
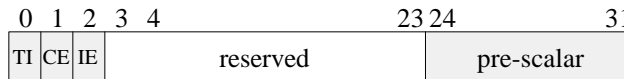

Figure 8.7 Timer/Counter Megacell

Two 24-bit decrementing timers will be implemented. When the timer's interrupt enable bit is set to one and the counter decrements to zero, the timer will assert the associated interrupt signal. The interrupt signal will assert one of the 32 external interrupts defined by the EI bits in the control register. When a timer reaches zero, the timer hardware reloads the counter with the value from the timer initial count register and continues decrementing.

Each timer is controlled and initialized by two registers: a timer control register and an timer initial count register. These registers are all memory mapped I/O registers.

Timer Control register:



TCR

Pre-Scalar (PS): A pre-scalar value can be used to divide the input clock.

Interrupt Enable bit (IE): When IE is set to one and the counter decrements to zero, the timer asserts its interrupt signal to interrupt the CPU.

Counter Enable bit (CE): Setting the CE bit to one causes the timer to begin decrementing. Setting the CE bit to zero stops the timer.

Timer Interrupt bit (TI): The timer sets this bit to one to indicate that it has decrement to zero. This bit remain one until software sets it to zero.

Timer Initial Count Register:



TICR

A 24-bit read/write register for the initial counter value.

8.4 Serial I/O

The serial I/O megacell implements a full-duplex, bi-directional UART with FIFO.

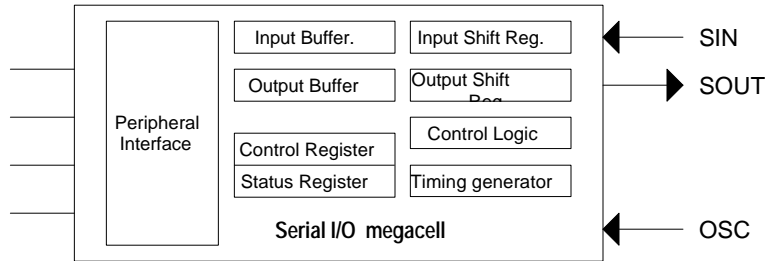

Figure 8.8 Serial I/O with FIFO

8.4.1 UART Register Definition

			Description
0	3F8, DLAB = 0	RBR[0:7]	- Receiver Buffer Register. - Read only. - bit 7 is LSB.
0	3F8, DLAB = 0	THR[0:7]	- Transmitter Holding Register. - Write only. - bit 7 is LSB.
1	3F9, DLAB = 0	IER[3:7]	- Interrupt Enable Register. * bit 7: Irpt_RDA enable (1/0- Enable/Disable). * bit 6: Irpt_THRE enable (1/0- Enable/Disable). * bit 5: Irpt_RLS enable (1/0- Enable/Disable). * bit 4: Irpt_MOS enable (1/0- Enable/Disable). - bit 3: Loop-back enable (1/0- Enable/Disable).
0	3F8, DLAB = 1	DLL[0:7]	* Divisor Latch Register (LS).
1	3F9, DLAB = 1	DLM[0:7]	* Divisor Latch Register (MS).
2	3FA	IIR[0:7]	- Interrupt Ident. Register. - Read only. * bit 7: No Irpt pending (1/0- True/False). * bit 6: Irpt ID bit (2). * bit 5: Irpt ID bit (1). * bit 4: Irpt ID bit (0). - bit 3: DMA mode select (1/0- Mode 1/Mode 0). - bit 2: RCVR trigger (LSB). - bit 1: RCVR trigger (MSB). - bit 0: FIFO mode enable (1/0- Enable/Disable).

2	3FA	FCR[0:7]	<ul style="list-style-type: none"> - FIFO Control Register. - Write only. * bit 7: FIFO mode enable (1/0- Enable/Disable). - bit 6: Reset RCVR FIFO. (self_clearing bit) - bit 5: Reset XMIT FIFO. (self_clearing bit) - bit 4: DMA mode select (1/0- Mode 1/Mode 0). - bit 3: (Reserve). - bit 2: (Reserve). * bit 1: RCVR trigger (LSB). * bit 0: RCVR trigger (MSB).
3	3FB	LCR[0:7]	<ul style="list-style-type: none"> - Line Control Register. * bit 7: Word length select (LSB). * bit 6: Word length select (MSB). - bit 5: Number of stop bit. - bit 4: Parity enable. (1/0- Enable/Disable) - bit 3: Even parity select. (1/0- Even/Odd parity) - bit 2: Stick parity enable. (1/0- Enable/Disable) - bit 1: Set break. - bit 0: Divisor Latch Access Bit (DLAB).
4	3FC	TOR[0:7]	<ul style="list-style-type: none"> - Time Out Register. - bit 7 ~ 1: Time out bit-count. - bit 0: Irpt_TOUT enable. (1/0- Enable/Disable)
5	3FD	LSR[0:7]	<ul style="list-style-type: none"> - Line Status Register. - Read only. - Write: Null operation. - bit 7: Data Ready (DR). - bit 6: Overrun Error (OE). - bit 5: Parity Error (PE). - bit 4: Framing Error (FE). - bit 3: Break Interrupt (BI). - bit 2: THR Empty (THRE). - bit 1: Transmitter Empty (TEMT). - bit 0: Error in RCVR FIFO (Err_RCVR).
6	3FE	MOS[0:7]	<ul style="list-style-type: none"> - MODEM Status Register: non-exist - Write: Null operation. - Read: Get 8'b0
7	3FF	SCR[0:7]	<ul style="list-style-type: none"> - Scratchpad Register. - Read/Write-able

Note: 1. Irpt_RDA: Received Data Available interrupt.
 Irpt_THRE: Transmitter Holding Register Empty interrupt.
 Irpt_RLS: Receiver Line Status Interrupt.
 Irpt_MOS: MODEM Status Interrupt.
 Irpt_TOUT: Receiver Time OUT Interrupt.

2. Baud rate = Frequency input / (16 * ((DLM, DLL} + 2))

3. Interrupt Identification:

IIR[4]	IIR[5]	IIR[6]	IIR[7]	Priority	Irpt type
-	-	-	1	-	None
0	0	0	0	4th	Irpt_MOS
0	0	1	0	3rd	Irpt_THRE
0	1	0	0	2nd	Irpt_RDA
1	1	0	0	2nd	Irpt_TOUT
0	1	1	0	1st	Irpt_RLS

- * Irpt_RLS- caused by: Overrun Error or Parity Error or Framing Error or Break Interrupt.
- reset by: Reading LSR.
- * Irpt_RDA- caused by: Received data \geq RCVR trigger level.
- reset by: Reading RBR or RCVR FIFO drops below the trigger level.
- * Irpt_TOUT- caused by: RCVR FIFO is non-empty and have not been accessed (Read/write) for the time \geq TOUR[1:7].
- reset by: Reading RBR.
- * Irpt_THRE- caused by: THRE has been set.
- reset by: Reading IIR (if source of INTR is Irpt_THRE) or writing THR.
- * Irpt_MOS- MODEM Status interrupt: Non-implemented.

4. RCVR Interrupt trigger level programing:

FCR[0]	FCR[1]	Trigger level
0	0	1 bytes
0	1	4 bytes
1	0	8 bytes
1	1	14 bytes

5. FCR[7] is always 1. Write FCR[7] to 0 has no effect.

6. Transmitter/Receiver Character length programing:

LCR[6]	LCR[7]	Character length
0	0	5 bits
0	1	6 bits
1	0	7 bits
1	1	8 bits

8.5 Parallel Port

The parallel port megacell implements the IEEE 1284 parallel port. The IEEE 1284 standard provides for high speed bi-directional communication between the PC and an external peripheral.

The parallel port defines 5 modes of data transfer. Each mode provides a method of transferring data in either the forward direction, reverse direction, or bi-directional data transfer. The defined modes are:

- Standard parallel port mode
- PS/2 parallel port mode
- Parallel port FIFO mode
- ECP parallel port mode
- Centronix Peripheral mode (Vendor specified mode)

Other modes defined in the IEEE 1284 standard like test mode and configuration mode are also supported.

8.5.1 ECP Register Description

1. Data Register (offset 378) R/W

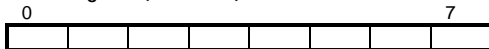

This is the standard parallel port data register. Writing to this register in Standard mode shall drive data to the parallel port data lines. In all other modes the drivers may be tri-stated by setting the direction bit in the dcr register. Read to this register return the value on the data lines.

Standard mode:

write data_reg: cpu_data[0:7]→ data_reg[0:7]→ PAD_ED[0:7]

read data_reg: data_reg[0:7]→ cpu_data

PS/2 mode, forward:

write data_reg: cpu_daa → data_reg → PAD_ED

read data_reg: data_reg→ cpu_data

PS/2 mode, reverse:

write data_reg: cpu_data→ data_reg

read data_reg: PAD_ED→ cpu_data

Centronix Peripheral mode:

read data_reg: PAD_ED→ cpu_data

Other mode:

write data_reg: cpu_data[0:7]→ data_reg[0:7]

read data_reg: undefined

2. DSR register (offset 379) Read only

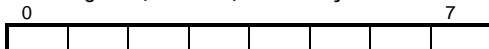

This read-only register reflects the inputs on the parallel port interface.

Bit [0]- nBusy: inverted parallel portBusy signal

Bit [1]- nAck: parallel portnAck signal

Bit [2]- PError: parallel portPError signal

Bit [3]- Select: parallel portSelect signal

Bit [4]- nFault: parallel portnFault signal

Bit [5:7]- reserved

3. DCR register (offset 37a) R/W

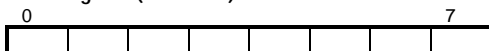

This register directly controls several output signals as well as enabling some functions. The drivers for nStroke, nAutoFd, nInIt, and nSelectIn are open-collector in standard mode.

Bit [0:1]- reserved

Bit [2]- Direction

0: forward (default)

Drivers are enabled.

1: reserved

In Standard mode or Parallel FIFO mode, this bit is forced to 0. The drivers are enabled, i.e. the data pins of the parallel port are always outputs. Otherwise, this bit tri-states the data output drivers, so that data will be read from the peripheral.

Bit [3]- ackIntEn

- 1: Enable an interrupt on the rising edge of nAck.
- 0: Disable the nAck interrupt (default)

Bit [4]- SelectIn; is inverted and then driven as parallel port nSelectIn (default 1).

Bit [5]- nInIt; is driven as parallel port nInIt (default 1).

Bit [6]- autoFd; is inverted and then driven as parallel port nAutoFd (default 0).

In centronic peripheral mode, when the nAck is active, the bit will be cleared by hardware.

Bit [7]- strobe; is inverted and then driven as parallel port nStrobe (default 0).

4. ECR register (offset 243) (R/W)

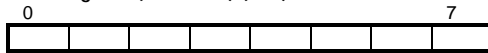

Bit[0:2]- mode (R/W)

000: Standard parallel port mode (default).

In this mode, FIFO is reset and common collector drivers are used on the control lines (nStrobe, nAutoFd, nInIt, and nSelectIn). Direction bit is cleared to "0".

001: PS/2 parallel port mode

The direction could be forward or reverse. In reverse direction, reading the data register returns the value on the data lines not the value in the data register.

010: Parallel port FIFO mode

This is the same as Standard parallel port mode except that Pwords are written or DMAed to the FIFO. FIFO data is automatically transmitted using the standard parallel port protocol. Note that this mode is only useful when the direction bit is 0.

011: ECP parallel port mode

In the forward direction, Pwords is placed into the FIFO and transmitted automatically to the peripheral using ECP protocol. In the reverse direction, bytes are moved from the ECP data port and packed into Pwords in the FIFO. All drivers have active pull-ups.

100: Centronic peripheral mode

In this mode, the parallel port acts as a reverse port in centronics mode and the direction bit is forced to 1. The nAutoFd bit (DCR bit 6) is cleared, nAck is active until nAutoFd bit (DCR bit 6) is set to 1 by software. And the parallel port data will be latched in the data register.

101: Reserved

110: Test mode

In this mode, the FIFO may be read or written, BUT the data will not be transmitted on the parallel port. Using this mode to test the depth of the FIFO, the write-threshold, and the read-threshold.

111: Configuration mode

In this mode, the CNFGA and CNFGB registers are accessible at addresses 244 and 246

Bit[3]- nErrIntrEn (R/W, Valid only in ECP mode)

1: Disable the interrupt generated on the asserting edge of nFault (default).

0: Enables an interrupt pulse on the high to low edge of nFault.

Note that an interrupt pulse will be generated if nFault is asserted and this bit is written from a "1" to a "0". This prevents interrupts from being lost in the time between the read of the ecr and the write of the ecr.

Bit[4]- dmaEn (R/W)

1: Enables DMA, DMA starts when serviceIntr (bit 5) is 0.

0: Disables DMA unconditionally (default).

Bit[5]- serviceIntr (R/W)

1: Disables DMA and all of the service interrupts (default).

0: Enables one of the following 3 cases of interrupts. Once one of the 3 service interrupts has occurred, serviceIntr bit shall be set to a "1" by the hardware. Writing this bit to a "1" will not cause an interrupt.

case 1: dmaEn = 1

During DMA (this bit is set to a 1 when terminal count is reached)

case 2: dmaEn = 0, direction = 0

This bit shall be set to 1 whenever there are writeIntrThreshold or more Pwords free in the FIFO.

case 3: dmaEn = 0, direction = 1

This bit shall be set to 1 whenever there are readIntrThreshold or more valid Pwords to be read from FIFO.

Bit[6]- Full (Read only)

- 1: direction = 0 The FIFO cannot accept another Pword.
- 1: direction = 1 The FIFO is completely full.
- 0: direction = 0 The FIFO has at least 1 free Pword
- 0: direction = 1 The FIFO has at least 1 free byte.

Bit[7]- empty (Read only)

- 1: direction = 0 The FIFO is completely empty
- 1: direction = 1 The FIFO contains less than 1 Pword of data
- 0: direction = 0 The FIFO contains at least 1 byte of data
- 0: direction = 1 The FIFO contains at least 1 Pword of data

5. CONFIGA register (offset 244) (R/W only in configuration mode)



Bit [0]- Indicates if interrupts are pulsed or level (Read only)

- 0: pulse
- 1: level

Bit [1:3]- Pword size (R/W)

- 001: Pword size = 1 byte
- 010: Pword size = 4 byte
- 000 and 011 ~ 111: reserved

Bit [4]- reserved

Bit [5]- nByteInTransceiver (Read only)

- 0: When transmitting (at host recovery), there is one byte in the transceiver waiting to be transmitted that does not affect the FIFO full bit.

Bit [6:7]- Snapshot of the Pword

This field is not used for Pword size of 1 byte.

For host recovery situations these bits indicate what fraction of a Pword was not transmitted so that software can re-transmit the unsent bytes. If the Pword size is 4 bytes the value of these two bits is a snapshot of the last Pword being transmitted in mode 011 event 35 when the FIFO was reset (port was transitioned from mode 011 to mode 000 or 001)

- 00- the Pword at the head of the FIFO contained a complete Pword
- 01- the Pword at the head of the FIFO contained only 1 valid bytes.
- 10- the Pword at the head of the FIFO contained 2 valid bytes.
- 11- the Pword at the head of the FIFO contained 3 valid bytes.

6. Reverse address register (offset 245) (Read only)

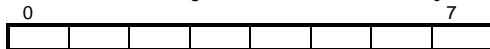

Bit [0:1]- Reserved

Bit [2]- Tag_all

- 1: To indicate the unread bytes of the FIFO storing the reverse data/ command that has at least one address bytes.
- 0: There is no address byte in the FIFO

Bit [3:6]- Tag0, Tag1, Tag2, Tag3

to check if there is one byte of the following read Pword = 4 bytes is the reverse address. Tag0, Tag1, Tag2 and Tag3 are individually for the byte0, byte1, byte2 and byte3 of the Pword

Bit [7]- Tag

to check if the byte of the following read Pword (1 byte) is the reverse address.

9. Timing Diagram

9.1 Memory controller

9.1.1 DRAM AC Timing

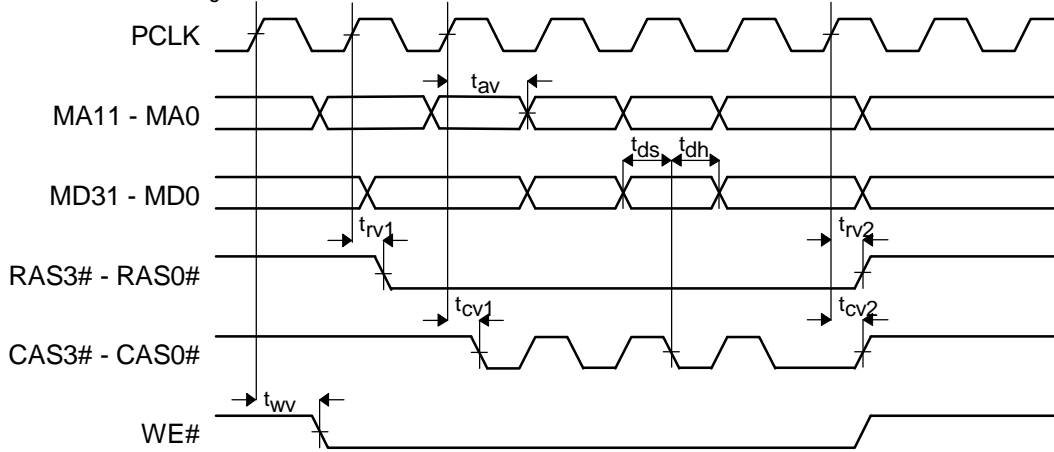

Symbol	Parameter	Min	Max	Unit
t_{rv1}	RAS# valid delay ref. to PCLK rising			ns
t_{rv2}	RAS# valid delay ref. to PCLK rising			ns
t_{cv1}	CAS# valid delay ref. to PCLK rising			ns
t_{cv2}	RAS# valid delay ref. to PCLK rising			ns
t_{wv}	WE# valid delay ref. to PCLK rising			ns
t_{ds}	Memory data setup time			ns
t_{dh}	Memory data hold time			ns
t_{av}	Memory address valid delay			ns

9.1.2 ROM AC Timing

9.1.2.1 Flash ROM Write Timing

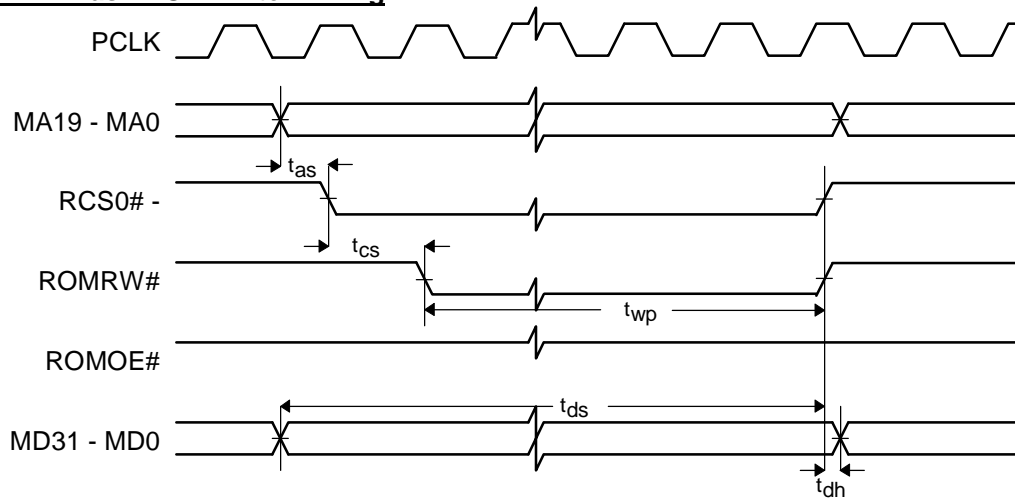

Symbol	Parameter	Min	Max	Unit
t_{as}	Address setup time			ns

t_{CS}	Chip select setup time			ns
t_{ds}	Data setup time			ns
t_{dh}	Data hold time			ns
t_{WD}	Flash ROM write pulse width		7	PCLK

9.1.2.2 ROM Read Timing

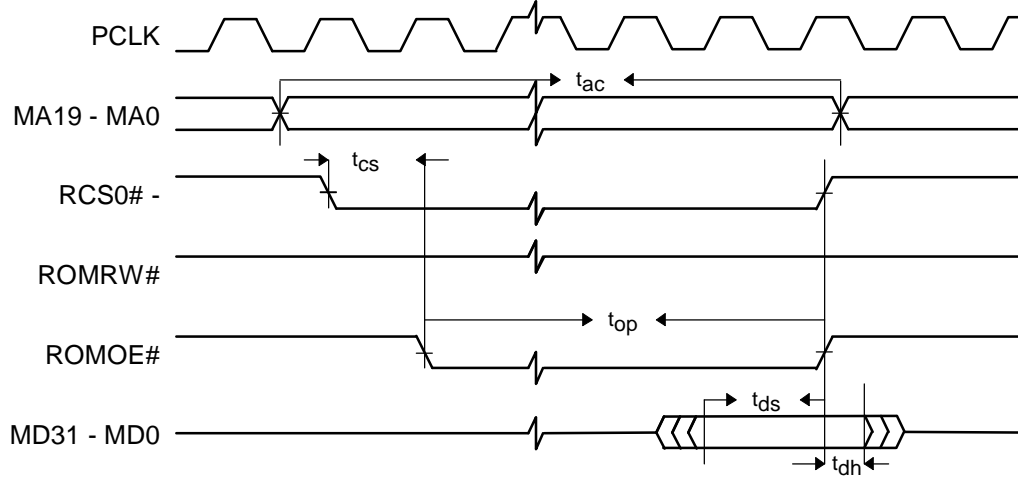

Symbol	Parameter	Min	Max	Unit
t_{ac}	Access time	3		PCLK
t_{cs}	Chip select setup time			ns
t_{op}	Output enable pulse			ns
t_{ds}	Data setup time			ns
t_{dh}	Data hold time			ns

9.2 DMA Controller

9.2.1 DMA device register read timing

DMA device register read timing

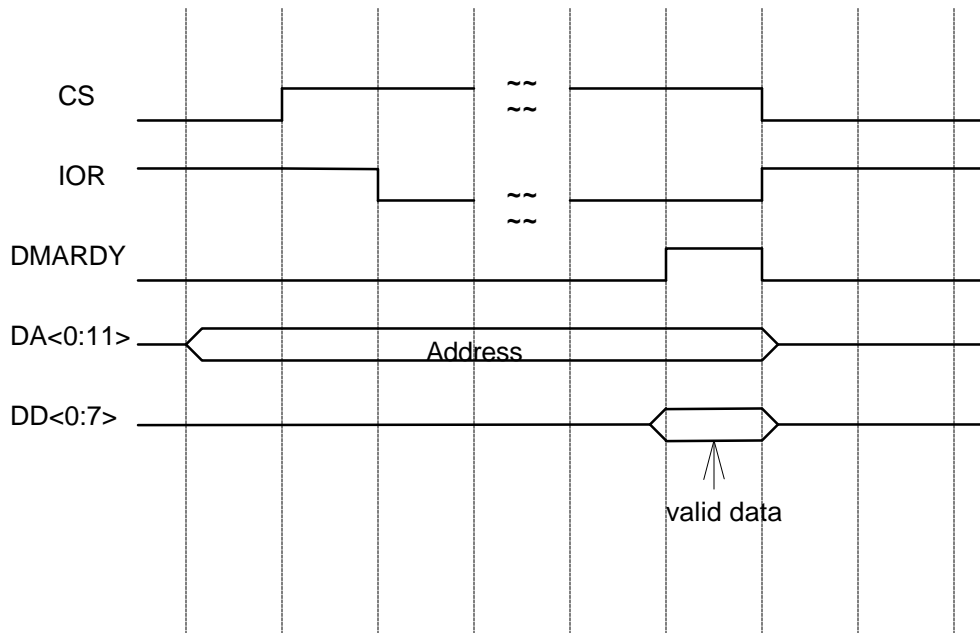

9.2.2 DMA device register write timing
DMA device register write timing

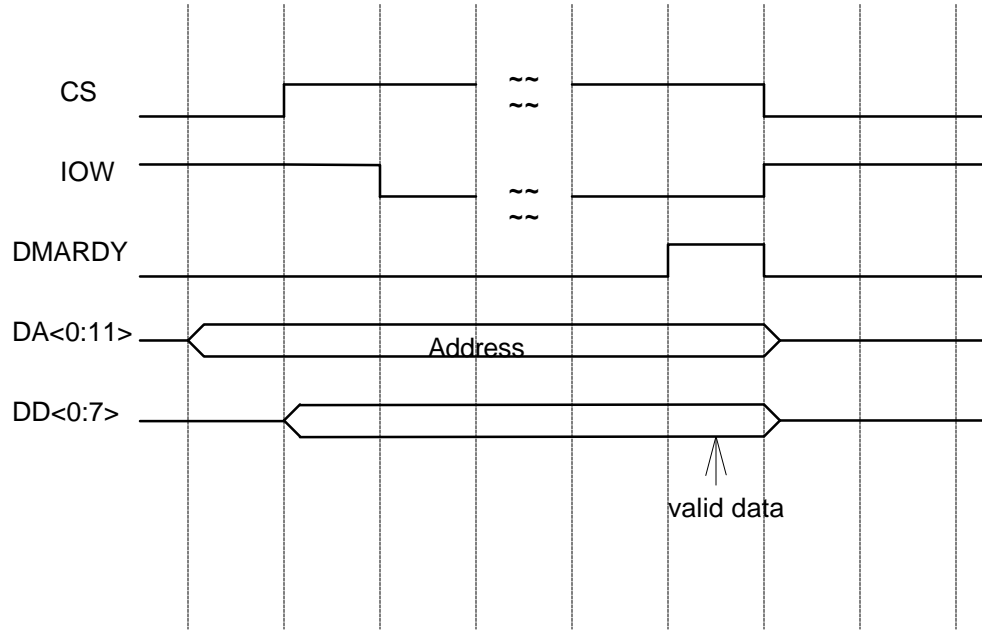

9.2.3 DMA demand mode data read cycles

DMA cycle -- data read timing (demand mode)

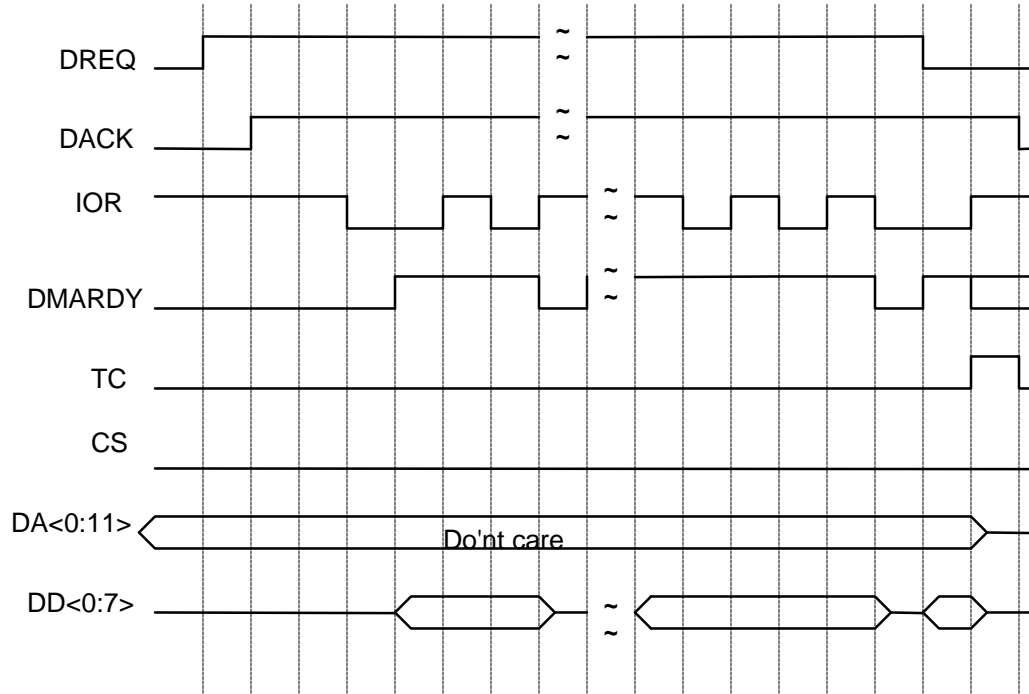

9.2.4 DMA demand mode data write cycles
 DMA cycle -- data write timing (demand mode)

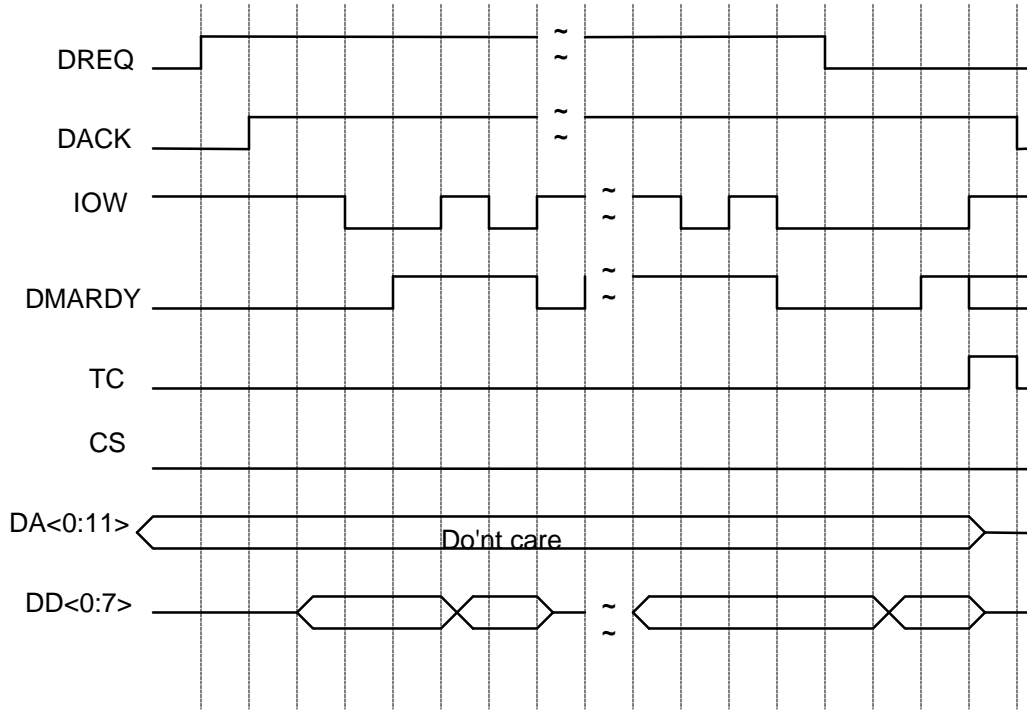

9.2.5 DMA block mode data read cycles
DMA cycle -- data read timing (block mode)

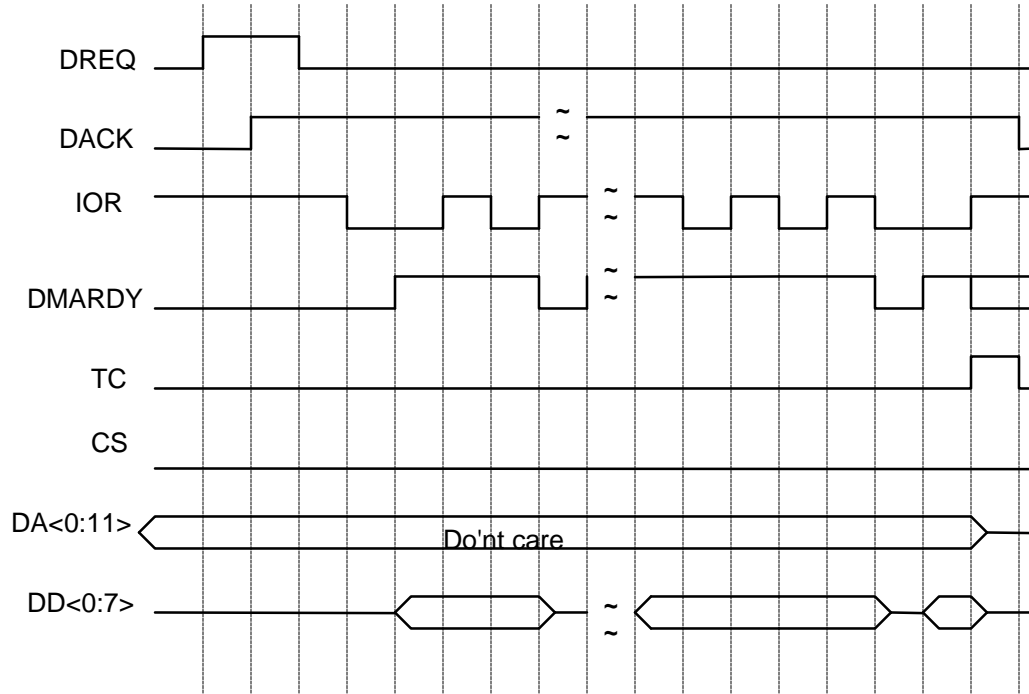

9.2.6 DMA block mode data write cycles
 DMA cycle -- data write timing (block mode)

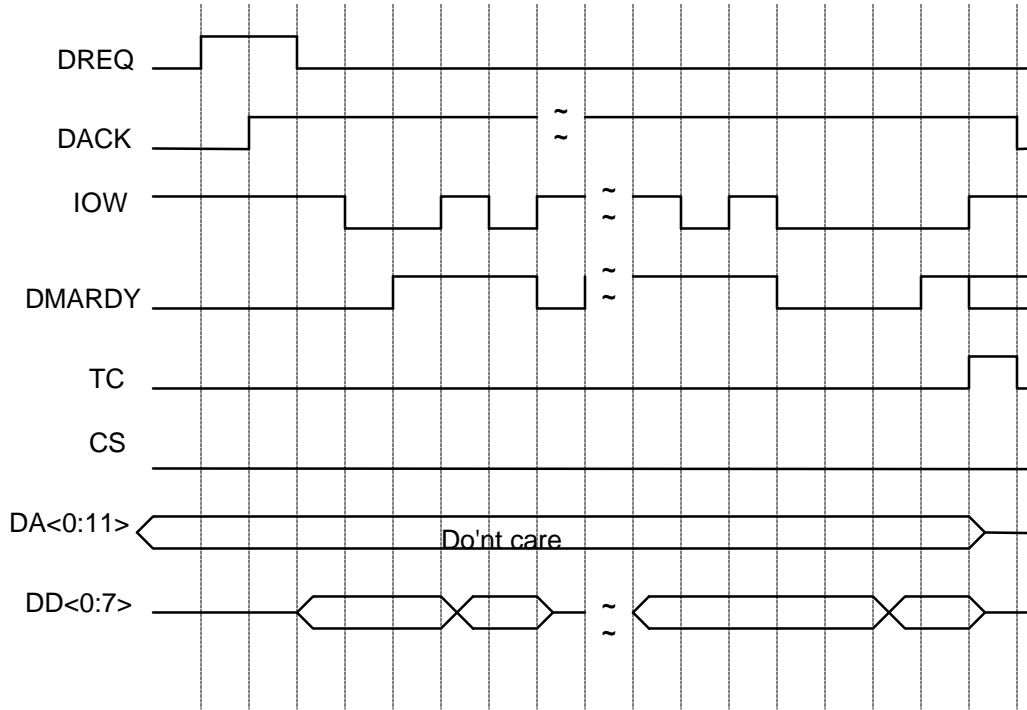

ROM/FLASH Read timing

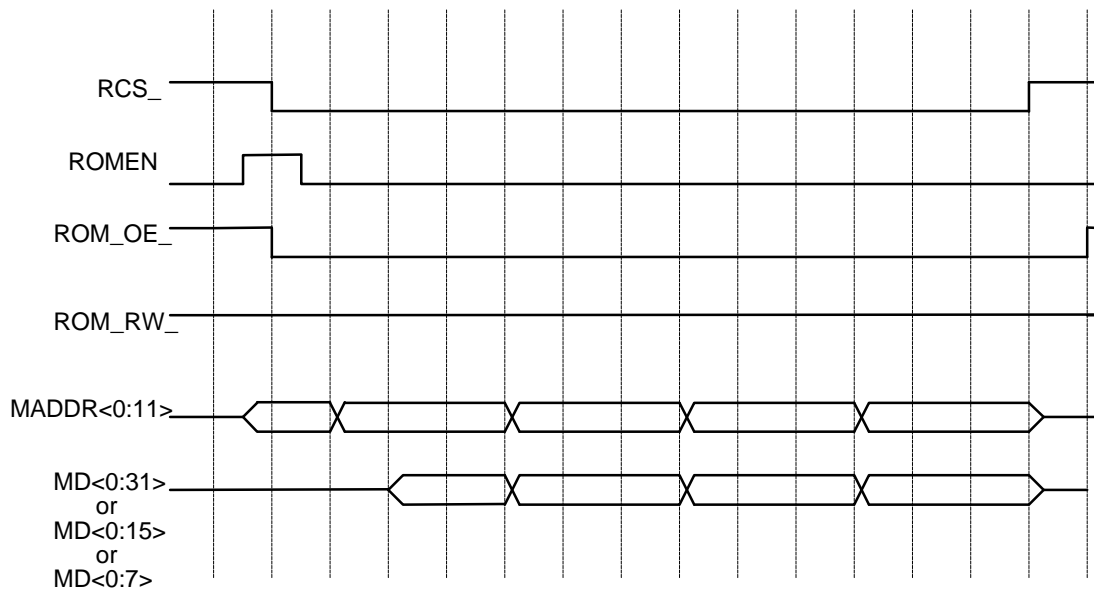

FLASH Write timing

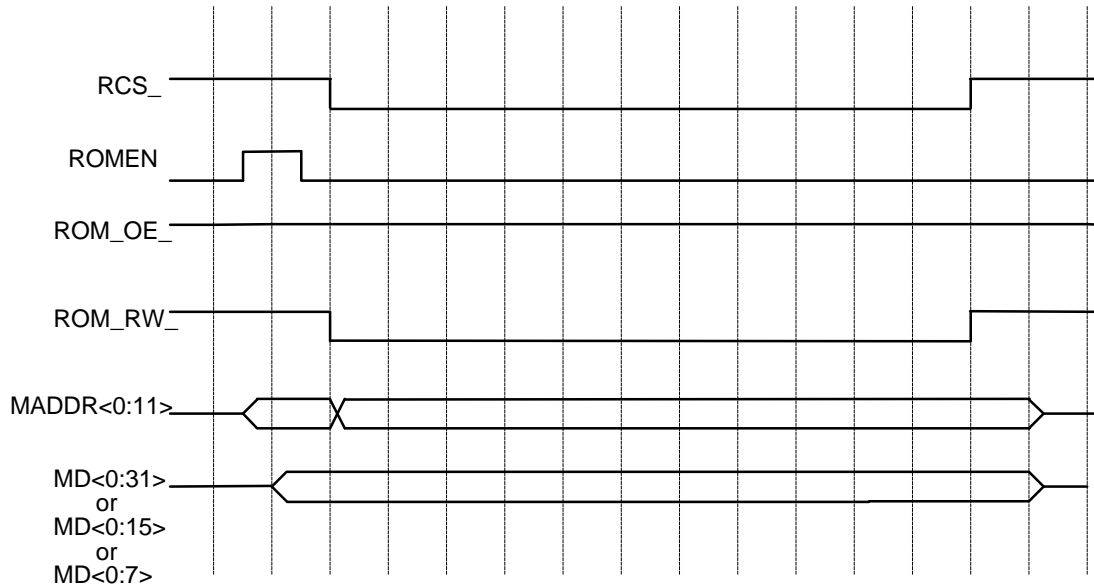

Appendix A. PA-RISC Multimedia Instruction Set

Halfword parallel add

HADD

Format: HADD, cmplt r1,r2,t

0:5	5:10	11:15			26	27:31
02	r2	r1	0	0	3	sat 0
6	5	5	3	1	4	2 1 5

Purpose: To add multiple pairs of halfwords in parallel with optional saturation.

Description: The corresponding halfwords of GR r1 and GR r2 are added together in parallel. Optional saturation is performed, which forces each halfword result to either the maximum or the minimum value, if the result would have been out of the range of the target format. The halfword results are placed in GR t.

The completer, cmplt, determines whether modular, signed-saturation, or unsigned-saturation arithmetic is performed. When no completer is specified (sat=3) modular arithmetic is performed. The completer "ss" (sat=1) designates signed saturation. The completer "us" (sat=0) indicates unsigned saturation. For signed saturation, all operands are treated as signed numbers, and the results are signed numbers. For unsigned saturation, the first operands, from GR r1, are treated as unsigned numbers, the second operands, from GR r2, are treated as signed numbers, and the results are unsigned numbers.

Operation: $GR[t]\{0..15\} \leftarrow GR[r1]\{0..15\} + GR[r2]\{0..15\};$
 $GR[t]\{16..31\} \leftarrow GR[r1]\{16..31\} + GR[r2]\{16..31\};$
 switch (cmplt) {
 case ss: if (max_signed_sat_L) /* sat=1 */
 $GR[t]\{0..15\} \leftarrow 0x7FFF;$
 else if (min_signed_sat_L)
 $GR[t]\{0..15\} \leftarrow 0x8000;$
 if (max_signed_sat_R)
 $GR[t]\{16..31\} \leftarrow 0x7FFF;$
 else if (min_signed_sat_R)
 $GR[t]\{16..31\} \leftarrow 0x8000;$
 break;
 case us: if (max_unsigned_sat_L) /* sat=0 */
 $GR[t]\{0..15\} \leftarrow 0xFFFF;$
 else if (min_unsigned_sat_L)
 $GR[t]\{0..15\} \leftarrow 0x0000;$
 if (max_unsigned_sat_R)
 $GR[t]\{16..31\} \leftarrow 0xFFFF;$
 else if (min_unsigned_sat_R)
 $GR[t]\{16..31\} \leftarrow 0x0000;$
 break;
 default: break; /* sat=3 */
 break;
 }
 }

Exceptions: None.

Halfword parallel subtract
HSUB

Format: HSUB,cmplt r1,r2,t

0:5	5:10	11:15			26	27:31
02	r2	r1	0	0	1	sat 0 t
6	5	5	3	1	4	2 1 5

Purpose: To subtract multiple pairs of halfwords in parallel with optional saturation.

Description: The corresponding halfwords of GR r2 are subtracted from the halfwords of GR r1 in parallel. Optional saturation is performed, which forces each halfword result to either the maximum or the minimum value, if the result would have been out of the range of the target format. The halfword results are placed in GR t.

The completer, cmplt, determines whether modular, signed-saturation, or unsigned-saturation arithmetic is performed. When no completer is specified (sat=3) modular arithmetic is performed. The completer "ss" (sat=1) designates signed saturation. The completer "us" (sat=0) indicates unsigned saturation. For signed saturation, all operands are treated as signed numbers, and the results are signed numbers. For unsigned saturation, the first operands, from GR r1, are treated as unsigned numbers, the second operands, from GR r2, are treated as signed numbers, and the results are unsigned numbers.

Operation: $GR[t]\{0..15\} \leftarrow (GR[r1]\{0..15\} + - GR[r2]\{0..15\} + 1)$;
 $GR[t]\{16..31\} \leftarrow (GR[r1]\{16..31\} + - GR[r2]\{16..31\} + 1)$;
 switch (cmplt) {

```

    case ss:          if (max_signed_sat_L)                               /* sat=1 */
                      GR[t]{0..15} ← 0x7FFF;
                      else if (min_signed_sat_L)
                      GR[t]{0..15} ← 0x8000;
                      if (max_signed_sat_R)
                      GR[t]{16..31} ← 0x7FFF;
                      else if (min_signed_sat_R)
                      GR[t]{16..31} ← 0x8000;
                      break;
    case us:          if (max_unsigned_sat_L)                             /* sat=0 */
                      GR[t]{0..15} ← 0xFFFF;
                      else if (min_unsigned_sat_L)
                      GR[t]{0..15} ← 0x0000;
                      if (max_unsigned_sat_R)
                      GR[t]{16..31} ← 0xFFFF;
                      else if (min_unsigned_sat_R)
                      GR[t]{16..31} ← 0x0000;
                      break;
    default:          break;                                             /* sat=3 */
  }

```

Exceptions: None.

Halfword parallel average
HAVE

Format: HAVE r1,r2,t

0:5	5:10	11:15	26	27:31
02	r2	r1	0 0	0b 0 t
6	5	5	3 1	6 1 5

Purpose: To average multiple pairs of halfwords in parallel.

Description: The corresponding halfwords of GR r1 and GR r2 are averaged in parallel. Both operands are unsigned. The average is obtained by adding the corresponding halfwords, and shifting the result right by one bit, to perform a divide by 2, with the halfword carry bit from the addition shifted back into the leftmost position of each result. The halfword results are placed in GR t.

Unbiased rounding is performed on the result of summation, to reduce the accumulation of rounding errors with cascaded operations.

Operation:

```

cat(carry_L, sum{0..15}) ← GR[r1]{0..15} + GR[r2]{0..15}
cat(carry_R, sum{16..31}) ← GR[r1]{16..31} + GR[r2]{16..31}
new_lsb_L ← sum{14} | sum{15};                               /* unbiased rounding */
new_lsb_R ← sum{30} | sum{31};                               /* unbiased rounding */
GR[t]{0..15} ← cat(carry_L, sum{0..13}, new_lsb_L);
GR[t]{16..31} ← cat(carry_L, sum{16..29}, new_lsb_R);
  
```

Exceptions: None.

Halfword parallel shift left and add
HSHLADD

Format: HSHLADD r1,k,r2,t or HSL1ADD r1,r2,t
 HSL2ADD r1,r2,t
 HSL3ADD r1,r2,t

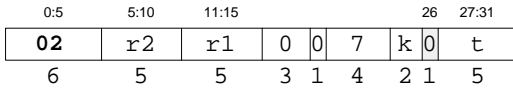

Purpose: To perform multiple pairs of halfword shift left and add operations in parallel with saturation.

Description: Each halfword of GR r1 is shifted left by k bits, and then added to the corresponding halfword of GR r2. Signed saturation is performed on the addition, which forces each halfword result to either the maximum or the minimum value, if the result would have been out of range. The halfword results are placed in GR t. The shift amount is either 1, 2, or 3, and is encoded in the k field of the instruction.

All operands are treated as signed numbers, and the results are signed numbers. Signed saturation is performed.

For this instruction, signed saturation is based both on the shift operation and the add operation. That is, if the result of the shift operation is not representable in 16 bits, signed saturation occurs. If GR r1 was positive, maximum saturation occurs. If GR r1 was negative, minimum saturation occurs. If the result of the shift operation is representable in 16 bits, then saturation is determined by the add operation in the normal fashion.

Operation: $GR[t]\{0..15\} \leftarrow \text{lshift}(GR[r1]\{0..15\},k) + GR[r2]\{0..15\};$
 $GR[t]\{16..31\} \leftarrow \text{lshift}(GR[r1]\{16..31\},k) + GR[r2]\{16..31\};$
 if (max_signed_sat_L)
 $GR[t]\{0..15\} \leftarrow 0x7FFF;$
 else if (min_signed_sat_L)
 $GR[t]\{0..15\} \leftarrow 0x8000;$
 if (max_signed_sat_R)
 $GR[t]\{16..31\} \leftarrow 0x7FFF;$
 else if (min_signed_sat_R)
 $GR[t]\{16..31\} \leftarrow 0x8000;$

Exceptions: None.

Halfword parallel shift right and add

Format: HSHRADD r1,k,r2,t or

HSR1ADD r1,r2,t

HSR2ADD r1,r2,t

HSR3ADD r1,r2,t

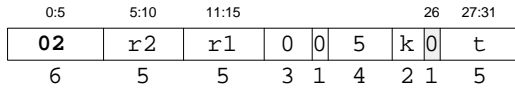
HSHRADD

Purpose: To perform multiple pairs of halfword shift right and add operations in parallel with saturation.

Description: Each halfword of GR r1 is shifted right by k bits, and then added to the corresponding halfword of GR r2. The bits shifted into each halfword, from the left, are the same as the sign bit for each halfword. Signed saturation is performed on the addition, which forces each halfword result to either the maximum or the minimum value, if the result would have been out of range. The halfword results are placed in GR t. The shift amount is either 1, 2, or 3, and is encoded in the k field of the instruction.

All operands are treated as signed numbers, and the results are signed numbers. Signed saturation is performed.

Operation:

$$GR[t]\{0..15\} \leftarrow \text{arshift}(GR[r1]\{0..15\},k) + GR[r2]\{0..15\};$$

$$GR[t]\{16..31\} \leftarrow \text{arshift}(GR[r1]\{16..31\},k) + GR[r2]\{16..31\};$$

if (max_signed_sat_L)
 $GR[t]\{0..15\} \leftarrow 0x7FFF;$
 else if (min_signed_sat_L)
 $GR[t]\{0..15\} \leftarrow 0x8000;$
 if (max_signed_sat_R)
 $GR[t]\{16..31\} \leftarrow 0x7FFF;$
 else if (min_signed_sat_R)
 $GR[t]\{16..31\} \leftarrow 0x8000;$

Exceptions: None.

Appendix B. Diagnostic Instructions

HALT

Format: **HALT**

0:5	5:10	11:15	21:25	26	27:31
05	-	-	-	-	10
6	5	5	2	3	5

Purpose:

To halt instruction pipeline and entry ICE single-step mode.

Description:

The HALT instruction clears instruction pipeline. Any unfinished bus cycle and internal I/D-cache operation will be cleared before CPU entering single-step mode.

Operation:

Enforce CPU clear pipeline and entry single-step mode;

Note:

This instruction can be executed by code running at any privileged level. (different from other diagnostic instr.)

Move to AIR
MTAIR

Format: MTAIR r,t

0:5	5:10	11:15	21:25	26	27:31
05	t	r	-	-	00
6	5	5	2	3	5 1 5

Purpose: To copy value into a specified AIR from a general register.

 Description: If the AIR[t] is existed, the contents of GR[r] is copied into AIR[t]. If AIR[t] has n bits where $n \leq 32$, the least significant n bits of GR[r] are moved into AIR[t].

 Operation: if(t > 6)

- undefined operaton;
- else if(priv != 0)
 - privilege instruction trap;
- else
 - AIR[t] <-- GR[r];

Exception: Privilege instruction trap.

Restriction: This instruction can be executed only by code running at the most privileged level.

 Notes: AIR[0]: Internal configuration register

- bit31: Internal I-Cache enable (0/1- disable/enable)
- bit30: Internal D-Cache enable (0/1- disable/enable)
- bit29: Burst write enable (0/1- disable/enable)
- bit28: Default endian bit (0/1- big/little endian)
- bit27: Trap step mode enable (0/1- disable/enable)
- bit26: reserved
- bit25: reserved
- bit24: Enter Sleep state
- bit23: Multiplier wait state (0/1- 0/1 wait state)
- bit22: Freeze 1st 1K of I-Cache (0/1- disable/enable)
- bit21: Freeze 2nd 1K of I-Cache (0/1- disable/enable)
- bit20: Freeze 3rd 1K of I-Cache (0/1- disable/enable)
- bit19: Freeze 4th 1K of I-Cache (0/1- disable/enable)

 (default: 13'b0)

- AIR[1]: PSW register (default: 32'h0)
- AIR[2]: TMR (timer register)
- AIR[3]: Non-cacheable Offset register
- AIR[4]: Non-cacheable Mask register
- AIR[5]: Write-Through Offset register
- AIR[6]: Write-Through Mask register
- AIR[7]: PCO register (program counter)

Move from AIR
MFAIR

Format: MFAIR r,t

0:5	5:10	11:15	21:25	26	27:31
05	r	-	-	-	01 - t
6	5	5	2	3	5 1 5

Purpose: To copy value into a general register from AIR register.

 Description: If the AIR[r] is existed, the contents of AIR[r] is copied into GR[t]. If AIR[r] has only n bits where $n \leq 32$, the least significant n bits of AIR[r] are moved into GR[t] and the others are zero.

 Operation:

```

if(t > 6)
    undefined operation;
else if(priv != 0)
    privilege instruction trap;
else
    GR[t] <-- AIR[r];
  
```

Exception: Privilege instruction trap.

Restriction: This instruction can be executed only by code running at the most privileged level.

 Notes:

- AIR[0]: Internal configuration register
- AIR[1]: PSW register
- AIR[2]: TCP (timer comparator register)
- AIR[3]: Non-cacheable Offset register
- AIR[4]: Non-cacheable Mask register
- AIR[5]: Write-Through Offset register
- AIR[6]: Write-Through Mask register
- AIR[7]: PCO register (program counter)

Move to Itag
MTITAG

Format: MTITAG b

0:5	5:10	11:15	21:25	26	27:31
05	b	-	-	08	-
6	5	5	2	3	5

Purpose: To copy a value into Itag from a general register.
Description: GR r is copied into a specified entry of Itag.
Operation: entry <-- GR[b][24:31];
 Itag[entry][0:20] <-- GR[b][0:20];
Exception: Privilege instruction trap.
Restriction: This instruction can be executed only by code running at the most privileged level.
Note: Itag[entry][0:19]: tag field.
 Itag[entry][20]: valid bit.

Move from Itag

Format: MFITAG b,t

0:5	5:10	11:15	21:25	26	27:31
05	b	-	-	09	t
6	5	5	2	3	5

Purpose: To copy a value into general register from Itag.
Description: The content of a specified Itag_entry is copied into GR t.
Operation: way <-- AIR[0][26];
 entry <-- {way, GR[b][25:31]};
 GR[t][0:21] <-- Itag[entry][0:21]
Exception: Privilege instruction trap.
Restriction: This instruction can be executed only by code running at the most privileged level.

Move to I-Cache
MTICAH

Format: MTICAH r,b

0:5	5:10	11:15	21:25	26	27:31
05	b	r	-	-	0A
6	5	5	2	3	5 1 5

Purpose: To copy a value into I-Cache from a general register.

Description: GR r is copied into specified I-Cache entry.

 Operation:

```

entry <-- GR[b][21:27];
word <-- GR[b][28:29];
way <-- AIR[0][26];

```

Exception: I-Cache[way, entry, word] <-- GR[r];

Exception: Privilege instruction trap.

Restriction: This instruction can be executed only by code running at the most privileged level.

Move from I-Cache
MFICAH

Format: MFICAH b,t

0:5	5:10	11:15	21:25	26	27:31
05	b	-	-	-	0B - t
6	5	5	2	3	5 1 5

Purpose: To copy a value into general register from I-Cache.

Description: A word of specified I-Cache entry is copied into GR t.

 Operation:

```

  entry <-- GR[b][21:27];
  word <-- GR[b][28:29];
  way <-- AIR[0][26];
  GR[t] <-- I-Cache[way, entry, word];
  
```

Exception: Privilege instruction trap.

Restriction: This instruction can be executed only by code running at the most privileged level.

Move to Dtag
MTDTAG

Format:		MTDTAG			b		
0:5	5:10	11:15	21:25	26	27:31		
05	b	-	-	-	0C	-	-
6	5	5	2	3	5	1	5

Purpose: To copy a value into Dtag from a general register.
Description: GR r is copied into a specified entry of Dtag.
Operation: entry \leftarrow GR[b][25:31];
 ltag[entry][0:22] \leftarrow GR[b][0:22];
Exception: Privilege instruction trap.
Restriction: This instruction can be executed only by code running at the most privileged level.
Note: ltag[entry][0:21]: tag field.
 ltag[entry][22]: valid bit.
 ltag[entry][23]: dirty bit.

Move from Dtag
MFDTAG

Format:		MFDTAG			b,t		
0:5	5:10	11:15	21:25	26	27:31		
05	b	-	-	-	0D	-	t
6	5	5	2	3	5	1	5

Purpose: To copy a value into general register from Dtag.
Description: The content of a specified Dtag_entry is copied into GR t.
Operation: entry <-- GR[b][25:31];
 GR[t][0:22] <-- ltag[entry][0:22]
Exception: Privilege instruction trap.
Restriction: This instruction can be executed only by code running at the most privileged level.

Move to D-Cache
MTDTAG

Format: MTDCAH r,b

0:5	5:10	11:15				21:25	26	27:31
05	b	r	-	-	0E	-	-	-
6	5	5	2	3	5	1	5	

Purpose: To copy a value into D-Cache from a general register.
Description: GR r is copied into specified D-Cache entry.
Operation: entry <-- GR[b][21:27];
word <-- GR[b][28:29];
I-Cache[entry, word] <-- GR[r];
Exception: Privilege instruction trap.
Restriction: This instruction can be executed only by code running at the most privileged level.

Move from D-Cache
MFDCAH

Format: MFDCAH b,t
 0:5 5:10 11:15 21:25 26 27:31

05	b	-	-	-	0F	-	t
6	5	5	2	3	5	1	5

Purpose: To copy a value into general register from D-Cache.
 Description: A word of specified D-Cache entry is copied into GR t.
 Operation: entry <-- GR[b][21:27];
 word <-- GR[b][28:29];
 GR[t] <-- I-Cache[entry, word];
 Exception: Privilege instruction trap.
 Restriction: This instruction can be executed only by code running at the most privileged level.

Halfword Parallel Multiply

HPMPY

Format: HPMPY,cmplt r1,r2,t

0:5	6:10	11:15	21:25	26	27:31
05	r2	r1	sat	g	t
6	5	5	2	1	2

Purpose: To multiply multiple pairs of halfwords in parallel with optional saturation.

Description: The corresponding halfwords of GR *r1* and GR *r2* are multiplied together in parallel. Optional saturation is performed, which forces each halfword result to either the maximum or the minimum value, if the result would have been out of the range of the target format. The halfword results are placed in GR *t*.

The completer, *cmplt*, determines whether modular, signed-saturation, or unsigned-saturation multiplication is performed. When no completer is specified modular arithmetic is performed. The completer "*ss*" designates signed saturation. The completer "*us*" indicates unsigned saturation. For signed saturation, all operands are treated as signed numbers, and the results are signed numbers. For unsigned saturation, the first operands, from GR *r1*, are treated as unsigned numbers, the second operands, from GR *r2*, are treated as signed numbers, and the results are unsigned numbers.

Operation:

```
switch(cmplt) {
  case u(g=0, sat=00, unsigned multiplication) {
    GR[t]{0..15} ← zero_ext(GR[r1]{0..15}) × zero_ext(GR[r2]{0..15})
    GR[t]{16..31} ← zero_ext(GR[r1]{16..31}) × zero_ext(GR[r2]{16..31})
  }
  case s(g=1, sat=00, signed multiplication) {
    GR[t]{0..15} ← sign_ext(GR[r1]{0..15}) × sign_ext(GR[r2]{0..15})
    GR[t]{16..31} ← sign_ext(GR[r1]{16..31}) × sign_ext(GR[r2]{16..31})
  }
  case us(g=0, sat=01, unsigned multiplication with saturation) {
    GR[t]{0..15} ← zero_ext(GR[r1]{0..15}) × zero_ext(GR[r2]{0..15})
    GR[t]{16..31} ← zero_ext(GR[r1]{16..31}) × zero_ext(GR[r2]{16..31})
  }
  :
  if (unsigned_sat_L)      GR[t]{0..15} ← 0xFFFF;
  if (unsigned_sat_R)      GR[t]{16..31} ← 0xFFFF;
  break;
  }
  case ss(g=1, sat=01, signed multiplication with saturation) {
    GR[t]{0..15} ← sign_ext(GR[r1]{0..15}) × sign_ext(GR[r2]{0..15})
    GR[t]{16..31} ← sign_ext(GR[r1]{16..31}) × sign_ext(GR[r2]{16..31})
  }
  :
  if (pos_signed_sat_L)    GR[t]{0..15} ← 0x7FFF;
  else if (neg_signed_sat_L) GR[t]{0..15} ← 0x8000;
  if (pos_signed_sat_R)    GR[t]{16..31} ← 0x7FFF;
  else if (neg_signed_sat_R) GR[t]{16..31} ← 0x8000;
  break;
  }
  default:
    break;
}
}
```

Exception: None

Restriction: Winbond defined instruction for W90210F.

Halfword Multiply

HMPY

Format: HMPY, cmplt r1,r2,t

0:5	6:10	11:15	21:25	26	27:31
05	r2	r1	c g -	12	1 t
6	5	5	2 1 2	5	1 5

Purpose: To multiply corresponding halfwords of two registers.

Description: The corresponding 16-bit halfwords of GR *r1* and GR *r2* are interpreted as signed or unsigned 16-bit integers and are arithmetically multiplied together. The 32-bit result is placed in GR *t*.

The *cmplt* completer is specified by the *g* and the *c* bits in the instruction.

Operation:

```
switch(cmplt) {
  case uhh (g=0, c=00, unsigned multiplication) {
    GR[t]{0..31} ← zero_ext(GR[r1]{0..15}) × zero_ext(GR[r2]{0..15})
    break;
  }
  case shh (g=1, c=00, signed multiplication) {
    GR[t]{0..31} ← sign_ext(GR[r1]{0..15}) × sign_ext(GR[r2]{0..15})
    break;
  }
  case uhl (g=0, c=01, unsigned multiplication) {
    GR[t]{0..31} ← zero_ext(GR[r1]{0..15}) × zero_ext(GR[r2]{16:31})
    break;
  }
  case shl (g=1, c=01, signed multiplication) {
    GR[t]{0..31} ← sign_ext(GR[r1]{0..15}) × sign_ext(GR[r2]{16:31})
    break;
  }
  case ulh (g=0, c=10, unsigned multiplication) {
    GR[t]{0..31} ← zero_ext(GR[r1]{16:31}) × zero_ext(GR[r2]{0..15})
    break;
  }
  case slh (g=1, c=10, signed multiplication) {
    GR[t]{0..31} ← sign_ext(GR[r1]{16:31}) × sign_ext(GR[r2]{0..15})
    break;
  }
  case ull (g=0, c=11, unsigned multiplication) {
    GR[t]{0..31} ← zero_ext(GR[r1]{16:31}) × zero_ext(GR[r2]{16:31})
    break;
  }
  case sll (g=1, c=11, signed multiplication) {
    GR[t]{0..31} ← sign_ext(GR[r1]{16:31}) × sign_ext(GR[r2]{16:31})
    break;
  }
}
```

Exception: None

Restriction: Winbond defined instruction for W90210F.

Halfword Absolute and Add
HABSADD
Format: HABSADD, cmplt r1, r2, t

0:5	6:10	11:15	16:17	18:20	21:25	26	27:31
05	r2	r1	sat	-	13	-	t
6	5	5	2	3	5	1	5

Purpose: To add multiple pairs of halfwords in parallel with absolute and optional saturation.

Description: The corresponding halfwords of GR r1 are added with the halfwords of absolute GR r2 in parallel. Optional saturation is performed, which forces each halfword result to either the maximum or the minimum value, if the result would have been out of the range of the target format. The halfword results are placed in GR t.

The completer, cmplt, determines whether modular, signed-saturation, or unsigned-saturation arithmetic is performed. When no completer is specified (sat=3) modular arithmetic is performed. The completer "ss" (sat=1) designates signed saturation. The completer "us" (sat=0) indicates unsigned saturation. For signed saturation, all operands are treated as signed numbers, and the results are signed numbers. For unsigned saturation, the first operands, from GR r1, are treated as unsigned numbers, the second operands, from GR r2, are treated as signed numbers, and the results are unsigned numbers.

Operation:

```

if (GR[r2]{0} == 1) GR[t]{0..15} ← GR[r1]{0..15} + (~GR[r2]{0..15} + 1);
else GR[t]{0..15} ← GR[r1]{0..15} + GR[r2]{0..15};
if (GR[r2]{16} == 1) GR[t]{16..31} ← GR[r1]{16:31} + (~GR[r2]{16..31} + 1);
else GR[t]{16..31} ← GR[r1]{16:31} + GR[r2]{16..31};
switch (cmplt) {
    case ss: if(max_signed_sat_L) /* sat=1*/
              GR[t]{0:15} ← 0x7FFF;
              else if (min_signed_sat_L)
              GR[t]{0:15} ← 0x8000;
              if(max_signed_sat_R)
              GR[t]{16:31} ← 0x7FFF;
              else if (min_signed_sat_R)
              GR[t]{16:31} ← 0x8000;
              break;
    case us: if(max_unsigned_sat_L) /*sat=0*/
              GR[t]{0:15} ← 0xFFFF;
              else if (min_unsigned_sat_L)
              GR[t]{0:15} ← 0x0000;
              if(max_unsigned_sat_R)
              GR[t]{16:31} ← 0xFFFF;
              else if (min_unsigned_sat_R)
              GR[t]{16:31} ← 0x0000;
              break;
    default: /*sat=3*/
              break;
}

```

Exceptions: None

Restriction: Winbond defined instruction for W90210F.

Load Halfword Unpacked
LDHU
Format: LDHU, cmplt d(s,b),t

0:5	5:10	11:15	21:25	26	27:31
05	b	im5	s	a	- 14 m t
6	5	5	2	1	3 5 1 5

Purpose: To load a halfword and unpack into a general register.

Description: The aligned halfword at the effective address is uppacked into two bytes, zero-extended to two halfwords and loaded into GR t. The completer, cmplt, determines if the offset is the base register, b, or the base register plus the short displacement, d. The displacement is encoded in the im5 field. The completer, encoded in the a and m fields of the instruction, also specifies base register modification. If base register modification is specified and b=t, the value loaded is the unpacked halfwords at the effective address.

Operation:

```

switch (cmplt) {
  case MB:  offset ← GR[b] + low_sign_ext(im5,5);    /* a=1,m=1 */
            GR[b] ← GR[b] + low_sign_ext(im5,5);
            break;
  case MA:  offset ← GR[b];                          /* a=0,m=1 */
            GR[b] ← GR[b] + low_sign_ext(im5,5);
            break;
  default:  offset ← GR[b] + low_sign_ext(im5,5);    /* m=0 */
            break;
}
GR[t] ← cat(zero_ext(mem_load(offset,0,7),16), zero_ext(mem_load(offset,8,15),16))

```

Exception: None.

Restriction: Winbond defined instruction for W90210F.



CORPORATE HEADQUARTERS:
NO. 4, Creation Rd. III
Science-Based Industrial Park
Hsinchu, Taiwan, R.O.C.
TEL: 886-35-770066
FAX: 886-35-792647

INFORMATION CONTACTS:
Rongken Yang
Special Product Design Dept. I
TEL: 886-35-792632
E-mail: rkyang@winbond.com.tw

Note: All data and specifications are subject to change without notice.