



WT8072

PIR CONTROLLER

GENERAL DESCRIPTION

WT 8072 is a PIR (passive infra-red) controller, using analog mixing digital design technique and manufactures by CMOS process which can either drive TRIAC or RELAY depending on users' choice. With special noise immunity technique, WT8072 is the most stable PIR controller you can find on the market. More than this, there are few components needed in its application circuit which can reduce material cost and increase competitive.

FEATURES

- *HIGH NOISE IMMUNITY.
- *DRIVE EITHER RELAY OR TRIAC.
- *ADJUSTABLE LIGHT ON DURATION.
- *TRIAC CAN BE EITHER SHUNT OR SERIAL CONNECTED.
- *PIR INPUT.
- *CDS INPUT.

PIN CONFIGURATION

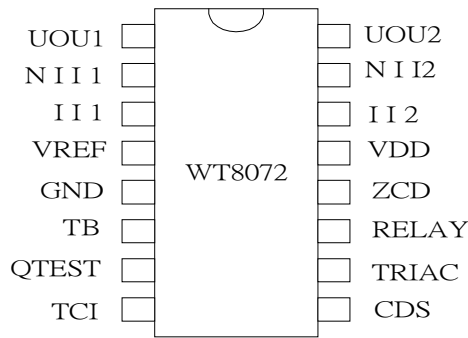

PIN DESCRIPTION

Pin No.	Pin Name	I/O	Description
1	UOU1		First stage OP amp output
2	NII 1		First stage OP amp positive input
3	II 1		First stage OP amp negative input
4	VREF		Stable reference voltage
5	GND		System ground
6	TB		Time base for 1. The delay time of receiving PIR signal to sent a puls to trigger TRIAC or a high signal to trigger relay. The delay time = $R \times C \times 32$. The PIR signal patented and accepted only if the signal cycle greater than $R \times C \times 768$.When state of relay or TRIAC is changing form active into inactive mode. It takes more than $R \times C \times 4069$, then system is able to receive PIR signal again. 2.The flash cycle show the beginning of auto mode. Note: Width of TRIAC pulse = $R \times C \times 2$. Flash cycle: $R \times C \times 32768$ $10\text{ K} < R < 1\text{M Ohm}$ $100\text{pF} < C < 0.1\text{ Uf}$ (Reference Diagram 1)
7	QTEST		For testing only

8	TCI		To set up the timing of how long Triac or relay is active. During the period, if the system receives the PIR signal, then it restarts counting the timing again. The range for R: $10K < R < 1M \text{ Ohm}$ C: $100\mu F < C < 0.1 \mu F$ (Reference Diagram 2)
9	CDS		Connected to a CDS for inhibiting relay or TRIAC being triggered. If TRIAC or relay has already being triggered by PIR signal and turned into active mode, then CDS can not inhibit PIR again.
10	TRIAC		To trigger TRIAC, active low Sink current: 15 mA max.
11	RELAY		To drive relay, active high Sink current: 10 mA max. Source current: 10 mA max.
12	ZCD		Detect zero cross of AC line under remote mode function.
13	VDD		Operation voltage: 5V, stand by current: 1mA
14	I12		2 nd stage OP amp negative input
15	NI12		2 nd stage OP amp positive input
16	UOU2		2 nd stage OP amp output

DIAGRAM 1, 2

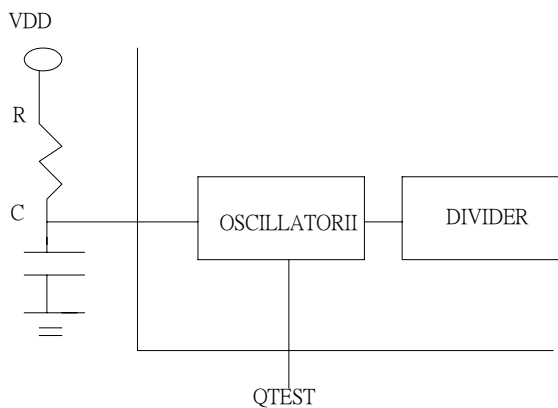
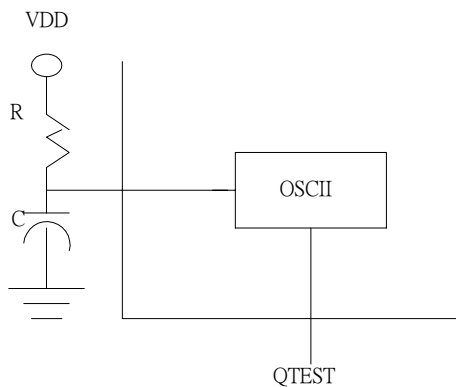



Absolute Maximum Ratings

Parameter	SYMBOL	VALUE	Units
POWER SUPPLY Vdd WITH REPECT TO Vss	Vdd-Vss	5.6	V
VOLTAGE ON ANY PIN		-0.3-5.6	V
OPERATING TEMPERATURE	Top	0-70	C
STORAGE TEMPERATURE		-65-150	C

ELECTRICAL CHARACTERISTICS

Symbol	Parameter	Condition	Min.	Typ.	Max.	Unit
Vdd	SUPPLY VOLTAGE		4.2	5	5.5	V
Ist	STANDY CURRENT		0.9	1.0	1.2	mA
Idd	OPERATING CURRENT	1.8mA, TRIAC 2.5mA, RELAY	1.8		2.5	mA
Vref	STABLE VOLTAGE	Vdd>4.2V	3.0	3.2	3.4	V
Iref	SOURCE CURRENT OF Vref		200			uA
	RIPPLE OF Vref				0.5	mV
	INPUT AND OUTPUT REGULATION OF Vref				0.3%	
Ftb	TIME BASE OPERATING FREQUENCY		15	16	17	KHZ
Vt+	CDS OPERATING TRIGGER		1.3	1.7	2.1	V
Vt-	CDS OPREATING TRIGGER		0.6	0.9	1.1	V
Icds	CDS SOURCE CURRENT		2.6	3.5	4.4	uA
Isource	CDS OUTPUT SOURCE CURRENT		9	10.4	17.4	mA
Isink	CDS OUTPUT SINK CURRENT		11.6	13	21	mA
Tout1	TIMER DURATION OF OUT 1	C=0.001uF R=4.7K-1M C=0.01uF R=4.7K-1M C=100uF R=4.7K-1M C=0.1uF R=4.7K-1M	0.03 4.6 0.08 37.8		9.3 1290 14.9 11170	Sec.
Irs	RELAY SOURCE CURRENT				5	mA
Irsink	RELAY SINK CURRENT				5	mA
Vro	RELAY OPERATING VOLTAGE	18.8V: RELAY ON 13.1V: RELAY OFF	13.1		18.8	V
Itsink	TRIAC SINK CURRENT				15	mA
Itsource	TRIAC SOURCE CURRENT				50	uA



WT8072

PIR CONTROLLER

TYPICAL APPLICATION

HOME SECURITY SYSTEM.

AUTO LIGHT SYSTEM FOR GARDEN, GARAGE, HALLWAY, STAIRCASE, PORCH, BATHROOM, AND ETC.

AUTO SWITCH FOR VENTILATION FAN.

AUTO NOTICE SYSTEM FOR OFFICE, STORAGE, AND ETC.

ORDERING INFORMATION

Ordering Number	Package Type
WT8072	P-DIP 16L
WT8072H	CHIP FORM



WT8072

PIR CONTROLLER

Copyright © Each Manufacturing Company.

All Datasheets cannot be modified without permission.

This datasheet has been download from :

www.AllDataSheet.com

100% Free DataSheet Search Site.

Free Download.

No Register.

Fast Search System.

www.AllDataSheet.com