

### Dual Two-wiper Digitally-Controlled (XDCP™) Potentiometer

The X9455 integrates 2 digitally controlled potentiometers (XDCP), each one with dual wipers, on a monolithic CMOS integrated circuit.

The digitally controlled potentiometer is implemented using 255 resistive elements in a series array. Between each element are tap points connected to wiper terminals through switches. The position of each wiper on the array is controlled by the user through the U/D or 2-wire bus interface. Each potentiometer wiper has associated with it two volatile Wiper Counter Register (WCR) and each WCR has associated with it four non-volatile Data Registers that can be directly written to and read by the user. The contents of the WCR controls the position of the wiper on the resistor array through the switches. The contents of the default data registers (DR0A0, DR0B0, DR1A0, DR1B0) are loaded into the WCR on power up.

The DCP can be used as a four-terminal potentiometer in a wide variety of applications including the programming of bias voltages, window comparators, and three resistor programmable networks.

### Ordering Information

PART NUMBER	RTOTAL	PACKAGE	OPERATING TEMP RANGE (°C)
X9455YV24-2.7	2.8kΩ	24-lead TSSOP	0 to 70
X9455YV24I-2.7	2.8kΩ	24-lead TSSOP	-40 to +85
X9455WV24-2.7	10kΩ	24-lead TSSOP	0 to 70
X9455WV24I-2.7	10kΩ	24-lead TSSOP	-40 to +85
X9455UV24-2.7	50kΩ	24-lead TSSOP	0 to 70
X9455UV24I-2.7	50kΩ	24-lead TSSOP	-40 to +85
X9455TV24-2.7	100kΩ	24-lead TSSOP	0 to 70
X9455TV24I-2.7	100kΩ	24-lead TSSOP	-40 to +85

### Features

- Dual Two-wiper solid state potentiometer
- 256 Resistor tap points-0.4% resolution
- 2-wire serial interface for Write, Read, and transfer operations of the potentiometer
- Up/Down interface for individual potentiometer wipers
- Wiper resistance, 40Ω typical
- Non-volatile storage of wiper positions
- Power On Recall Loads saved wiper position on Power Up.
- Standby Current < 20µA Max
- Maximum Wiper Current: 3mA
- V<sub>CC</sub>: 2.7V to 5.5V operation
- 2.8kΩ, 10kΩ, 50kΩ, 100kΩ version of total pot resistance
- Endurance: 100,000 Data changes per bit per register
- 100 yr. data retention
- 24-Lead TSSOP

### Pinout

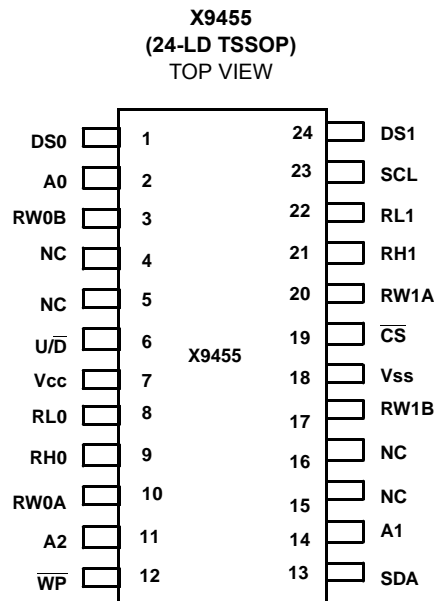

**Functional Diagram**

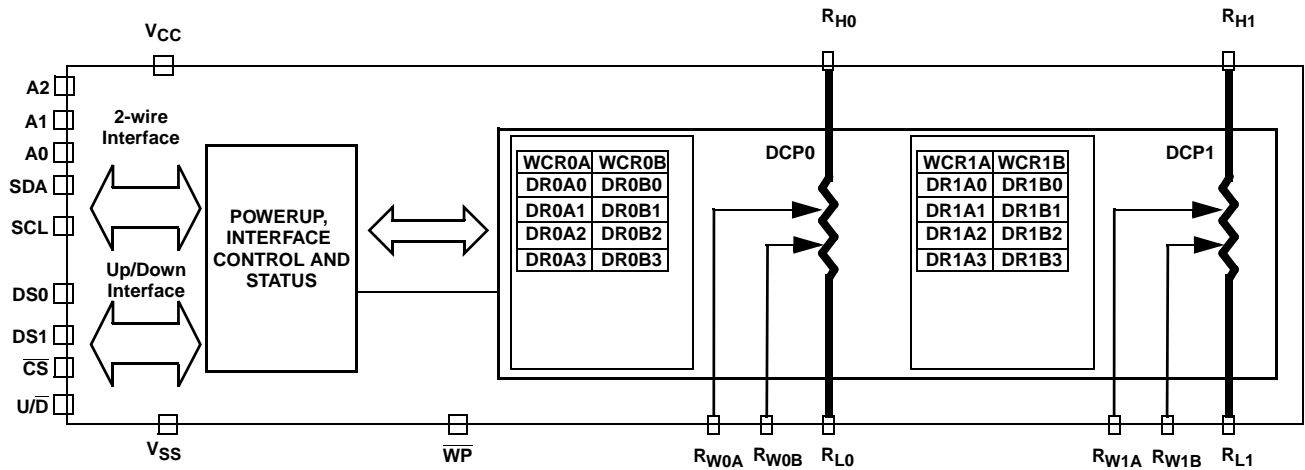

**Pin Descriptions**

TSSOP PIN	SYMBOL	BRIEF DESCRIPTION
1	DS0	Wiper Selection input for Up/Down interface
2	A0	Device Address for 2-wire interface
3	RW0B	Second Wiper Terminal of DCP0
4	NC	No Connect
5	NC	No Connect
6	$\overline{U/D}$	Increment/Decrement for Up/Down interface
7	VCC	System Supply Voltage
8	RL0	Low Terminal of DCP0
9	RH0	High Terminal of DCP0
10	RW0A	First Wiper Terminal of the DCP0
11	A2	Device Address for 2-wire interface
12	$\overline{WP}$	Hardware Write Protect (Active low)
13	SDA	Serial Data Input/Output for 2-wire interface
14	A1	Device Address for 2-wire interface
15	NC	No Connect
16	NC	No Connect
17	RW1B	Second Wiper Terminal of DCP1
18	VSS	System Ground
19	$\overline{CS}$	Chip select for Up/Down interface
20	RW1A	First Wiper Terminal of DCP1
21	RH1	High Terminal of DCP1
22	RL1	Low Terminal of DCP1
23	SCL	Serial Clock for 2-wire interface
24	DS1	Wiper selection input for Up/Down interface

**Absolute Maximum Ratings**

Junction Temperature under bias ..... -65°C to +135°C  
 Storage temperature ..... -65°C to +150°C  
 Voltage at any digital interface pin  
 with respect to V<sub>SS</sub> ..... -1V to +7V  
 V<sub>CC</sub> ..... -1V to +7V  
 Voltage at any DCP pin with  
 respect to V<sub>SS</sub> ..... -1V to V<sub>CC</sub>  
 Lead temperature (soldering, 10 seconds) ..... 300°C  
 I<sub>W</sub> (10 seconds) ..... ±6mA

**Recommended Operating Conditions**

Commercial ..... 0°C to +70°C  
 Industrial ..... -40°C to +85°C  
 Supply Voltage (V<sub>CC</sub>) (Note 4) Limits ..... 2.7V to 5.5V

*CAUTION: Stresses above those listed under "Absolute Maximum Ratings" may cause permanent damage to the device. This is a stress rating only; functional operation of the device (at these or any other conditions above those listed in the operational sections of this specification) is not implied. Exposure to absolute maximum rating conditions for extended periods may affect device reliability.*

**Analog Specifications** Over recommended operating conditions unless otherwise stated.

SYMBOL	PARAMETER	TEST CONDITIONS	MIN	TYP (Note 4)	MAX	UNIT
R <sub>TOTAL</sub>	End to end resistance	Y, W, U, T versions respectively		2.8, 10, 50, 100		kΩ
	End to end resistance tolerance		-20		+20	%
	Power rating	25°C, each DCP			50	mW
R <sub>TOTAL</sub> Matching	DCP to DCP resistance matching			0.75	2.0	%
I <sub>W</sub> (Note 5)	Wiper current	See test circuit	-3.0		+3.0	mA
R <sub>W</sub>	Wiper resistance	Wiper current = $\frac{V_{CC}}{R_{TOTAL}}$		50	150	Ω
V <sub>TERM</sub>	Voltage on any DCP pin		V <sub>SS</sub>		V <sub>CC</sub>	V
	Noise (Note 5)	Ref: 1kHz		-120		dBV
	Resolution			0.4		%
	Absolute linearity (Note 1)	V(R <sub>H0</sub> )=V(R <sub>H1</sub> )=V <sub>CC</sub> V(R <sub>L0</sub> )=V(R <sub>L1</sub> )=V <sub>SS</sub>	-1		+1	MI (Note 3)
	Relative linearity (Note 2)		-0.3		+0.3	MI (Note 3)
	Temperature coefficient of resistance (Note 5)			±300		ppm/°C
	Ratiometric Temperature (Note 5) Coefficient		-20		+20	ppm/°C
C <sub>H</sub> /C <sub>L</sub> /C <sub>W</sub>	Potentiometer Capacitance (Note 5)	See equivalent circuit		10/10/25		pF
I <sub>OL</sub>	Leakage on DCP pins	Voltage at pin from V <sub>SS</sub> to V <sub>CC</sub>		0.1	10	μA

**DC Electrical Specifications** Over the recommended operating conditions unless otherwise specified.

SYMBOL	PARAMETER	TEST CONDITIONS	MIN	MAX	UNITS
I <sub>CC1</sub>	V <sub>CC</sub> supply current (Volatile write/read)	f <sub>SCL</sub> = 400kHz; SDA = Open; (for 2-Wire, Active, Read and Volatile Write States only)		3	mA
I <sub>CC2</sub>	V <sub>CC</sub> supply current (active)	f <sub>SCL</sub> = 200kHz; (for U $\bar{D}$ interface, increment, decrement)		3	mA
I <sub>CC3</sub>	V <sub>CC</sub> supply current (nonvolatile write)	f <sub>SCL</sub> = 400kHz; SDA = Open; (for 2-Wire, Active, Nonvolatile Write State only)		5	mA
I <sub>SB</sub>	V <sub>CC</sub> current (standby)	V <sub>CC</sub> = +5.5V; V <sub>IN</sub> = V <sub>SS</sub> or V <sub>CC</sub> ; SDA = V <sub>CC</sub> ; (for 2-Wire, Standby State only)		20	μA
I <sub>L</sub>	Leakage current, bus interface pins	Voltage at pin from V <sub>SS</sub> to V <sub>CC</sub>	-10	10	μA

**DC Electrical Specifications** Over the recommended operating conditions unless otherwise specified. (Continued)

SYMBOL	PARAMETER	TEST CONDITIONS	MIN	MAX	UNITS
V <sub>IH</sub>	Input HIGH voltage		V <sub>CC</sub> × 0.7	V <sub>CC</sub> + 1	V
V <sub>IL</sub>	Input LOW voltage		-1	V <sub>CC</sub> × 0.3	V
V <sub>OL</sub>	SDA pin output LOW voltage	I <sub>OL</sub> = 3mA		0.4	V

**Endurance and Data Retention**

PARAMETER	MIN	UNITS
Minimum endurance	100,000	Data changes per bit
Data retention	100	Years

**Capacitance**

SYMBOL	TEST	TEST CONDITIONS	MAX	UNITS
C <sub>IN/OUT</sub> (Note 5)	Input / Output capacitance (SDA)	V <sub>OUT</sub> = 0V	8	pF
C <sub>IN</sub> (Note 5)	Input capacitance (DS0, DS1, $\overline{CS}$ , U/ $\overline{D}$ , SCL, $\overline{WP}$ , A2, A1 and A0)	V <sub>IN</sub> = 0V	6	pF

**Power-Up Timing**

SYMBOL	PARAMETER	MAX	UNITS
t <sub>D</sub> (Notes 5, 9)	Power Up Delay from V <sub>CC</sub> power up (V <sub>CC</sub> above 2.7V) to wiper position recall completed, and communication interfaces ready for operation.	2	ms

**A.C. Test Conditions**

Input Pulse Levels	V <sub>CC</sub> × 0.1 to V <sub>CC</sub> × 0.9
Input rise and fall times	10ns
Input and output timing threshold level	V <sub>CC</sub> × 0.5
External load at pin SDA	2.3kΩ to V <sub>CC</sub> and 100 pF to V <sub>SS</sub>

**2-Wire Interface Timing (s)**

SYMBOL	PARAMETER	MIN	MAX	UNITS
f <sub>SCL</sub>	Clock Frequency		400	kHz
t <sub>HIGH</sub>	Clock High Time	600		ns
t <sub>LOW</sub>	Clock Low Time	1300		ns
t <sub>SU:STA</sub>	Start Condition Setup Time	600		ns
t <sub>HD:STA</sub>	Start Condition Hold Time	600		ns
t <sub>SU:STO</sub>	Stop Condition Setup Time	600		ns
t <sub>SU:DAT</sub>	SDA Data Input Setup Time	100		ns
t <sub>HD:DAT</sub>	SDA Data Input Hold Time	30		ns
t <sub>R</sub> (Note 5)	SCL and SDA Rise Time		300	ns
t <sub>F</sub> (Note 5)	SCL and SDA Fall Time		300	ns
t <sub>AA</sub> (Note 5)	SCL Low to SDA Data Output Valid Time		0.9	μs
t <sub>DH</sub>	SDA Data Output Hold Time	0		ns
t <sub>IN</sub> (Note 5)	Pulse Width Suppression Time at SCL and SDA inputs		50	ns
t <sub>BUF</sub> (Note 5)	Bus Free Time (Prior to Any Transmission)	1200		ns

2-Wire Interface Timing (s) (Continued)

SYMBOL	PARAMETER	MIN	MAX	UNITS
$t_{SU:WPA}$ (Note 5)	A0, A1, A2 and $\overline{WP}$ Setup Time	600		ns
$t_{HD:WPA}$ (Note 5)	A0, A1, A2 and $\overline{WP}$ Hold Time	600		ns

SDA vs. SCL Timing

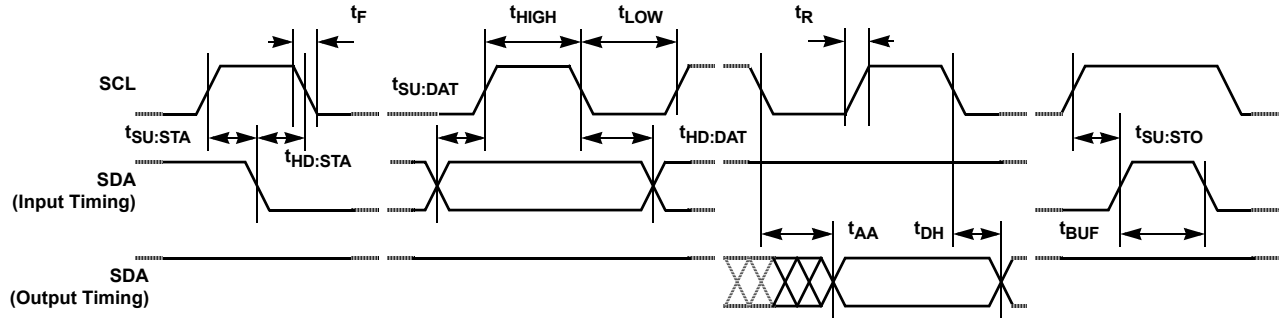

$\overline{WP}$ , A0, A1, and A2 Pin Timing

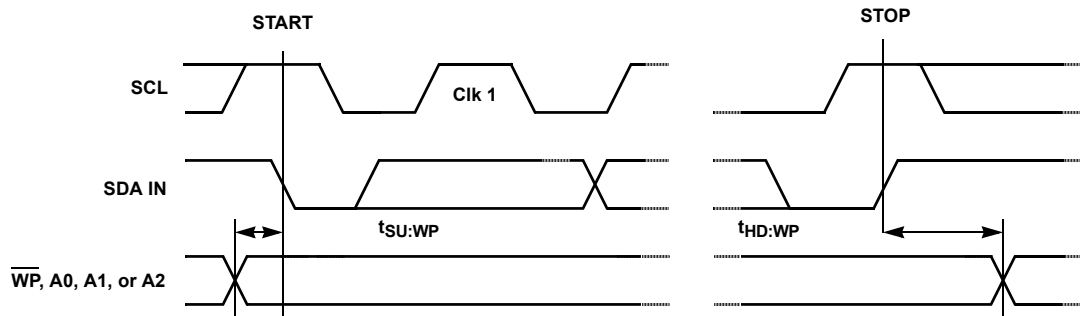

Increment/Decrement Timing

SYMBOL	PARAMETER	MIN	TYP (Note 4)	MAX	UNITS
$t_{CI}$	$\overline{CS}$ to SCL Setup	600			ns
$t_{ID}$ (Note 5)	SCL HIGH to $\overline{U/D}$ , DS0 or DS1 change	600			ns
$t_{DI}$ (Note 5)	$\overline{U/D}$ , DS0 or DS1 to SCL setup	600			ns
$t_{IL}$	SCL LOW period	2.5			$\mu$ s
$t_{IH}$	SCL HIGH period	2.5			$\mu$ s
$t_{IC}$	SCL inactive to $\overline{CS}$ inactive (Nonvolatile Store Setup Time)	1			$\mu$ s
$t_{CPHS}$	$\overline{CS}$ deselect time (STORE)	10			ms
$t_{CPHNS}$ (Note 5)	$\overline{CS}$ deselect time (NO STORE)	1			$\mu$ s
$t_{IW}$ (Note 5)	SCL to $R_W$ change		100	500	$\mu$ s
$t_{CYC}$	SCL cycle time	5			$\mu$ s
$t_R, t_F$ (Note 5)	SCL input rise and fall time			500	$\mu$ s

**Increment/Decrement Timing**

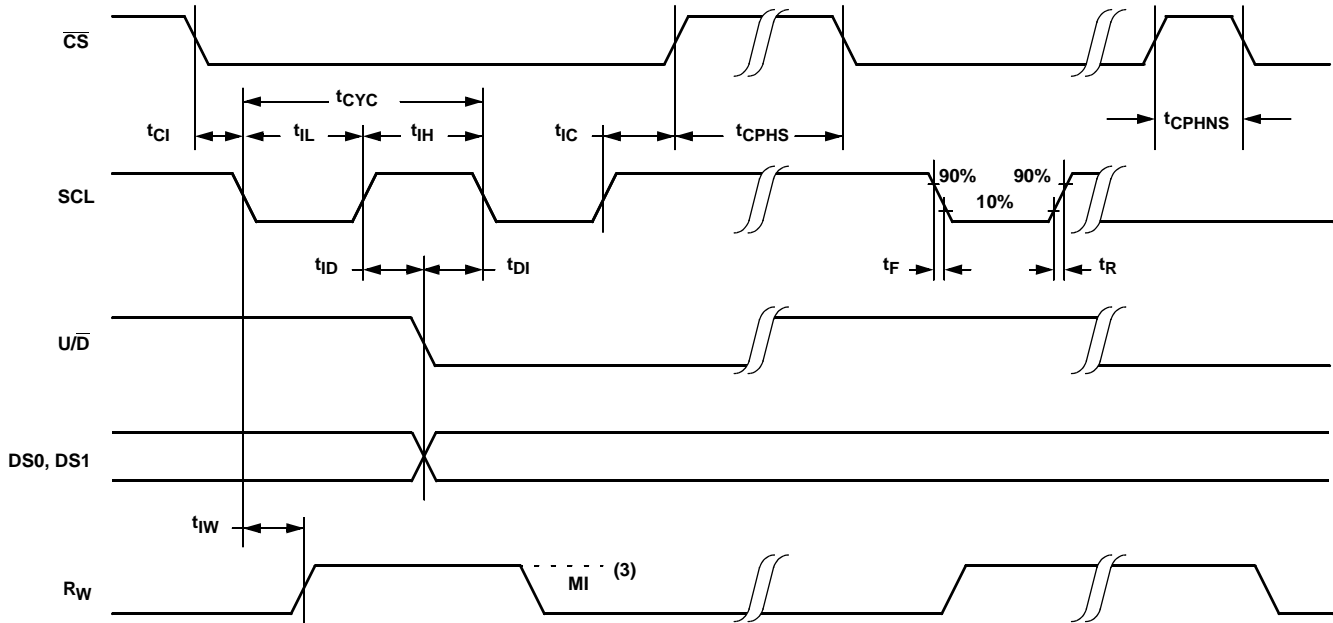

**High-Voltage Write Cycle Timing**

SYMBOL	PARAMETER	TYP	MAX	UNITS
$t_{WC}$ (Notes 5, 8)	Non-volatile write cycle time	5	10	ms

**XDCCP Timing**

SYMBOL	PARAMETER	MIN	MAX	UNITS
$t_{WRL}$ (Note 5)	SCL rising edge to wiper code changed, wiper response time after instruction issued (all load instructions)	5	20	$\mu s$

NOTES:

- Absolute linearity is utilized to determine actual wiper voltage versus expected voltage =  $[V(R_{W(n)(actual)}) - V(R_{W(n)(expected)})] / MI$   
 $V(R_{W(n)(expected)}) = n(V(R_H) - V(R_L)) / 255 + V(R_L)$ , with n from 0 to 255.
- Relative linearity is a measure of the error in step size between taps =  $[V(R_{W(n+1)}) - (V(R_{W(n)}) + MI)] / MI$ , with n from 0 to 254
- 1 MI = Minimum Increment =  $[V(R_H) - V(R_L)] / 255$ .
- Typical values are for  $T_A = 25^\circ C$  and nominal supply voltage.
- This parameter is not 100% tested.
- Ratiometric temperature coefficient =  $(V(R_W)_{T1(n)} - V(R_W)_{T2(n)}) / [V(R_W)_{T1(n)}(T1 - T2)] \times 10^6$ , with T1 & T2 being 2 temperatures, and n from 0 to 255.
- Measured with wiper at tap position 255,  $R_L$  grounded, using test circuit.
- $t_{WC}$  is the minimum cycle time to be allowed for any nonvolatile write by the user, unless Acknowledge Polling is used. It is the time from a valid STOP condition at the end of a write sequence of a 2-wire interface write operation, or from the rising edge of  $\overline{CS}$  of a valid "Store" operation of the Up/Down interface, to the end of the self-timed internal nonvolatile write cycle.
- The recommended power up sequence is to apply  $V_{CC}/V_{SS}$  first, then the potentiometer voltages. During power up, the data sheet parameters for the DCP do not fully apply until  $t_D$  after  $V_{CC}$  reaches its final value. In order to prevent unwanted tap position changes, or an inadvertent store, bring the  $\overline{CS}$  pin high before or concurrently with the  $V_{CC}$  pin on power up.

**Test Circuit**

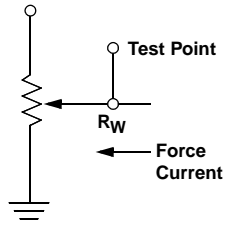

**Equivalent Circuit**

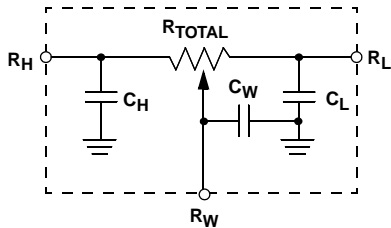

**Pin Descriptions**

**Bus Interface Pins**

**Serial Data Input/Output (SDA)**

The SDA is a bidirectional serial data input/output pin for the 2-wire interface. It receives device address, operation code, wiper register address and data from a 2-wire external master device at the rising edge of the serial clock SCL, and it shifts out data after each falling edge of the serial clock SCL.

SDA requires an external pull-up resistor, since it's an open drain output.

**Serial Clock (SCL)**

This input is the serial clock of the 2-wire and Up/Down interface.

**Device Address (A2-A0)**

The Address inputs are used to set the least significant 3 bits of the 8-bit 2-wire interface slave address. A match in the slave address serial data stream must be made with the Address input pins in order to initiate communication with the X9455. A maximum of 8 devices may occupy the 2-wire serial bus.

**Chip Select ( $\overline{CS}$ )**

When the  $\overline{CS}$  pin is low, increment or decrement operations are possible using the SCL and  $\overline{U/D}$  pins. The 2-wire interface is disabled at this time. When  $\overline{CS}$  is high, the 2-wire interface is enabled.

**Up or Down Control ( $\overline{U/D}$ )**

The  $\overline{U/D}$  input pin is held HIGH during increment operations and held LOW during decrement operations.

**DCP Select (DS1-DS0)**

The DS1-DS0 select one of the four DCPs for an Up/Down interface operation.

**Hardware Write Protect Input ( $\overline{WP}$ )**

When the  $\overline{WP}$  pin is set low, "write" operations to non volatile DCP Data Registers are disabled. This includes both 2-wire interface non-volatile "Write", and Up/Down interface "Store" operations.

**DCP Pins**

**$R_{H0}$ ,  $R_{L0}$ ,  $R_{H1}$ ,  $R_{L1}$**

These pins are equivalent to the terminal connections on mechanical potentiometers. Since there are two DCPs, there is one set of  $R_H$  and  $R_L$  for each DCP.

**$R_{W0A}$ ,  $R_{W0B}$ ,  $R_{W1A}$ , and  $R_{W1B}$**

The wiper pins are equivalent to the wiper terminals of mechanical potentiometers. Since there are two wipers per DCP, there are four  $R_W$  pins.

## Principles of Operation

The X9455 is an integrated circuit incorporating two resistor arrays with dual wipers on each array, their associated registers and counters, and the serial interface logic providing direct communication between the host and the digitally controlled potentiometers. This section provides detail description of the following:

- Resistor Array
- Up/Down Interface
- 2-wire Interface

## Resistor Array Description

The X9455 is comprised of two resistor arrays. Each array contains 255 discrete resistive segments that are connected in series. The physical ends of each array are equivalent to the fixed terminals of a mechanical potentiometer ( $R_{Hi}$  and  $R_{Li}$  inputs). (See Figure 1.)

Each array has two independent wipers. At both ends of each array and between each resistor segment are two

switches, one connected to each of the wiper pins ( $R_{WiA}$  and  $R_{WiB}$ ).

Within each individual array only one switch of each wiper may be turned on at a time.

These switches are controlled by two Wiper Counter Register (WCR). The 8-bits of the WCR are decoded to select and enable one of 256 switches. Note that each wiper has a dedicated WCR. When all bits of a WCR are zeroes, the switch closest to the corresponding  $R_L$  pin is selected. When all bits of a WCR are ones, the switch closest to the corresponding  $R_H$  pin is selected.

The WCRs are volatile and may be written directly. There are four non-volatile Data Registers (DR) associated with each WCR. Each DR can be loaded into WCR. All DRs and WCRs can be read or written.

## Power Up and Down Requirements

During power up  $\overline{CS}$  must be high to avoid inadvertent "store" operations. At power up, the contents of Data Registers Level 0 ( $DR0A0$ ,  $DR0B0$ ,  $DR1A0$ , and  $DR1B0$ ), are loaded into the corresponding wiper counter register.

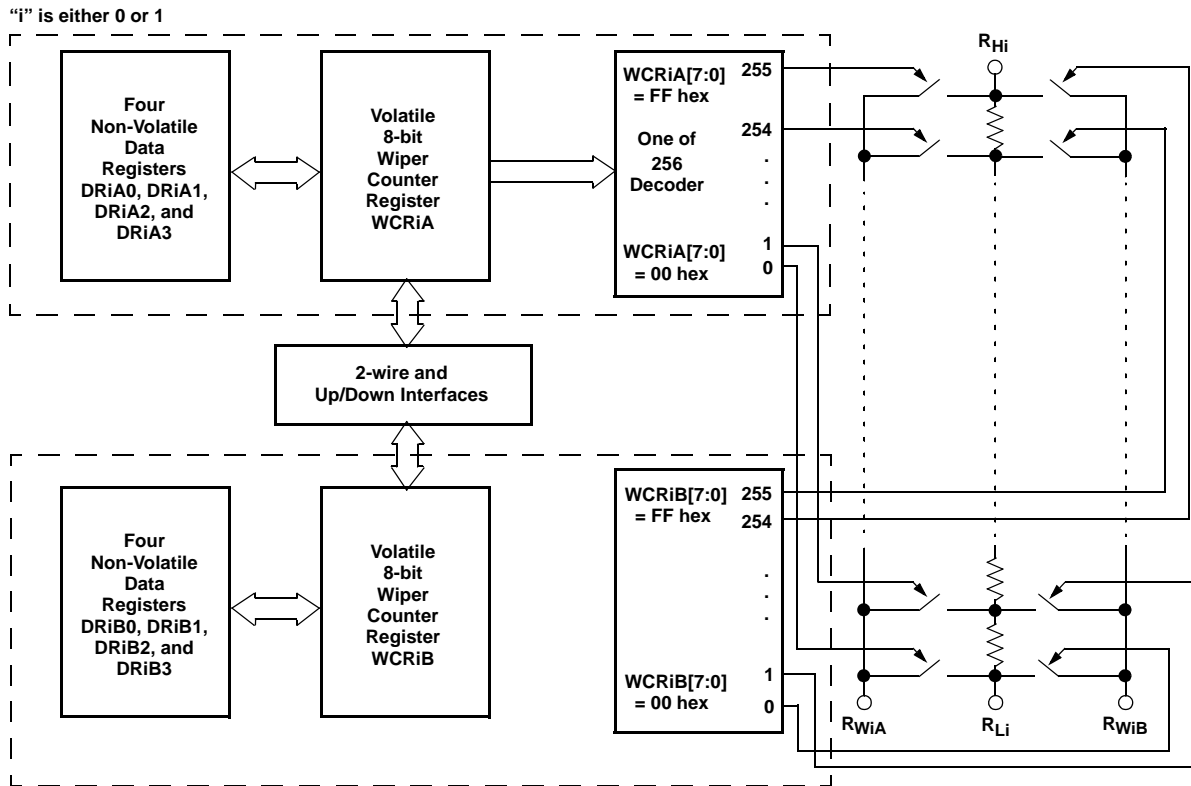

FIGURE 1. DETAILED BLOCK DIAGRAM OF ONE DCP



**Up/Down Interface Operation**

The SCL, U/D, CS, DS0 and DS1 inputs control the movement of the wiper along the resistor array. With CS set LOW the device is selected and enabled to respond to the U/D and SCL inputs. HIGH to LOW transitions on SCL will increment or decrement (depending on the state of the U/D input) a wiper counter register selected by DS0 and DS1. The output of this counter is decoded to select one of 256 wiper positions along the resistor array.

The value of the counter is stored in nonvolatile data register Level 0 of the corresponding WCR whenever CS transitions HIGH while the SCL and WP inputs are HIGH (See Table 1). During a "Store" operation bits WCRSel1 and WCRSel0 in the status register must be both "0", which is their power up default value. Other combinations are reserved and must not be used.

The system may select the X9455, move a wiper, and deselect the device without having to store the latest wiper position in nonvolatile memory. After the wiper movement is performed as described above and once the new position is reached, the system must keep SCL LOW while taking CS HIGH. The new wiper position is maintained until changed by the system or until a power-down/up cycle recalled the previously stored data.

This procedure allows the system to always power-up to a preset value stored in nonvolatile memory; then during system operation minor adjustments could be made. The adjustments might be based on user preference, system parameter changes due to temperature drift, etc.

The state of U/D may be changed while CS remains LOW. This allows the host system to enable the device and then move the wiper up and down until the proper trim is attained. The 2-wire interface is disabled while CS remains LOW.

**TABLE 1. DCP SELECTION FOR UP/DOWN CONTROL**

DS1	DS0	SELECTED WIPER CONTROL REGISTER
0	0	Wiper A of DCP0
1	1	Wiper B of DCP0
1	0	Wiper A of DCP1
0	1	Wiper B of DCP1

**TABLE 2. MODE SELECTION FOR UP/DOWN CONTROL**

CS	SCL	U/D	MODE
L		H	Wiper Up
L		L	Wiper Down
	H	X	Store Wiper Position to nonvolatile memory if WP pin is high. No store, return to standby, if WP pin is low.
H	X	X	Standby*
	L	X	No Store, Return to Standby
	L	H	Wiper Up (not recommended)
	L	L	Wiper Down (not recommended)

\*While in Standby, the 2-wire interface is enabled

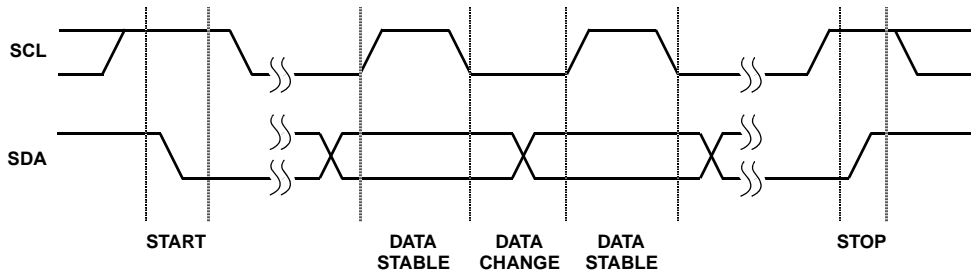

FIGURE 2. VALID DATA CHANGES, START, AND STOP CONDITIONS

## 2-Wire serial interface

### Protocol Overview

The device supports a bidirectional bus oriented protocol. The protocol defines any device that sends data onto the bus as a transmitter, and the receiving device as the receiver. The device controlling the transfer is called the master and the device being controlled is called the slave. The master always initiates data transfers, and provides the clock for both transmit and receive operations. The X9455 operates as a slave in all applications.

All 2-wire interface operations must begin with a START, followed by a Slave Address byte. The Slave Address selects the X9455, and specifies if a Read or Write operation is to be performed.

All Communication over the 2-wire interface is conducted by sending the MSB of each byte of data first.

### Serial Clock and Data

Data states on the SDA line can change only while SCL is LOW. SDA state changes while SCL is HIGH are reserved for indicating START and STOP conditions (See Figure 2). On power up of the X9455, the SDA pin is in the input mode.

### Serial Start Condition

All commands are preceded by the START condition, which is a HIGH to LOW transition of SDA while SCL is HIGH. The device continuously monitors the SDA and SCL lines for the START condition and does not respond to any command until this condition has been met (See Figure 2).

### Serial Stop Condition

All communications must be terminated by a STOP condition, which is a LOW to HIGH transition of SDA while SCL is HIGH. The STOP condition is also used to place the device into the Standby power mode after a read sequence. A STOP condition can only be issued after the transmitting device has released the bus (See Figure 2).

### Serial Acknowledge

An ACK (Acknowledge), is a software convention used to indicate a successful data transfer. The transmitting device, either master or slave, releases the bus after transmitting eight bits. During the ninth clock cycle, the receiver pulls the SDA line LOW to acknowledge the reception of the eight bits of data (See Figure 3).

The device responds with an ACK after recognition of a START condition followed by a valid Slave Address byte. A valid Slave Address byte must contain the Device Type Identifier 0101, and the Device Address bits matching the logic state of pins A2, A1, and A0 (See Figure 4).

If a write operation is selected, the device responds with an ACK after the receipt of each subsequent eight-bit word.

In the read mode, the device transmits eight bits of data, releases the SDA line, and then monitors the line for an ACK. The device continues transmitting data if an ACK is detected. The device terminates further data transmissions if an ACK is not detected. The master must then issue a STOP condition to place the device into a known state.

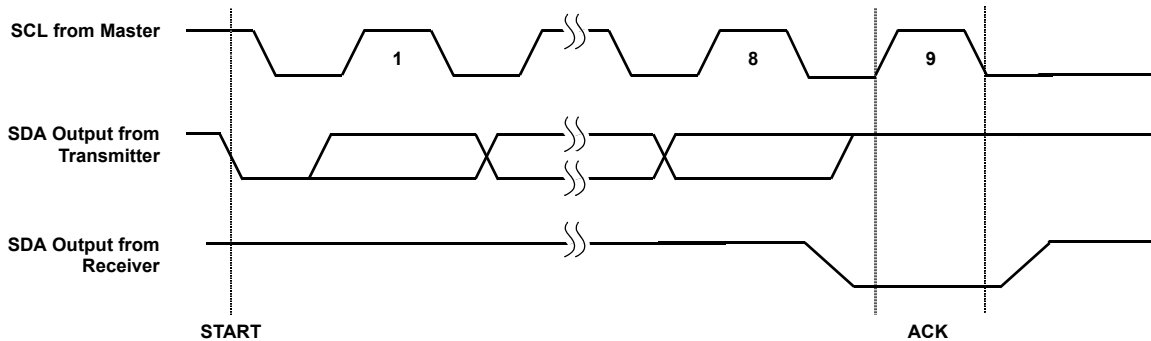
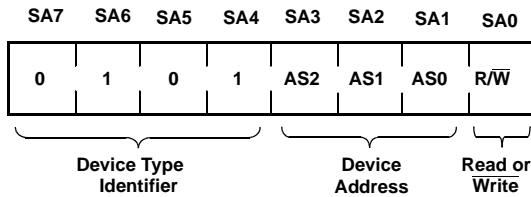

FIGURE 3. ACKNOWLEDGE RESPONSE FROM RECEIVER

**Slave Address Byte**

Following a START condition, the master must output a Slave Address Byte (Refer to figure 4.). This byte includes three parts:

- The four MSBs (SA7-SA4) are the Device Type Identifier, which must always be set to 0101 in order to select the X9455.
- The next three bits (SA3-SA1) are the Device Address bits (AS2-AS0). To access any part of the X9455's memory, the value of bits AS2, AS1, and AS0 must correspond to the logic levels at pins A2, A1, and A0 respectively.
- The LSB (SA0) is the R/W bit. This bit defines the operation to be performed on the device being addressed. When the R/W bit is "1", then a Read operation is selected. A "0" selects a Write operation.



SLAVE ADDRESS BIT(S)	DESCRIPTION
SA7-SA4	Device Type Identifier
SA3-SA1	Device Address
SA0	Read or Write Operation Select

FIGURE 4. SLAVE ADDRESS (SA) FORMAT

**Nonvolatile Write Acknowledge Polling**

After a nonvolatile write command sequence is correctly issued (including the final STOP condition), the X9455 initiates an internal high voltage write cycle. This cycle typically requires 5 ms. During this time, any Read or Write command is ignored by the X9455. Write Acknowledge Polling is used to determine whether a high voltage write cycle is completed.

During acknowledge polling, the master first issues a START condition followed by a Slave Address Byte. The Slave Address Byte contains the X9455's Device Type Identifier and Device Address. The LSB of the Slave Address (R/W) can be set to either 1 or 0 in this case. If the device is busy within the high voltage cycle, then no ACK is returned. If the high voltage cycle is completed, an ACK is returned and the master can then proceed with a new Read or Write operation. (Refer to figure 5.)

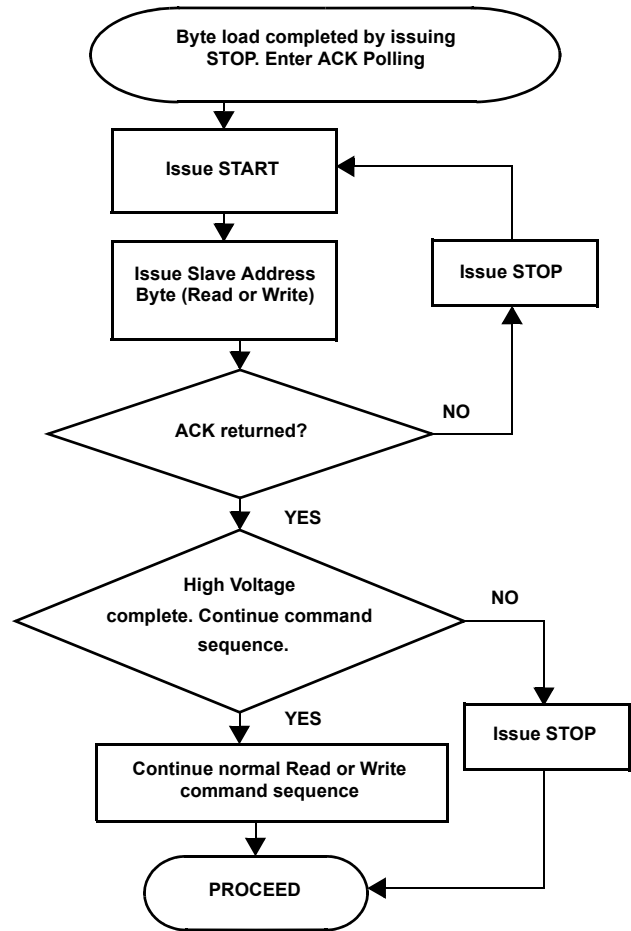

FIGURE 5. ACKNOWLEDGE POLLING SEQUENCE

**2-Wire Serial Interface Operation**

**X9455 Digital Potentiometer Register Organization**

Refer to the Functional Diagram on page 1. There are 2 Digital Potentiometers, referred to as DCP0, and DCP1. Each potentiometer has two volatile Wiper Control Registers (WCRs). Each wiper has four non-volatile registers to store wiper position or general data. See Table 2 for register numbering.

TABLE 3. REGISTER NUMBERING

STATUS REG (NOTE 1) (Addr: 07H)				REGISTERED SELECTED (NOTE 2)			
Reserved bits 7-3	DRSel1 bit 2	DRSel0 bit 1	NVEEnable bit 0	DCP0		DCP2	
				(Addr: 00h)	(Addr: 11h)	(Addr: 02h)	(Addr: 01h)
Reserved	X	X	0	<b>WCR0A</b>	<b>WCR0B</b>	<b>WCR1A</b>	<b>WCR1B</b>
	0	0	1	DR0A0	DR0B0	DR1A0	DR1B0
	0	1	1	DR0A1	DR0B1	DR1A1	DR1B1
	1	0	1	DR0A2	DR0B2	DR1A2	DR1B2
	1	1	1	DR0A3	DR0B3	DR1A3	DR1B3

**NOTES:**To read or write the contents of a single Data Register or Wiper Register:

- Load the status register (using a write command) to select the row.** (See Figure 6.)  
Writing a 1, 3, 5, or 7 to the Status Register specifies that the subsequent read or write command will access a Data Register. This Status Register operation also initiates a transfer of the contents of the selected data register to its associated WCR for all DCPs. So, for example, writing '03h' to the status register causes the value in DR01 to move to WCR0, DR11 to move to WCR1, DR21 to move to WCR2, and DR31 to move to WCR3.  
  
Writing a 0 to bit '0' of the Status Register specifies that the subsequent read or write command will access a Wiper Counter Register. Each WCR can be written to individually, without affecting the contents of any other.
- Access the desired DR or WCR using a new write or read command** (see Figure 7 for write and Figure 9 for read.)  
Specify the desired column (DCP number) by sending the DCP address as part of this read or write command.

The registers are organized in pages of four, with one page consisting of the four volatile WCRs, a second page consisting of the Level 0 Data Registers, and so forth. These pages can be written four bytes at time. In this manner all four potentiometer WCRs can be updated in a single serial write (see Page Write Operation), as well as all four registers of a given page in the DR array.

The unique feature of the X9455 device is that writing or reading to a Data Register of a given wiper automatically updates the WCR of that wiper with the new value. In this manner data can be moved from a particular wiper register to that wiper's WCR just by performing a 2-wire read operation. Simultaneously, that data byte can be utilized by the host.

**Status Register Organization**

The Status Register (SR) is used in read and write operations to select the appropriate wiper register. Before any wiper register can be accessed, the SR must be set to the correct value. It is accessed by setting the Address Byte to 07h. See Table 3. Do this by writing the slave address followed by a byte address of 07h. The SR is volatile and defaults to 00h on power up. It is an 8-bit register containing three control bits in the 3 LSBs as follows:

7	6	5	4	3	2	1	0
Reserved		WCRSel1	WCRSel0	NVEEnable			

Bits WCRSel1 and WCRSel0 determine which Data Register of a wiper is selected for a given operation. NVEEnable is used to select the volatile WCR if "0", and one of the non

volatile wiper registers if "1". Table 3 shows this register organization.

**Wiper Addressing for 2-wire Interface**

Once the Data Register Level has been selected by a 2-wire instruction, then the wiper is determined by the Address Byte of the following instruction. Note again that this enables a complete page write of all four potentiometers at once a particular Wiper Register has been chosen. The register addresses accessible in the X9455 include:

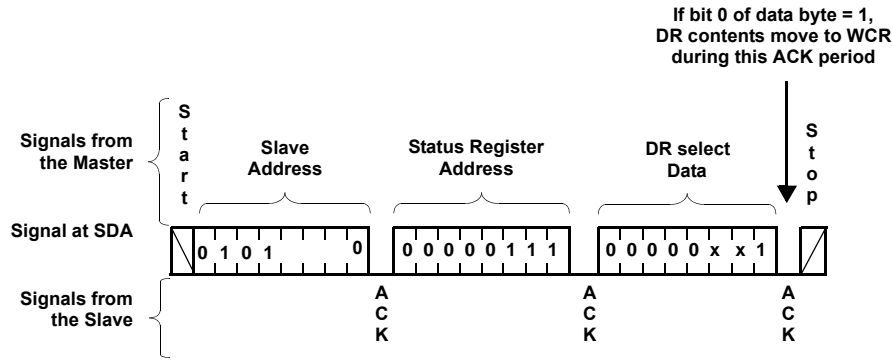

FIGURE 6. STATUS REGISTER WRITE (USES STANDARD BYTE WRITE SEQUENCE TO SET UP ACCESS TO A DATA REGISTER)

TABLE 4. ADDRESSING FOR 2-WIRE INTERFACE ADDRESS BYTE

ADDRESS (HEX)	CONTENTS
0	Wiper 0A
1	Wiper 1B
2	Wiper 1A
3	Wiper 0B
4	Not Used
5	Not Used
6	Not Used
7	Status Register

All other address bits in the address byte must be set to “0” during 2-wire write operations and their value should be ignored when read.

**Byte Write Operation**

For any Byte Write operation, the X9455 requires the Slave Address byte, an Address Byte, and a Data Byte (See Figure 7). After each of them, the X9455 responds with an ACK. The master then terminates the transfer by generating a STOP condition. At this time, if the write operation is to a volatile register (WCR, or SR), the X9455 is ready for the next read or write operation. If the write operation is to a nonvolatile register (DR), and the  $\overline{WP}$  pin is high, the X9455 begins the internal write cycle to the nonvolatile memory. During the internal nonvolatile write cycle, the X9455 does not respond to any requests from the master. The SDA output is at high impedance.

The SR bits and  $\overline{WP}$  pin determine the register being accessed through the 2-wire interface. See Table 2 on page 9.

As noted before, any write operation to a Data Register (DR), also transfers the contents of all the data registers in that row to their corresponding WCR.

For example, to write 3Ahex to the Level 1 Data Register of wiper 1A (DR1A1) the following sequence is required:

```

START
Slave Address  0101 0000  (Hardware Address = 000,
                          and a Write command)
ACK
Address Byte   0000 0111  (Indicates Status Register
                          address)
ACK
Data Byte     0000 0011  (Data Register Level 1 and
                          NVEnable selected)
(note: at this ACK, the WCRs are all updated with their
      respective DR.)
STOP

START
Slave Address  0101 0000  (Hardware address = 000,
                          Write command)
ACK
Address Byte   0000 0010  (Access Wiper 1A)
ACK
Data Byte     0011 1010  (Write Data Byte 3Ah)
ACK
STOP
    
```

During the sequence of this example,  $\overline{WP}$  pin must be high, and A0, A1, and A2 pins must be low. When completed, the DR1A1 register and the WCR1A of Wiper 1A will be set to 3Ah, and the other data registers in Row 1 will transfer their contents to the respective WCRs.

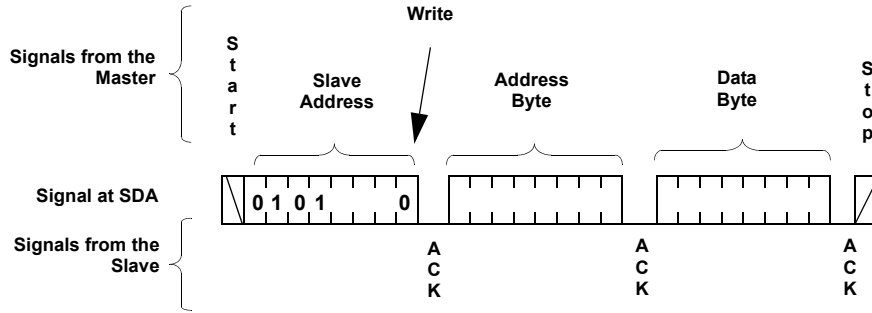

FIGURE 7. BYTE WRITE SEQUENCE

**Page Write Operation**

As stated previously, the memory is organized as a single Status Register (SR), and four pages of four registers each. Each page contains one Data Register for each wiper. Normally a page write operation will be used to efficiently update all four Data Registers and WCR in a single Write command. Note the special sequence for writing to a page: First wiper 0A, then 1B, then 1A, then 0B as shown in Figure 9.

WCR	WCR0A → WCR1B → WCR1A → WCR0B
DR Level 0	DR0A0 → DR1B0 → DR1A0 → DR0B0
DR Level 1	DR0A1 → DR1B1 → DR1A1 → DR0B1
DR Level 2	DR0A2 → DR1B2 → DR1A2 → DR0B2
DR Level 3	DR0A3 → DR1B3 → DR1A3 → DR0B3

FIGURE 8. PAGE WRITE SEQUENCE\*

\*Page writes may wrap around to the first address on a page from the last address.

In order to perform a Page Write operation to the memory array, the NVEnable bit in the SR must first be set to “1”.

A Page Write operation is initiated in the same manner as the Byte Write operation; but instead of terminating the write cycle after the first data byte is transferred, the master can

transmit up to 4 bytes (See Figure 9). After the receipt of each byte, the X9455 responds with an ACK, and the internal WCR address is incremented by one. The page address remains constant. When the address reaches the end of the page, it “rolls over” and goes back to the first byte of the same page.

For example, if the master writes three bytes to a page starting at location DR1A2, the first two bytes are written to locations DR1A2 and DR0B2, while the last byte is written to location DR0A2. Afterwards, the WCR address would point to location DR1B2. If the master supplies more than four bytes of data, then new data overwrites the previous data, one byte at a time.

The master terminates the loading of Data Bytes by issuing a STOP condition, which initiates the nonvolatile write cycle. As with the Byte Write operation, all inputs are disabled until completion of the internal write cycle. If the  $\overline{WP}$  pin is low, the nonvolatile write cycle doesn’t start and the bytes are discarded.

Notice that the Data Bytes are also written to the WCR of the corresponding WCRs, therefore in the above example, WCR1A, WCR0B, and WCR0A are also written, and WCR1B is updated with the contents of DR1B2.

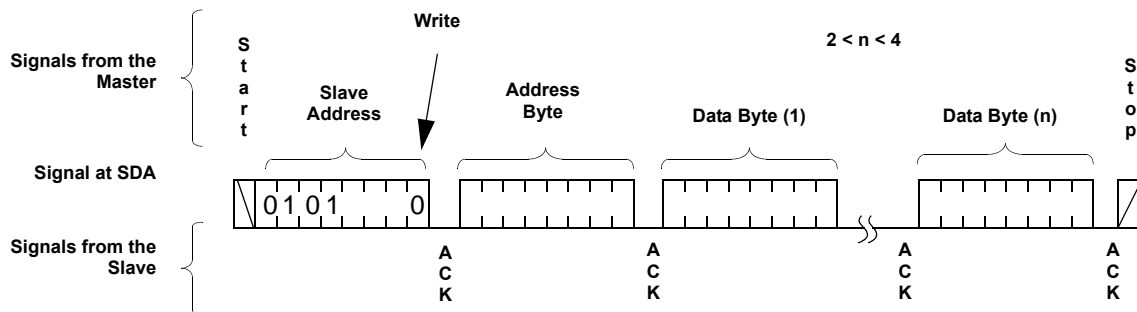

FIGURE 9. PAGE WRITE OPERATION

**Move/Read Operation**

The Move/Read operation simultaneously reads the contents of a data register and moves the contents into the corresponding DCP's WCR and all wipers will have their WCR's updated with the data register values from the row that was read. Move/Read operation consists of a one byte, or three byte instruction followed by one or more Data Bytes (See Figure 10). To read an arbitrary byte, the master initiates the operation issuing the following sequence: a START, the Slave Address byte with the R/W bit set to "0", an Address Byte, a second START, and a second Slave Address byte with the R/W bit set to "1". After each of the three bytes, the X9455 responds with an ACK. Then the X9455 transmits Data Bytes as long as the master responds

with an ACK during the SCL cycle following the eighth bit of each byte. The master terminates the Move/Read operation (issuing a STOP condition) following the last bit of the last Data Byte.

The first byte being read is determined by the current wiper address and by the Status Register bits, according to Table 1 on page 11. If more than one byte is read, the WCR address is incremented by one after each byte, in the same way as during a Page Write operation. After reaching WCR0B, the WCR address "rolls over" to WCR0A.

On power up, the Address pointer is set to the Data Register 0 of WCR0A.

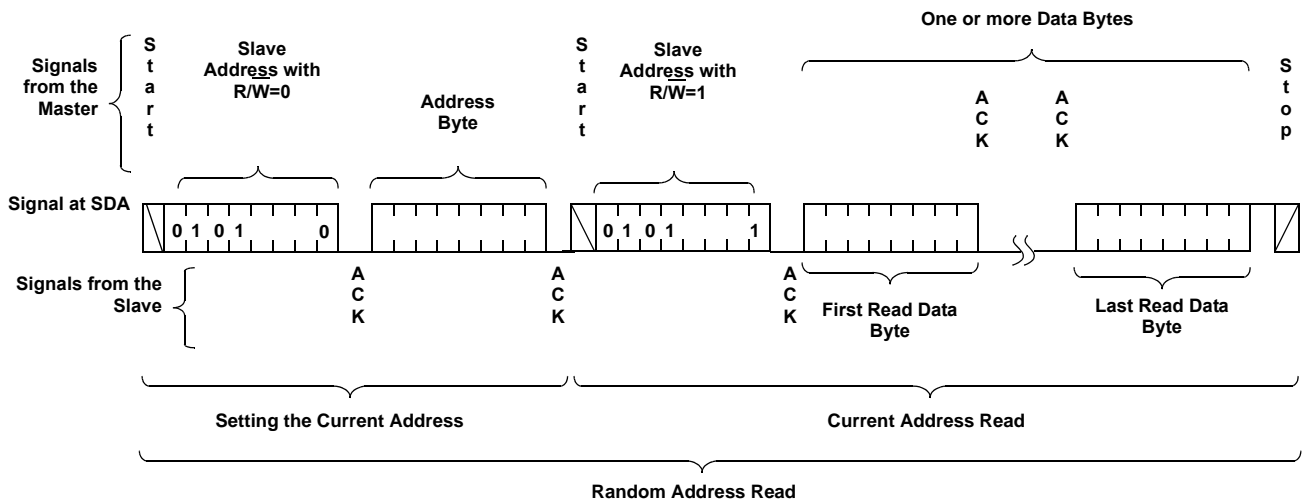
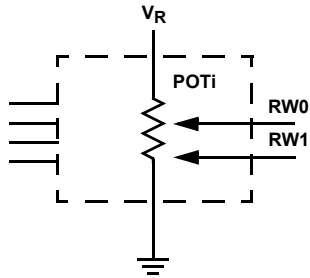

FIGURE 10. MOVE/READ SEQUENCE

**Applications information**

**Basic Configurations of Electronic Potentiometers**



Four terminal Potentiometer;  
Variable voltage divider

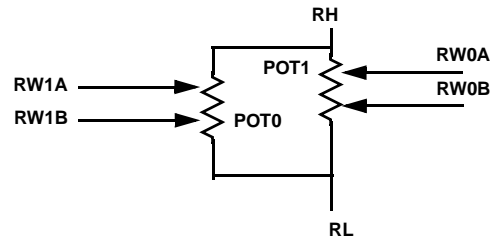

Four-Wiper DCP

**Application Circuits**

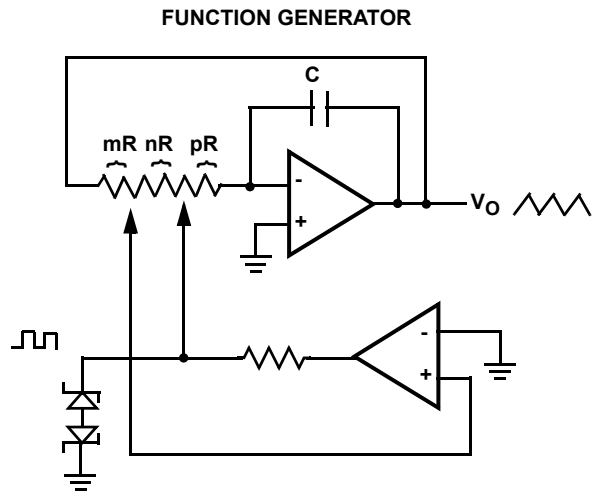
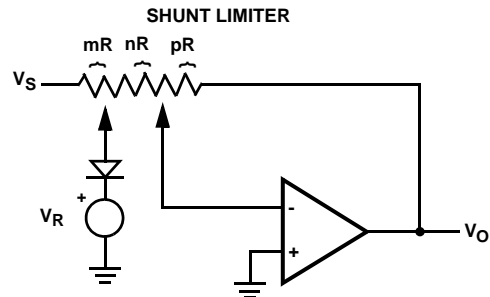
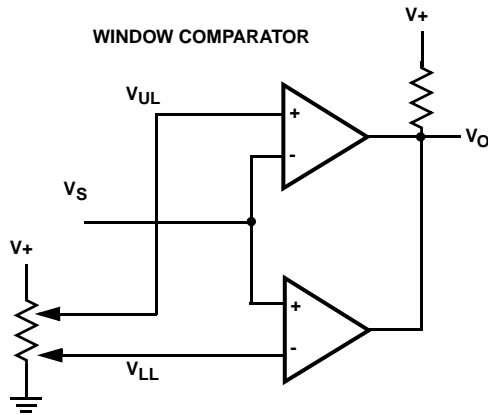



PROGRAMMABLE STATE VARIABLE FILTER

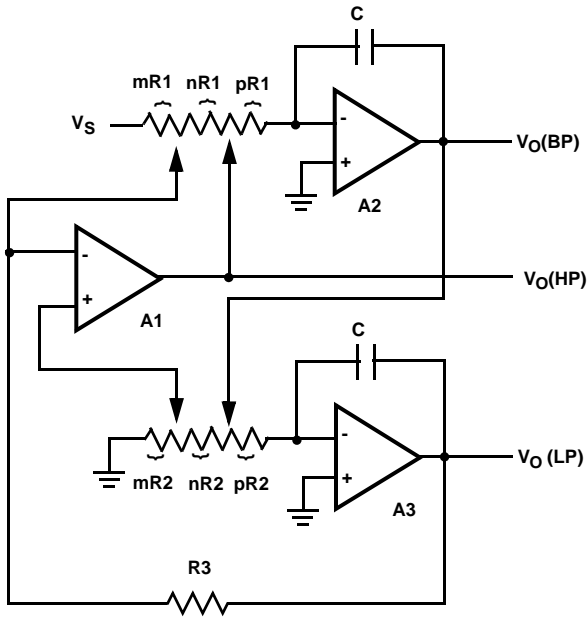

PROGRAMMABLE LADDER NETWORKS

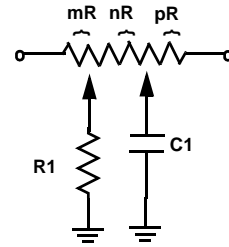

WIEN BRIDGE OSCILLATOR

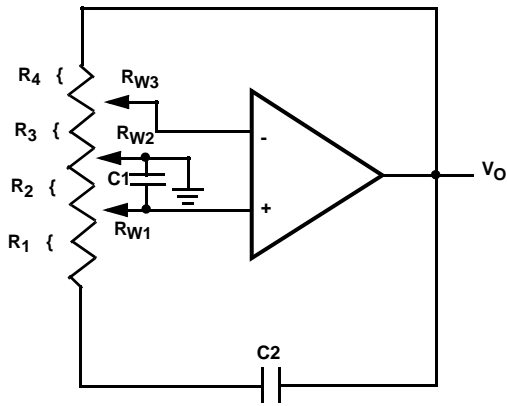

GENERALIZED IMPEDANCE CONVERTER

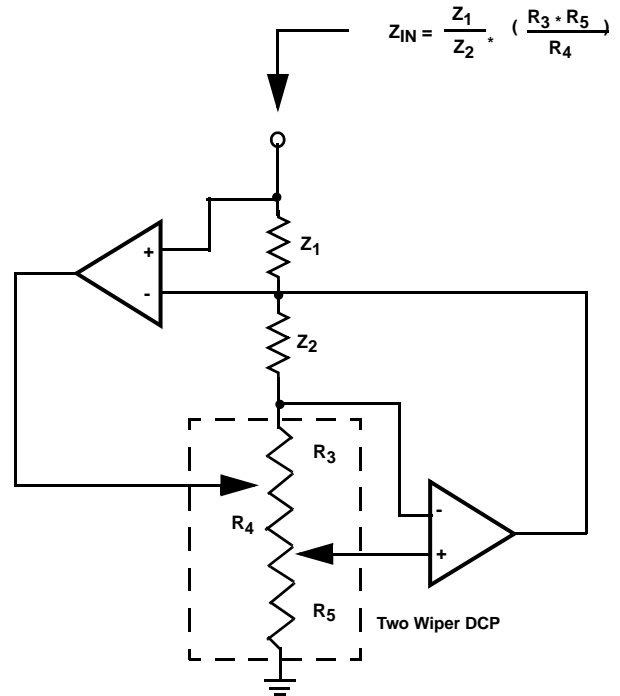

PACKAGING INFORMATION

24-Lead Plastic, TSSOP, Package Code V24

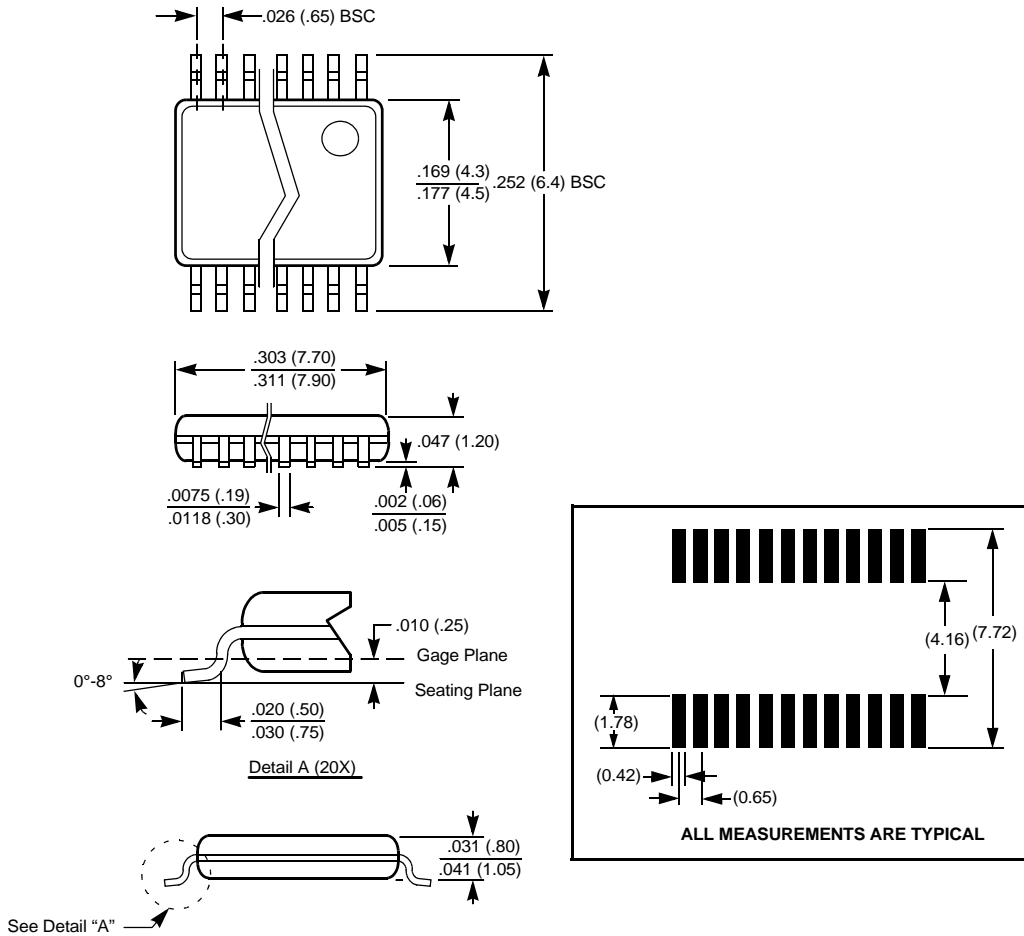

NOTE: ALL DIMENSIONS IN INCHES (IN PARENTHESES IN MILLIMETERS)

All Intersil U.S. products are manufactured, assembled and tested utilizing ISO9000 quality systems. Intersil Corporation's quality certifications can be viewed at [www.intersil.com/design/quality](http://www.intersil.com/design/quality)

*Intersil products are sold by description only. Intersil Corporation reserves the right to make changes in circuit design, software and/or specifications at any time without notice. Accordingly, the reader is cautioned to verify that data sheets are current before placing orders. Information furnished by Intersil is believed to be accurate and reliable. However, no responsibility is assumed by Intersil or its subsidiaries for its use; nor for any infringements of patents or other rights of third parties which may result from its use. No license is granted by implication or otherwise under any patent or patent rights of Intersil or its subsidiaries.*

For information regarding Intersil Corporation and its products, see [www.intersil.com](http://www.intersil.com)

Copyright © Each Manufacturing Company.

All Datasheets cannot be modified without permission.

This datasheet has been download from :

[www.AllDataSheet.com](http://www.AllDataSheet.com)

100% Free DataSheet Search Site.

Free Download.

No Register.

Fast Search System.

[www.AllDataSheet.com](http://www.AllDataSheet.com)