

Fibre Channel Coaxial Cable Driver and Loop Resiliency Circuit

The MC10SX1189 is a differential receiver, differential transmitter specifically designed to drive coaxial cables. It incorporates the output cable drive capability of the MC10EL89 Coaxial Cable Driver with additional circuitry to multiplex the output cable drive source between the cable receiver or the local transmitter inputs. The multiplexer control circuitry is TTL compatible for ease of operation.

- 425ps Propagation Delay
- 1.6V Output Swing on the Cable Driving Output
- Single +5V operation
- 75kΩ Internal Input Pull Down Resistors
- >1000 Volt ESD Protection

The MC10SX1189 is useful as a bypass element for Fibre Channel-Arbitrated Loop (FC-AL) or Serial Storage Architecture (SSA) applications, to create loop style interconnects with fault tolerant, active switches at each device node. This device is particularly useful for back panel applications where small size is desirable.

The EL89 style drive circuitry produces swings twice as large as a standard PECL output. When driving a coaxial cable, proper termination is required at both ends of the line to minimize reflections. The 1.6V output swings allow for proper termination at both ends of the cable, while maintaining the required swing at the receiving end of the cable. Because of the larger output swings, the QT, QT outputs are terminated into the thevenin equivalent of 50Ω to V_{CC} - 3.0V instead of 50Ω to V_{CC} - 2.0V.

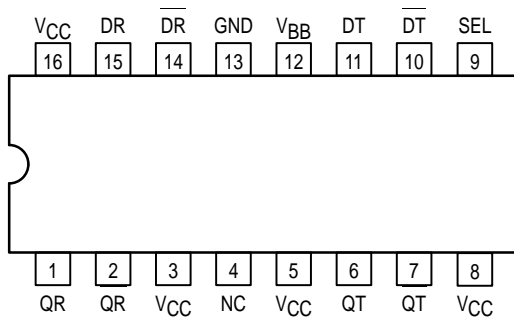

Pinout: 16-Lead SOIC (Top View)

MC10SX1189

FIBRE CHANNEL COAXIAL CABLE DRIVER AND LOOP RESILIENCY CIRCUIT

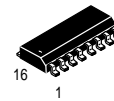

D SUFFIX
PLASTIC SOIC PACKAGE
CASE 751B-05

TRUTH TABLE

SEL	Function
L	DR → QT
H	DT → QT

PIN NAMES

Pins	Function
DR/ <u>DR</u> QR/ <u>QR</u>	Differential Input from Receive Cable Buffered Differential Output from Receive Cable
<u>DT</u> / <u>DT</u> QT/ <u>QT</u>	Differential Input to Transmit Cable Buffered Differential Output to Transmit Cable
SEL	Multiplexer Control Signal (TTL)
V _{CC}	Positive Power Supply
GND	Ground
V _{BB}	Reference Voltage Output



LOGIC DIAGRAM

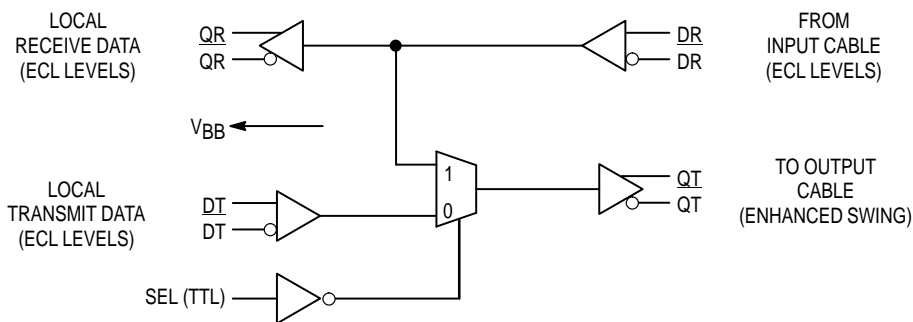

ABSOLUTE MAXIMUM RATINGS*

Symbol	Parameter	Value	Unit
V _{CC}	Power Supply Voltage (Referenced to GND)	0 to +7.0	Vdc
V _{IN}	Input Voltage (Referenced to GND)	0 to +6.0	Vdc
I _{OUT}	Output Current	50 100	mA
T _A	Operating Temperature Range	-40 to +85	°C
T _{STG}	Storage Temperature Range	-50 to +150	°C
V _{CC}	Operating Voltage Range ¹	4.5 to 5.5	Vdc

* Absolute Maximum Ratings are those values beyond which damage to the device may occur. Functional operation should be restricted to the Recommended Operating Conditions.

1. Parametric values specified at 4.75 to 5.25V.

DC CHARACTERISTICS¹

Symbol	Characteristic	-40°C			0°C			25°C			85°C			Unit
		Min	Typ	Max	Min	Typ	Max	Min	Typ	Max	Min	Typ	Max	
V _{OH}	Output Voltage High (QR,QR) V _{CC} = 5.0V, GND = 0V (Notes 2,3)	3.92	4.05	4.11	3.98	4.09	4.16	4.02	4.11	4.19	4.09	4.16	4.28	V
V _{OL}	Output Voltage Low (QR,QR) V _{CC} = 5.0V, GND = 0V (Notes 2,3)	3.05	3.23	3.35	3.05	3.24	3.37	3.05	3.24	3.37	3.05	3.25	3.41	V
V _{OH}	Output Voltage High (QT,QT) V _{CC} = 5.0V, GND = 0V (Notes 2,4)	3.71	3.89	4.08	3.79	3.98	4.17	3.83	4.02	4.20	3.90	4.09	4.28	V
V _{OL}	Output Voltage Low (QT,QT) V _{CC} = 5.0V, GND = 0V (Notes 2,4)	1.94	2.22	2.50	1.83	2.12	2.41	1.80	2.10	2.39	1.77	2.06	2.35	V
I _{CC}	Quiescent Supply Current (Note 5)	20	25	42	22	26	47	23	27	47	25	28	47	mA
V _{IH}	Input Voltage High (DR,DR & DT,DT) V _{CC} = 5.0V, GND = 0V (Note 2)	3.77		4.11	3.83		4.16	3.87		4.19	3.94		4.28	V
V _{IL}	Input Voltage Low (DR,DR & DT,DT) V _{CC} = 5.0V, GND = 0V (Note 2)	3.05		3.50	3.05		3.52	3.05		3.52	3.05		3.56	V
V _{IH}	Input Voltage High SEL	2.0			2.0			2.0			2.0			V
V _{IL}	Input Voltage Low SEL			0.8			0.8			0.8			0.8	V
V _{BB}	Output Reference Voltage V _{CC} = 5.0V, GND = 0V (Note 2)	3.57	3.63	3.70	3.62	3.67	3.73	3.65	3.70	3.75	3.69	3.75	3.81	V

1. 10SX circuits are designed to meet the DC specifications shown in the table after thermal equilibrium has been established. The circuit is mounted in a test socket or mounted on a printed circuit board and transverse air greater than 500lfm is maintained.

2. Values will track 1:1 with the V_{CC} supply.

3. Outputs loaded with 50Ω to +3.0V

4. Outputs loaded with 50Ω to +2.0V

5. Outputs open circuited.

AC CHARACTERISTICS¹ ($V_{CC} = 4.75$ to $5.25V$)

Symbol	Characteristic	-40°C			0 to 85°C			Unit	Condition
		Min	Typ	Max	Min	Typ	Max		
t_{PLH} , t_{PHL}	Propagation Delay to Output DR → QR (Diff) (SE) DR → QT (Diff) (SE) DT → QT (Diff) (SE)	175	300	450	225	325	500	ps	Note 2 Note 3
		150	300	500	175	325	550		
		250 225	425 425	650 700	300 250	450 450	650 700		
t_{PLH} , t_{PHL}	Propagation Delay SEL → QT,QT	450	600	850	500	650	800	ps	1.5V to 50% Pt
t_r , t_f	Rise Time Fall Time	100	275	400	125	275	400	ps	20% to 80%
	QR,QR	100	275	400	125	275	400		80% to 20%
t_r , t_f	Rise Time Fall Time	150	300	550	150	300	550	ps	20% to 80%
	QT,QT	150	300	550	150	300	550		80% to 20%
t_{skew}	Within Device Skew		15			15		ps	Note 4
V_{PP}	Minimum Input Swing	200			200			mV	Note 5
V_{CMR}	Common Mode Range	3.00		4.35	3.00		4.35	V	Note 6

1. 10SX circuits are designed to meet the AC specifications shown in the table after thermal equilibrium has been established. The circuit is mounted in a test socket or mounted on a printed circuit board and transverse air greater than 500lfm is maintained.

2. The differential propagation delay is defined as the delay from the crossing points of the differential input signals to the crossing point of the differential output signals.

3. The single-ended propagation delay is defined as the delay from the 50% point of the input signal to the 50% point of the output signal.

4. Duty cycle skew is the difference between t_{PLH} and t_{PHL} propagation delay through a device, Stretch input is left open.

5. Minimum input swing for which AC parameters are guaranteed.

6. The CMR range is referenced to the most positive side of the differential input signal. Normal operation is obtained if the HIGH level falls within the specified range and the peak-to-peak voltage lies between $V_{PP\ Min}$ and 1.0V.

OUTLINE DIMENSIONS

D SUFFIX
PLASTIC PACKAGE
CASE 751B-05
ISSUE J

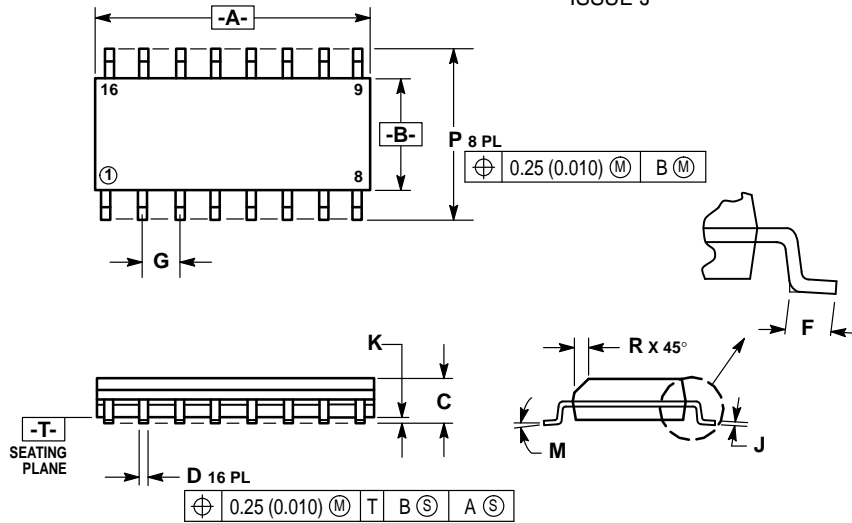

- NOTES:
1. DIMENSIONING AND TOLERANCING PER ANSI Y14.5M, 1982.
 2. CONTROLLING DIMENSION: MILLIMETER.
 3. DIMENSIONS A AND B DO NOT INCLUDE MOLD PROTRUSION.
 4. MAXIMUM MOLD PROTRUSION 0.15 (0.006) PER SIDE.
 5. DIMENSION D DOES NOT INCLUDE DAMBAR PROTRUSION. ALLOWABLE DAMBAR PROTRUSION SHALL BE 0.127 (0.005) TOTAL IN EXCESS OF THE D DIMENSION AT MAXIMUM MATERIAL CONDITION.

DIM	MILLIMETERS		INCHES	
	MIN	MAX	MIN	MAX
A	9.80	10.00	0.386	0.393
B	3.80	4.00	0.150	0.157
C	1.35	1.75	0.054	0.068
D	0.35	0.49	0.014	0.019
F	0.40	1.25	0.016	0.049
G	1.27 BSC		0.050 BSC	
J	0.19	0.25	0.008	0.009
K	0.10	0.25	0.004	0.009
M	0°	7°	0°	7°
P	5.80	6.20	0.229	0.244
R	0.25	0.50	0.010	0.019

Motorola reserves the right to make changes without further notice to any products herein. Motorola makes no warranty, representation or guarantee regarding the suitability of its products for any particular purpose, nor does Motorola assume any liability arising out of the application or use of any product or circuit, and specifically disclaims any and all liability, including without limitation consequential or incidental damages. "Typical" parameters can and do vary in different applications. All operating parameters, including "Typicals" must be validated for each customer application by customer's technical experts. Motorola does not convey any license under its patent rights nor the rights of others. Motorola products are not designed, intended, or authorized for use as components in systems intended for surgical implant into the body, or other applications intended to support or sustain life, or for any other application in which the failure of the Motorola product could create a situation where personal injury or death may occur. Should Buyer purchase or use Motorola products for any such unintended or unauthorized application, Buyer shall indemnify and hold Motorola and its officers, employees, subsidiaries, affiliates, and distributors harmless against all claims, costs, damages, and expenses, and reasonable attorney fees arising out of, directly or indirectly, any claim of personal injury or death associated with such unintended or unauthorized use, even if such claim alleges that Motorola was negligent regarding the design or manufacture of the part. Motorola and (M) are registered trademarks of Motorola, Inc. Motorola, Inc. is an Equal Opportunity/Affirmative Action Employer.

How to reach us:

USA/EUROPE: Motorola Literature Distribution;
P.O. Box 20912; Phoenix, Arizona 85036. 1-800-441-2447

JAPAN: Nippon Motorola Ltd.; Tatsumi-SPD-JLDC, Toshikatsu Otsuki,
6F Seibu-Butsuryu-Center, 3-14-2 Tatsumi Koto-Ku, Tokyo 135, Japan. 03-3521-8315

MFAX: RMFAX0@email.sps.mot.com -TOUCHTONE (602) 244-6609
INTERNET: http://Design-NET.com

HONG KONG: Motorola Semiconductors H.K. Ltd.; 8B Tai Ping Industrial Park,
51 Ting Kok Road, Tai Po, N.T., Hong Kong. 852-26629298



Copyright © Each Manufacturing Company.

All Datasheets cannot be modified without permission.

This datasheet has been download from :

www.AllDataSheet.com

100% Free DataSheet Search Site.

Free Download.

No Register.

Fast Search System.

www.AllDataSheet.com