



MAX1575 Evaluation Kit

Evaluates: MAX1575

General Description

The MAX1575 evaluation kit (EV kit) is a fully assembled and tested circuit for evaluating the MAX1575 white LED 1x/1.5x charge pump. The MAX1575 drives 4 white LEDs in a main display group and 2 white LEDs in a sub-group. These 6 surface-mount white LEDs are included on the EV kit. In addition to the LED driver circuit, the EV kit includes two pulse-generator circuits on the left side of the PC board that are used for testing the single-wire serial pulse-dimming feature of the MAX1575.

Component List

DESIGNATION	QTY	DESCRIPTION
C1-C4	4	1 μ F \pm 20%, 6.3V X5R ceramic capacitors (0402) Panasonic ECJ0EB0J105M or TDK C1005X5R0J105M or equivalent
C5, C8	2	2.2 μ F \pm 10%, 6.3V X5R ceramic capacitors (0603) Panasonic ECJ1VB0J225K or TDK C1608X5R0J225K or equivalent
C6, C7	2	0.01 μ F \pm 10%, X7R ceramic capacitors (0402) TDK C1005X7R1E103K or equivalent
D1-D6	6	White surface-mount right-angle LEDs Nichia NSCW215T
D7, D8	2	Diodes (SOD-323) Central CMMDD4448
JU1	0	Not installed, PC board short
JU2, JU3	2	3-pin headers
R1	1	6.81k Ω \pm 1% resistor (0402)
R2, R3	2	10k Ω \pm 5% resistors (0402)
S1, S2	2	Momentary pushbutton switches Panasonic EVQ-PHP03T
U1	1	Maxim MAX1575ETE (16 thin QFN 4mm x 4mm)
U2, U3	2	MAX6818EUS-T (4-pin SOT143)
—	2	Shunt, 2 position

Features

- ◆ Powers 4 Main and 2 Sub-Display LEDs
- ◆ Average 85% Efficiency (P_{LED} / P_{BATT}) over Li+ Battery Discharge
- ◆ 1.5% LED Current Matching
- ◆ Adaptive 1x/1.5x Mode Switchover
- ◆ Low Input Ripple and EMI
- ◆ Individual 5% to 100% Brightness Single-Wire Serial Pulse Dimming
- ◆ 2.7V to 5.5V Supply Voltage Range
- ◆ Thin QFN 4mm x 4mm IC Package
- ◆ Fully Assembled and Tested

Ordering Information

PART	TEMP RANGE	IC PACKAGE
MAX1575EVKIT	0°C to +70°C	16 Thin QFN (4mm x 4mm)

Quick Start

Recommended Equipment

A 2.7V to 5.5V power supply or battery capable of delivering 200mA.

Procedure

Follow the steps below to verify board operation.

- 1) Verify that shunts are connected across pins 1-2 of jumpers JU2 and JU3.
- 2) Preset the power supply to between 2.7V and 5.5V.
- 3) Turn off the power supply. Do not turn on the power supply until all connections are completed.
- 4) Connect the positive power supply terminal to the pad on the EV kit labeled IN.
- 5) Connect the power supply ground terminal to the pad on the EV kit labeled GND.
- 6) Turn on the power supply and verify that the LEDs are lit.

See the *Detailed Description* section for testing the dimming and shutdown features.

MAX1575 Evaluation Kit

Component Suppliers

SUPPLIER	PHONE	WEBSITE
Central Semiconductor	631-435-1110	www.centralsemi.com
Kamaya	260-489-1533	www.kamaya.com
Murata	814-237-1431	www.murata.com
Nichia	248-352-6575	www.nichia.com
Panasonic	714-373-7939	www.panasonic.com
Taiyo Yuden	408-573-4150	www.t-yuden.com
TDK	847-803-6100	www.component.tdk.com
Vishay	402-563-6866	www.vishay.com

Note: Indicate that you are using the MAX1575 when contacting these component suppliers.

Detailed Description

LED Dimming

To test the dimming feature, press the button labeled DIM MAIN or DIM SUB. Each of the first nine button presses dims the corresponding group of LEDs by 10%. The tenth press dims the LEDs by 5%, and the eleventh press returns the LEDs to full brightness. Refer to the MAX1575 data sheet for more information on the dimming feature.

Using External Pulse Generators for Dimming

To use external pulse generators in place of the pulse generators included with the EV kit, simply connect the outputs of the external pulse generators to EN_MAIN for the main display dimming, and EN_SUB for the sub-display dimming. The grounds of the external pulse generators should be connected to the EV kit pad labeled GND. Short pins 1-2 of jumpers JU2 and JU3. Note that there are 10k Ω pullup resistors from EN_MAIN and EN_SUB to IN on the EV kit.

Adjusting the 100% Brightness Level

The full-brightness LED current is adjusted by changing the resistor R1. Calculate the value of R1 with the following equation, where $I_{LED_}$ is the current through one of the LEDs with the dimming set to 100%.

$$R1 = \frac{0.6V \times 234}{I_{LED_}}$$

Shutdown

Two jumpers are included on the EV kit for shutting down each of the displays. To turn off the main LED group, short pins 2-3 of JU2. To turn off the sub-LED group, short pins 2-3 of JU3. Note that with pins 2-3 of JU2 or JU3 shorted, power is disconnected from the corresponding pulse-generator circuit on the left side of the board. To place the MAX1575 in low-power shutdown mode and disconnect power from both pulse-generator circuits, short pins 2-3 of both JU2 and JU3.

Changing the Number of LEDs

The EV kit comes with 6 LEDs installed, 4 for the main display and 2 for the sub-display. To use fewer LEDs, locate the small pad next to the LED to be removed and connect it to the pad on the EV kit labeled IN.

Connecting External LEDs

To connect external LEDs to the MAX1575 EV kit, cut the trace shorting JU1. Connect the anodes of all the external LEDs to the small pad labeled OUT. Connect the cathodes to the small pads next to D1–D6 (D1–D4 for the main LEDs, D5–D6 for the sub-LEDs). Connect any unused pads (D1–D6) to IN.

MAX1575 Evaluation Kit

Evaluates: MAX1575

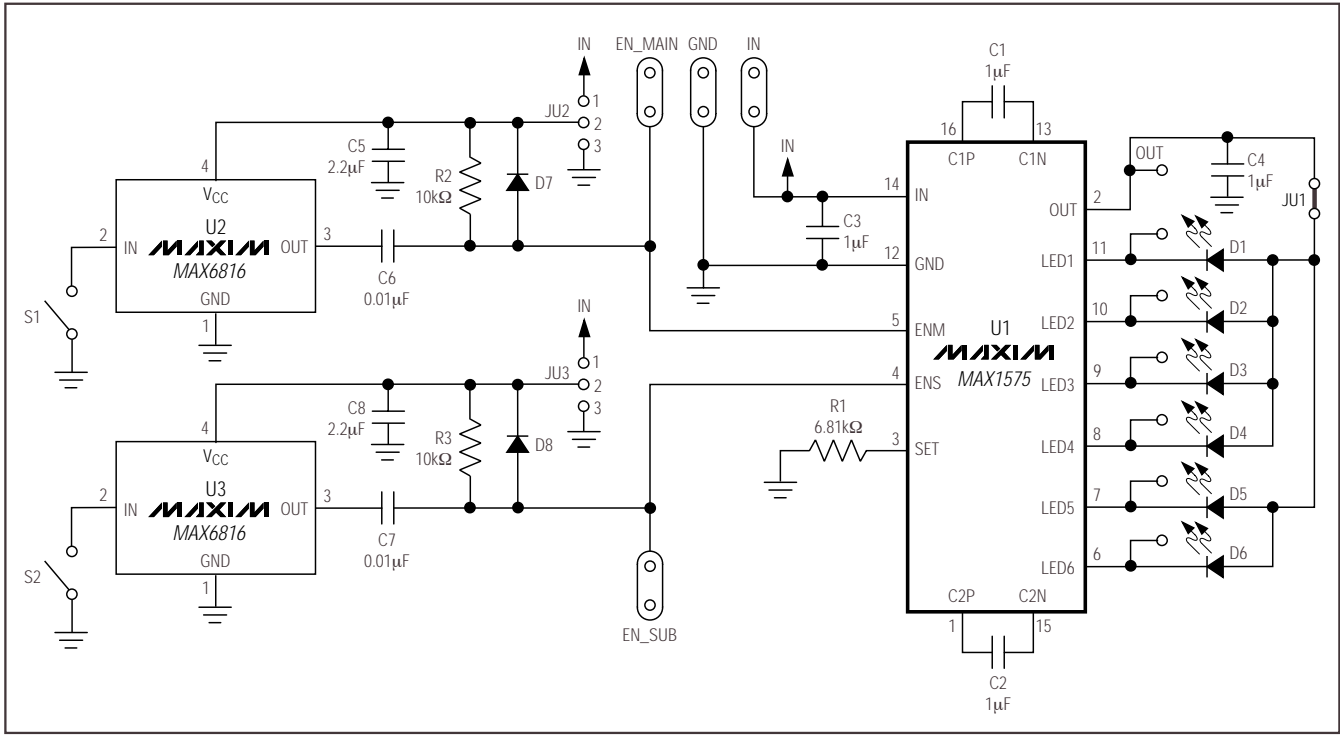

Figure 1. MAX1575 EV Kit Schematic

MAX1575 Evaluation Kit

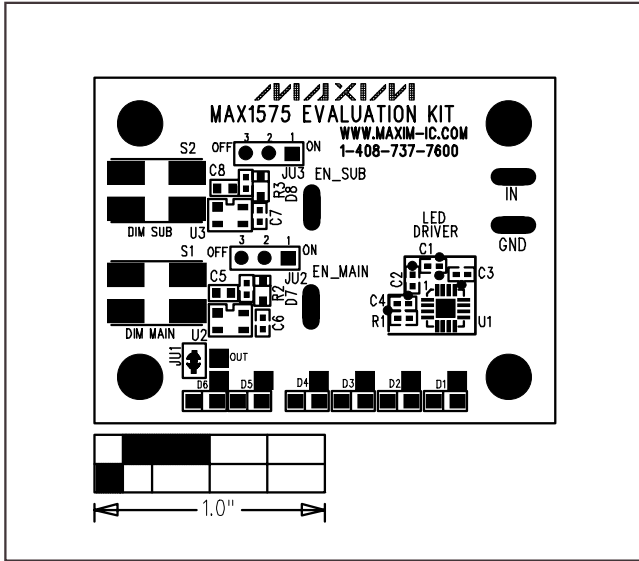

Figure 2. MAX1575 EV Kit Component Placement Guide—Component Side

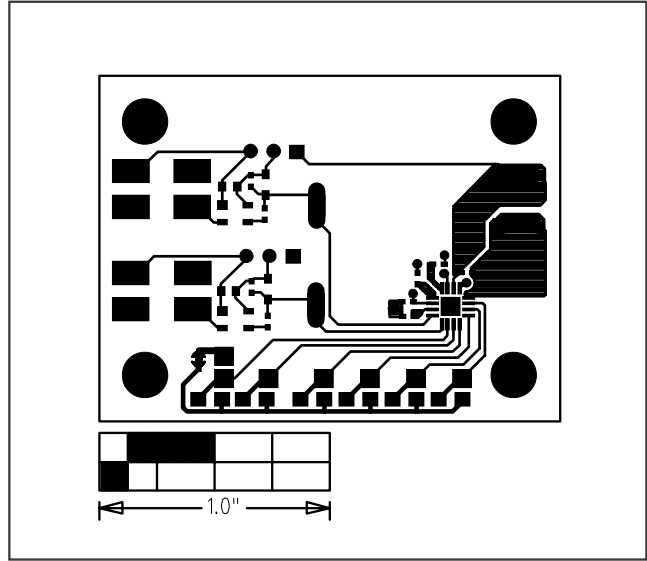

Figure 3. MAX1575 EV Kit Layout—Component Side

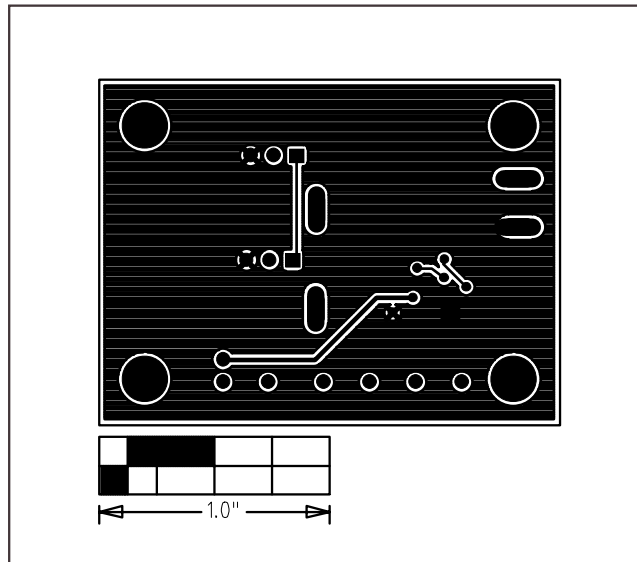

Figure 4. MAX1575 EV Kit Layout—Solder Side

Maxim cannot assume responsibility for use of any circuitry other than circuitry entirely embodied in a Maxim product. No circuit patent licenses are implied. Maxim reserves the right to change the circuitry and specifications without notice at any time.

4 _____ Maxim Integrated Products, 120 San Gabriel Drive, Sunnyvale, CA 94086 408-737-7600

Copyright © Each Manufacturing Company.

All Datasheets cannot be modified without permission.

This datasheet has been download from :

www.AllDataSheet.com

100% Free DataSheet Search Site.

Free Download.

No Register.

Fast Search System.

www.AllDataSheet.com