

EVALUATION KIT  
AVAILABLE



# High-Efficiency, 26V Step-Up Converter for White LED Main and Subdisplay Backlighting

MAX1582

## General Description

The MAX1582 drives up to six white LEDs in series with a constant current to provide display backlighting for two (main and sub-) displays in cell phones and other hand-held devices. This configuration eliminates the need for ballast resistors and expensive factory calibration. The proprietary dual-output, step-up pulse-width modulation (PWM) converter includes a 30V, low  $R_{DS(on)}$  N-channel MOSFET switch for high efficiency and maximum battery life.

The MAX1582 utilizes 1MHz current-mode PWM control to allow small input and output capacitors and a small inductor, while minimizing ripple on the input supply and avoiding interference to sensitive circuitry in the equipment. Integrated overvoltage protection eliminates the need for an external zener diode to protect the IC from open circuit. Flexible dimming control utilizes either an analog control signal or direct digital PWM control without external RC filtering. This also increases dimming accuracy at low brightness levels. The PWM dimming signal can be any frequency from 200Hz to 200kHz. Soft-start eliminates inrush current during startup.

The MAX1582 is available in tiny 4 × 4 chip-scale (UCSP™) and 12-pin thin QFN packages.

## Applications

- Cell Phones with One or Two Displays
- Smart Phones, Palmtops, and Wireless Handhelds
- Other Hand-Held Devices with Dual Displays

## Typical Application Circuit

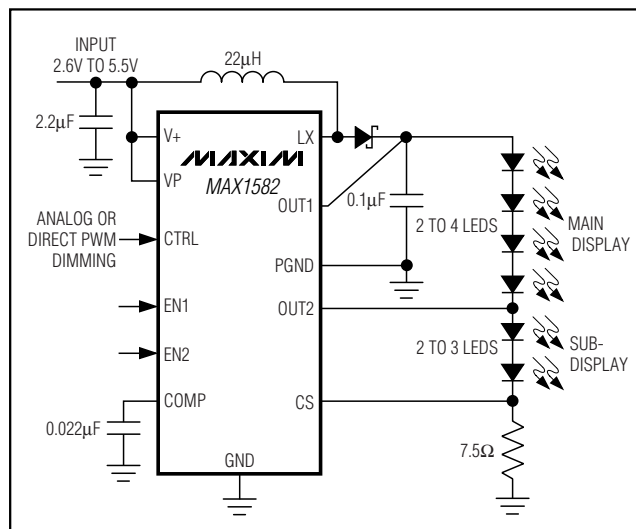

## Features

- ◆ Accurate Current Regulation for Uniform Illumination
- ◆ Lights Up Two LED Sections for Main and Subdisplays
- ◆ Up to 84% Efficiency
- ◆ Internal High-Power, 30V MOSFET
- ◆ Low 15mV<sub>p-p</sub> Input Ripple
- ◆ Flexible Dimming Control
  - Analog DAC Controlled
  - Direct-Digital PWM (No RC Required) from 200Hz to 200kHz
- ◆ Overvoltage Protection to Eliminate Zener Diode
- ◆ Constant 1MHz PWM Operation
- ◆ Low-Profile Inductor and Capacitors
- ◆ Soft-Start Eliminates Inrush Current
- ◆ 2.6V to 5.5V Input
- ◆ 0.01µA (typ) Shutdown Current
- ◆ Tiny UCSP (2.1mm × 2.1mm × 0.61mm) and Thin QFN (4mm × 4mm) Packages

## Ordering Information

PART	TEMP RANGE	PIN-PACKAGE	TOP MARK
MAX1582ETC	-40°C to +85°C	12 Thin QFN-EP*	AACE
MAX1582EBE-T	-40°C to +85°C	16 UCSP-16	1582EBE

\*EP = Exposed paddle.

UCSP is a trademark of Maxim Integrated Products, Inc.

## Pin Configurations

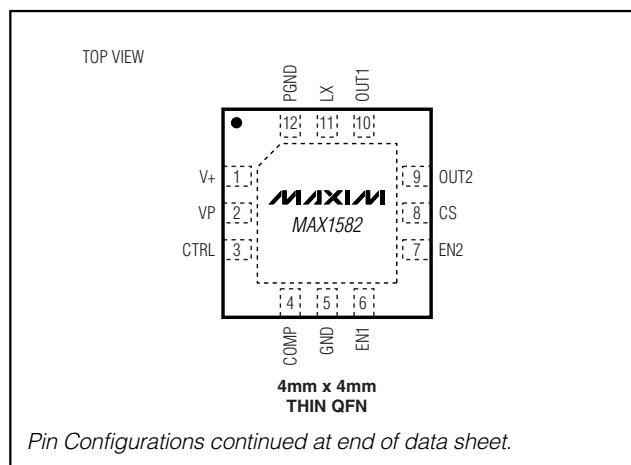

# High-Efficiency, 26V Step-Up Converter for White LED Main and Subdisplay Backlighting

## ABSOLUTE MAXIMUM RATINGS

V+, VP, CTRL to GND	-0.3V to +6.0V
PGND to GND	-0.3V to +0.3V
LX, OUT1 to GND	-0.3V to +30V
OUT2 to GND	-0.3V to +14V
COMP, CS, EN1, EN2 to GND	-0.3V to (V <sub>V+</sub> + 0.3V)
I <sub>LX</sub>	1A <sub>RMS</sub>

Continuous Power Dissipation (T <sub>A</sub> = +70°C)	
12-Pin Thin QFN (derate 16.9mW/°C above +70°C)	1349mW
16-Pin UCSP (derate 6.5mW/°C above +70°C)	518mW
Operating Temperature Range	-40°C to +85°C
Junction Temperature	+150°C
Storage Temperature Range	-65°C to +150°C
Lead Temperature (soldering, 10s)	+300°C

Stresses beyond those listed under "Absolute Maximum Ratings" may cause permanent damage to the device. These are stress ratings only, and functional operation of the device at these or any other conditions beyond those indicated in the operational sections of the specifications is not implied. Exposure to absolute maximum rating conditions for extended periods may affect device reliability.

## ELECTRICAL CHARACTERISTICS

(V<sub>V+</sub> = +3.0V, V<sub>OUT1</sub> = 20V, L1 = 22μH, C<sub>OUT</sub> = 0.1μF, C<sub>COMP</sub> = 0.022μF, R<sub>SENSE</sub> = 7.5Ω, V<sub>CTRL</sub> = +1.5V, EN1 = EN2 = V+, T<sub>A</sub> = 0°C to +85°C, unless otherwise noted. Typical values are at T<sub>A</sub> = +25°C.) (Note 1)

PARAMETER	CONDITIONS	MIN	TYP	MAX	UNITS
Supply Voltage		2.6		5.5	V
Undervoltage Lockout (UVLO) Threshold	V <sub>V+</sub> rising or falling	2.10	2.38	2.55	V
UVLO Hysteresis			40		mV
Quiescent Current	No switching, V <sub>CTRL</sub> = V <sub>CS</sub> = +0.25V		0.40	0.56	mA
Shutdown Supply Current	EN1 = EN2 = GND, OUT1 = V <sub>V+</sub>				μA
	T <sub>A</sub> = +25°C		0.01	1	
	T <sub>A</sub> = +85°C		0.1		
Overvoltage Lockout (OVLO) Threshold		26	27	29	V
OVLO Hysteresis			2		V
OUT1 Input Bias Current	V <sub>OUT1</sub> = +26V, EN1 = EN2 = V <sub>V+</sub>	20	40	65	μA
	OUT1 = V <sub>V+</sub> , EN1 = EN2 = GND				
	T <sub>A</sub> = +25°C		0.01	1	
	T <sub>A</sub> = +85°C		0.05		
Output Voltage Range	(Note 2)		(V <sub>V+</sub> - V <sub>DIODE</sub> )	25.5	V
<b>ERROR AMPLIFIER</b>					
CTRL to CS Regulation	V <sub>CTRL</sub> = +1.0V, V <sub>V+</sub> = +2.6V to +5.5V	0.095	0.100	0.106	V
CS Input Bias Current	V <sub>CS</sub> = V <sub>CTRL</sub> / 10				μA
	T <sub>A</sub> = +25°C		0.01	1	
	T <sub>A</sub> = +85°C		1		
CTRL Input Resistance	0 < V <sub>CTRL</sub> < +1V	290	500	780	kΩ
CS to COMP Transconductance	V <sub>COMP</sub> = +1.0V	32	50	82	μS
<b>OSCILLATOR</b>					
Operating Frequency		0.80	1.0	1.25	MHz
Minimum Duty Cycle	PWM mode		12		%
	Pulse skipping		0		
Maximum Duty Cycle	CTRL = V <sub>V+</sub> , CS = GND	91	94		%

# High-Efficiency, 26V Step-Up Converter for White LED Main and Subdisplay Backlighting

MAX1582

## ELECTRICAL CHARACTERISTICS (continued)

( $V_{V+} = +3.0V$ ,  $V_{OUT1} = 20V$ ,  $L1 = 22\mu H$ ,  $C_{OUT} = 0.1\mu F$ ,  $C_{COMP} = 0.022\mu F$ ,  $R_{SENSE} = 7.5\Omega$ ,  $V_{CTRL} = +1.5V$ ,  $EN1 = EN2 = V+$ ,  $T_A = 0^\circ C$  to  $+85^\circ C$ , unless otherwise noted. Typical values are at  $T_A = +25^\circ C$ .) (Note 1)

PARAMETER	CONDITIONS	MIN	TYP	MAX	UNITS
<b>N-CHANNEL SWITCH</b>					
LX On-Resistance			1.50	2.25	$\Omega$
LX Leakage Current	$V_{LX} = +28V$	$T_A = +25^\circ C$	0.01	5	$\mu A$
		$T_A = +85^\circ C$	0.02		
LX Current Limit	Duty cycle = 90%	450	650	950	mA
<b>MAIN AND SUBDISPLAY ON/OFF SWITCHES</b>					
OUT1 to OUT2 On-Resistance	$EN1 = GND$ , $EN2 = V+$		2.5		$\Omega$
OUT2 to CS On-Resistance	$EN1 = V+$ , $EN2 = GND$		2.5		$\Omega$
OUT1 to OUT2 Leakage Current	$EN1 = EN2 = V+$ , $V_{OUT1} = 25V$ , $V_{OUT2} = +9V$ , $T_A = +85^\circ C$		0.05		$\mu A$
OUT2 to CS Leakage Current	$EN1 = EN2 = V+$ , $V_{OUT2} = 12V$ , $V_{CS} = 0$ , $T_A = +85^\circ C$		0.05		$\mu A$
EN1 and EN2 Logic Input Voltage High	$+2.6V < V_{V+} < +5.5V$	1.6			V
EN1 and EN2 Logic Input Voltage Low	$+2.6V < V_{V+} < +5.5V$			0.6	V
EN1 and EN2 Input Leakage	$V_{V+} = V_{EN1} = V_{EN2} = +5.5V$	$T_A = +25^\circ C$	0.02	1	$\mu A$
		$T_A = +85^\circ C$	0.1		

## ELECTRICAL CHARACTERISTICS

( $V_{V+} = +3.0V$ ,  $V_{OUT1} = +20V$ ,  $L1 = 22\mu H$ ,  $C_{OUT} = 0.1\mu F$ ,  $C_{COMP} = 0.022\mu F$ ,  $R_{SENSE} = 7.5\Omega$ ,  $V_{CTRL} = +1.5V$ ,  $EN1 = EN2 = V+$ ,  $T_A = -40^\circ C$  to  $+85^\circ C$ , unless otherwise noted.) (Notes 1, 3)

PARAMETER	CONDITIONS	MIN	MAX	UNITS
Supply Voltage		2.6	5.5	V
Undervoltage Lockout (UVLO) Threshold	$V+$ rising or falling	2.10	2.55	V
Quiescent Current	No switching, $V_C = +0.25V$		0.56	mA
Overshoot Lockout (OVLO) Threshold	Rising	26	29	V
OUT1 Input Bias Current	$V_{OUT1} = +26V$ , $EN1 = EN2 = V+$	20	65	$\mu A$
Output Voltage Range	(Note 2)	( $V_{V+} - V_{DIODE}$ )	25.5	V
<b>ERROR AMPLIFIER</b>				
CTRL to CS Regulation	$V_{CTRL} = +1.0V$ , $V_{V+} = +2.6V$ to $+5.5V$	0.093	0.107	V
CTRL Input Resistance	$0 < V_{CTRL} < +1.0V$	290	780	$k\Omega$
CS to COMP Transconductance	$V_{COMP} = 1.0V$	32	85	$\mu S$
<b>OSCILLATOR</b>				
Operating Frequency		0.75	1.30	MHz

# High-Efficiency, 26V Step-Up Converter for White LED Main and Subdisplay Backlighting

## ELECTRICAL CHARACTERISTICS (continued)

( $V_{V+} = +3.0V$ ,  $V_{OUT1} = +20V$ ,  $L1 = 22\mu H$ ,  $C_{OUT} = 0.1\mu F$ ,  $C_{COMP} = 0.022\mu F$ ,  $R_{SENSE} = 7.5\Omega$ ,  $V_{CTRL} = +1.5V$ ,  $EN1 = EN2 = V+$ ,  $T_A = -40^\circ C$  to  $+85^\circ C$ , unless otherwise noted.) (Notes 1, 3)

PARAMETER	CONDITIONS	MIN	MAX	UNITS
Maximum Duty Cycle	CTRL = V+, CS = GND	91		%
<b>N-CHANNEL SWITCH</b>				
LX On-Resistance			2.25	$\Omega$
LX Current Limit	Duty cycle = 90%	450	950	mA

**Note 1:** Limits are 100% production tested at  $T_A = +25^\circ C$  for UCSP parts. Limits over the entire operating temperature range are guaranteed by design and characterization but are not production tested.

**Note 2:** The minimum output voltage is the input voltage minus the forward voltage drop of the Schottky diode:

$$V_{OUT(MIN)} = V_{V+} - V_{DIODE}$$

**Note 3:** Specifications to  $-40^\circ C$  are guaranteed by design and not production tested.

## Typical Operating Characteristics

(See the *Typical Applications Circuit*,  $V_{V+} = V_{VP} = 3.6V$ ,  $I_{LED} = 15mA$ ,  $L1 = 22\mu H$ ,  $C_{OUT1} = 0.1\mu F$ ,  $C_{COMP} = 0.022\mu F$ ,  $R_{SENSE} = 7.5\Omega$ ,  $V_{CTRL} = 1.5V$ , 4 LEDs,  $T_A = +25^\circ C$ , unless otherwise noted.)

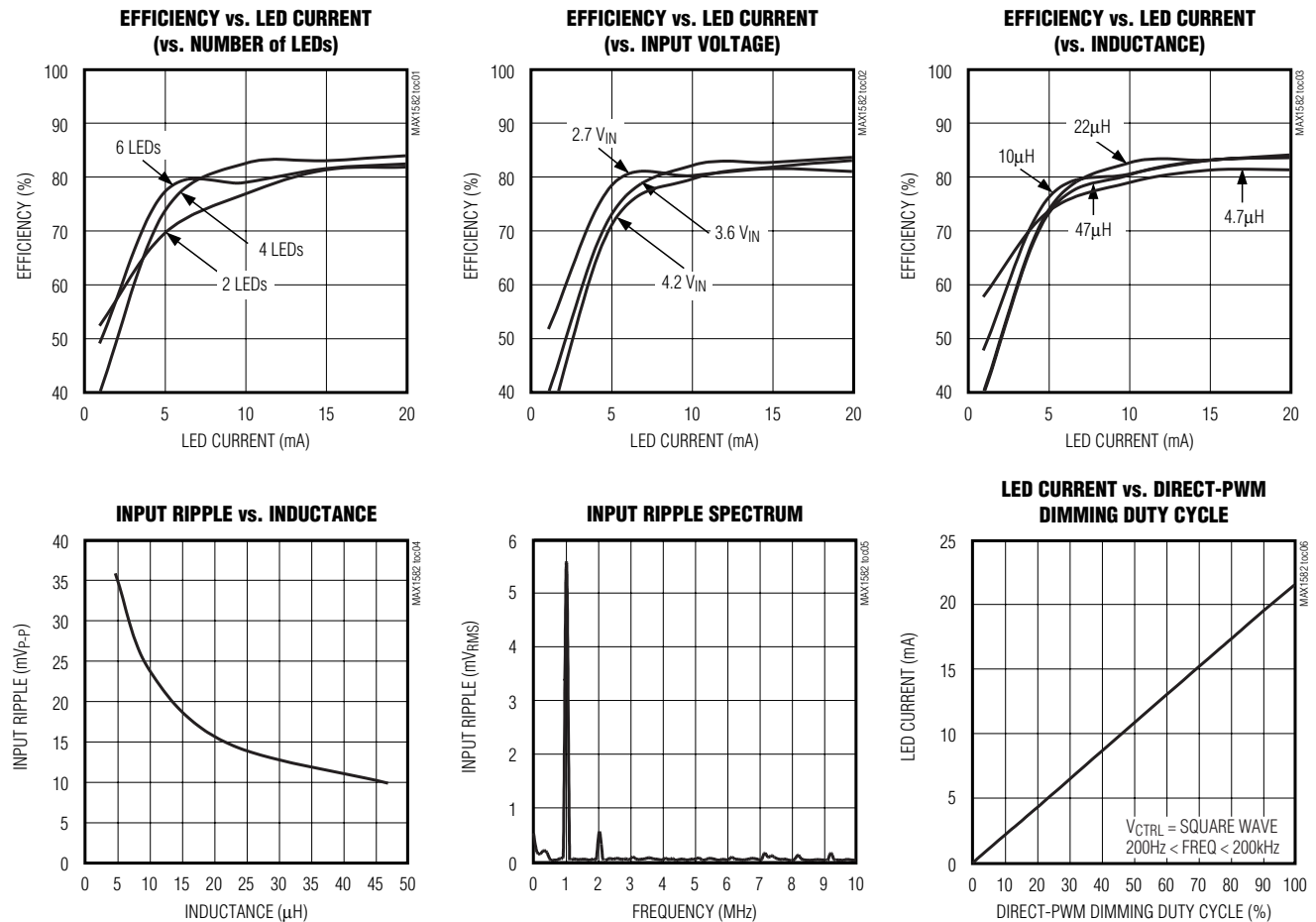

# High-Efficiency, 26V Step-Up Converter for White LED Main and Subdisplay Backlighting

MAX1582

## Typical Operating Characteristics (continued)

(See the *Typical Applications Circuit*,  $V_{V+} = V_{VP} = 3.6V$ ,  $I_{LED} = 15mA$ ,  $L_1 = 22\mu H$ ,  $C_{OUT1} = 0.1\mu F$ ,  $C_{COMP} = 0.022\mu F$ ,  $R_{SENSE} = 7.5\Omega$ ,  $V_{CTRL} = 1.5V$ , 4 LEDs,  $T_A = +25^\circ C$ , unless otherwise noted.)

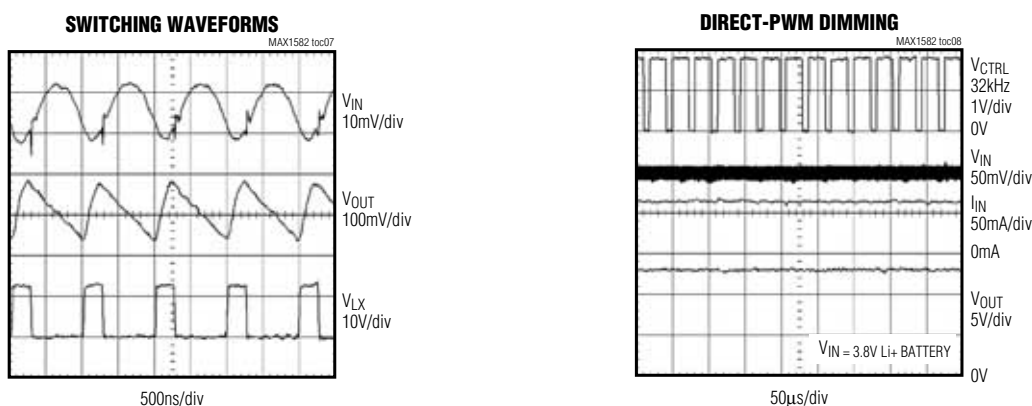

## Pin Description

PIN		NAME	FUNCTION
QFN	UCSP		
1	A1	V+	Input Voltage Supply. Input voltage range is 2.6V to 5.5V. Connect a 2.2 $\mu F$ capacitor from V+ to PGND.
2	A2	VP	High-Current Input Supply. Connect to V+.
3	A3	CTRL	Brightness Control Input. LED brightness is controlled by the voltage applied to CTRL. Varying the voltage from 0 to +1.62V adjusts the brightness from dim to bright, respectively. Any voltage above +1.62V does not increase brightness.
4	A4	COMP	Compensation Input. Connect a 0.022 $\mu F$ capacitor ( $C_{COMP}$ ) from COMP to GND. $C_{COMP}$ stabilizes the converter and controls soft-start. $C_{COMP}$ discharges to GND when in shutdown.
5	B4	GND	Ground. Connect to PGND at a single point near the IC.
6	C4	EN1	Enable 1 Input. Drive EN1 high to enable the main-display LEDs. Pull EN1 low to turn off the main-display LEDs. Pull both EN1 and EN2 low to place the IC in low-current shutdown mode.
7	D4	EN2	Enable 2. Drive EN2 high to enable the subdisplay LEDs. Pull EN2 low to turn off the subdisplay LEDs. Pull both EN1 and EN2 low to place the IC in low-current shutdown mode.
8	D3	CS	Current-Sense Feedback Input. Connect a resistor ( $R_{SENSE}$ ) from CS to GND to set the LED bias current. The voltage at CS regulates to $V_{CTRL} / 10$ or +0.162V, whichever is lower.
9	D2	OUT2	Display Switch Output. OUT2 is internally connected to CS when only the main display is lit. OUT2 is internally connected to OUT1 when only the subdisplay is lit. OUT2 is high impedance when both displays are lit and when the IC is shut down.
10	D1	OUT1	Overvoltage Sense. When $V_{OUT1}$ is greater than 27V, the internal N-channel MOSFET turns off until $V_{OUT1}$ drops below 25V, then the IC reenters soft-start. Connect a 0.1 $\mu F$ capacitor from OUT1 to PGND.
11	C1	LX	Inductor Connection. During shutdown, this pin is high impedance.
12	B1	PGND	Power Ground. Connect to GND at a single point near the IC.
EP	—	EP	Exposed Paddle. Connect directly to GND and PGND under the IC.

# High-Efficiency, 26V Step-Up Converter for White LED Main and Subdisplay Backlighting

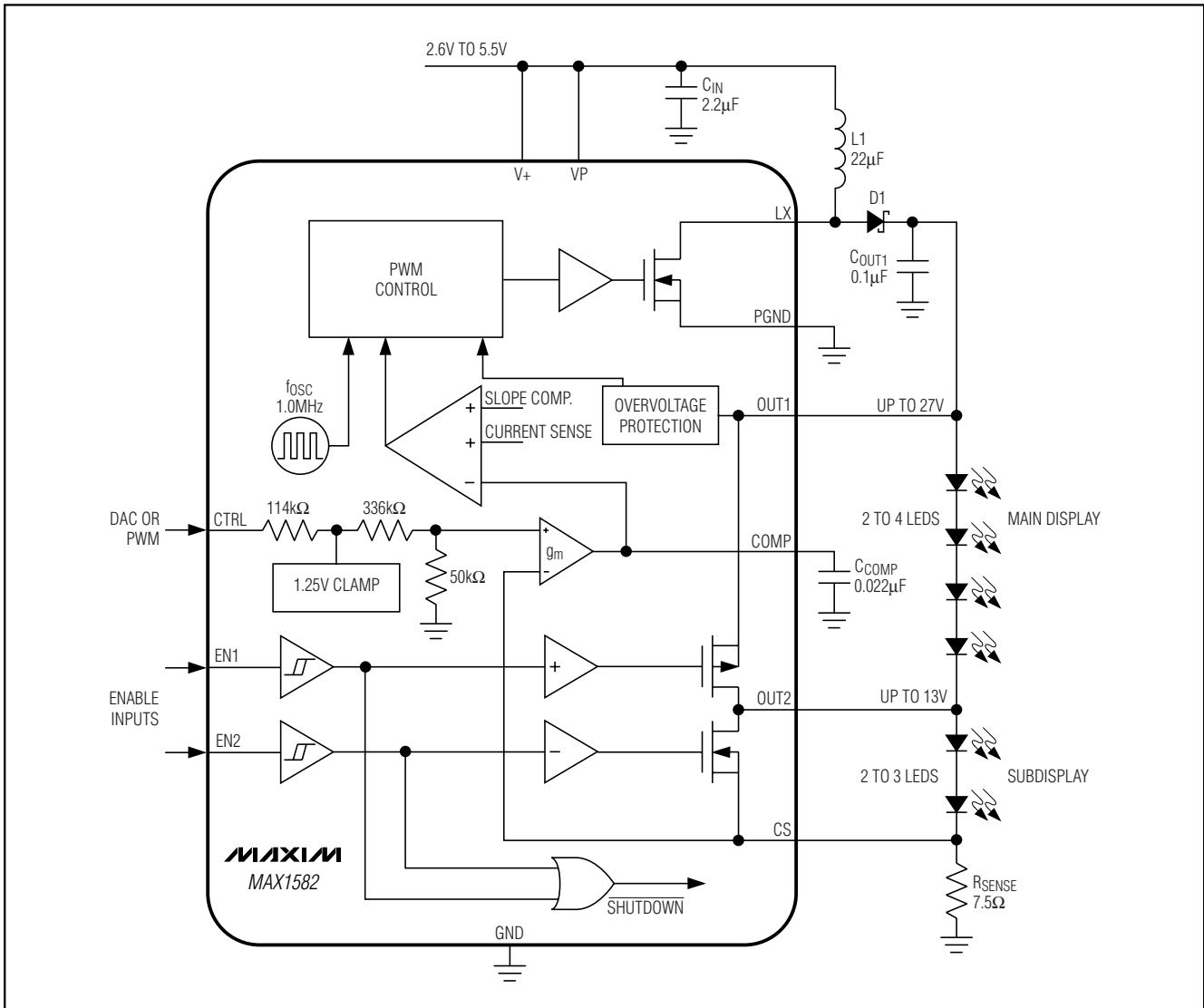

Figure 1. Functional Diagram

## Detailed Description

The MAX1582's high efficiency and small size make it ideally suited to drive up to six series-connected LEDs. Separate enable inputs are provided to control the main and subdisplay backlighting. The MAX1582 operates as a boost DC-to-DC converter that regulates output current rather than voltage. It provides even illumination by sourcing the same output current through each LED, eliminating the need for expensive factory calibration. The fast 1MHz internal oscillator allows for a small inductor and small input and output capacitors while minimizing input and output ripple.

## Shutdown for Main and Subdisplay

The MAX1582 has two enable inputs (EN1 and EN2) used to enable or shutdown the main and subdisplay LEDs. When EN1 and EN2 are both high, all LEDs are lit. With EN1 high and EN2 low, the main-display LEDs are lit, and the subdisplay LEDs are shorted by the MAX1582. With EN1 low and EN2 high, the main-display LEDs are shorted and the subdisplay LEDs are lit.

When both EN1 and EN2 are low, the MAX1582 enters shutdown, reducing supply current to 0.01µA (typ). Although the internal N-channel MOSFET does not switch in shutdown, there is still a DC-current path

# High-Efficiency, 26V Step-Up Converter for White LED Main and Subdisplay Backlighting

between the input and the LEDs through the inductor and Schottky diode. To ensure the LEDs remain off when the MAX1582 is in shutdown, the minimum input forward voltage of the LED array must exceed the maximum input voltage. Typically, the leakage current through the LEDs in shutdown is less than 1 $\mu$ A.

## Soft-Start

The MAX1582 attains soft-start by charging C<sub>COMP</sub> gradually with a current source. When V<sub>COMP</sub> rises above 1.25V, the internal MOSFET begins switching, but at a reduced duty cycle. When V<sub>COMP</sub> rises above 2.25V, the duty cycle is at its maximum.

## Overvoltage Protection

OVLO occurs when V<sub>OUT1</sub> rises above 27V. The protection circuitry stops the internal MOSFET from switching and causes V<sub>COMP</sub> to decay to GND. The device comes out of OVLO and into soft-start when V<sub>OUT1</sub> falls below 25V.

## Design Procedure

### Adjusting LED Current

Adjusting the MAX1582's output current changes the brightness of the LEDs. The LED current is set by the voltage at CTRL (V<sub>CTRL</sub>) and the sense-resistor value (R<sub>SENSE</sub>):

$$I_{LED} = \frac{V_{CTRL}}{10 \times R_{SENSE}}$$

The V<sub>CTRL</sub> voltage range for adjusting output current is 0 to +1.62V. To set the maximum current, calculate R<sub>SENSE</sub> when V<sub>CTRL</sub> is at its maximum as follows:

$$R_{SENSE} = \frac{1.62}{10 \times I_{LED(MAX)}}$$

Power dissipation in R<sub>SENSE</sub> is typically less than 5mW; therefore, a standard chip resistor is sufficient.

### PWM Dimming Control

CTRL is also used as a digital input, allowing LED brightness control with a logic-level PWM signal applied directly to CTRL. The frequency range is from 200Hz to 200kHz, while 0% duty cycle corresponds to zero current and 100% duty cycle corresponds to full current. The error amplifier and compensation capacitor form a lowpass filter, so PWM dimming results in DC current to the LEDs without any additional RC filters required.

## Capacitor Selection

The exact values of input and output capacitors are not critical. The typical value for the input capacitor is 2.2 $\mu$ F, and the typical value for the output capacitor is 0.1 $\mu$ F. Larger value capacitors can be used to reduce input and output ripple, but at the expense of size and higher cost.

C<sub>COMP</sub> stabilizes the converter and controls soft-start. Connect a 0.022 $\mu$ F capacitor from COMP to GND. The minimum value for C<sub>COMP</sub> is C<sub>OUT</sub> / 10. The soft-start time is found from:

$$t_{SS} = C_{COMP} \times \left( \frac{1.25V}{5\mu A} \right)$$

## Inductor Selection

Recommended inductor values range from 10 $\mu$ H to 47 $\mu$ H. A 22 $\mu$ H inductor optimizes the efficiency for most applications, while maintaining a low 15mV<sub>p-p</sub> input ripple. With input voltages near 5V, a larger value of inductance may be more efficient. To prevent core saturation, ensure that the inductor saturation current rating exceeds the peak inductor current for the application. Calculate the peak inductor current with the following formula:

$$I_{PEAK} \cong \frac{V_{OUT1(MAX)} \times I_{LED(MAX)}}{0.8 \times V_{IN(MIN)}} + \frac{V_{IN(MIN)} \times 0.8\mu s}{2 \times L}$$

## Schottky Diode Selection

The MAX1582's high switching frequency demands a high-speed rectification diode (D1) for optimum efficiency. A Schottky diode is recommended due to its fast recovery time and low forward-voltage drop. Ensure that the diode's average and peak current rating exceeds the average output current and peak inductor current. In addition, the diode's reverse breakdown voltage must exceed V<sub>OUT1</sub>. The RMS diode current can be calculated from:

$$I_{DIODE(RMS)} \cong \sqrt{I_{OUT1} \times I_{PEAK}}$$

## Applications Information

### PC Board Layout

Due to fast-switching waveforms and high-current paths, careful PC board layout is required. An evaluation kit (MAX1582EVKIT) is available to speed design.

## High-Efficiency, 26V Step-Up Converter for White LED Main and Subdisplay Backlighting

When laying out a board, minimize trace lengths between the IC and R<sub>SENSE</sub>, the inductor, the diode, the input capacitor, and the output capacitor. Keep traces short, direct, and wide. Keep noisy traces, such as the LX node trace, away from CS. The input bypass capacitor (C<sub>IN</sub>) should be placed as close to the IC as possible. For the thin QFN package, PGND and GND should be connected directly to the exposed paddle underneath the IC. The ground connections of C<sub>IN</sub> and C<sub>OUT1</sub> should be as close together as possible. The traces from IN to the inductor and from the Schottky diode to the LEDs can be longer.

### Chip Information

TRANSISTOR COUNT: 2546

PROCESS: BiCMOS

### Pin Configurations (continued)

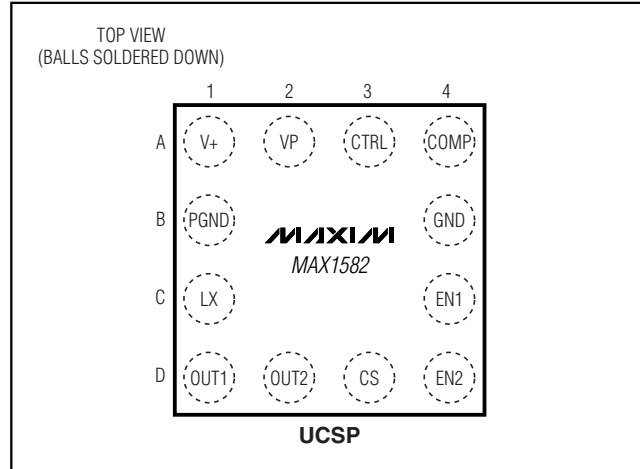

# High-Efficiency, 26V Step-Up Converter for White LED Main and Subdisplay Backlighting

## Package Information

(The package drawing(s) in this data sheet may not reflect the most current specifications. For the latest package outline information, go to [www.maxim-ic.com/packages](http://www.maxim-ic.com/packages).)

MAX1582

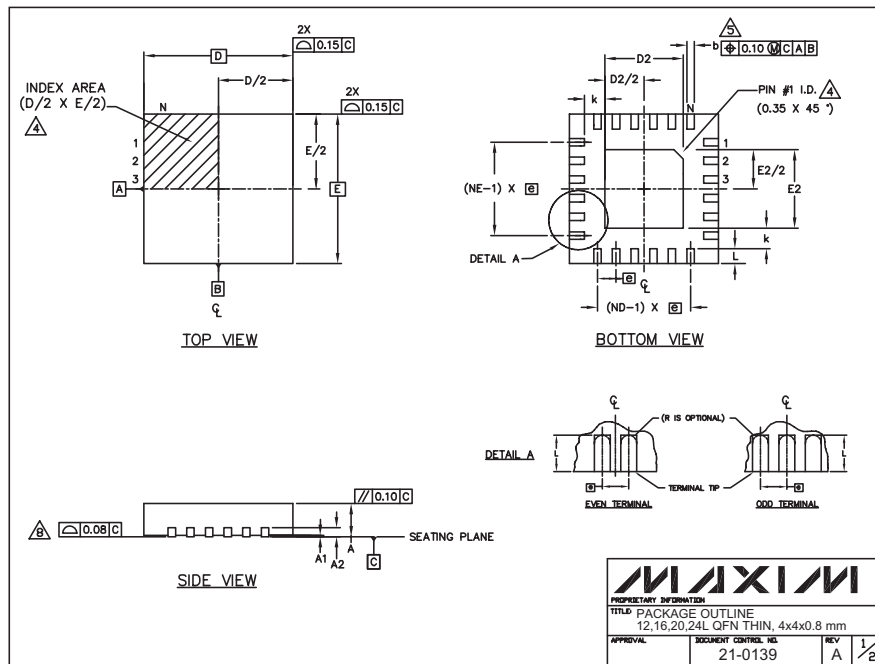

24L QFN THINLEPS

COMMON DIMENSIONS												
PKG REF.	12L 4x4			16L 4x4			20L 4x4			24L 4x4		
	MIN.	NDM.	MAX.	MIN.	NDM.	MAX.	MIN.	NDM.	MAX.	MIN.	NDM.	MAX.
A	0.70	0.75	0.80	0.70	0.75	0.80	0.70	0.75	0.80	0.70	0.75	0.80
A1	0.0	0.02	0.05	0.0	0.02	0.05	0.0	0.02	0.05	0.0	0.02	0.05
A2	0.20 REF			0.20 REF			0.20 REF			0.20 REF		
b	0.25	0.30	0.35	0.25	0.30	0.35	0.20	0.25	0.30	0.18	0.23	0.30
D	3.90	4.00	4.10	3.90	4.00	4.10	3.90	4.00	4.10	3.90	4.00	4.10
E	3.90	4.00	4.10	3.90	4.00	4.10	3.90	4.00	4.10	3.90	4.00	4.10
e	0.80 BSC.			0.65 BSC.			0.50 BSC.			0.50 BSC.		
k	0.25	-	-	0.25	-	-	0.25	-	-	0.25	-	-
L	0.45	0.55	0.65	0.45	0.55	0.65	0.45	0.55	0.65	0.30	0.40	0.50
N	12			16			20			24		
ND	3			4			5			6		
NE	3			4			5			6		
JEDEC Var.	WGGB			WGGC			WGGD-1			WGGD-2		

EXPOSED PAD VARIATIONS						
PKG CODES	D2			E2		
	MIN.	NDM.	MAX.	MIN.	NDM.	MAX.
T1244-2	1.95	2.10	2.25	1.95	2.10	2.25
T1644-2	1.95	2.10	2.25	1.95	2.10	2.25
T2044-1	1.95	2.10	2.25	1.95	2.10	2.25
T2444-1	2.45	2.60	2.63	2.45	2.60	2.63

NOTES:

- DIMENSIONING & TOLERANCING CONFORM TO ASME Y14.5M-1994.
- ALL DIMENSIONS ARE IN MILLIMETERS. ANGLES ARE IN DEGREES.
- N IS THE TOTAL NUMBER OF TERMINALS.
- THE TERMINAL #1 IDENTIFIER AND TERMINAL NUMBERING CONVENTION SHALL CONFORM TO JEDEC 95-1 SPP-012. DETAILS OF TERMINAL #1 IDENTIFIER ARE OPTIONAL, BUT MUST BE LOCATED WITHIN THE ZONE INDICATED. THE TERMINAL #1 IDENTIFIER MAY BE EITHER A MOLD OR MARKED FEATURE.
- DIMENSION b APPLIES TO METALLIZED TERMINAL AND IS MEASURED BETWEEN 0.25 mm AND 0.30 mm FROM TERMINAL TIP.
- ND AND NE REFER TO THE NUMBER OF TERMINALS ON EACH D AND E SIDE RESPECTIVELY.
- DEPOPULATION IS POSSIBLE IN A SYMMETRICAL FASHION.
- COPLANARITY APPLIES TO THE EXPOSED HEAT SINK SLUG AS WELL AS THE TERMINALS.
- DRAWING CONFORMS TO JEDEC MO220.

# High-Efficiency, 26V Step-Up Converter for White LED Main and Subdisplay Backlighting

## Package Information (continued)

(The package drawing(s) in this data sheet may not reflect the most current specifications. For the latest package outline information, go to [www.maxim-ic.com/packages](http://www.maxim-ic.com/packages).)

16LUCSP:EPS

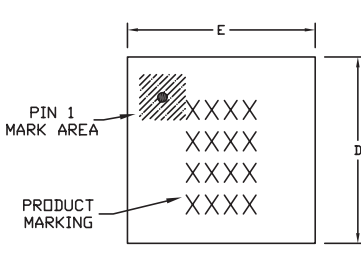

**TOP VIEW**

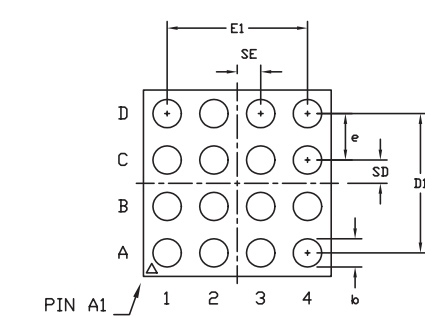

**BOTTOM VIEW**

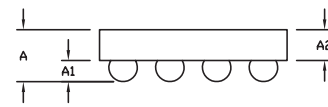

**SIDE VIEW**

COMMON DIMENSIONS	
A	0.60±0.05
A1	0.27±0.03
A2	0.33 REF.
b	∅0.37 BASIC
D1	1.50 BASIC
E1	1.50 BASIC
e	0.50 BASIC
SD	0.25 BASIC
SE	0.25 BASIC

PKG. CODE	VARIABLE DIMENSIONS		DEPOPULATED SOLDER BALLS
	D	E	
B16-1	2.02±0.05	2.02±0.05	NONE
B16-2	2.02±0.05	2.02±0.05	B3, C3
B16-3	2.02±0.05	2.02±0.05	B3, C2
B16-4	2.02±0.05	2.02±0.05	B2, C3

**NOTES:**  
 1. ALL DIMENSIONS ARE IN MILLIMETERS.  
 2. PRODUCT MARKING: NUMBER OF CHARACTERS AND LINES VARY PER PRODUCT.

MAXIM

PROPRIETARY INFORMATION

TITLE:  
PACKAGE OUTLINE, 4x4 UCSP

APPROVAL	DOCUMENT CONTROL NO. 21-0101	REV. F	1/1
----------	---------------------------------	-----------	-----

Maxim cannot assume responsibility for use of any circuitry other than circuitry entirely embodied in a Maxim product. No circuit patent licenses are implied. Maxim reserves the right to change the circuitry and specifications without notice at any time.

10 \_\_\_\_\_ **Maxim Integrated Products, 120 San Gabriel Drive, Sunnyvale, CA 94086 408-737-7600**

Copyright © Each Manufacturing Company.

All Datasheets cannot be modified without permission.

This datasheet has been download from :

[www.AllDataSheet.com](http://www.AllDataSheet.com)

100% Free DataSheet Search Site.

Free Download.

No Register.

Fast Search System.

[www.AllDataSheet.com](http://www.AllDataSheet.com)