

MAXIM

SOT23 Vibrator Motor Driver

MAX1749

General Description

The MAX1749 allows for a constant vibration force while operating from a +2.5V to +6.5V input range and delivering up to 120mA. A PMOS pass transistor allows the 80µA supply current to remain independent of the load.

The output voltage can be adjusted from +1.25V to V_{IN} with an external resistor-divider. When turned off (ON = low), the MAX1749 supply current drops to 1µA (max) to minimize battery drain. Other features include short-circuit protection, thermal shutdown protection, and reverse battery protection. The MAX1749 is available in a 5-pin SOT23 package.

Features

- ◆ Fixed 1.25V or Adjustable (1.25V to 6.5V) Output
- ◆ Low Cost
- ◆ Thermal Overload Protection
- ◆ Output Current Limit
- ◆ Reverse Battery Protection
- ◆ Low 0.1nA Off Supply Current
- ◆ Low 80µA Full-Load Supply Current

Applications

Wireless Handset Vibrator Motor Drivers
 Pager Vibrator Motor Drivers

Ordering Information

PART	TEMP. RANGE	PIN-PACKAGE	TOP MARK
MAX1749EUK-T	-40°C to +85°C	5 SOT23	ADIX

Typical Operating Circuit

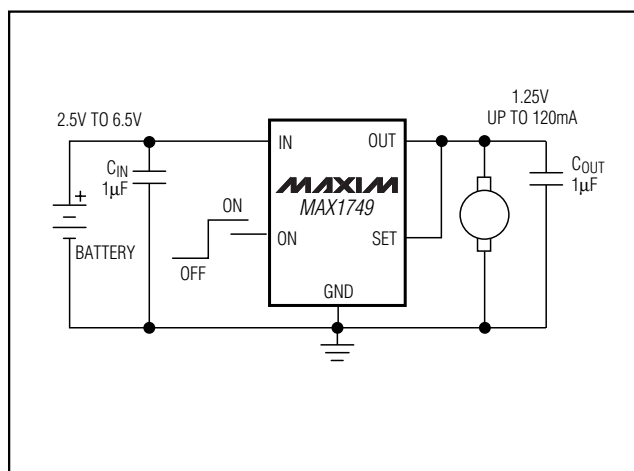

Pin Configuration

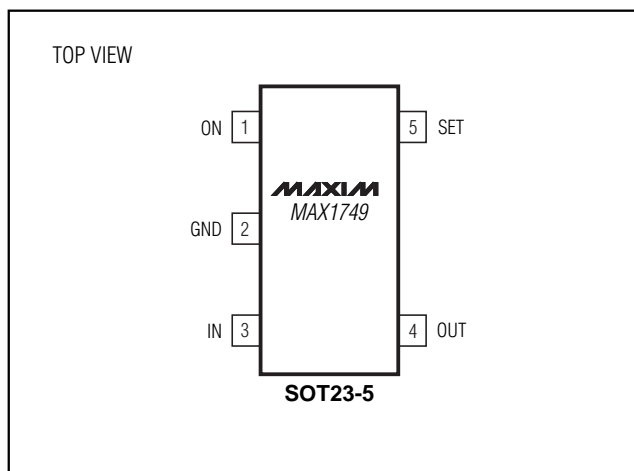

SOT23 Vibrator Motor Driver

ABSOLUTE MAXIMUM RATINGS

IN to GND	-7V to +7V	Operating Temperature Range	-40°C to +85°C
Output Short-Circuit Duration	Infinite	Junction Temperature	+150°C
SET to GND	-0.3V to +7V	θ_{JA}	+140°C/W
ON to GND	-7V to +7V	Storage Temperature Range	-65°C to +150°C
ON to IN	-7V to +0.3V	Lead Temperature (soldering, 10sec)	+300°C
OUT to GND	-0.3V to (V _{IN} + 0.3V)		
Continuous Power Dissipation (T _A = +70°C)			
SOT23-5 (derate 7.1mW/°C above +70°C)	571mW		

Stresses beyond those listed under "Absolute Maximum Ratings" may cause permanent damage to the device. These are stress ratings only, and functional operation of the device at these or any other conditions beyond those indicated in the operational sections of the specifications is not implied. Exposure to absolute maximum rating conditions for extended periods may affect device reliability.

ELECTRICAL CHARACTERISTICS

(V_{IN} = +3.6V, T_A = -40°C to +85°C, unless otherwise noted. Typical values are at T_A = +25°C.) (Note 1)

PARAMETER	SYMBOL	CONDITIONS	MIN	TYP	MAX	UNITS
Input Voltage	V _{IN}		2.5		6.5	V
Output Voltage	V _{OUT}	0.1mA ≤ I _{OUT} ≤ 50mA, SET = OUT	1.13	1.25	1.37	V
Maximum Output Current			120			mA
Current Limit (Note 2)	I _{LIM}			280		mA
Ground Pin Current	I _Q			80	200	μA
Off Supply Current	I _{OFF}	V _{OUT} = V _{ON} = GND	T _A = +25°C	0.0001	1	μA
			T _A = +85°C	0.02		
ON INPUT						
ON Input High Threshold	V _{IH}		2.0			V
ON Input Low Threshold	V _{IL}				0.4	V
ON Input Bias Current	I _{ON}	ON = IN	T _A = +25°C	0	100	nA
			T _A = +85°C	0.05		
SET INPUT						
SET Input Leakage Current	I _{SET}	V _{SET} = 1.4V	T _A = +25°C	0.03	10	nA
			T _A = +85°C	0.5		
THERMAL PROTECTION						
Thermal Shutdown Temperature	T _{SHDN}			170		°C
Thermal Shutdown Hysteresis	ΔT _{SHDN}			20		°C

Note 1: Limits are 100% production tested at T_A = +25°C. Limits over the operating temperature range are guaranteed through correlation using Statistical Quality Control (SQC) methods.

Note 2: Not tested. For design purposes, the current limit should be considered 120mA minimum to 420mA maximum.

SOT23 Vibrator Motor Driver

MAX1749

Typical Operating Characteristics

($V_{IN} = +3.6V$, SET = OUT, $C_{IN} = 1\mu F$, $C_{OUT} = 1\mu F$, $T_A = +25^\circ C$, unless otherwise noted.)

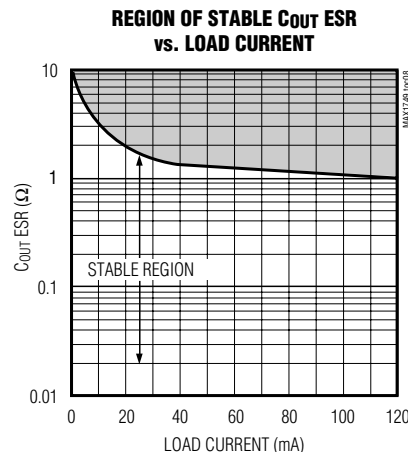
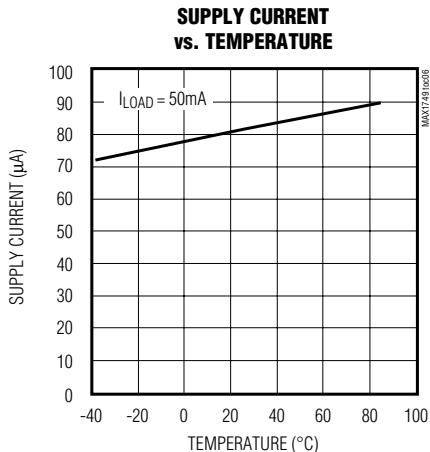
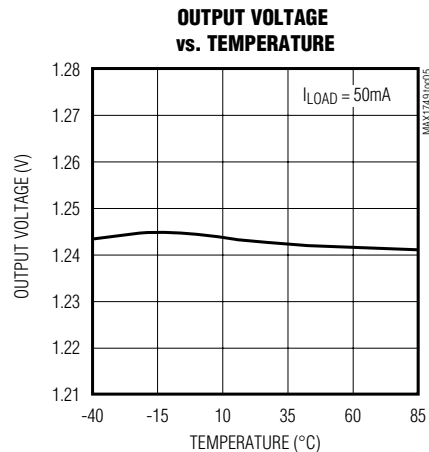
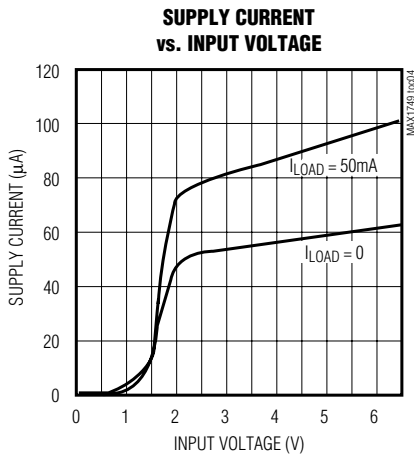
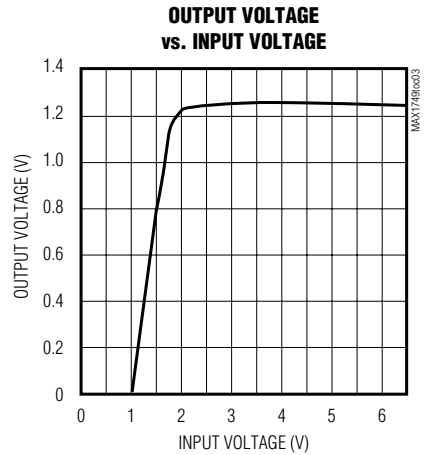
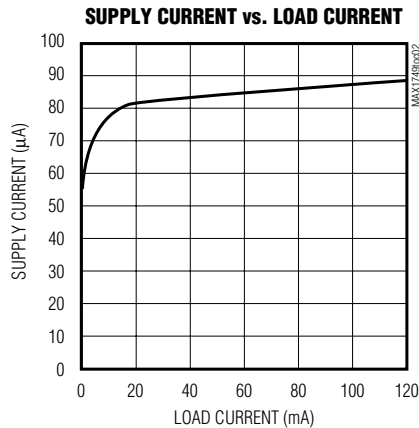
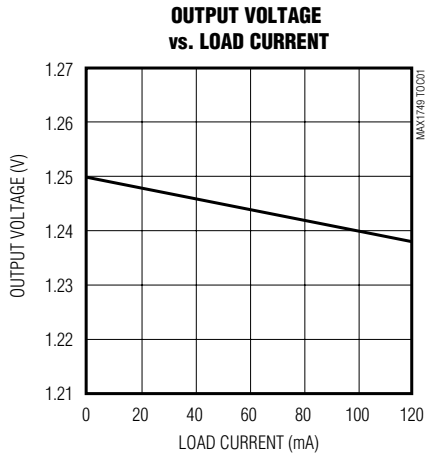

SOT23 Vibrator Motor Driver

Typical Operating Characteristics (continued)

($V_{IN} = +3.6V$, SET = OUT, $C_{IN} = 1\mu F$, $C_{OUT} = 1\mu F$, $T_A = +25^\circ C$, unless otherwise noted.)

LINE-TRANSIENT RESPONSE

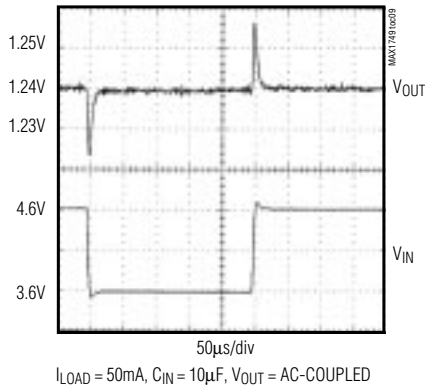

LOAD-TRANSIENT RESPONSE

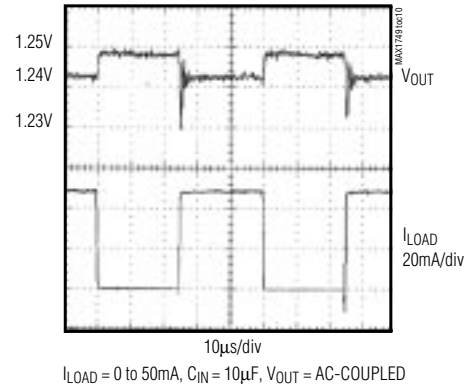

ON/OFF WAVEFORM ($V_{IN} = 5.0V$)

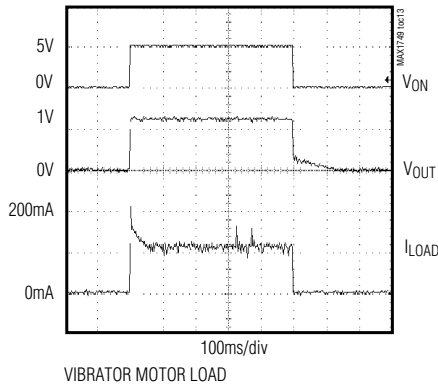

ON/OFF WAVEFORM ($V_{IN} = 3.6V$)

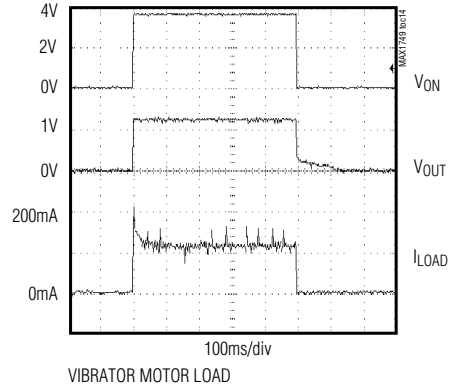

SOT23 Vibrator Motor Driver

MAX1749

Pin Description

PIN	NAME	FUNCTION
1	ON	Active-High On/Off Input. Apply a logic high to deliver power to the load. Apply a logic low to disconnect the load and reduce the supply current to 0.1nA.
2	GND	Ground. This pin also functions as a heatsink. Solder to large pads or the circuit board ground plane to maximize thermal dissipation.
3	IN	Regulator Input. Supply voltage can range from +2.5V to +6.5V. Bypass with 1 μ F to GND (see <i>Capacitor Selection and Regulator Stability</i>).
4	OUT	Regulator Output. Fixed 1.25V or adjustable from 1.25V to V_{IN} . Sources up to 120mA. Bypass with a 1 μ F, <0.2 Ω typical ESR capacitor to GND.
5	SET	Feedback Input for Setting the Output Voltage. Connect to OUT for 1.25V regulated output (see <i>Output Voltage Selection</i>). Connect to an external resistor-divider for adjustable-output operation.

Detailed Description

The MAX1749 is a low-quiescent-current, vibrator motor driver designed for battery-powered wireless handsets and pagers. The device supplies an adjustable +1.25V to +6.5V output for load currents up to 120mA. The MAX1749 allows for a constant vibration force while operating from a +2.5V to +6.5V input voltage range.

The 1.25V bandgap reference is connected to the error amplifier's inverting input. The error amplifier compares this reference with the feedback voltage and amplifies the difference. The MOSFET driver reads the error signal and applies the appropriate drive to the p-channel pass transistor. If the feedback voltage is lower than the reference voltage, the pass-transistor gate is pulled lower than the

reference, allowing more current to flow and increasing the output voltage. If the feedback voltage is too high, the pass-transistor gate is pulled-up, allowing less current to flow to the output. The output voltage is fed back to SET either directly for a 1.25V fixed output or through an external resistor-divider for an adjustable +1.25V to V_{IN} output. Additional blocks include a current limiter, reverse battery protection, a thermal sensor, and ON/OFF logic.

Internal P-Channel Pass Transistor

The MAX1749 features a 1.1 Ω typical P-channel MOSFET pass transistor. This provides several advantages over similar designs using PNP pass transistors, including longer battery life.

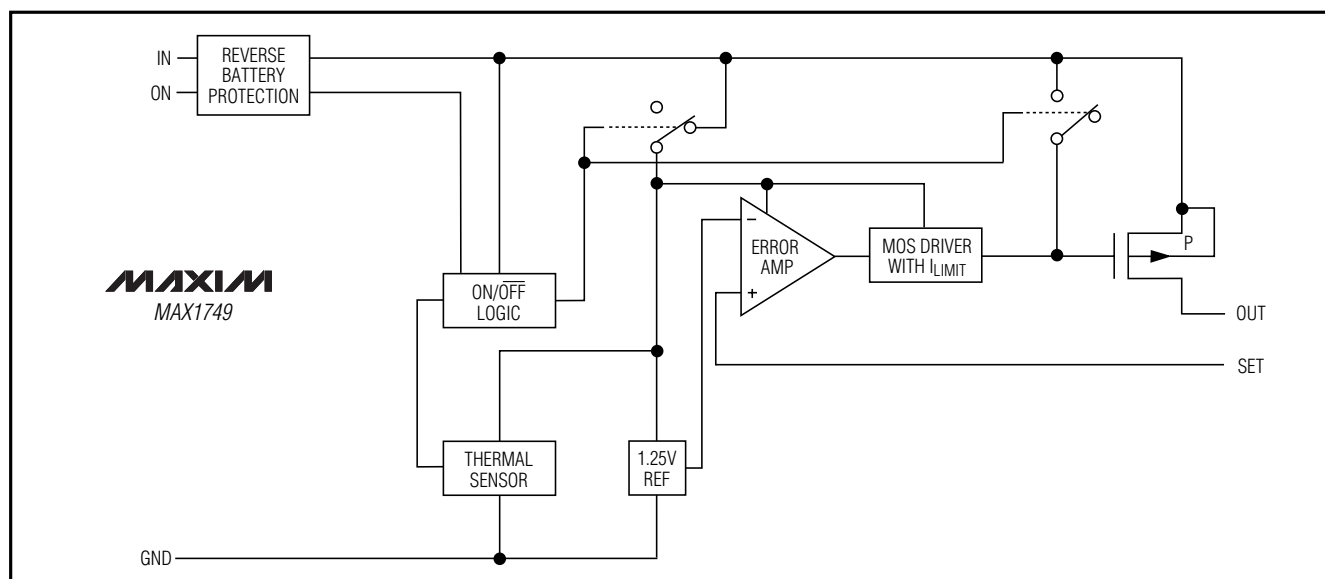

Figure 1. Functional Diagram

SOT23 Vibrator Motor Driver

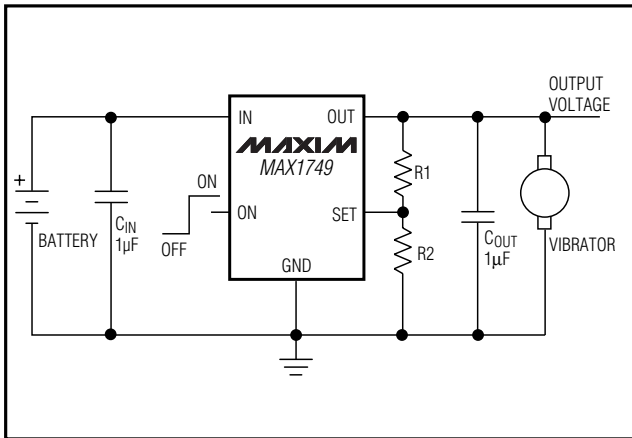

Figure 2. Adjustable Output Using External Feedback Resistors

The P-channel MOSFET requires no base drive current, which reduces quiescent current considerably. PNP-based regulators waste considerable amounts of base current under large loads. The MAX1749 does not suffer from these problems and consumes only 80µA of quiescent current independent of the load (see *Typical Operating Characteristics*).

Output Voltage Selection

To select the preset 1.25V output, connect OUT directly to SET. To adjust the output (1.25V to 6.5V), use two external resistors connected as a voltage divider to SET (Figure 2). The output voltage is set by the following equation:

$$V_{OUT} = V_{SET} (1 + R1 / R2)$$

where $V_{SET} = 1.25V$. To simplify resistor selection:

$$R1 = R2 \left(\frac{V_{OUT}}{V_{SET}} - 1 \right)$$

Choose $R2 = 100k\Omega$ to optimize power consumption, accuracy, and high-frequency power-supply rejection. The total current through the external resistive feedback and load should not be less than 10µA.

ON/OFF

Drive ON high to provide power to the load. Drive ON low to disable power to the load and reduce the supply current to typically 0.1nA (1µA max). Refer to the ON/OFF waveforms in the *Typical Operating Characteristics*. When ON goes high, output current rises to the current limit until V_{OUT} reaches regulation. While in regulation, the output current drops to a lower value sufficient to maintain motor speed. When ON goes low,

the regulator turns off; however, inertial energy in the motor exhibits a slow output voltage decline. The MAX1749 is designed to withstand this condition with no negative effects.

Current Limit

The MAX1749 includes a current limiter that monitors and controls the pass transistor's gate voltage, estimating the output current and limiting it to about 280mA. For design purposes, the current limit should be considered 120mA (min) to 420mA (max). The output can be shorted to ground for an infinite time period without damaging the part.

Thermal-Overload Protection

Thermal-overload protection limits total power dissipation in the MAX1749. When the junction temperature exceeds $T_J = +170^\circ C$, the thermal sensor sends a signal to the ON/OFF logic, turning off the pass transistor and allowing the IC to cool. The thermal sensor will turn the pass transistor on again after the IC's junction temperature cools by typically 20°C, resulting in a pulsed output during continuous thermal-overload conditions.

Operating Region and Power Dissipation

Maximum power dissipation of the MAX1749 depends on the thermal resistance of the case and circuit board, the temperature difference between the die junction and ambient air, and the rate of air flow. The power dissipation across the device is $P = I_{OUT} (V_{IN} - V_{OUT})$. The resulting maximum power dissipation is:

$$P_{MAX} = (T_J - T_A) / \theta_{JA}$$

where $(T_J - T_A)$ is the temperature difference between the MAX1749 die junction and the surrounding air, and θ_{JA} is +140°C/W.

GND performs the dual function of providing an electrical connection to ground and channeling heat away. Connect GND to a large pad or ground plane.

Reverse Battery Protection

The MAX1749 has a unique protection scheme that limits the reverse supply current to less than 1mA when either V_{IN} or V_{ON} falls below ground. The circuitry monitors the polarity of these two pins, disconnecting the internal circuitry and parasitic diodes when the battery is reversed. This feature prevents the device from overheating and damaging the battery.

$V_{IN} > 5.5V$ Minimum Load Current

When operating the MAX1749 with an input voltage above 5.5V, the minimum current through the external feedback resistors and load must be 30µA.

SOT23 Vibrator Motor Driver

MAX1749

Capacitor Selection and Regulator Stability

Use a 1 μ F capacitor on the input and a 1 μ F capacitor on the output of the MAX1749. A higher-value input capacitor (10 μ F) may be necessary if large, fast transients are anticipated and the device is located several inches from the power source. Improve load-transient response and stability by using larger output capacitors. For stable operation over the full temperature range with load currents up to 120mA, use a 1 μ F min capacitor (ESR < 0.2 Ω).

Chip Information

TRANSISTOR COUNT: 148

Package Information

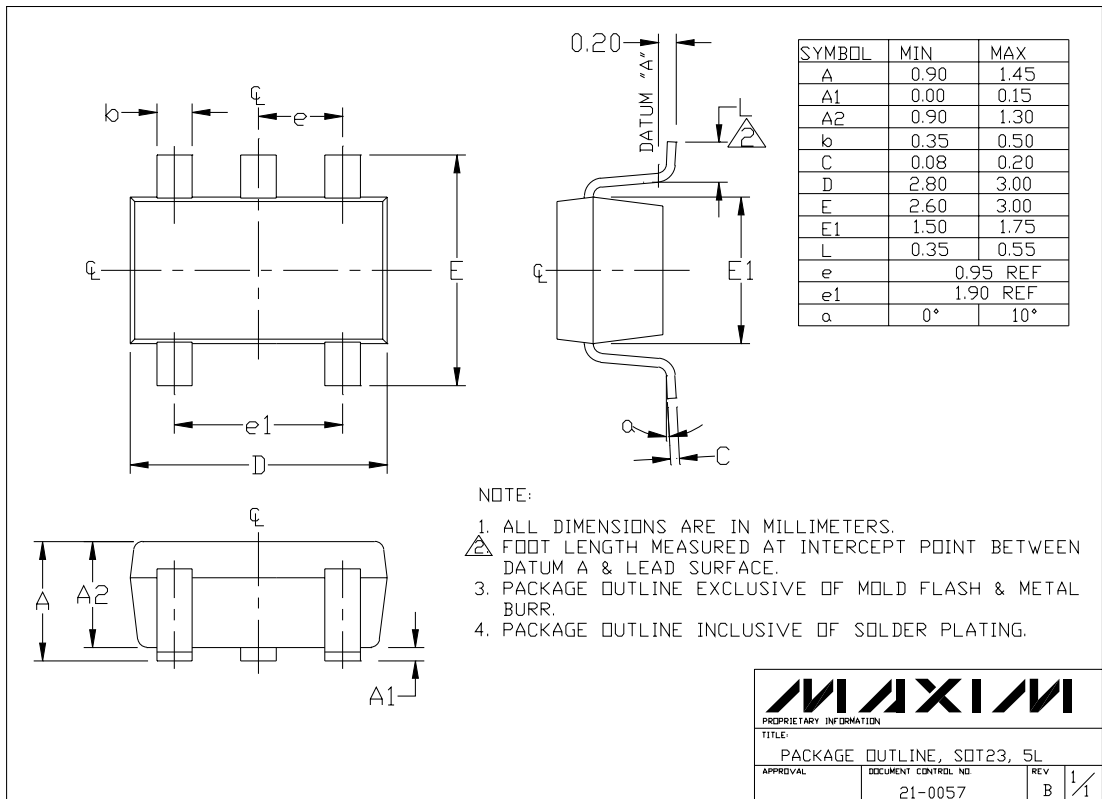

SOT23LEP5

SOT23 Vibrator Motor Driver

NOTES

Maxim cannot assume responsibility for use of any circuitry other than circuitry entirely embodied in a Maxim product. No circuit patent licenses are implied. Maxim reserves the right to change the circuitry and specifications without notice at any time.

8 _____ **Maxim Integrated Products, 120 San Gabriel Drive, Sunnyvale, CA 94086 408-737-7600**

Copyright © Each Manufacturing Company.

All Datasheets cannot be modified without permission.

This datasheet has been download from :

www.AllDataSheet.com

100% Free DataSheet Search Site.

Free Download.

No Register.

Fast Search System.

www.AllDataSheet.com