



# Direct-Conversion Tuner ICs for Digital DBS Applications

## General Description

The MAX2102/MAX2105<sup>†</sup> are low-cost direct-conversion tuner ICs designed for use in digital direct-broadcast satellite (DBS) television set-top box units. The direct-conversion architecture reduces system cost compared to devices with IF-based architectures.

The MAX2102/MAX2105 directly tune L-band signals to baseband using a broadband I/Q downconverter. Operating frequency range spans from at least 950MHz to 2150MHz.

The ICs include a low-noise amplifier (LNA) with automatic gain control (AGC), two downconverter mixers, an oscillator buffer with 90° quadrature generator and prescaler, and baseband amplifiers.

The MAX2102 features an AGC range of 50dB, allowing input power levels as low as -69dBm. The MAX2105 has a reduced AGC range of 41dB and accepts input power levels down to -60dBm. The reduced AGC range of the MAX2105 allows the use of a high-gain external LNA to achieve a lower system noise figure (NF).

## Applications

|                          |                     |
|--------------------------|---------------------|
| DBS Tuners               | Wireless Local Loop |
| DVB-Compliant DBS Tuners | Broadband Systems   |
| Cellular Base Stations   | LMDS                |

## Features

- ◆ Low-Cost Bipolar Design, Lowest Cost Architecture
- ◆ Operate from a Single +5V Supply
- ◆ 950MHz to 2150MHz Input Frequency Range\*
- ◆ On-Chip Quadrature Generator, Dual-Modulus Prescaler (/64, /65)
- ◆ Input Levels
  - 69dBm to -19dBm per Carrier (MAX2102)
  - 60dBm to -19dBm per Carrier (MAX2105)
- ◆ Over 50dB AGC Control Range (MAX2102)
- ◆ Noise Figure = 13.2dB (MAX2102); IP3 = 6.5dBm (at 1450MHz)
- ◆ Automatic Baseband Offset Correction
- ◆ Easy Interface to MAX1002/MAX1003 Dual ADC and Popular Baseband ICs

## Ordering Information

| PART       | TEMP. RANGE  | PIN-PACKAGE |
|------------|--------------|-------------|
| MAX2102CWI | 0°C to +70°C | 28 SO       |
| MAX2105CWI | 0°C to +70°C | 28 SO       |

## Functional Diagram

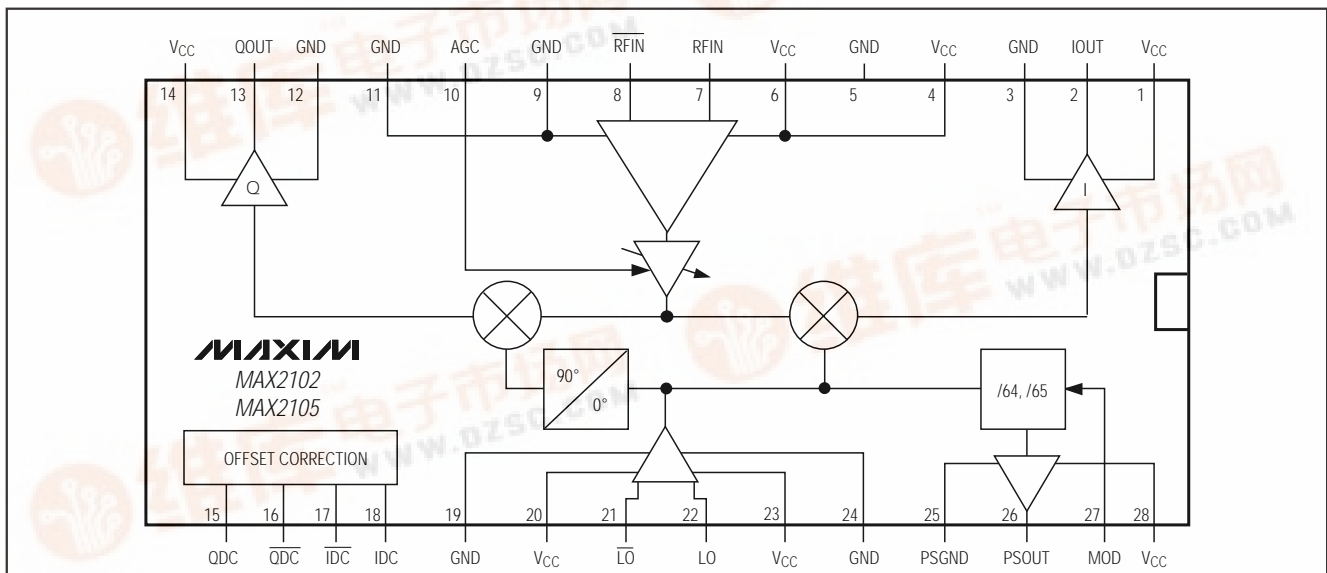

<sup>†</sup> Patents pending

\* Contact factory for MAX2102/MAX2105 versions with expanded frequency range.

MAX2102/MAX2105



# Direct-Conversion Tuner ICs for Digital DBS Applications

## ABSOLUTE MAXIMUM RATINGS

|  |                              |  |                                 |
|--|------------------------------|--|---------------------------------|
| $V_{CC}$ to GND  | -0.5V to +7V                 | IDC, $\overline{IDC}$ , QDC, $\overline{QDC}$ to GND | -0.5V to ( $V_{CC} + 0.5V$ )    |
| RFIN to $\overline{RFIN}$                                      | $\pm 2V$                     | Continuous Power Dissipation ( $T_A = +70^\circ C$ ) |                                 |
| LO to $\overline{LO}$  | $\pm 2V$                     | SO (derate 12.5mW/ $^\circ C$ above $+70^\circ C$ )  | 1.025W                          |
| AGC, MOD, RFIN, $\overline{RFIN}$ , LO, $\overline{LO}$ to GND | -0.5V to ( $V_{CC} + 0.5V$ ) | Operating Temperature Range                          | $0^\circ C$ to $+70^\circ C$    |
| AGC Current  | $\pm 30mA$                   | Junction Temperature                                 | $+150^\circ C$                  |
| IDC to $\overline{IDC}$ , QDC to $\overline{QDC}$              | $\pm 2V$                     | Storage Temperature Range                            | $-65^\circ C$ to $+150^\circ C$ |
| IOUT or QOUT to GND Short-Circuit Duration                     | 10sec                        | Lead Temperature (soldering, 10sec)                  | $+300^\circ C$                  |
| PSOUT to GND Short-Circuit Duration                            | None                         |  |                                 |

Stresses beyond those listed under "Absolute Maximum Ratings" may cause permanent damage to the device. These are stress ratings only, and functional operation of the device at these or any other conditions beyond those indicated in the operational sections of the specifications is not implied. Exposure to absolute maximum rating conditions for extended periods may affect device reliability.

## DC ELECTRICAL CHARACTERISTICS

( $V_{CC} = +4.75V$  to  $+5.25V$ ; GND = 0V; PSGND = GND; AGC = 1.3V; MOD = 0.8V; PRFIN = OFF;  $f_{LO} = 1450.125MHz$ ;  $P_{LO} = -15dBm$ ; IOUT, QOUT = open;  $T_A = 0^\circ C$  to  $+70^\circ C$ ; unless otherwise noted.)

| PARAMETER                        | CONDITIONS                    |                             | MIN  | TYP | MAX  | UNITS   |
|----------------------------------|-------------------------------|-----------------------------|------|-----|------|---------|
| <b>SUPPLY</b>                    |                               |                             |      |     |      |         |
| Operating Supply Voltage Range   |                               |                             | 4.75 |     | 5.25 | V       |
| Quiescent Supply Current         |                               |                             |      | 150 | 195  | mA      |
| <b>CONTROL INPUTS, PRESCALER</b> |                               |                             |      |     |      |         |
| MOD Input Low Level              |                               |                             |      |     | 0.8  | V       |
| MOD Input High Level             |                               |                             | 2.0  |     |      | V       |
| MOD Input Bias Current           | $0V \leq V_{MOD} \leq V_{CC}$ |                             | -80  |     | 10   | $\mu A$ |
| AGC Input Bias Current           | MAX2102                       | $0.5V \leq V_{AGC} \leq 4V$ | -250 |     | 180  | $\mu A$ |
|                                  | MAX2105                       | $1V \leq V_{AGC} \leq 4V$   | -180 |     | 180  |         |
| IOUT, QOUT Common-Mode Voltage   |                               |                             | 2.2  |     | 2.6  | V       |

## AC ELECTRICAL CHARACTERISTICS

(MAX2102 EV kit circuit (Figure 1);  $V_{CC} = +5V$ ; PSGND = open; MOD = GND;  $f_{RFIN} = 2150MHz$ ;  $P_{RFIN} = -19dBm$ ;  $f_{LO} = 2150.125MHz$ ;  $P_{LO} = -15dBm$  driven single-ended into LO; AGC set via servo loop for  $V_{IOUT} = V_{QOUT} = 0.5Vp-p$ ; IOUT, QOUT drive AC-coupled  $100\Omega$  loads;  $2k\Omega$  from PSOUT to GND;  $T_A = +25^\circ C$ ; unless otherwise noted.)

| PARAMETER                               | CONDITIONS  |         | MIN     | TYP | MAX  | UNITS |
|---|---|---------|---------|-----|------|-------|
| <b>RF FRONT END</b>                     |   |         |         |     |      |       |
| RFIN Carrier Frequency Range            | (Note 1)  |         | 950     |     | 2150 | MHz   |
| RFIN Maximum Single-Carrier Input Power | Refers to single-carrier power generating<br>$V_{IOUT} = V_{QOUT} = 0.5Vp-p$ ,<br>$950MHz < f_{RFIN} < 2150MHz$ ,<br>$950MHz < f_{LO} < 2150MHz$ (Note 2) |         | -19     |     |      | dBm   |
| RFIN Minimum Single-Carrier Input Power | Refers to single-carrier power generating<br>$V_{IOUT} = V_{QOUT} = 0.5Vp-p$ ,<br>$950MHz < f_{RFIN} < 2150MHz$ ,<br>$950MHz < f_{LO} < 2150MHz$ (Note 2) | MAX2102 |         |     | -69  | dBm   |
|   |   | MAX2105 |         |     | -60  |       |
| AGC Range                               | $0.5V \leq V_{AGC} \leq 4V$   |         | MAX2102 | 50  |      | dB    |
|   | $1V \leq V_{AGC} \leq 4V$   |         | MAX2105 | 41  |      |       |

# Direct-Conversion Tuner ICs for Digital DBS Applications

MAX2102/MAX2105

## AC ELECTRICAL CHARACTERISTICS

(MAX2102 EV kit circuit (Figure 1);  $V_{CC} = +5V$ ;  $PSGND = open$ ;  $MOD = GND$ ;  $f_{RFIN} = 2150MHz$ ;  $P_{RFIN} = -19dBm$ ;  $f_{LO} = 2150.125MHz$ ;  $P_{LO} = -15dBm$  driven single-ended into LO; AGC set via servo loop for  $V_{IOUT} = V_{QOUT} = 0.5Vp-p$ ; IOUT, QOUT drive AC-coupled  $100\Omega$  loads;  $2k\Omega$  from PSOUT to GND;  $T_A = +25^\circ C$ ; unless otherwise noted.)

| PARAMETER  | CONDITIONS   |  |         | MIN | TYP   | MAX | UNITS |
|--|--|--|---------|-----|-------|-----|-------|
| RFIN Input Third-Order Intercept                     | $P_{RFIN} = -19dBm$ per tone, AGC set via servo loop for $V_{IOUT} = V_{QOUT} = 0.5Vp-p$ per tone, $f_{1RFIN} = 1448.1MHz$ , $f_{2RFIN} = 1449MHz$ , $f_{LO} = 1451MHz$  |  |         |     | 6.5   |     | dBm   |
| RFIN Input Second-Order Intercept                    | $P_{RFIN} = -19dBm$ per tone, AGC set via servo loop for $V_{IOUT} = V_{QOUT} = 0.5Vp-p$ per tone, $f_{1RFIN} = 1200MHz$ , $f_{2RFIN} = 2150MHz$ , $f_{LO} = 951MHz$   |  |         |     | 15.1  |     | dBm   |
| Noise Figure   | $f_{RFIN} = 1441MHz$ ,<br>$f_{LO} = 1451MHz$   | $P_{RFIN} = -69dBm$  | MAX2102 |     | 13.2  |     | dB    |
|  |  | $P_{RFIN} = -60dBm$  | MAX2105 |     | 15.7  |     |       |
|  | $f_{RFIN} = 2141MHz$ ,<br>$f_{LO} = 2151MHz$   | $P_{RFIN} = -69dBm$  | MAX2102 |     | 12.9  |     |       |
|  |  | $P_{RFIN} = -60dBm$  | MAX2105 |     | 15.5  |     |       |
|  |  | AGC = 4V,<br>$P_{RFIN}$ set via servo<br>loop for $V_{IOUT} =$<br>$V_{QOUT} = 0.5Vp-p$ | MAX2102 |     | 11.2  |     |       |
|  |  |  | MAX2105 |     | 11.5  |     |       |
| Maximum Noise-Figure Variation with AGC Gain Setting | Defined as $\Delta NF/\Delta Gain$ ; for AGC range, defined as single-carrier power range of $-69dBm$ to $-59dBm$ (MAX2102) or $-60dBm$ to $-50dBm$ (MAX2105)  |  | MAX2102 |     | -0.5  |     | dB/dB |
|  |  |  | MAX2105 |     | -0.7  |     |       |
| RFIN Worst-Case VSWR across Band                     | $f_{RFIN} = 950MHz$ to $2150MHz$ , $50\Omega$ source   |  |         |     | 2.3:1 |     |       |
| Maximum Power of Spurious Downconversion Products    | $950MHz < f_{RFIN} < 2150MHz$ , $950MHz < f_{LO} < 2150MHz$ . Dominated by LO second-harmonic power causing downconversion of unwanted channel. Test conditions: $f_{LO} = 1075.5MHz$ , $f_{RFIN} = 2150MHz$ , $P_{RFIN} = -69dBm$ (MAX2102) or $-60dBm$ (MAX2105) |  |         |     | -32.3 |     | dBc   |
| LO Leakage at RFIN                                   | $P_{LO} = -15dBm$ , $950MHz < f_{LO} < 2150MHz$ (Note 3)   |  |         |     |       | -49 | dBm   |
|  | $P_{LO} = -15dBm$ , $P_{LO} = -15dBm$ (differentially driven), $950MHz < f_{LO} < 2150MHz$ (Note 3)  |  |         |     |       | -54 |       |

# Direct-Conversion Tuner ICs for Digital DBS Applications

## AC ELECTRICAL CHARACTERISTICS (continued)

(MAX2102 EV kit circuit (Figure 1);  $V_{CC} = +5V$ ;  $PSGND = open$ ;  $MOD = GND$ ;  $f_{RFIN} = 2150MHz$ ;  $PR_{FIN} = -19dBm$ ;  $f_{LO} = 2150.125MHz$ ;  $PL_{O} = -15dBm$  driven single-ended into LO; AGC set via servo loop for  $V_{IOUT} = V_{QOUT} = 0.5V_{p-p}$ ; IOOUT, QOUT drive AC-coupled  $100\Omega$  loads;  $2k\Omega$  from PSOUT to GND;  $T_A = +25^\circ C$ ; unless otherwise noted.)

| PARAMETER   | CONDITIONS  | MIN        | TYP    | MAX  | UNITS   |
|---|---|------------|--------|------|---------|
| <b>OSCILLATOR BUFFER, QUADRATURE GENERATOR, PRESCALER</b> |   |            |        |      |         |
| LO Input Frequency Range                                  | (Note 1)  | 950        |        | 2150 | MHz     |
| LO Input Worst-Case VSWR over Band                        | $f_{LO} = 950MHz$ to $2150MHz$ , $50\Omega$ source into MAX2102 EV kit match circuit  |            | 1.75:1 |      |         |
| LO Input Power Level                                      | (Note 4)  | -15        |        | -5   | dBm     |
|   | Refers to power level driven into LO, $\overline{LO}$ (differentially driven) (Notes 2, 4)  | -15        |        |      |         |
| RFIN to LO Input Isolation                                | (Notes 2, 5)  | 28         |        |      | dB      |
| IOOUT, QOUT Phase Imbalance                               | $950MHz < f_{RFIN} < 2150MHz$ ;<br>$950MHz < f_{LO} < 2150MHz$ ; $PR_{FIN} = -40dBm$ ;<br>$f_{IOOUT}, f_{QOUT} = 125kHz$ (Note 2) |            |        | 3    | degrees |
| Worst-Case Additional Phase Imbalance Over Temperature    | $T_A = +25^\circ C$ to $+70^\circ C$ (Notes 2 and 6)  |            | -0.1   | 0.6  | degrees |
|   | $T_A = +25^\circ C$ to $+0^\circ C$ (Note 2)  |            | -0.07  | 1    |         |
| IOOUT, QOUT Amplitude Imbalance                           | $950MHz < f_{RFIN} < 2150MHz$ ;<br>$950MHz < f_{LO} < 2150MHz$ ; $PR_{FIN} = -40dBm$ ;<br>$f_{IOOUT}, f_{QOUT} = 125kHz$ (Note 2) |            |        | 0.5  | dB      |
| Prescaler Divide Ratio                                    | $T_A = 0^\circ C$ to $+70^\circ C$<br>(Note 2)  | MOD = low  | 64     | 64   |         |
|   |   | MOD = high | 65     | 65   |         |
| Prescaler Output Swing at PSOUT                           | $2k\Omega \parallel 10pF$ load  | 0.8        |        |      | Vp-p    |
| Prescaler Duty Cycle at PSOUT                             | PSOUT load = $2k\Omega \parallel 5pF$ (Note 3)  | 35         |        | 65   | %       |
| <b>BASEBAND AC CHARACTERISTICS</b>                        |   |            |        |      |         |
| IOOUT, QOUT Clipping Level                                | $PR_{FIN} = -50dBm$ ; AGC = 4V, $V_{CC} = 5.0V$   |            | 2.7    |      | Vp-p    |
| Baseband Bandwidth (at IOOUT, QOUT)                       | At -3dB attenuation   |            | 94     |      | MHz     |
| Baseband Gain Ripple (at IOOUT, QOUT)                     | $1kHz < (f_{IOOUT}, f_{QOUT}) < 25MHz$ , $950MHz < f_{RFIN} < 2150MHz$ , $950MHz < f_{LO} < 2150MHz$ (Notes 3, 7, 8)              |            | 0.45   | 0.85 | dB      |
| Baseband Group Delay Ripple (at IOOUT, QOUT)              | $1kHz < (f_{IOOUT}, f_{QOUT}) < 25MHz$ , $950MHz < f_{RFIN} < 2150MHz$ , $950MHz < f_{LO} < 2150MHz$ (Notes 3, 7, 8)              |            | 0.45   |      | ns      |

# Direct-Conversion Tuner ICs for Digital DBS Applications

MAX2102/MAX2105

## AC ELECTRICAL CHARACTERISTICS (continued)

(MAX2102 EV kit circuit (Figure 1);  $V_{CC} = +5V$ ;  $PSGND = open$ ;  $MOD = GND$ ;  $f_{RFIN} = 2150MHz$ ;  $PR_{FIN} = -19dBm$ ;  $f_{LO} = 2150.125MHz$ ;  $P_{LO} = -15dBm$  driven single-ended into LO; AGC set via servo loop for  $V_{IOUT} = V_{QOUT} = 0.5Vp-p$ ; IOOUT, QOUT drive AC-coupled  $100\Omega$  loads;  $2k\Omega$  from PSOUT to GND;  $T_A = +25^\circ C$ ; unless otherwise noted.)

| PARAMETER   | CONDITIONS  | MIN | TYP     | MAX | UNITS    |
|---|---|-----|---------|-----|----------|
| IOOUT, QOUT Output Impedance                            | (Note 3)  |     | 4.7     | 10  | $\Omega$ |
| Maximum IOOUT to QOUT Output Impedance Difference       | (Note 3)  |     | $\pm 1$ |     | $\Omega$ |
| Power-Supply Ripple Rejection (measured at IOOUT, QOUT) | $V_{CC} = 5V + 50mVp-p$ at 300kHz. Amplitude of 300kHz relative to 500mVp-p measured at IOOUT, QOUT. Measured using MAX2102 EV kit. |     | 32      |     | dB       |

- Note 1:** All specifications with guaranteed min/max limits are met within this frequency range. Contact factory for MAX2102/MAX2105 versions with expanded frequency range.
- Note 2:** Guaranteed by production test and/or design and characterization.
- Note 3:** Guaranteed by design and characterization.
- Note 4:** IOOUT, QOUT Phase and Amplitude Imbalance specifications are met within this LO power range.
- Note 5:** Tested under two conditions: 1) Normal test:  $PR_{FIN} = -20dBm$ , and 2) Overdrive test:  $PR_{FIN} = -5dBm$  but AGC set via servo loop for  $V_{IOUT} = V_{QOUT} = 0.5Vp-p$  for  $PR_{FIN} = -30dBm$ .
- Note 6:** Negative numbers (-0.1°) indicate improvement in quadrature accuracy with increasing temperature.
- Note 7:** Includes contribution from front-end gain tilt and delay variations produced by varying  $f_{RFIN}$  by  $\pm 30MHz$ .
- Note 8:** 1kHz minimum frequency determined by 0.22 $\mu F$  offset-correction capacitors. Different value capacitors yield proportionally different low-frequency cutoffs. Group delay at low frequencies will also be affected. See *Applications Information* section.

## Typical Operating Characteristics

(MAX2102 EV kit circuit (Figure 1),  $V_{CC} = 5V$ ,  $PSGND = open$ ,  $MOD = GND$ ,  $f_{RFIN} = 2150MHz$ ,  $PR_{FIN} = -19dBm$ ,  $f_{LO} = 2150.125MHz$ ,  $P_{LO} = -15dBm$  driven single-ended into LO, AGC set via servo loop for  $V_{IOUT} = V_{QOUT} = 0.5Vp-p$ , IOOUT, QOUT drive AC-coupled  $100\Omega$  loads,  $2k\Omega$  from PSOUT to GND,  $T_A = +25^\circ C$ , unless otherwise noted.)

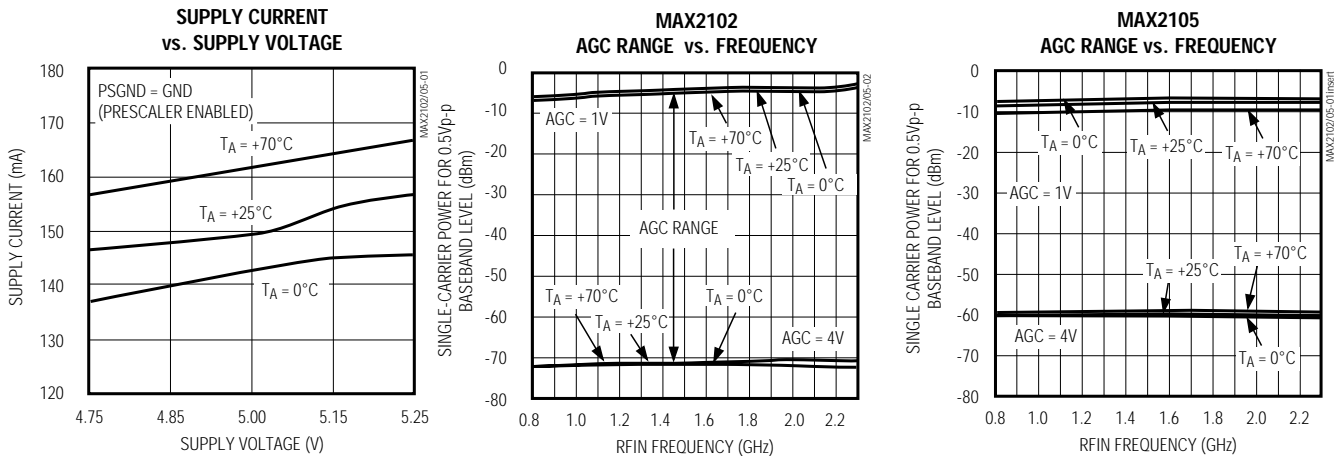

# Direct-Conversion Tuner ICs for Digital DBS Applications

## Typical Operating Characteristics (continued)

(MAX2102 EV kit circuit (Figure 1),  $V_{CC} = 5V$ ,  $PSGND = open$ ,  $MOD = GND$ ,  $f_{RFIN} = 2150MHz$ ,  $P_{RFIN} = -19dBm$ ,  $f_{LO} = 2150.125MHz$ ,  $P_{LO} = -15dBm$  driven single-ended into LO, AGC set via servo loop for  $V_{IOUT} = V_{OOUT} = 0.5Vp-p$ , IOUT, QOUT drive AC-coupled  $100\Omega$  loads,  $2k\Omega$  from PSOUT to GND,  $T_A = +25^\circ C$ , unless otherwise noted.)

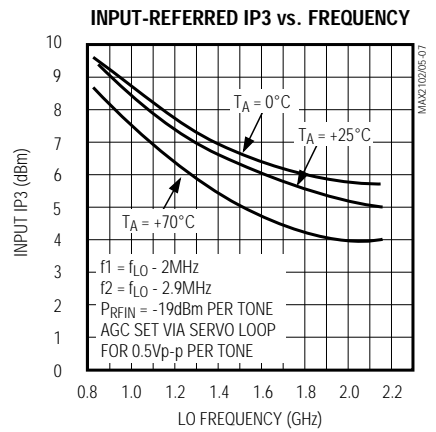
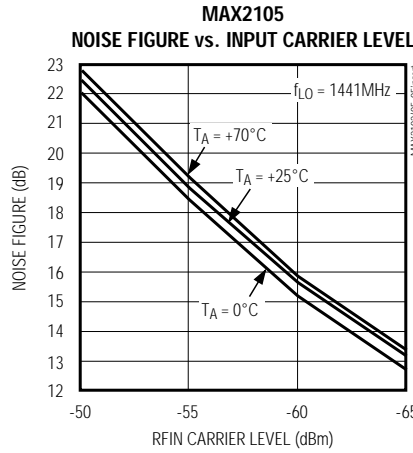
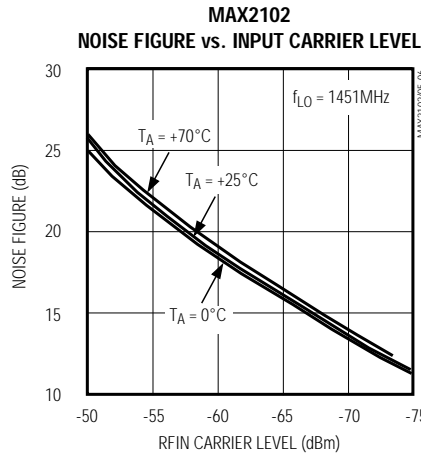
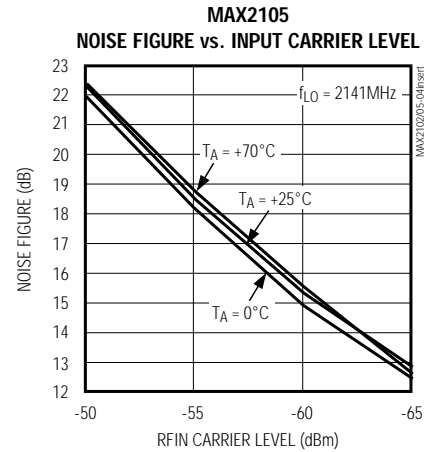
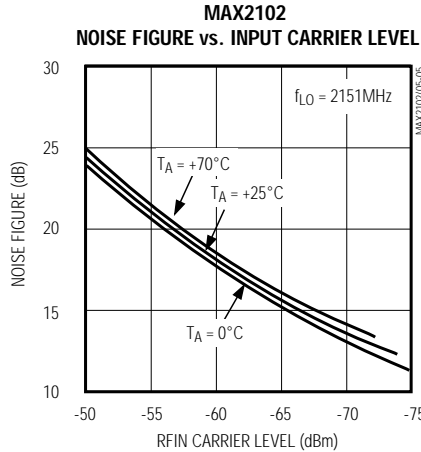
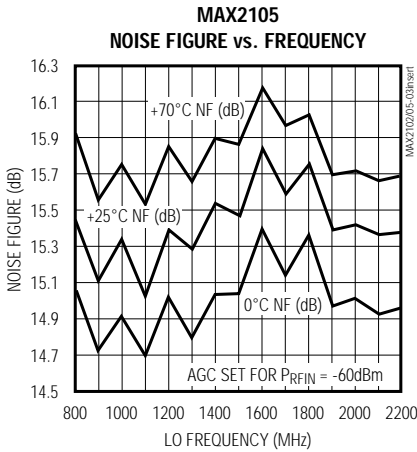
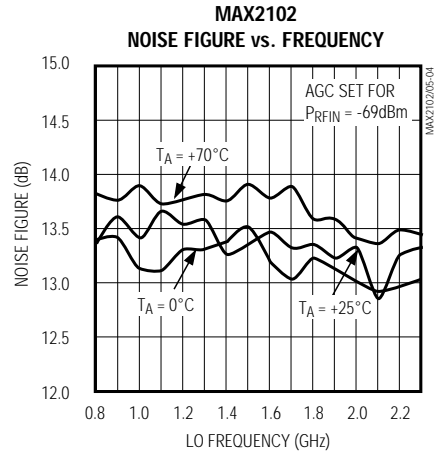
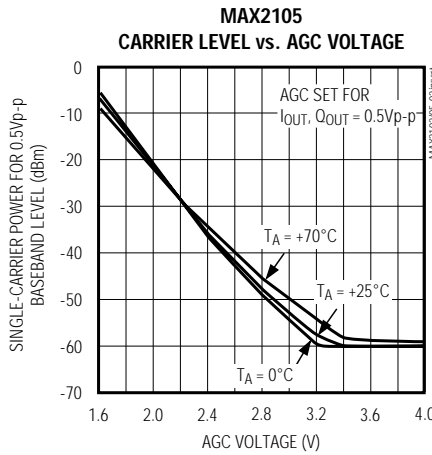
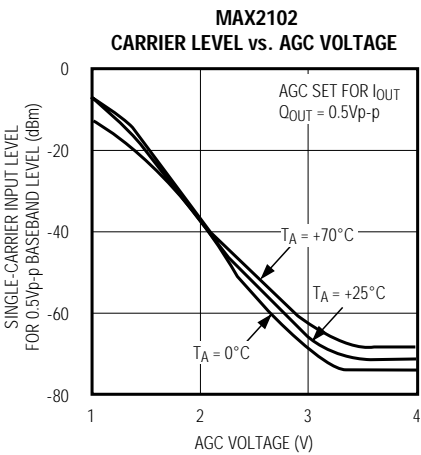

# Direct-Conversion Tuner ICs for Digital DBS Applications

## Typical Operating Characteristics (continued)

(MAX2102 EV kit circuit (Figure 1),  $V_{CC} = 5V$ ,  $PSGND = open$ ,  $MOD = GND$ ,  $f_{RFIN} = 2150MHz$ ,  $P_{RFIN} = -19dBm$ ,  $f_{LO} = 2150.125MHz$ ,  $P_{LO} = -15dBm$  driven single-ended into LO, AGC set via servo loop for  $V_{IOUT} = V_{OOUT} = 0.5Vp-p$ , IOUT, QOUT drive AC-coupled  $100\Omega$  loads,  $2k\Omega$  from PSOUT to GND,  $T_A = +25^\circ C$ , unless otherwise noted.)

MAX2102/MAX2105

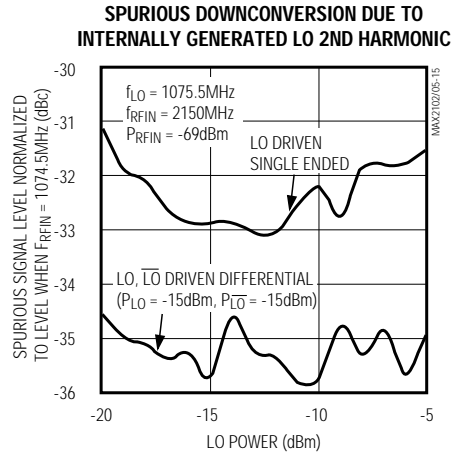
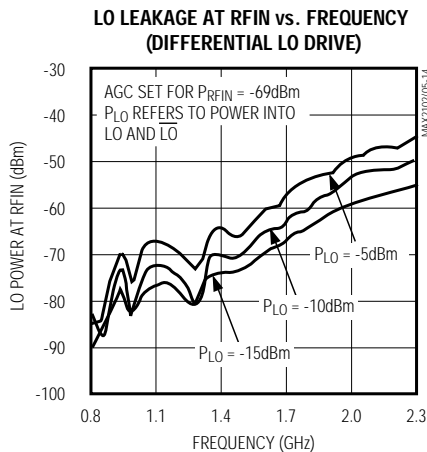
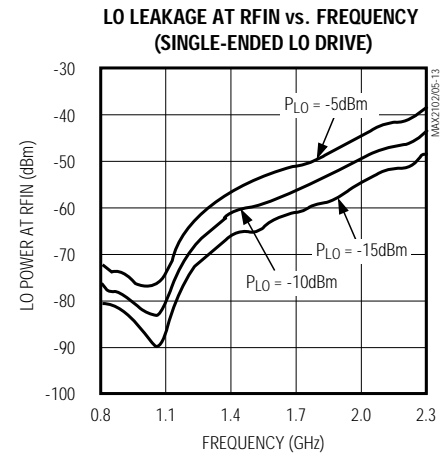
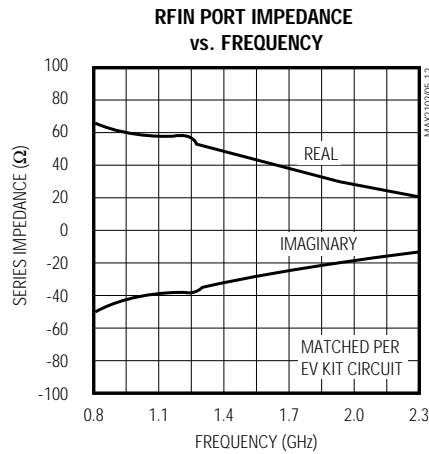
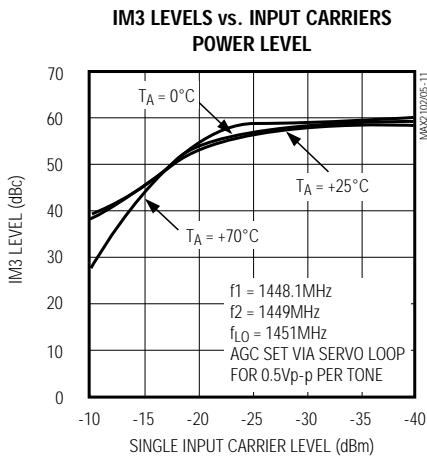
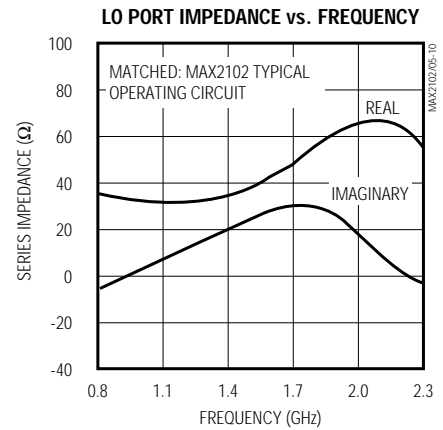
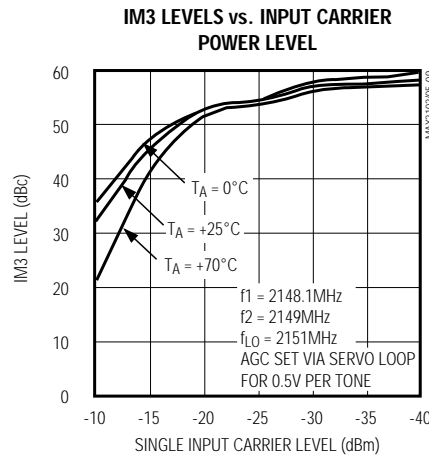
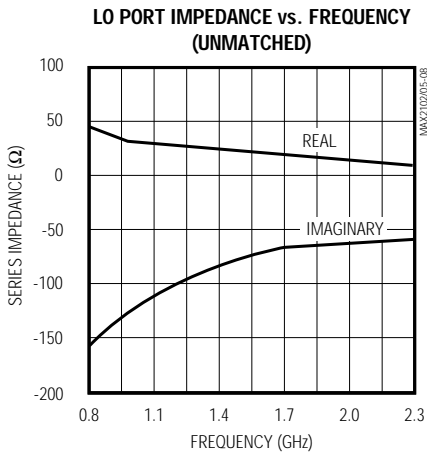

# Direct-Conversion Tuner ICs for Digital DBS Applications

## Typical Operating Characteristics (continued)

(MAX2102 EV kit circuit (Figure 1),  $V_{CC} = 5V$ ,  $PSGND = open$ ,  $MOD = GND$ ,  $f_{RFIN} = 2150MHz$ ,  $P_{RFIN} = -19dBm$ ,  $f_{LO} = 2150.125MHz$ ,  $P_{LO} = -15dBm$  driven single-ended into LO, AGC set via servo loop for  $V_{IOUT} = V_{QOUT} = 0.5Vp-p$ , IOUT, QOUT drive AC-coupled  $100\Omega$  loads,  $2k\Omega$  from PSOUT to GND,  $T_A = +25^\circ C$ , unless otherwise noted.)

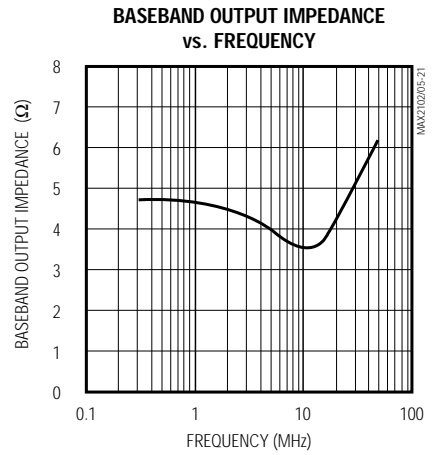
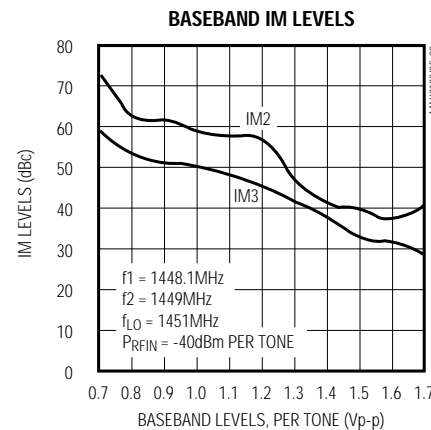
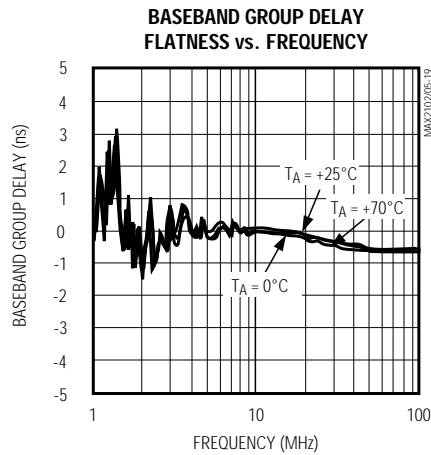
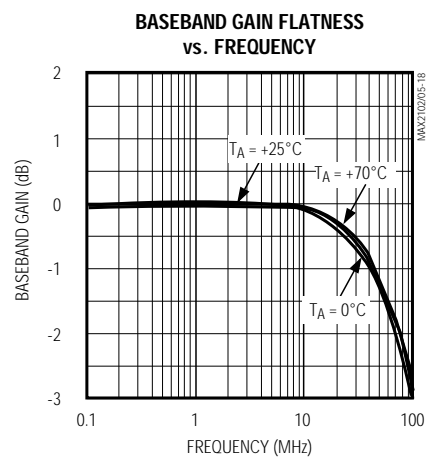
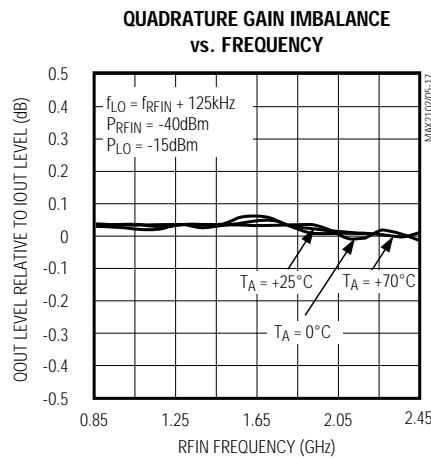
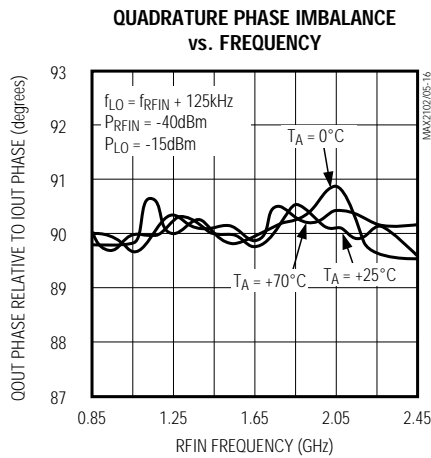



# Direct-Conversion Tuner ICs for Digital DBS Applications

## Pin Description

MAX2102/MAX2105

| PIN           | NAME            | FUNCTION  |
|---------------|-----------------|---|
| 1             | V <sub>CC</sub> | Baseband +5V Supply. Bypass with a 10pF capacitor from this pin to pin 3 (GND), as close to the IC as possible. Connect an additional 0.1μF capacitor in parallel with the 10pF capacitor (placement less critical).  |
| 2             | IOUT            | I Channel Baseband Output   |
| 3, 12         | GND             | Baseband Ground   |
| 4             | V <sub>CC</sub> | RF +5V Supply. Bypass with a 22pF capacitor from this pin to pin 11 (GND), as close to the IC as possible.  |
| 5             | GND             | Ground (substrate)  |
| 6             | V <sub>CC</sub> | RF +5V Supply. Bypass with a 22pF capacitor from this pin to pin 9 (GND), as close to the IC as possible.   |
| 7             | RFIN            | RF Noninverting Input. Couple through a 22pF capacitor directly to a 50Ω signal source.   |
| 8             | RFIN            | RF Inverting Input. Connect to a 22pF series capacitor and a 51Ω resistor to ground.  |
| 9, 11, 19, 24 | GND             | RF Ground. Connect directly to the ground plane.  |
| 10            | AGC             | Automatic Gain-Control Input. Bypass this pin with a 1000pF capacitor close to the pin, to minimize coupling.   |
| 13            | QOUT            | Q Channel Baseband Output   |
| 14            | V <sub>CC</sub> | Baseband +5V Supply. Bypass with a 10pF capacitor from this pin to pin 12 (GND), as close to the IC as possible. Connect an additional 0.1μF capacitor in parallel with the 10pF capacitor (placement less critical). |
| 15            | QDC             | Q Channel Offset-Correction Noninverting Input. Connect a 0.22μF (typ) capacitor between QDC and QDC̄. This capacitor must be placed as close to the IC as possible (see <i>Layout Considerations</i> section).       |
| 16            | QDC̄            | Q Channel Offset-Correction Inverting Input. Connect a 0.22μF (typ) capacitor between QDC and QDC̄. This capacitor must be placed as close to the IC as possible (see <i>Layout Considerations</i> section).          |
| 17            | IDC̄            | I Channel Offset-Correction Inverting Input. Connect a 0.22μF (typ) capacitor between IDC and IDC̄. This capacitor must be placed as close to the IC as possible (see <i>Layout Considerations</i> section).          |
| 18            | IDC             | I Channel Offset-Correction Noninverting Input. Connect a 0.22μF (typ) capacitor between IDC and IDC̄. This capacitor must be placed as close to the IC as possible (see <i>Layout Considerations</i> section).       |
| 20            | V <sub>CC</sub> | RF +5V Supply. Bypass with a 10pF capacitor from this pin to pin 19 (GND) as close to the IC as possible.   |
| 21            | LŌ             | Local-Oscillator Complementary Input Port (Figure 1)  |
| 22            | LO              | Local-Oscillator Input Port (Figure 1)  |
| 23            | V <sub>CC</sub> | RF +5V Supply. Bypass with a 10pF capacitor from this pin to pin 24 (GND) as close to the IC as possible.   |
| 25            | PSGND           | Prescaler Ground. To disable the prescaler, leave this pin open.  |
| 26            | PSOUT           | Prescaler Output. Drives CMOS load. Connect 2kΩ from this pin to GND (if the prescaler is enabled).   |
| 27            | MOD             | Prescaler Modulus Control. Leave open when the prescaler is disabled.   |
| 28            | V <sub>CC</sub> | Prescaler +5V Supply. <b>Must be connected even if the prescaler is disabled.</b> Bypass with a 1000pF capacitor.   |

# Direct-Conversion Tuner ICs for Digital DBS Applications

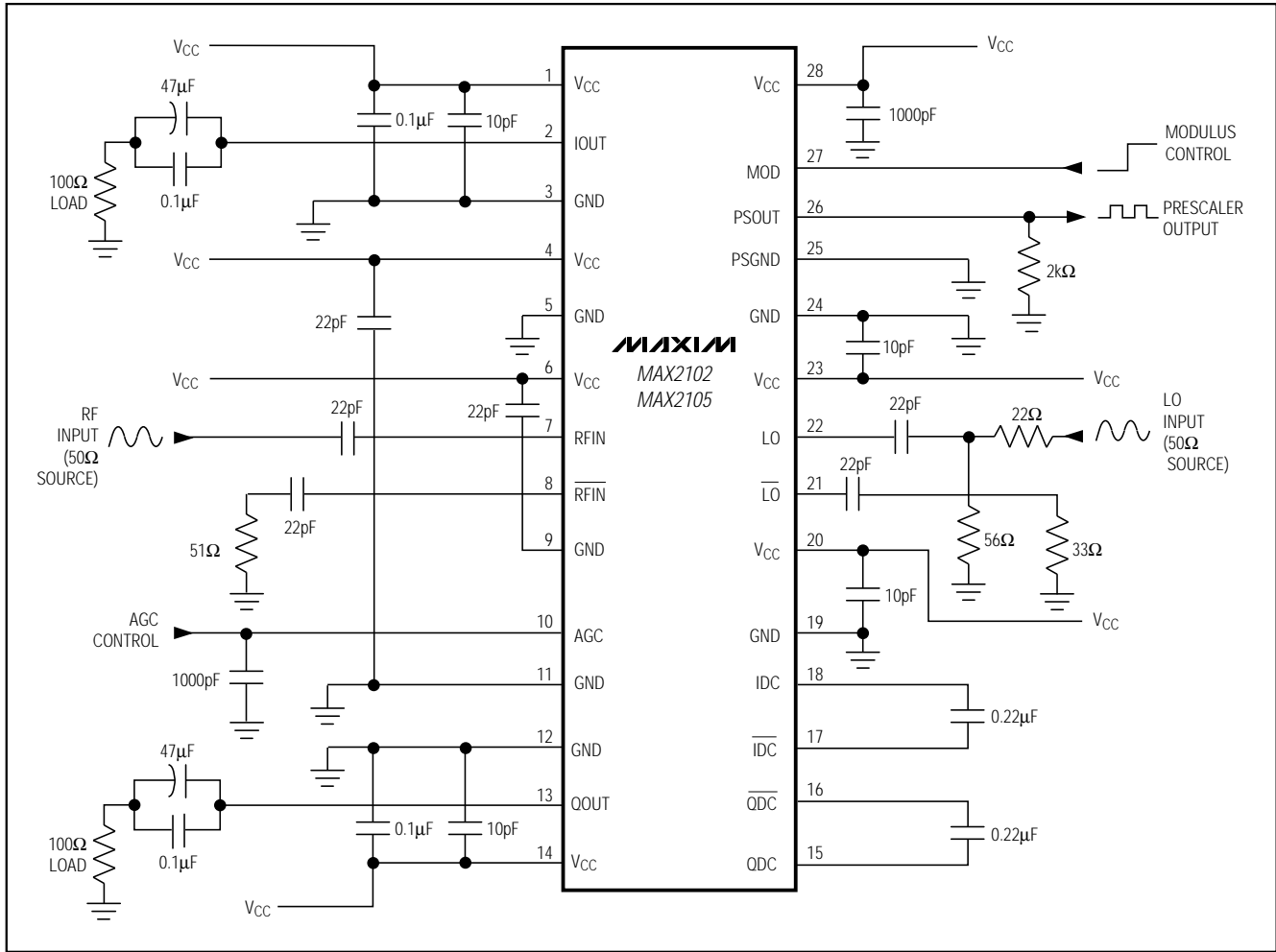

Figure 1. Typical Operating Circuit

## Detailed Description

The MAX2102/MAX2105 down-convert signals in the range 950MHz to 2150MHz directly to baseband I/Q signals. They are targeted for digital DBS tuner applications where a direct downconversion provides a cost savings over prior-art, multiple-conversion approaches. However, the MAX2102/MAX2105 are applicable to any system requiring a broadband I/Q downconversion.

Internally, the MAX2102 and MAX2105 consist of a broadband front-end variable gain stage, a quadrature downconverter, an oscillator buffer, high-linearity I and Q baseband amplifiers, and offset correction amplifiers.

The MAX2102 features a front-end AGC dynamic range of over 50dB, while the MAX2105 provides a front-end

AGC dynamic range of over 41dB. Specifically, the AGC control can be adjusted so that a sine wave at RFIN ranging in power from -69dBm to -19dBm (MAX2102) or -60dBm to -19dBm (MAX2105) will produce a sine wave at IOUT and QOUT at 500mVp-p levels. The noise figure is lowest when the AGC is at its maximum gain setting (see *Typical Operating Characteristics*). The VSWR at RFIN is unaffected by the AGC setting.

The local-oscillator (LO) buffer accepts an external LO signal at LO,  $\overline{\text{LO}}$ , and internally limits the signal to provide a consistent on-chip LO level. The LO input drive level should be maintained within the specified limits (see *Applications Information* section).

# Direct-Conversion Tuner ICs for Digital DBS Applications

MAX2102/MAX2105

The quadrature downconverter follows the front-end AGC. Two mixers are driven by the previous stage AGC amplifier output. The mixer LO ports are fed with the two LO signals, which are 90° apart in phase. These quadrature LO signals are generated on-chip using the LO signal from the LO buffer.

The resulting I/Q baseband signals are fed through separate I and Q channel baseband amplifiers. Robust output stages drive IOU and QOUT. The outputs are capable of driving lowpass filters with 100Ω character-

istic impedance (that is, the equivalent of an AC-coupled, 100Ω load). The baseband -3dB output bandwidth is over 90MHz.

## Applications Information

### Front-End Tuner Circuitry for DBS Tuners

In a typical application, the signal path ahead of the MAX2102/MAX2105 will include a discrete LNA/buffer and a PIN-diode attenuator. Alternatively, a dual-gate

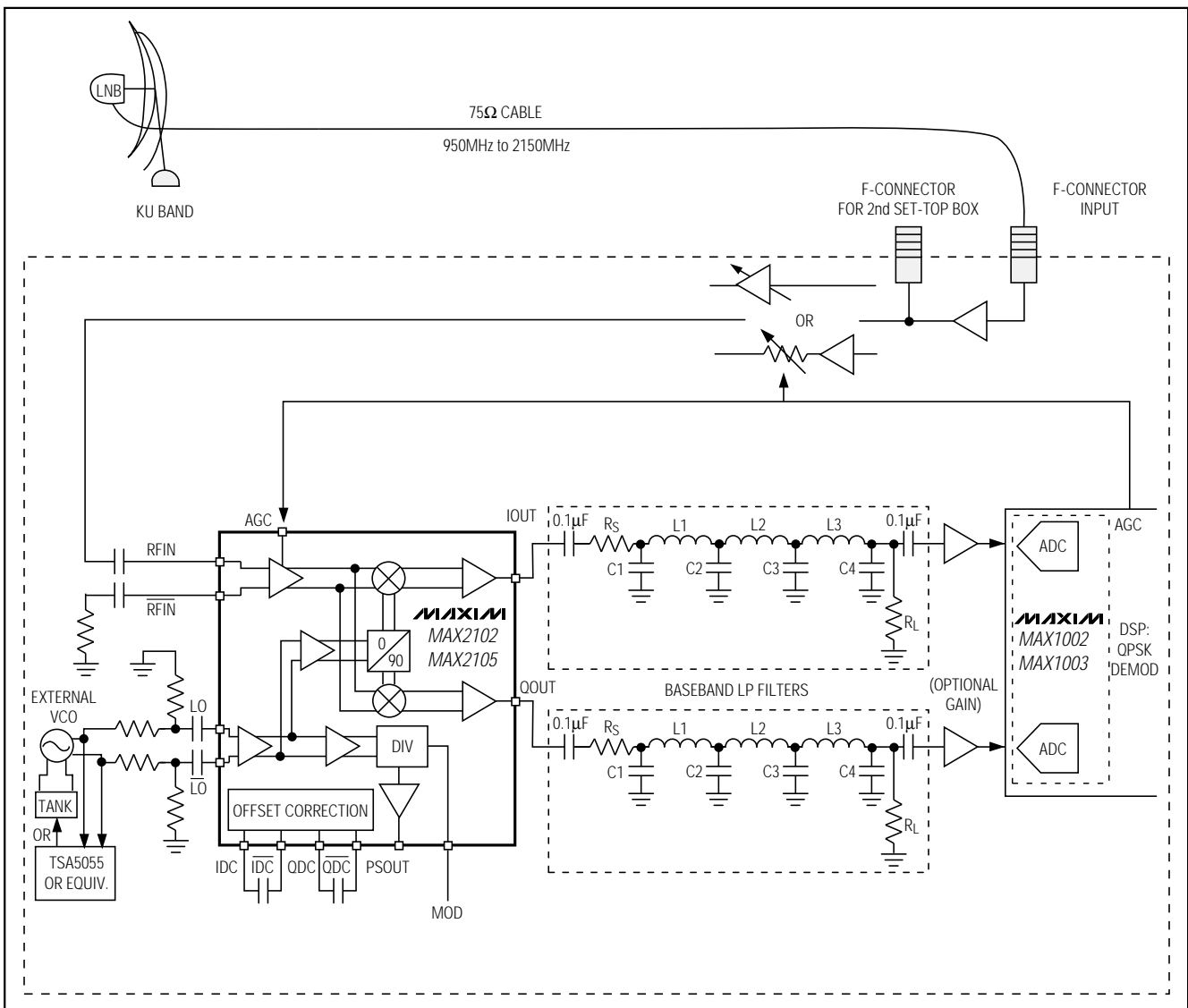

Figure 2. Typical Application

## Direct-Conversion Tuner ICs for Digital DBS Applications

GaAsFET can serve this function. This circuitry is usually required in order to meet system noise-figure requirements, may provide a buffered F-connector output, and may also be required to meet stringent LO leakage requirements. The PIN attenuator is typically controlled by the same voltage as the MAX2102/MAX2105 AGC control pin so that, overall, a single AGC line from the baseband processor can control the entire tuner.

In some applications, a varactor-tuned preselection bandpass filter is added between the discrete LNA and the MAX2102/MAX2105. This is usually required only for very high-linearity tuners, such as those designed for single channel-per-carrier (low-data-rate) applications. The filter provides a means of broadly filtering adjacent interferers, thus improving the tuner's intermodulation performance. Additionally, the filter removes the RF interference at twice the LO frequency, which would otherwise add to cochannel interference (the MAX2102/MAX2105 alone reject this carrier to typically -32.3dBc).

### External Oscillator

Since the MAX2102/MAX2105 are direct-conversion receivers, the external LO must tune to the same frequencies as the desired RF input signals.

The MAX2102/MAX2105 oscillator input port (LO,  $\overline{\text{LO}}$ ) accepts either a single-ended or differential (balanced) LO signal. A differential LO offers reduced LO leakage to the RFIN port, as well as lower spurious downconversion levels of RF signals, which are at twice the LO frequency. Refer to Figure 3 for differential LO connections. For best performance, ensure that the LO and  $\overline{\text{LO}}$  traces are symmetrical.

The LO drive levels should be maintained to within the specified limits. If the LO drive falls below the specified range, quadrature performance may be affected. Driving LO above the specified limits will cause a higher LO leakage level at RFIN; this may be acceptable in some applications. The MAX2102/MAX2105 offset-correction loop can withstand LO leakage levels corresponding to at least 0dBm of LO input power drive.

### Prescaler

Typical stand-alone tuner applications will not use the MAX2102/MAX2105 prescaler function, but instead use a commercial synthesizer IC such as the Philips TSA5055, which has an internal prescaler. To disable the MAX2102/MAX2105 prescaler, disconnect the PSGND pin (leave open). The prescaler will cause an output spur in the baseband spectrum, to a level of about -20dBc (referred to 500mVp-p baseband output level) that may land within the desired signal bandwidth in some applications.

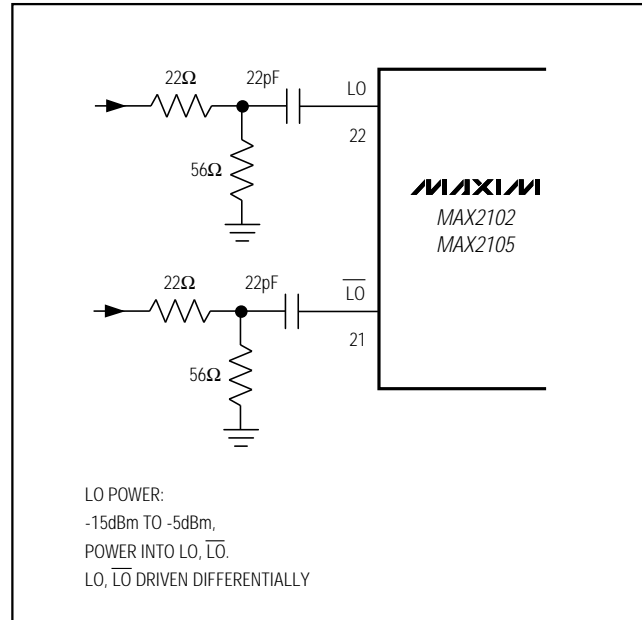

Figure 3. Differential LO Drive

To use the MAX2102/MAX2105 prescaler, connect the PSGND pin to ground. In some applications, the prescaler may be toggled on and off using a MOSFET to switch PSGND to ground. PSGND should be forced to within 100mV of ground, and the MOSFET must be capable of sinking 15mA. PSOUT is capable of driving a typical CMOS load of 10k $\Omega$  in parallel with 5pF. A 2k $\Omega$  pull-down resistor must be connected from PSOUT to GND.

The prescaler requires a stable level at the MOD pin 12ns before the falling edge of PREOUT to assert the desired modulus. The level at MOD must remain static until 3ns after this falling edge.

### Baseband Amplifiers

The MAX2102/MAX2105 baseband amplifiers provide over 2Vp-p swing at IOUT and QOUT, and are capable of driving 100 $\Omega$ . IOUT and QOUT must be AC-coupled to any lowpass filters. In a typical application, IOUT and QOUT drive a 5th or 7th-order lowpass filter for ADC anti-aliasing purposes (see the *Systems Considerations: Lowpass Filters in Direct-Conversion Tuners* section). After the filters, in some cases, additional gain may be required. This can be accomplished with a pair of video-speed op amps, such as the MAX4216 dual-video op amp. Alternatively, the MAX1002/MAX1003 dual ADC has built-in gain ahead of the ADCs, digitizing levels as low as 125mVp-p. Contact Maxim for more information about the MAX4216 or the MAX1002/MAX1003.

## Direct-Conversion Tuner ICs for Digital DBS Applications

### Offset Correction

The internal offset-correction amplifiers remove the DC offsets present in the baseband amplifiers. The offset-correction loop effectively AC-couples the baseband signal path, yielding a -3dB highpass corner frequency according to the following:

$$f_{-3dB} = 100/C_{DC} (\mu F)$$

where  $C_{DC}$  is the value of the capacitors, in microfarads, across QDC,  $\overline{QDC}$  and IDC,  $\overline{IDC}$ .

For applications where the DC information must be maintained through the signal path, the offset correction can be disabled by connecting QDC,  $\overline{QDC}$ , IDC, and  $\overline{IDC}$  directly to ground. Disabling the offset correction will effectively limit the input dynamic range of the MAX2102/MAX2105. Typical input dynamic range will be approximately -45dBm to -19dBm for single-ended LO drive, and -55dBm to -19dBm for differential LO drive.

### Layout Considerations

Observe standard RF layout rules. A ground plane is essential; when connecting areas of ground plane between layers, use vias liberally. Remove the ground

plane under the external VCO area to reduce parasitic capacitance. If a ground plane is used under the low-pass filters, note that the filter shape may be slightly offset due to parasitic capacitance.

In a direct-conversion receiver, LO leakage to the RF input connector is a major issue, since filtering of the LO is impossible (the LO operates at the same frequency as the RF input). The external VCO section should be housed in a separate shielded compartment, if possible. Use of a differential (balanced) LO will dramatically reduce LO leakage. Also, the use of coplanar, waveguide transmission-line structures reduces LO leakage (used on the MAX2102 EV kit).

Observe the power-supply bypass capacitor connections in the *Pin Description* table, notably pins 1, 3, 4, 6, 9, 11, 12, 14, 19, 20, 23, and 24. Traces from these IC pins to the bypass capacitors must be kept to an absolute minimum. Where possible, make these connections on the top side of the board.

The MAX2102 EV kit includes ferrite beads in series with power-supply leads. The beads may not be required for all applications.

**Table 1. Suggested Component Values for Discrete Lowpass Filters (0.1dB Ripple Chebyshev Type)**

| ADC SAMPLING RATE (MSPS) | FILTER TYPE                           | $R_s$ ( $\Omega$ ) | C1 (pF) | L1 (nH) | C2 (pF) | L2 (nH) | C3 (pF) | L3 (nH) | C4 (pF) | $R_L$ (k $\Omega$ ) |
|--------------------------|---------------------------------------|--------------------|---------|---------|---------|---------|---------|---------|---------|---------------------|
| 40                       | 0.1dB Chebyshev, $f_c = 20\text{MHz}$ | 100                | 39      | 910     | 120     | 1500    | 150     | 1500    | 120     | 10                  |
| 60                       | 0.1dB Chebyshev, $f_c = 30\text{MHz}$ | 100                | 22      | 620     | 82      | 910     | 100     | 1000    | 82      | 10                  |
| 90                       | 0.1dB Chebyshev, $f_c = 45\text{MHz}$ | 100                | 18      | 390     | 56      | 620     | 68      | 680     | 56      | 10                  |

**Note:** Suggested types: Inductors: Coilcraft 1008CS, tolerance =  $\pm 5\%$ ; Capacitors: use tolerance =  $\pm 2\%$ . Refer to Figure 2 for circuit diagram.

# Direct-Conversion Tuner ICs for Digital DBS Applications

## Power-Supply Sequencing

The MAX2102/MAX2105 have several +5V supply pins. The supply layout should be in a star format, with a bypass capacitor that dominates the rise time of the supply at the center of the star, to ensure that all pins see approximately the same voltage during power-up.

The prescaler V<sub>CC</sub> (pin 28) must be connected to the same V<sub>CC</sub> as the other V<sub>CC</sub> pins, even if the prescaler is not used. Leaving PSGND open will disable the prescaler function and, in this state, the prescaler will not dissipate any power.

## Systems Consideration: Lowpass Filters in Direct-Conversion Tuners

Typically, a 5th or 7th-order L-C lowpass filter is used for anti-aliasing the ADCs following the MAX2102. Figures 4 and 5 describe typical filtering requirements. Table 1 offers suggested component values for these lowpass filters.

## Chip Information

TRANSISTOR COUNT: 1852

SUBSTRATE CONNECTED TO GND

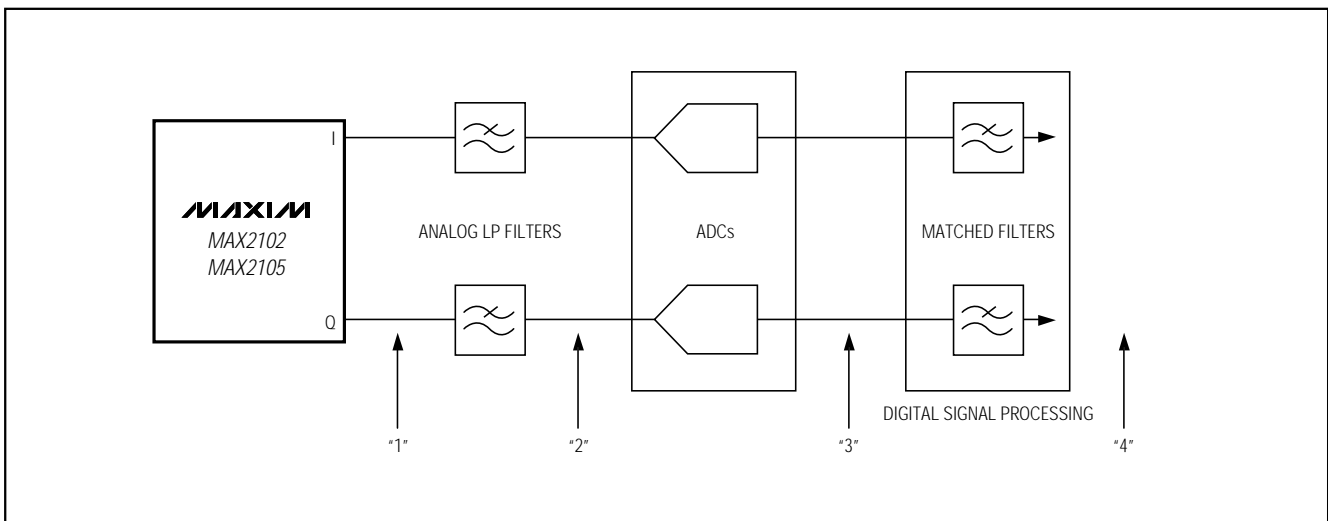

Figure 4. I, Q Signal Path

# Direct-Conversion Tuner ICs for Digital DBS Applications

MAX2102/MAX2105

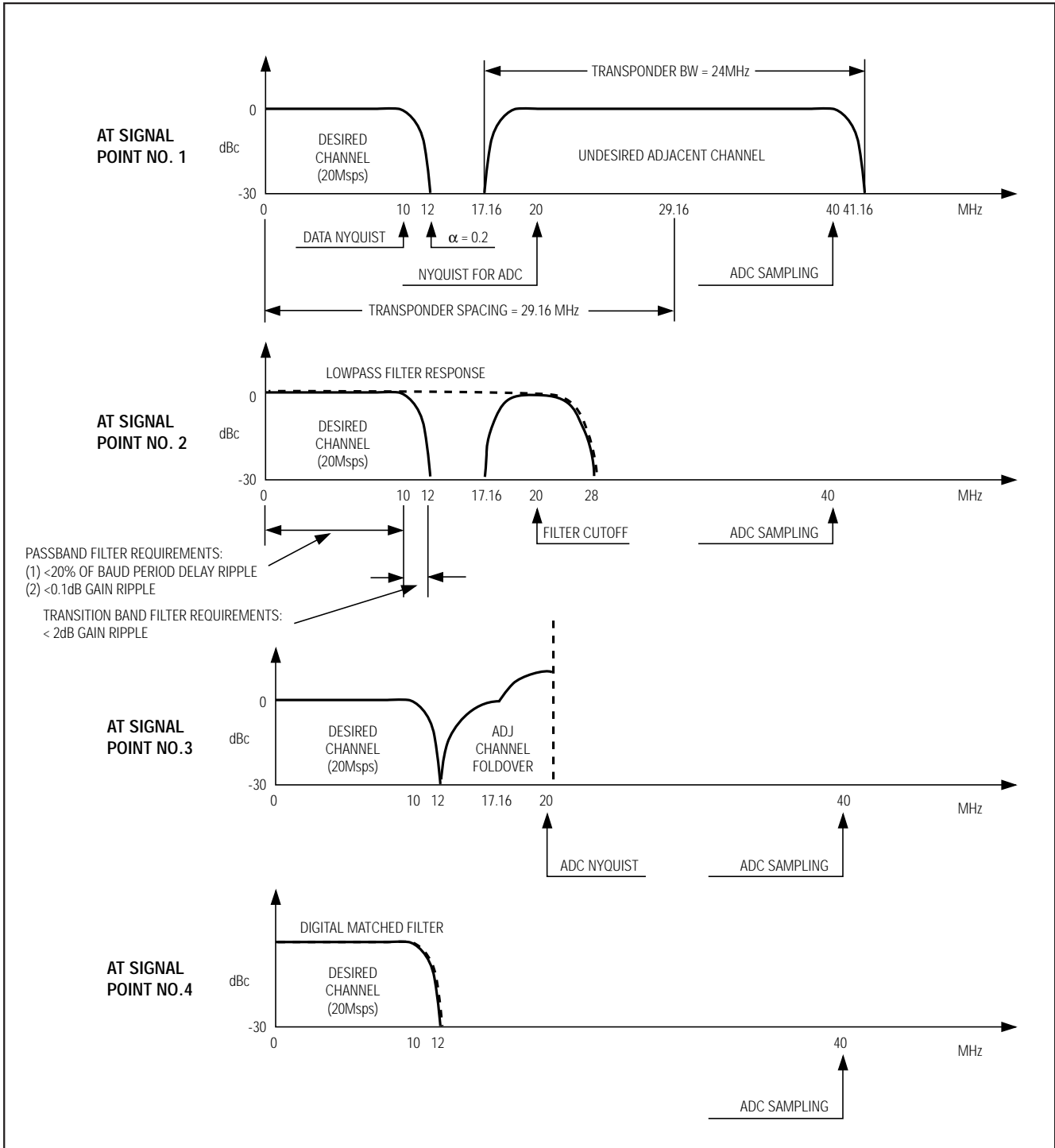
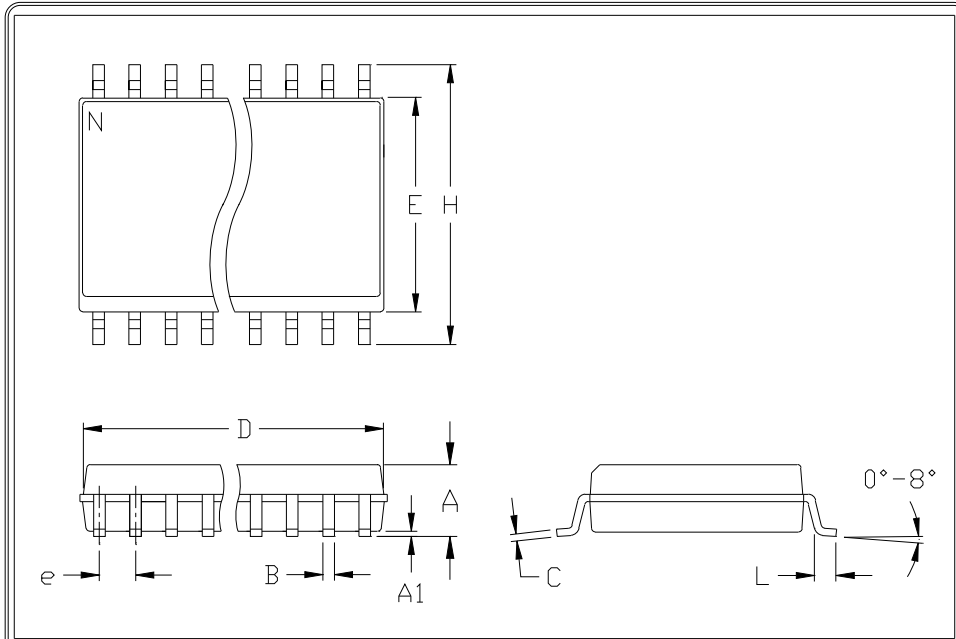

Figure 5. Lowpass Filtering Example. **Note:** Data Rate = 40Mbps, Transponder BW = 24MHz, Transponder Spacing = 29.16MHz, Nyquist Filter:  $\alpha = 0.2$

# Direct-Conversion Tuner ICs for Digital DBS Applications

## Package Information



|    | INCHES |       | MILLIMETERS |       |
|----|--------|-------|-------------|-------|
|    | MIN    | MAX   | MIN         | MAX   |
| A  | 0.093  | 0.104 | 2.35        | 2.65  |
| A1 | 0.004  | 0.012 | 0.10        | 0.30  |
| B  | 0.014  | 0.019 | 0.35        | 0.49  |
| C  | 0.009  | 0.013 | 0.23        | 0.32  |
| e  | 0.050  |       | 1.27        |       |
| E  | 0.291  | 0.299 | 7.40        | 7.60  |
| H  | 0.394  | 0.419 | 10.00       | 10.65 |
| h  | 0.010  | 0.030 | 0.25        | 0.75  |
| L  | 0.016  | 0.050 | 0.40        | 1.27  |

|   | INCHES |       | MILLIMETERS |       | N  | MS013 |
|---|--------|-------|-------------|-------|----|-------|
|   | MIN    | MAX   | MIN         | MAX   |    |       |
| D | 0.398  | 0.413 | 10.10       | 10.50 | 16 | AA    |
| D | 0.447  | 0.463 | 11.35       | 11.75 | 18 | AB    |
| D | 0.496  | 0.512 | 12.60       | 13.00 | 20 | AC    |
| D | 0.598  | 0.614 | 15.20       | 15.60 | 24 | AD    |
| D | 0.697  | 0.713 | 17.70       | 18.10 | 28 | AE    |

- NOTES:
1. D&E DO NOT INCLUDE MOLD FLASH
  2. MOLD FLASH OR PROTRUSIONS NOT TO EXCEED .15mm (.006")
  3. LEADS TO BE COPLANAR WITHIN .102mm (.004")
  4. CONTROLLING DIMENSION: MILLIMETER
  5. MEETS JEDEC MS013-XX AS SHOWN IN ABOVE TABLE
  6. N = NUMBER OF PINS

|  |                                    |  |  |
|--|------------------------------------|--|--|
| <br><small>120 SAN GABRIEL DR. SUNNYVALE CA 94086 FAX 408 737 7794</small><br><small>PROPRIETARY INFORMATION</small> | PACKAGE FAMILY OUTLINE: SOIC .300" |  | 21-0042 A                                  |
|  |                                    |  | <small>DOCUMENT CONTROL NUMBER REV</small> |