

19-4792; Rev 1; 1/99

EVALUATION KIT
AVAILABLE

MAXIM

**+3.3V, 2.125Gbps/1.0625Gbps
Fibre Channel Port Bypass ICs**

General Description

The MAX3750/MAX3751 are +3.3V, Fibre Channel port bypass ICs that include a high-speed multiplexer and output buffer stage for hot swapping a storage device. These devices are optimized for use in a Fibre Channel arbitrated loop topology.

The MAX3750 has a 2.125Gbps data rate, while the MAX3751's data rate is 1.0625Gbps. Total power consumption (including output currents) is low: just 190mW for the MAX3750 and 180mW for the MAX3751. Low 10ps jitter makes these devices ideal for cascaded topologies. The output driver circuitry is tolerant of load mismatches commonly caused by board vias and inductive connectors. On-chip termination reduces external part count and simplifies board layout.

Applications

- 2.125Gbps Fibre Channel Arbitrated Loop
- 1.0625Gbps Fibre Channel Arbitrated Loop
- Mass Storage Systems
- RAID/JBOD Applications

Features

- ◆ Single +3.3V Supply
- ◆ Low Jitter: 10ps
- ◆ Low Power Consumption
190mW (MAX3750)
180mW (MAX3751)
- ◆ Large Output Signal Swing: >1000mVp-p
- ◆ Mismatch Tolerant Output Driver Stage
- ◆ 150Ω Differential On-Chip Termination on All Inputs
- ◆ 150Ω On-Chip Back Termination on All Output Ports

Ordering Information

PART	TEMP. RANGE	PIN-PACKAGE
MAX3750CEE	0°C to +70°C	16 QSOP
MAX3751CEE	0°C to +70°C	16 QSOP

MAX3750/MAX3751

Typical Application Circuit

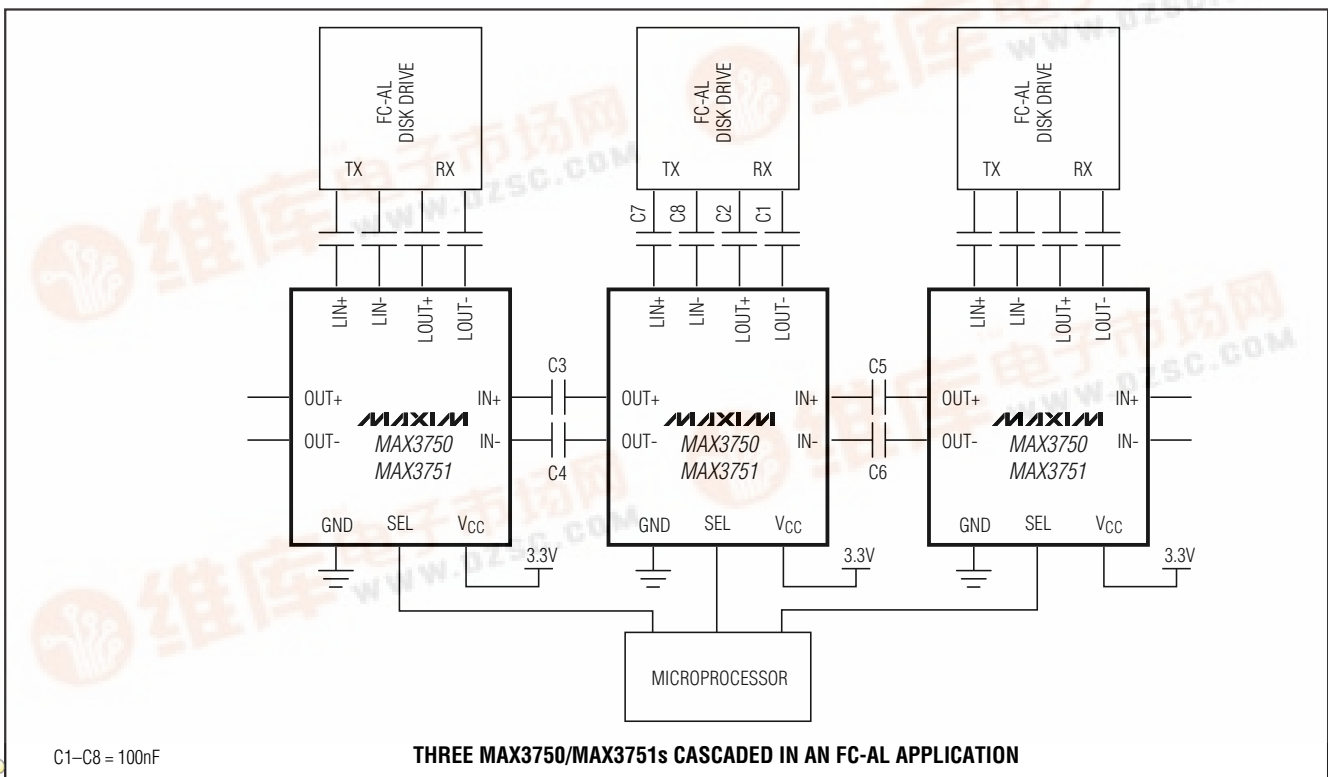

Pin Configuration appears at end of data sheet.

+3.3V, 2.125Gbps/1.0625Gbps Fibre Channel Port Bypass ICs

ABSOLUTE MAXIMUM RATINGS

Supply Voltage, V_{CC}-0.5V to +5.0V
 Voltage at LOUT+, LOUT-,
 OUT+, OUT-($V_{CC} - 1.65V$) to ($V_{CC} + 0.5V$)
 Current Out of LOUT+, LOUT-, OUT+, OUT- $\pm 22mA$
 Voltage at SEL, LIN+, LIN-, IN+, IN--0.5V to ($V_{CC} + 0.5V$)
 Differential Voltage at (LIN+ - LIN-), (IN+ - IN-)..... $\pm 2V$

Continuous Power Dissipation ($T_A = +70^\circ C$)
 16 QSOP (derate 8.3mW/ $^\circ C$ above $+70^\circ C$)667mW
 Operating Temperature Range-40 $^\circ C$ to +85 $^\circ C$
 Storage Temperature Range-55 $^\circ C$ to 150 $^\circ C$
 Lead Soldering Temperature (soldering, 10sec).....+300 $^\circ C$

DC ELECTRICAL CHARACTERISTICS

($V_{CC} = +3.0V$ to +3.6V, $T_A = 0^\circ C$ to +70 $^\circ C$, unless otherwise noted. Typical values are at $V_{CC} = +3.3V$ and $T_A = +25^\circ C$.)

PARAMETER	CONDITIONS	MIN	TYP	MAX	UNITS
Supply Current	MAX3750 (Note 1)		57	84	mA
	MAX3751 (Note 1)		54	78	
Data Input Voltage Swing	Total differential signal, peak-to-peak	200		2200	mV
Differential Input Impedance		132	150	172	Ω
Output Voltage at LOUT \pm and OUT \pm	150 Ω load, total differential signal, peak-to-peak	1000		1600	mV
TTL Input Current		-10		10	μA
TTL Input Low		-0.3		0.8	V
TTL Input High		2		$V_{CC} + 0.3$	V

Note 1: Output currents included.

AC ELECTRICAL CHARACTERISTICS

($V_{CC} = +3.0V$ to +3.6V, $T_A = 0^\circ C$ to +70 $^\circ C$, unless otherwise noted. Typical values are at $V_{CC} = +3.3V$ and $T_A = +25^\circ C$.)

PARAMETER	CONDITIONS	MIN	TYP	MAX	UNITS
Data Rate	MAX3750		2.125		Gbps
	MAX3751		1.0625		
Data Input Voltage Swing	Total differential signal, peak-to-peak	200		2200	mV
Output Edge Speed IN \pm \rightarrow OUT \pm , IN \pm \rightarrow LOUT \pm	MAX3750			160	ps
	MAX3751			325	
Deterministic Jitter IN \pm \rightarrow OUT \pm , IN \pm \rightarrow LOUT \pm , LIN \pm \rightarrow OUT \pm	MAX3750, peak-to-peak (Notes 2, 4)		10		ps
	MAX3751, peak-to-peak (Notes 3, 4)		10		
Random Jitter IN \pm \rightarrow OUT \pm , IN \pm \rightarrow LOUT \pm , LIN \pm \rightarrow OUT \pm	MAX3750, RMS (Note 2)			1.6	ps
	MAX3751, RMS (Note 3)			1.6	
Prop Delay IN \pm \rightarrow OUT \pm , IN \pm \rightarrow LOUT \pm , LIN \pm \rightarrow OUT \pm	MAX3750		300		ps
	MAX3751		442		

Note 2: Input t_R and $t_F < 150ps$, 20% to 80%.

Note 3: Input t_R and $t_F < 300ps$, 20% to 80%.

Note 4: Deterministic jitter is measured with 20 bits of the k28.5 pattern (00111110101100000101).

+3.3V, 2.125Gbps/1.0625Gbps Fibre Channel Port Bypass ICs

Typical Operating Characteristics

(VCC = 3.3V, TA = +25°C, unless otherwise noted.)

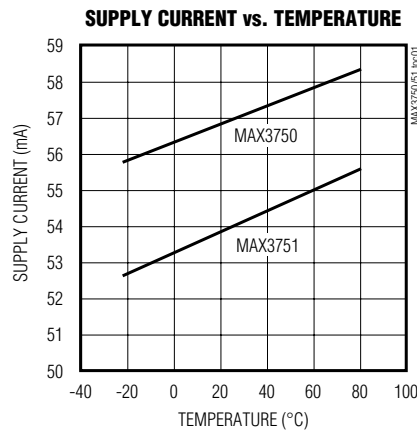

MAX3750/MAX3751

Pin Description

PIN	NAME	FUNCTION
1, 4, 5, 8, 16	GND	Electrical Ground
2	LOUT+	Noninverted Port Data Output
3	LOUT-	Inverted Port Data Output
6	OUT+	Noninverted Data Output
7	OUT-	Inverted Data Output
9	SEL	Select Input: SEL = Low: IN± → OUT± SEL = High: LIN± → OUT±
10	LIN-	Inverted Port Data Input
11	LIN+	Noninverted Port Data Input
12, 13	VCC	Positive Supply Voltage
14	IN-	Inverted Data Input
15	IN+	Noninverted Data Input

+3.3V, 2.125Gbps/1.0625Gbps Fibre Channel Port Bypass ICs

Circuit Description

A simplified block diagram of the single port bypass is shown in Figure 1. IN+ and IN- drive an input buffer (INBUFF) with 150Ω of internal differential input termination. INBUFF drives an output buffer (LOBUFF) and an input to a multiplexer (MUX).

A low TTL input at SEL selects the signal path of INBUFF through MUX to the output buffer (OUTBUFF). When SEL has a high TTL logic level present the signal path is into LIBUFF, through MUX, to OUTBUFF.

Low-Frequency Cutoff

The low-frequency cutoff is determined by the input resistance and the coupling capacitor as illustrated by the following equation:

$$f_c = 1 / (2\pi RC)$$

In a typical system where R = 150Ω and C = 100nF, resulting in f_c = 10kHz.

Layout Techniques

The MAX3750/MAX3751 are high-frequency products. The performance of the circuit is largely dependent upon layout of the circuit board. Use a multilayer circuit board with dedicated ground and V_{CC} planes. Power supplies should be capacitively bypassed to the ground plane with surface-mount capacitors placed near the power-supply pins.

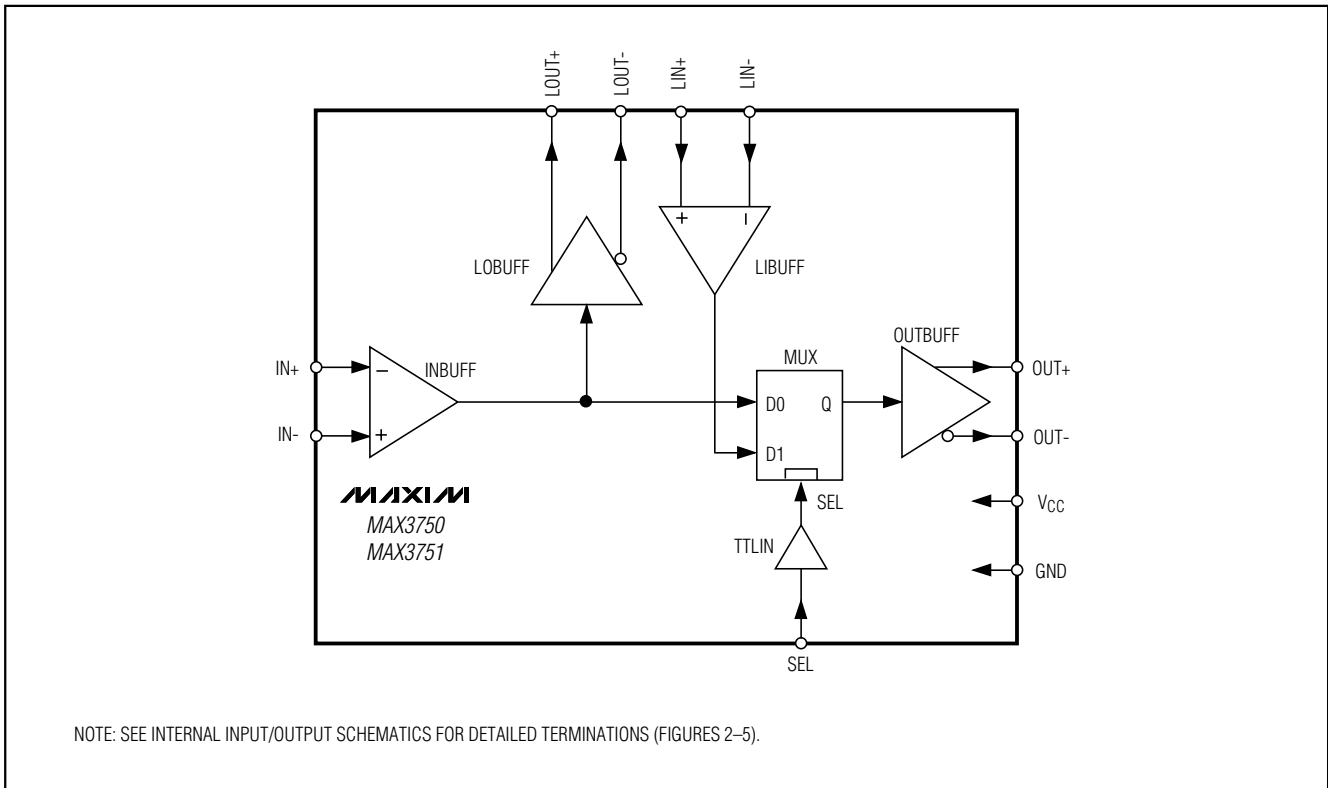

Figure 1. MAX3750/MAX3751 Block Diagram

+3.3V, 2.125Gbps/1.0625Gbps Fibre Channel Port Bypass ICs

MAX3750/MAX3751

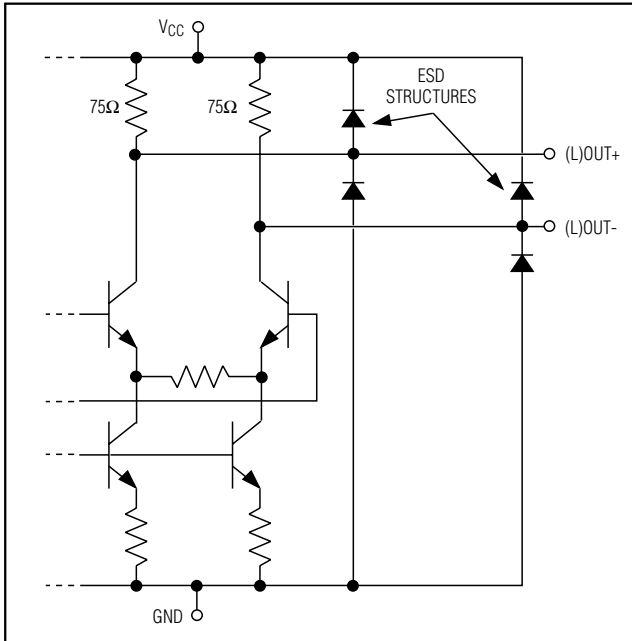

Figure 2. LOUT/OUT Pins Internal Input/Output Schematic

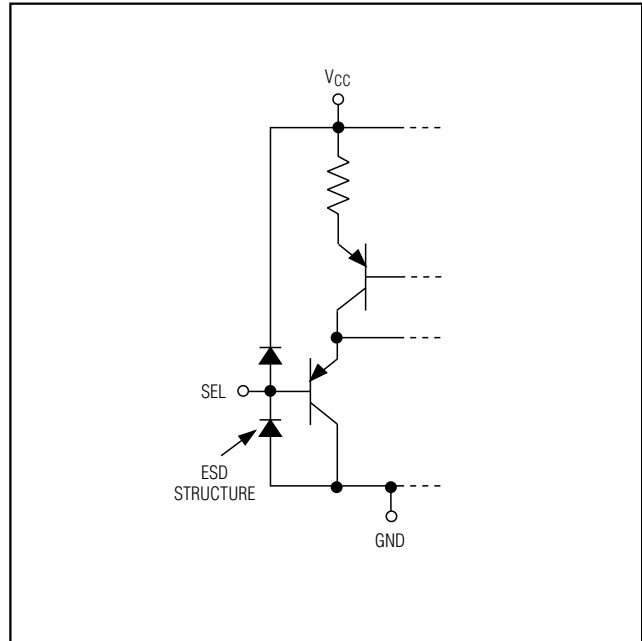

Figure 3. SEL Pin Internal Input/Output Schematic

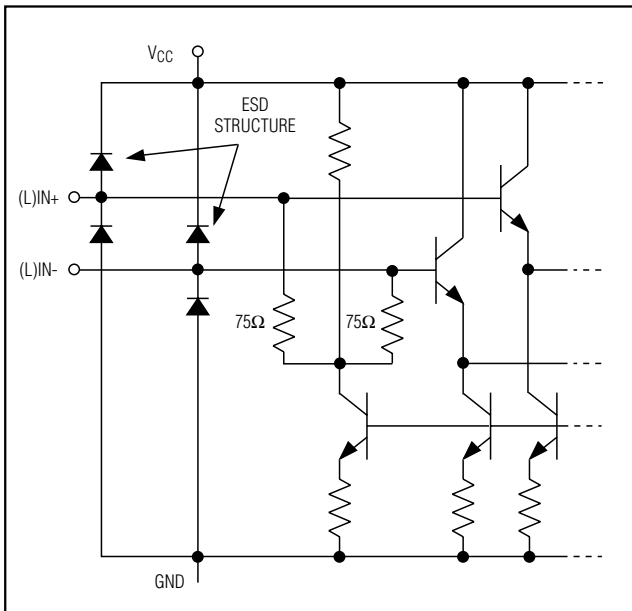

Figure 4. LIN/IN Pins Internal Input/Output Schematic

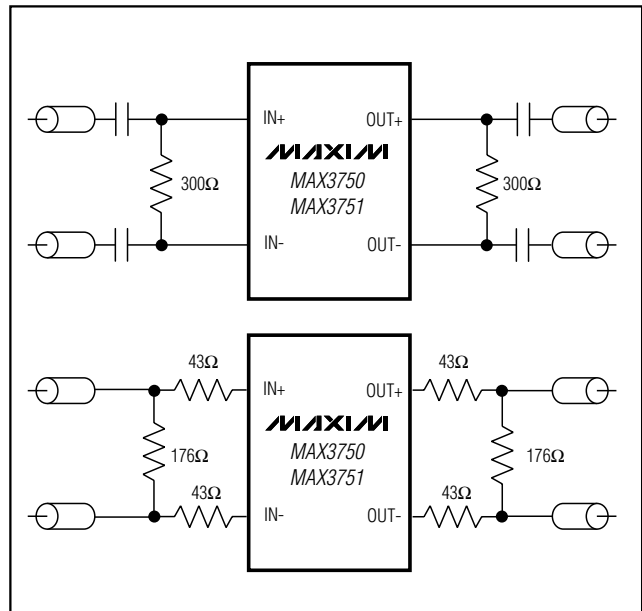
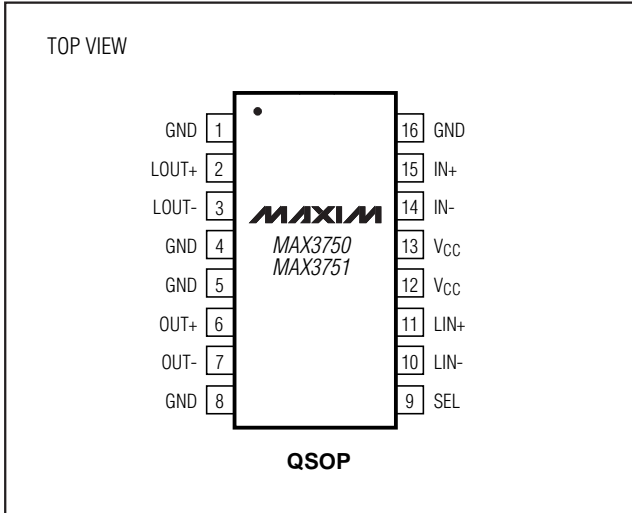

Figure 5. 50Ω Termination Applications

+3.3V, 2.125Gbps/1.0625Gbps Fibre Channel Port Bypass ICs

Pin Configuration



Package Information

DIM	INCHES		MILLIMETERS	
	MIN	MAX	MIN	MAX
A	.061	.068	1.55	1.73
A1	.004	.0098	0.102	0.249
A2	.055	.061	1.40	1.55
B	.008	.012	0.20	0.31
C	.0075	.0098	0.191	0.249
D	SEE VARIATIONS			
E	.150	.157	3.81	3.99
e	.025 BSC		0.635 BSC	
H	2.30	2.44	5.84	6.20
h	.010	.016	0.25	0.41
L	.016	.035	0.41	0.89
N	SEE VARIATIONS			
X	SEE VARIATIONS			
Y	.071	.087	1.803	2.209
α	0°	8°	0°	8°

VARIAIONS:

DIM	INCHES		MILLIMETERS		N
	MIN	MAX	MIN	MAX	
D	.189	.196	4.80	4.98	16/AA
S	.0020	.0070	0.05	0.18	
X	.107	.123	2.72	3.12	
D	.337	.344	8.56	8.74	20/AB
S	.0500	.0550	1.270	1.397	
D	.337	.344	8.56	8.74	24/AC
S	.0250	.0300	0.635	0.762	
D	.386	.393	9.80	9.98	28/AD
S	.0250	.0300	0.635	0.762	
X	.271	.287	6.88	7.29	

NOTES:
 1. D & E DO NOT INCLUDE MOLD FLASH OR PROTRUSIONS
 2. MOLD FLASH OR PROTRUSIONS NOT TO EXCEED .006" PER SIDE.
 3. HEAT SLUG DIMENSIONS X AND Y APPLY ONLY TO 16 AND 28 LEAD POWER-QSOP PACKAGES.
 4. CONTROLLING DIMENSIONS: INCHES.

MAXIM

PROPRIETARY INFORMATION

TITLE:
PACKAGE OUTLINE, QSOP, .150", .025" LEAD PITCH

APPROVAL	DOCUMENT CONTROL NO	REV	1/1
	21-0055	B	

Maxim cannot assume responsibility for use of any circuitry other than circuitry entirely embodied in a Maxim product. No circuit patent licenses are implied. Maxim reserves the right to change the circuitry and specifications without notice at any time.