

19-0107; Rev 3; 9/95



5A/2A Step-Down, PWM, Switch-Mode DC-DC Regulators

General Description

The MAX724/MAX726 are monolithic, bipolar, pulse-width modulation (PWM), switch-mode DC-DC regulators optimized for step-down applications. The MAX724 is rated at 5A, and the MAX726 at 2A. Few external components are needed for standard operation because the power switch, oscillator, and control circuitry are all on-chip. Employing a classic buck topology, these regulators perform high-current step-down functions, but can also be configured as inverters, negative boost converters, or flyback converters.

These regulators have excellent dynamic and transient response characteristics, while featuring cycle-by-cycle current limiting to protect against overcurrent faults and short-circuit output faults. The MAX724/MAX726 also have a wide 8V to 40V input range in the buck step-down configuration. In inverting and boost configurations, the input can be as low as 5V.

The MAX724/MAX726 are available in a 5-pin TO-220 package. The devices have a preset 100kHz oscillator frequency and a preset current limit of 6.5A (MAX724) or 2.6A (MAX726).

Applications

- Distributed Power from High-Voltage Buses
- High-Current, High-Voltage Step-Down Applications
- High-Current Inverter
- Negative Boost Converter
- Multiple-Output Buck Converter
- Isolated DC-DC Conversion

Typical Operating Circuit

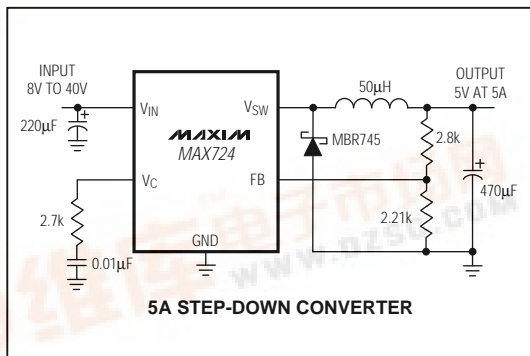

Features

- ◆ **Input Range: Up to 40V**
- ◆ **5A On-Chip Power Switch (MAX724)**
2A On-Chip Power Switch (MAX726)
- ◆ **Adjustable Output: 2.5V to 35V**
- ◆ **100kHz Switching Frequency**
- ◆ **Excellent Dynamic Characteristics**
- ◆ **Few External Components**
- ◆ **8.5mA Quiescent Current**
- ◆ **TO-220 Package**

Ordering Information

PART	TEMP. RANGE	PIN-PACKAGE
MAX724CCK	0°C to +70°C	5 TO-220
MAX724ECK	-40°C to +85°C	5 TO-220
MAX726CCK	0°C to +70°C	5 TO-220
MAX726ECK	-40°C to +85°C	5 TO-220

Pin Configuration

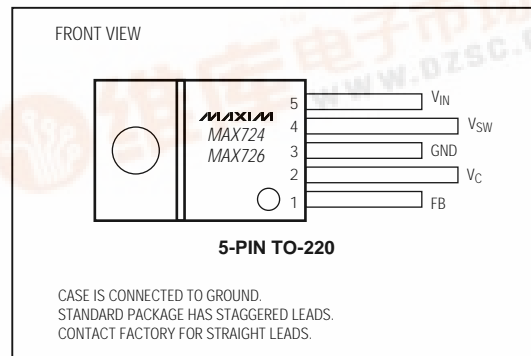

MAXIM

Maxim Integrated Products 1

Call toll free 1-800-998-8800 for free samples or literature.

MAX724/MAX726



5A/2A Step-Down, PWM, Switch-Mode DC-DC Regulators

ABSOLUTE MAXIMUM RATINGS

Input Voltage	45V	Junction Temperature Ranges	
Switch Voltage with Respect to Input Voltage	50V	MAX72_CCK	0°C to +125°C
Switch Voltage with Respect to Ground Pin (V_{SW} Negative)		MAX72_ECK	-40°C to +125°C
(Note 1)	35V	Storage Temperature Range	-65°C to +160°C
Feedback Pin Voltage	-0.3V, +10V	Lead Temperature (soldering, 10sec)	+300°C
Operating Temperature Ranges			
MAX72_CCK	0°C to +70°C		
MAX72_ECK	-40°C to +85°C		

Stresses beyond those listed under "Absolute Maximum Ratings" may cause permanent damage to the device. These are stress ratings only, and functional operation of the device at these or any other conditions beyond those indicated in the operational sections of the specifications is not implied. Exposure to absolute maximum rating conditions for extended periods may affect device reliability.

ELECTRICAL CHARACTERISTICS

($V_{IN} = 25V$, $T_J = T_{MIN}$ to T_{MAX} , unless otherwise noted.)

PARAMETER	CONDITIONS		MIN	TYP	MAX	UNITS	
Input Supply Voltage Range			8.0		40.0	V	
Switch-On Voltage (Note 2)	MAX724	$I_{SW} = 1A$	$T_J \geq 0^\circ C$		1.85	V	
			$T_J < 0^\circ C$		2.10		
		$I_{SW} = 5A$	$T_J \geq 0^\circ C$		2.30		
			$T_J < 0^\circ C$		2.50		
	MAX726	$I_{SW} = 0.5A$		1.2			
		$I_{SW} = 2A$		1.7			
Switch-Off Leakage	MAX724	$V_{IN} \leq 25V, V_{SW} = 0V$	$T_J = +25^\circ C$	5	300	μA	
		$V_{IN} = 40V, V_{SW} = 0V$	$T_J = +25^\circ C$	10	500		
	MAX726	$V_{IN} \leq 25V, V_{SW} = 0V$	$T_J = +25^\circ C$		150		
		$V_{IN} = 40V, V_{SW} = 0V$	$T_J = +25^\circ C$		250		
Supply Current (Note 3)	$V_{FB} = 2.5V, V_{IN} \leq 40V$			8.5	11	mA	
Minimum Supply Voltage	Normal Mode			7.3	8.0	V	
	Start-Up Mode (Note 4)	$T_J \geq 0^\circ C$		3.5	4.8	V	
		$T_J < 0^\circ C$		3.5	5.0		
Switch-Current Limit (Note 5)	MAX724		5.5	6.5	8.5	A	
	MAX726		2.0	2.6	3.2		
Maximum Duty Cycle			85	90		%	
Switching Frequency				90	100	110	kHz
				85	120		
	$V_{FB} = \text{grounded through } 2k\Omega \text{ (Note 5)}$		$T_J = +25^\circ C$		20		
Switching Frequency Line Regulation	$8V \leq V_{IN} \leq 40V$			0.03	0.1	%/V	

5A/2A Step-Down, PWM, Switch-Mode DC-DC Regulators

MAX724/MAX726

ELECTRICAL CHARACTERISTICS (continued)

($V_{IN} = 25V$, $T_J = T_{MIN}$ to T_{MAX} , unless otherwise noted.)

PARAMETER	CONDITIONS		MIN	TYP	MAX	UNITS
Error-Amplifier Voltage Gain	$1V \leq V_C \leq 4V$	$T_J = +25^\circ C$	2000			V/V
Error-Amplifier Transconductance		$T_J = +25^\circ C$	3000	5000	9000	μmho
Error-Amplifier Source Current	$V_{FB} = 2V$	$T_J = +25^\circ C$	100	140	225	μA
Error-Amplifier Sink Current	$V_{FB} = 2.5V$	$T_J = +25^\circ C$	0.6	1.0	1.7	mA
Feedback Pin Bias Current	$V_{FB} = V_{REF}$		0.5 2			μA
Reference Voltage	$V_C = 2V$		2.155	2.210	2.265	V
Reference Voltage Tolerance	V_{REF} (nominal) = 2.21V	$T_J = +25^\circ C$	$\pm 0.5 \pm 1.5$			%
	All conditions of input voltage, output voltage, temperature and load current		$\pm 1.0 \pm 2.5$			
Reference Voltage Line Regulation	$8V \leq V_{IN} \leq 40V$		0.005	0.02		%/V
VC Voltage at 0% Duty Cycle		$T_J = +25^\circ C$	1.5			V
		$T_J = T_{MIN}$ to T_{MAX}	-4			mV/ $^\circ C$
Thermal Resistance, Junction to Case (Note 6)	MAX724		2.5			$^\circ C/W$
	MAX726		4.0			

Note 1: Do not exceed switch-to-input voltage limitation.

Note 2: For switch currents between 1A and 5A (2A for MAX726), maximum switch-on voltage can be calculated via linear interpolation.

Note 3: By setting the feedback pin (FB) to 2.5V, the V_C pin is forced to its low clamp level and the switch duty cycle is forced to zero, approximating the zero load condition.

Note 4: For proper regulation, total voltage from V_{IN} to GND must be $\geq 8V$ after start-up.

Note 5: To avoid extremely short switch-on times, the switch frequency is internally scaled down when V_{FB} is less than 1.3V. Switch-current limit is tested with V_{FB} adjusted to give a 1 μs minimum switch-on time.

Note 6: Guaranteed, not production tested.

Typical Operating Characteristics

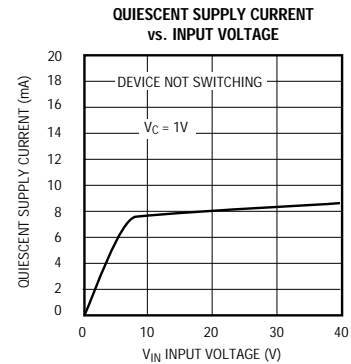
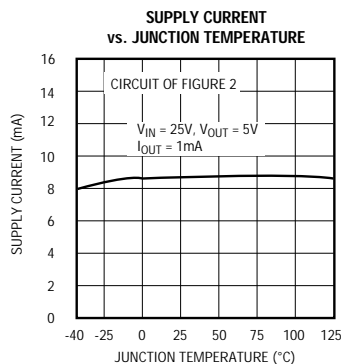
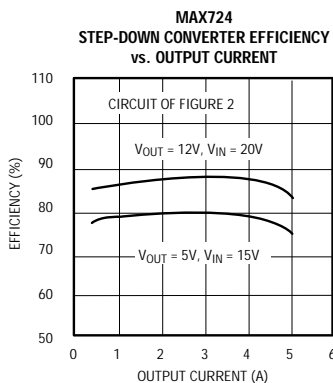

5A/2A Step-Down, PWM, Switch-Mode DC-DC Regulators

Typical Operating Characteristics (continued)

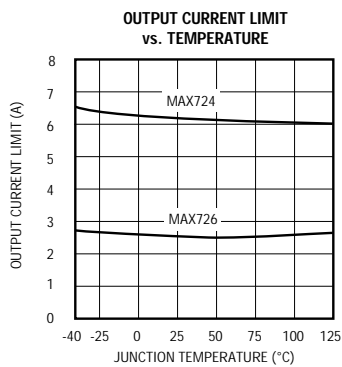
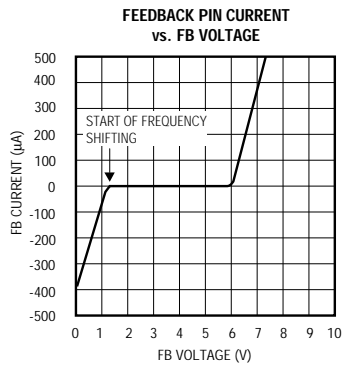
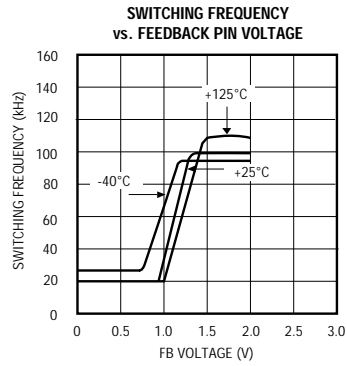
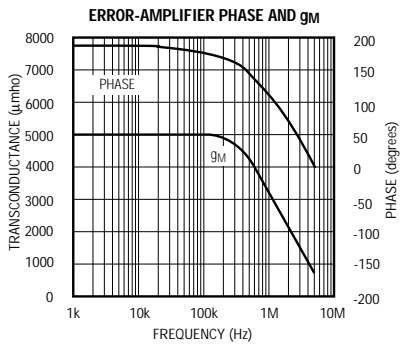
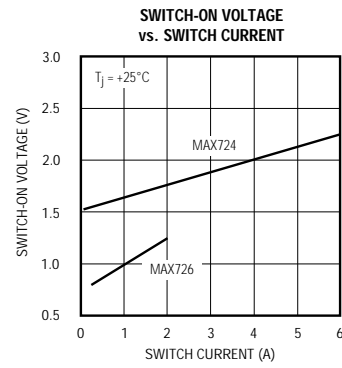
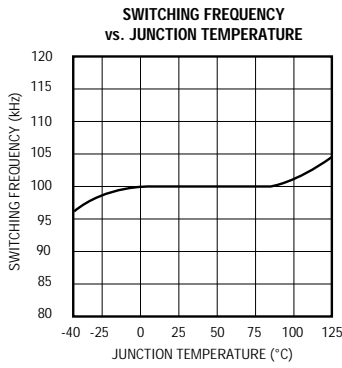
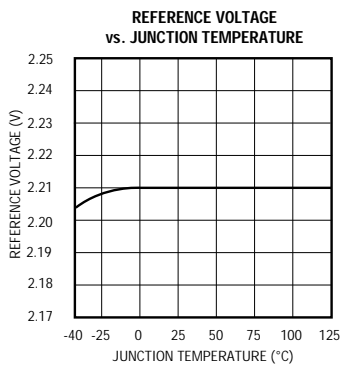

5A/2A Step-Down, PWM, Switch-Mode DC-DC Regulators

Pin Description

MAX724/MAX726

PIN	NAME	FUNCTION
1	FB	Feedback Input is the error amplifier's inverting input, and controls output voltage by adjusting switch duty cycle. Input bias current is typically 0.5μA when the error amplifier is balanced ($I_{OUT} = 0V$). FB also aids current limiting by reducing the oscillator frequency when the output voltage is low. (See the <i>Applications Information</i> section.)
2	V_C	Error-Amplifier Output. A series RC network connected to this pin compensates the MAX724/MAX726. Output swing is limited to about 5.8V in the positive direction and -0.7V in the negative direction. V_C can also synchronize the MAX724/MAX726 to an external clock. (See the <i>Applications Information</i> section).
3	GND	Ground requires a short low-noise connection to ensure good load regulation. The internal reference is referred to GND, so errors at this pin are multiplied by the error amplifier. See the <i>Applications Information</i> section for grounding details.
4	V_{SW}	Internal Power Switch Output. The switch output can swing 35V below ground and is rated for 5A (MAX724), 2A (MAX726).
5	V_{IN}	V_{IN} supplies power to the MAX724/MAX726's internal circuitry and also connects to the collector. V_{IN} must be bypassed with a low-ESR capacitor, typically 200μF or 220μF.

Detailed Description

The MAX724/MAX726 are complete, single-chip, pulse-width modulation (PWM), step-down DC-DC converters (Figure 1). All oscillator (100kHz), control, and current-limit circuitry, including a 5A power switch (2A for MAX726), are included on-chip. The oscillator turns on the switch (V_{SW}) at the beginning of each clock cycle. The switch turns off at a point later in the clock cycle, which is a function of the signal provided by the error amplifier. The maximum switch duty cycle is approximately 93% at the MAX724/MAX726's 100kHz switching frequency.

Both the input (FB) and output (V_C) of the error amplifier are brought out to simplify compensation. Most applications require only a single series RC network connected from V_C to ground. The error amplifier is a transconductance amplifier with a g_M of approximately 5000μmho. When slewing, V_C can source about 140μA, and sink about 1.1mA. This asymmetry helps minimize start-up overshoot by allowing the amplifier output to slew more quickly in the negative direction.

Current limiting is provided by the current-limit comparator. If the current-limit threshold is exceeded, the switch cycle terminates within about 600ns. The current-limit threshold is internally set to approximately

6.5A (2.6A for MAX726). V_{SW} is a power NPN, internally driven by the PWM controller circuitry. V_{SW} can swing 35V below ground and is rated for 5A (2A for MAX726).

Basic Step-Down Application

Figure 2 shows the MAX724/MAX726 in a basic step-down DC-DC converter. Typical MAX724 waveforms are shown in Figure 3 for $V_{IN} = 20V$, $V_{OUT} = 5V$, $L = 50μH$, and $I_{OUT} = 3A$ and 0.16A. Two sets of waveforms are shown. One set shows high load current (3A) where inductor current never falls to zero during the switch "off-cycle" (continuous-conduction mode, CCM). The second set of waveforms, at low output current (0.16A), shows inductor current at zero during the latter half of the switch off-cycle (discontinuous-conduction mode, DCM). The transition from CCM to DCM occurs at an output current (I_{DCM}) that can be derived with the following equation:

$$I_{DCM} = \frac{(V_{OUT} + V_D) [(V_{IN} - V_{SW}) - (V_{OUT} + V_D)]}{2 (V_{IN} - V_{SW}) f_{OSC} L}$$

where V_D is the diode forward voltage drop, V_{SW} is the voltage drop across the switch, and $f_{OSC} = 100kHz$. In most applications, the distinction between CCM and DCM is academic since actual performance differences are minimal. All CCM designs can be expected to exhibit DCM behavior at some level of reduced load current.

5A/2A Step-Down, PWM, Switch-Mode DC-DC Regulators

In DCM, ringing occurs at V_{SW} in the latter part of the switch off-cycle. This is due to the inductor resonating with the parallel capacitance of the catch diode and the V_{SW} node. This ringing is harmless and does not appear at the output. Furthermore, attempts to damp this ringing by adding circuitry will reduce efficiency and are not advised. No off-state ringing occurs in CCM because the diode always conducts during the switch-off time and consequently damps any resonance at V_{SW} .

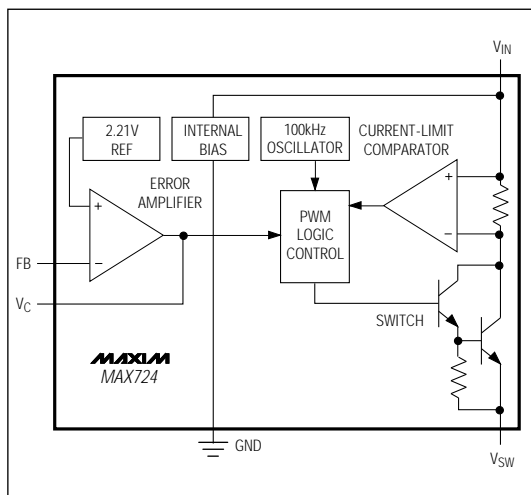

Figure 1. MAX724 Block Diagram

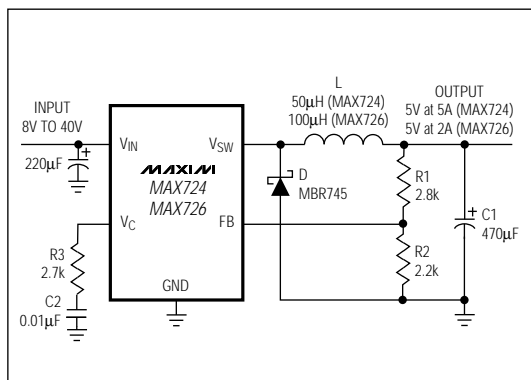

Figure 2. Basic Step-Down Converter

Component Selection

Table 1 lists component suppliers for inductors, capacitors, and diodes appropriate for use with the MAX724/MAX726. Be sure to observe specified ratings for all components.

Table 1. Component Suppliers

Surface-Mount Components (for designs typically below 2A)

Inductors:	Sumida Electric - CDR125 Series
	USA: Phone (708) 956-0666
	Japan: Phone 81-3607-5111 FAX 81-3607-5144
Coiltronics - CTX series	USA: Phone (305) 781-8900
	FAX (305) 782-4163
	Capacitors:
Matsuo - 267 series	USA: Phone (714) 969-2491
	FAX (714) 960-6492
	Japan: Phone 81-6337-6450
Sprague - 595D series	USA: Phone (603) 224-1961
	FAX (603) 224-1430
	Diodes:
USA: Phone (602) 244-5303	
FAX (602) 244-4015	
Nihon - NSQ series	USA: Phone (805) 867-2555
	FAX (805) 867-2556
	Japan: Phone 81-3-3494-7411 FAX 81-3-3494-7414

Through-Hole Components

Inductors:	Sumida - RCH-110 series
	(see above for phone number)
	Cadell-Burns - 7070, 7300, 6860, and 7200 series
USA:	Phone (516) 746-2310
	FAX (516) 742-2416
	Renco - various series
USA:	Phone (516) 586-5566
	FAX (516) 586-5562
	Coiltronics - various series
(see above for phone number)	Capacitors:
	Nichicon - PL series low-ESR electrolytics
	USA: Phone (708) 843-7500
FAX (708) 843-2798	Japan: Phone 81-7-5231-8461
	FAX 81-7-5256-4158
	United Chemi-Con - LXF series
USA:	Phone (714) 255-9500
	FAX (714) 255-9400
	Sanyo - OS-CON low-ESR organic semiconductor
USA:	Phone (619) 661-6835
	FAX (619) 661-1055
	Japan: Phone 81-7-2070-6306 FAX 81-7-2070-1174
Diodes:	General Purpose - 1N5820-1N5825
	Motorola - MBR and MBRD series
	(see above for phone number)

5A/2A Step-Down, PWM, Switch-Mode DC-DC Regulators

Inductor Selection

Although most MAX724 designs perform satisfactorily with 50 μ H inductors (100 μ H for the MAX726), the MAX724/MAX726 are able to operate with values ranging from 5 μ H to 200 μ H. In some cases, inductors other than 50 μ H may be desired to minimize size (lower inductance), or reduce ripple (higher inductance). In any case, inductor current must at least be rated for the desired output current.

In high-current applications, pay particular attention to both the RMS and peak inductor ratings. The inductor's peak current is limited by core saturation. Exceeding the saturation limit actually reduces the coil's inductance and energy storage ability, and increases power loss. Inductor RMS current ratings depend on heating effects in the coil windings.

The following equation calculates maximum output current as a function of inductance and input conditions:

$$I_{OUT} = I_{SW} \cdot \frac{V_{OUT} (V_{IN} - V_{OUT})}{2 f_{OSC} V_{IN} L}$$

where I_{SW} is the maximum switch current (5.5A for MAX724), V_{IN} is the maximum input voltage, V_{OUT} is the output voltage, and f_{OSC} is the switching frequency.

For the MAX724 example in Figure 2, with $L = 50\mu\text{H}$ and $V_{IN} = 25\text{V}$,

$$I_{OUT} = 5.5\text{A} \cdot \frac{5\text{V} (25\text{V} - 5\text{V})}{2 (10^5\text{Hz}) 25\text{V} (50 \times 10^{-6}\text{H})} = 5.1\text{A}$$

Note that increasing or decreasing inductor value provides only small changes in maximum output current (100 μ H = 5.3A, 20 μ H = 4.5A). The equation shows that output current is mostly a function of the MAX724/MAX726 current-limit value. Again, a 50 μ H inductor works well in most applications and provides 5A with a wide range of input voltages.

Catch Diode

D1 provides a path for inductor current when V_{SW} turns off. Under normal load conditions, the average diode current may only be a fraction of load current; but during short-circuit or current-limit, diode current is higher. Conservative design dictates that the diode average current rating be 2 times the desired output current. If operation with extended short-circuit or overload time is expected, then the diode current rating must exceed the current limit (6.5A = MAX724, 2.6A = MAX726), and heat sinking may be necessary.

Under normal operating conditions (not shorted), power dissipated in the diode P_D is calculated by:

$$P_D = I_{OUT} \frac{(V_{IN} - V_{OUT}) V_D}{V_{IN}}$$

where V_D is forward drop of the diode at a current equal to I_{OUT} . In nearly all circuits, Schottky diodes provide the best performance and are recommended due to their fast switching times and low forward voltage drop. Standard power rectifiers such as the 1N4000 series are too slow for DC-DC conversion circuits and are **not** recommended.

Output Filter Capacitor

For most MAX724/MAX726 applications, a high-quality, low-ESR, 470 μ F or 500 μ F output filter capacitor will suffice. To reduce ripple, minimize capacitor lead length and connect the capacitor directly to the GND pin. Capacitor suppliers are listed in Table 1. Output ripple is a function of inductor value and output capacitor effective series resistance (ESR). In continuous-conduction mode:

$$V_{CR(p-p)} = \frac{\text{ESR} (V_{OUT}) (1 - V_{OUT}/V_{IN})}{L f_{OSC}}$$

It is interesting to note that input voltage (V_{IN}), and not load current, affects output ripple in CCM. This is because only the DC, and not the peak-to-peak, inductor current changes with load (see Figure 3).

In discontinuous-conduction mode, the equation is different because the peak-to-peak inductor current does depend on load:

$$V_{DR(p-p)} = \text{ESR} \sqrt{\frac{2 I_{OUT} V_{OUT} (V_{IN} - V_{OUT})}{L f_{OSC} V_{IN}}}$$

where output ripple is proportional to the square root of load current. Refer to the earlier equation for I_{DCM} to determine where DCM occurs and hence when the DCM ripple equation should be used.

Input Bypass Capacitor

An input capacitor (200 μ F or 220 μ F) is required for step-down converters because the input current, rather than being continuous (like output current), is a square wave. For this reason the capacitor must have low ESR and a ripple-current rating sufficiently large so that its ESR and the AC input current do not conspire to overheat the capacitor. In CCM, the capacitor's RMS ripple current is:

$$I_{R(RMS)} = I_{OUT} \sqrt{\frac{V_{OUT} (V_{IN} - V_{OUT})}{V_{IN}^2}}$$

The power dissipated in the input capacitor is then P_C :

$$P_C = I_{R(RMS)}^2 (\text{ESR})$$

5A/2A Step-Down, PWM, Switch-Mode DC-DC Regulators

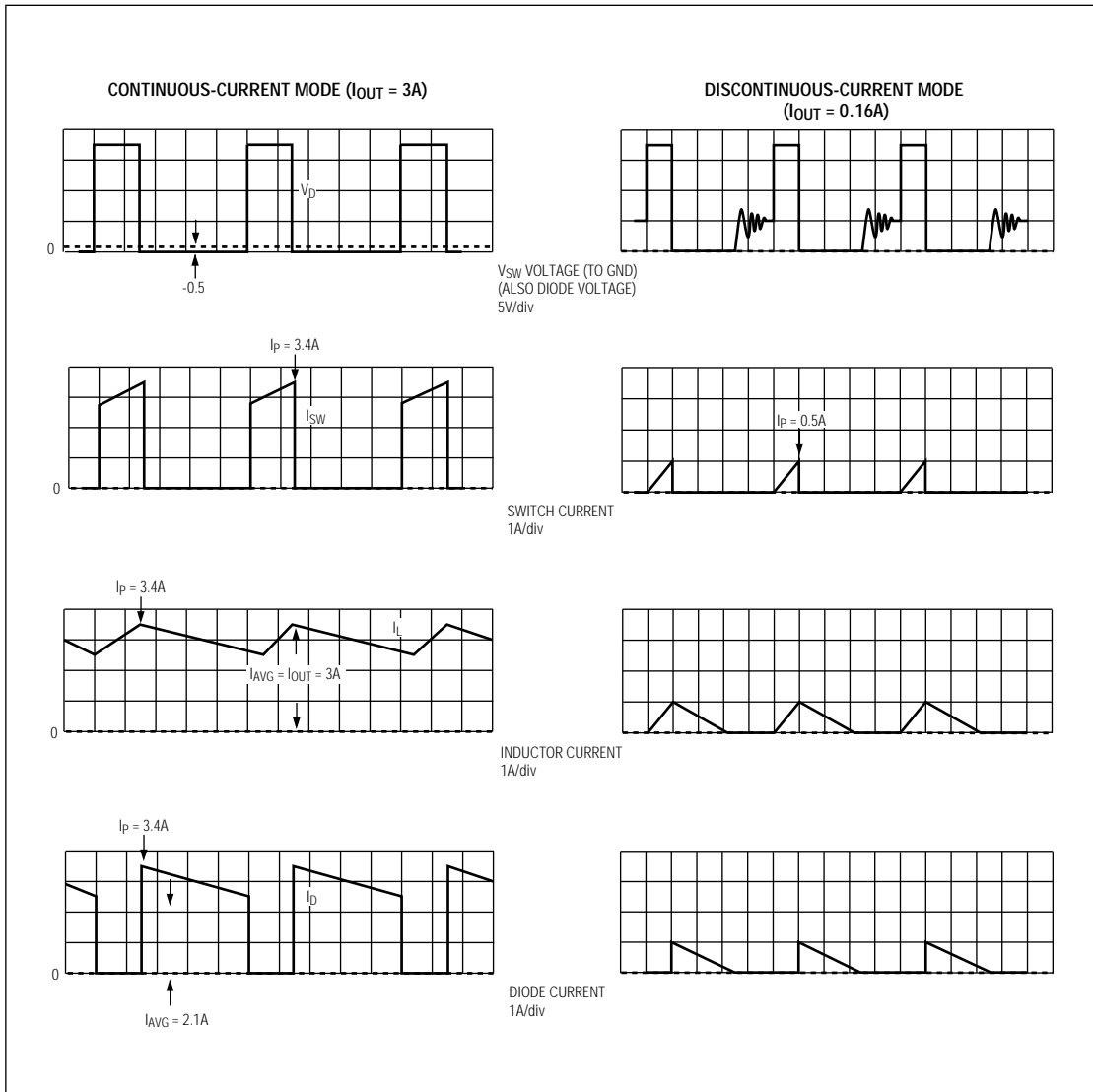

Figure 3. MAX724 Step-Down Converter Waveforms with $V_{IN} = 20V$, $L = 50\mu H$ (all waveforms $2\mu s/div$)

5A/2A Step-Down, PWM, Switch-Mode DC-DC Regulators

Be sure that the selected capacitor can handle the ripple current over the required temperature range. Also locate the input capacitor very close to the MAX724/MAX726 and use minimum length leads (surface-mount or radial through-hole types). In most applications, ESR is more important than actual capacitance value since electrolytic capacitors are mostly resistive at the MAX724/MAX726's 100kHz switching frequency.

Applications Information

Setting Output Voltage

R1 and R2 set output voltage as follows:

$$R1 = \frac{V_{OUT} R2}{2.21V} - R2$$

2.21V is the reference voltage, so setting R2 to 2.21k Ω (standard 1% resistor value) results in 1mA flowing through R1 and R2 and simplifies the above equation. Other values will also work for R2, but should not exceed 4k Ω .

Synchronizing the Oscillator

The MAX724/MAX726 can be synchronized to an external 110kHz to 160kHz source by pulsing the V_C pin to ground at the desired clock rate. This is conveniently done with the collector of an external grounded-emitter NPN transistor. V_C should be pulled low for 300ns. Doing this may have some impact on output regulation, but the effect should be minimal for compensation resistor values between 1k Ω and 4k Ω .

Power Dissipation

The MAX724/MAX726 draw about 7.5mA operating current, which is largely independent of input voltage or load current. They draw an additional 5mA during switch on-time. Power dissipated in the internal V_{SW} transistor is proportional to load current and depends on both conduction losses (product of switch on-voltage and switch current) and dynamic switching losses (due to switch rise and fall times). Total MAX724 power dissipation can be calculated as follows:

$$P = V_{IN} [7.5mA + 5mA (DC) + 2 I_{OUT} t_{SW} f_{osc}] + \dots$$

$$\dots DC [I_{OUT} (1.8V) + 0.1\Omega (I_{OUT})^2]$$

$$DC = \text{Duty Cycle} = \frac{V_{OUT} + 0.5V}{V_{IN} - 2V}$$

$$t_{SW} = \text{Overlap Time} = 50ns + (3ns/A) I_{OUT}$$

where t_{SW} is "overlap" time. Switch dissipation is momentarily high during overlap time because both cur-

rent and voltage appear across the switch at the same time. t_{SW} is approximately: [50ns + (3ns/A) (I_{OUT})] for the MAX724.

Power dissipation in the MAX726 can be estimated in exactly the same way as the MAX724, except that 1.1V (and not 1.8V) is a more reasonable value for the nominal voltage drop across the on-board power switch.

Ground Connections

GND demands a short low-noise connection to ensure good load regulation. Since the internal reference is referred to GND, errors in the GND pin voltage get multiplied by the error amplifier and appear at the output. If the MAX724/MAX726 GND pin is separated from the negative side of the load, then high load return current can generate significant error across a seemingly small ground resistance. Single-point grounding is the most effective way to eliminate these errors. A recommended ground arrangement is shown in Figure 4.

Overload Protection

The V_{SW} current is internally limited to about 6.5A in the MAX724 and 2.6A in the MAX726. In addition, another feature of the MAX724/MAX726's overload protection scheme is that the oscillator frequency is reduced when the output voltage falls below approximately half its regulated value. This is the case during short-circuit and heavy overload conditions.

Since the minimum on-time for the switch is about 0.6 μ s, frequency reduction during overload ensures that switch duty cycle can fall to a low enough value to maintain control of output current. At the normal 100kHz switching frequency, an on-time as short as

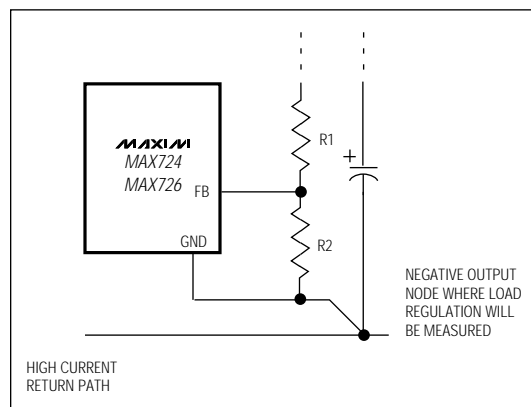

Figure 4. Recommended Ground Connection

5A/2A Step-Down, PWM, Switch-Mode DC-DC Regulators

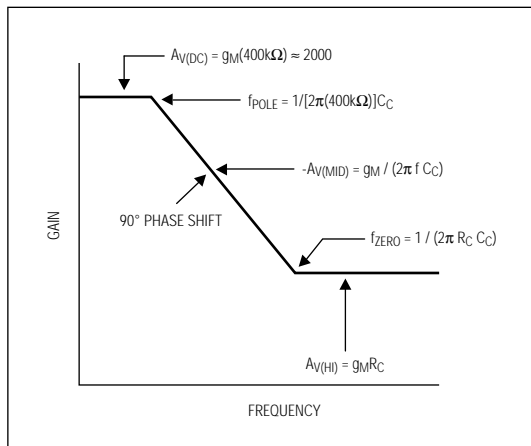

Figure 5. Error-Amplifier Gain as Set by R_C and C_C at V_C Pin

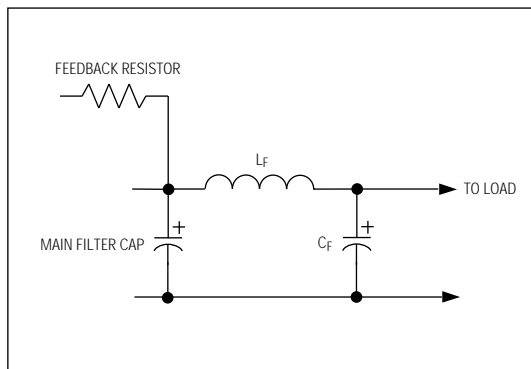

Figure 6. Optional LC Output Filter

$0.2\mu\text{s}$ would be needed to provide a narrow enough duty cycle that could control current when the output is shorted. Since $0.6\mu\text{s}$ is too long (at 100kHz), the f_{OSC} is lowered to 20kHz once FB (and hence the output) drops below about 1.3V (see Frequency vs. V_{FB} Voltage graph in the *Typical Operating Characteristics*). This way, the MAX724/MAX726's $0.6\mu\text{s}$ minimum t_{ON} allows a sufficiently small duty cycle (at the reduced f_{OSC}) so that current can still be limited.

Compensation Network

A series RC network connected from V_C to ground compensates the MAX724/MAX726. Compensation R_C values are shown in the applications circuits. R_C and C_C shape error-amplifier gain as follows: At DC, R_C and C_C have no effect, so the error-amplifier's gain is the product of its transconductance (approximately $5000\mu\text{mhos}$) and an internal $400\text{k}\Omega$ load impedance (r_{INT}) at V_C . So at DC, $A_{V(\text{DC})} = g_M(r_{\text{INT}}) =$ approximately $2000\mu\text{mhos}$. R_C and C_C then add a low-frequency pole and a high-frequency zero, as shown in Figure 5.

Output Overshoot

The MAX724/MAX726 error-amplifier design minimizes overshoot, but precautions against overshoot should still be exercised in sensitive applications. Worst-case overshoot typically occurs when recovering from an output short because V_C slews down from its highest voltage. This can be checked by simply shorting and releasing the output.

Reduce objectional overshoot by increasing the compensation resistor (to $3\text{k}\Omega$ or $4\text{k}\Omega$) at V_C . This allows the error-amplifier output, V_C , to move more rapidly in the negative direction. In some cases, loop stability may suffer with a high-value compensation resistor. An option, then, is to add output filter capacitance, which reduces short-circuit recovery overshoot by limiting output rise time. Lowering the compensation capacitor to below $0.05\mu\text{F}$ may also help by allowing V_C to slew further before the output rises too far.

Optional Output Filters

Though not shown in the application circuits in Figures 2, 7, and 8, additional filtering can easily be added to reduce output ripple to levels below 2%. It is more effective to add an LC type filter rather than additional output capacitance alone. A small-value inductor ($2\mu\text{H}$ to $10\mu\text{H}$) and between $47\mu\text{F}$ and $220\mu\text{F}$ of filter capacitance should suffice (Figure 6). Although the inductor does not need to be of high quality (it is not switching), it must still be rated for the full load current.

When an LC filter is added, do not move the connection of the feedback resistor to the LC output. It should be left connected to the main output filter capacitor (C_1 in Figure 2). If the feedback connection is moved to the LC filter point, the added phase shift may impact stability.

5A/2A Step-Down, PWM, Switch-Mode DC-DC Regulators

Typical Applications

Positive-to-Negative DC-DC Inverter

The MAX724/MAX726 can convert positive input voltages to negative outputs if the sum of input and output voltage is greater than 8V, and the minimum positive supply is 4.5V. The connection in Figure 7 shows the MAX724 generating -5V. The device's GND pin is connected to the negative output, which allows the feedback divider, R3, and R4 to be connected normally. If the GND pin were tied to circuit ground, a level shift and inversion would be required to generate the proper feedback signal.

Component values in Figure 8 are shown for input voltages up to 35V and for a 1A output. If the maximum input voltage is lower, a Schottky diode with lower reverse breakdown than the MBR745 (D1) may be used. If lower output current is needed, then the current rating of both D1 and L1 may be reduced. In addition, if the minimum input voltage is higher than 4.5V, then greater output current can be supplied.

R1, R2, and C4 provide compensation for low input voltages, but R1 and R2 also figure in the output-voltage calculation because they are effectively connected in parallel with R3. For larger negative outputs, increase R1, R2, and R3 proportionally while maintain-

ing the following relationships. If V_{IN} does not fall below $2V_{OUT}$, then R1, R2, and C4 can be omitted and only R3 and R4 set the output voltage.

$$\begin{aligned} R4 &= 1.82k\Omega \\ R3 &= |V_{OUT}| - 2.37 \text{ (in } k\Omega) \\ R1 &= 1.86 (R3) \\ R2 &= 3.65 (R3) \end{aligned}$$

Negative Boost DC-DC Converter

The MAX724/MAX726 can also work as a negative boost converter (Figure 8) by tying the GND pin to the negative output. This allows the regulator to operate from input voltages as low as -4.5V. If the regulated output is at least -8V, R1 and R2 set the output voltage as in a conventional connection, with R1 selected from:

$$R1 = \frac{V_{OUT} R2}{2.21} - R2$$

L1 must be a low value to maintain stability, but if V_{IN} is greater than -10V, L1 can be increased to 50 μ H. Since this is a boost configuration, if the input voltage exceeds the output voltage, D1 will pull the output more negative and out of regulation. Also, if the output is pulled toward ground, D1 will drag down the input supply. For this reason, this configuration is not short-circuit protected.

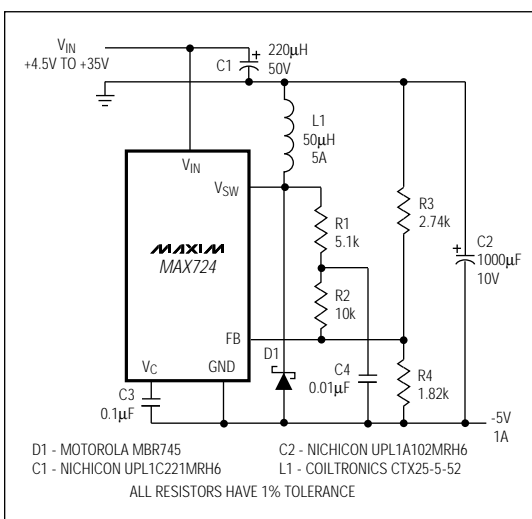

Figure 7. Positive-to-Negative DC-DC Inverter

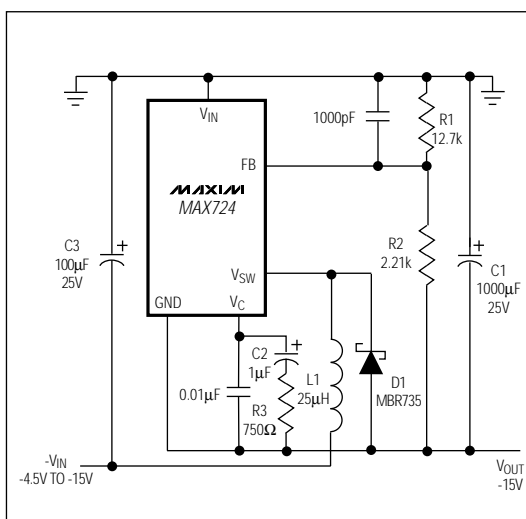

Figure 8. Negative Step-Up DC-DC Converter

5A/2A Step-Down, PWM, Switch-Mode DC-DC Regulators

Package Information

DIM	INCHES		MILLIMETERS	
	MIN	MAX	MIN	MAX
A	0.140	0.190	3.56	4.82
B	0.015	0.040	0.38	1.01
C1	0.014	0.022	0.41	0.50
D	0.560	0.650	14.23	16.51
E	0.380	0.420	9.66	10.66
e	0.067 BSC		1.70 BSC	
F	0.045	0.055	1.14	1.39
H1	0.230	0.270	5.85	6.85
J1	0.080	0.115	2.04	2.92
J2	0.170	0.185	4.32	4.70
J3	0.327	0.335	8.31	8.51
L	0.170	0.200	4.32	5.08
L1	0.260	0.340	6.60	8.64
L2	0.700	0.720	17.78	18.29
φP	0.139	0.161	3.54	4.08
Q	0.100	0.120	2.54	3.04

21-005-

5-PIN TO-220 (STAGGERED LEAD) PACKAGE

DIM	INCHES		MILLIMETERS	
	MIN	MAX	MIN	MAX
A	0.140	0.190	3.56	4.82
B	0.015	0.040	0.38	1.01
C1	0.014	0.022	0.41	0.50
D	0.560	0.650	14.23	16.51
E	0.380	0.420	9.66	10.66
e	0.067 BSC		1.70 BSC	
F	0.045	0.055	1.14	1.39
H1	0.230	0.270	5.85	6.85
J1	0.080	0.115	2.04	2.92
L	0.500	0.580	12.70	14.73
φP	0.139	0.161	3.54	4.08
Q	0.100	0.120	2.54	3.04

21-4737-

5-PIN TO-220 (STRAIGHT LEAD) PACKAGE

CONTACT FACTORY FOR AVAILABILITY

Maxim cannot assume responsibility for use of any circuitry other than circuitry entirely embodied in a Maxim product. No circuit patent licenses are implied. Maxim reserves the right to change the circuitry and specifications without notice at any time.

12 Maxim Integrated Products, 120 San Gabriel Drive, Sunnyvale, CA 94086 (408) 737-7600