

# MAX828, MAX829

## Switched Capacitor Voltage Converter

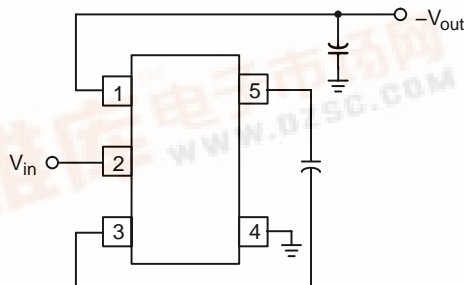
The MAX828 and MAX829 are CMOS charge pump voltage inverters that are designed for operation over an input voltage range of 1.15 V to 5.5 V with an output current capability in excess of 50 mA. The operating current consumption is only 68  $\mu$ A for the MAX828 and 118  $\mu$ A for the MAX829. The devices contain an internal oscillator that operates at 12 kHz for the MAX828 and 35 kHz for the MAX829. The oscillator drives four low resistance MOSFET switches, yielding a low output resistance of 26  $\Omega$  and a voltage conversion efficiency of 99.9%. These devices require only two external capacitors, 10  $\mu$ F for the MAX828 and 3.3  $\mu$ F for the MAX829, for a complete inverter making it an ideal solution for numerous battery powered and board level applications. The MAX828 and MAX829 are available in the space saving Thin SOT-23-5 package.

### Features

- Pb-Free Packages are Available
- Operating Voltage Range of 1.15 V to 5.5 V
- Output Current Capability in Excess of 50 mA
- Low Current Consumption of 68  $\mu$ A (MAX828) or 118  $\mu$ A (MAX829)
- Operation at 12 kHz (MAX828) or 35 kHz (MAX829)
- Low Output Resistance of 26  $\Omega$
- Space Saving Thin SOT-23-5 Package

### Typical Applications

- LCD Panel Bias
- Cellular Telephones
- Pagers
- Personal Digital Assistants
- Electronic Games
- Digital Cameras
- Camcorders
- Hand-Held Instruments



This device contains 77 active transistors.

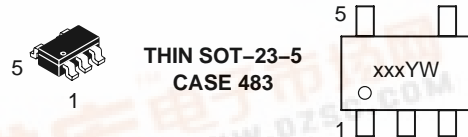
Figure 1. Typical Application



ON Semiconductor®

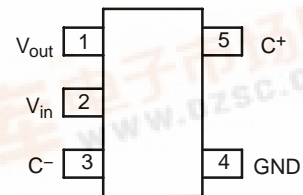
<http://onsemi.com>

### MARKING DIAGRAM



xxx = Device Code  
 MAX828 = EAA  
 MAX829 = EAB  
 Y = Year  
 W = Work Week

### PIN CONFIGURATION



Thin SOT-23-5\*  
(Top View)

### ORDERING INFORMATION

Device	Package	Shipping†
MAX828EUK	Thin SOT-23-5	3000 Tape/Reel
MAX828EUKG	Thin SOT-23-5 (Pb-Free)	3000 Tape/Reel
MAX829EUK	Thin SOT-23-5	3000 Tape/Reel
MAX829EUKG	Thin SOT-23-5 (Pb-Free)	3000 Tape/Reel

†For information on tape and reel specifications, including part orientation and tape sizes, please refer to our Tape and Reel Packaging Specifications Brochure, BRD8011/D.



## MAX828, MAX829

### MAXIMUM RATINGS\*

Rating	Symbol	Value	Unit
Input Voltage Range ( $V_{in}$ to GND)	$V_{in}$	-0.3 to 6.0	V
Output Voltage Range ( $V_{out}$ to GND)	$V_{out}$	-6.0 to 0.3	V
Output Current (Note 1)	$I_{out}$	100	mA
Output Short Circuit Duration ( $V_{out}$ to GND, Note 1)	$t_{SC}$	Indefinite	sec
Operating Junction Temperature	$T_J$	150	°C
Power Dissipation and Thermal Characteristics Thermal Resistance, Junction to Air Maximum Power Dissipation @ $T_A = 70^\circ\text{C}$	$R_{\theta JA}$ $P_D$	256 313	°C/W mW
Storage Temperature	$T_{stg}$	-55 to 150	°C

Maximum ratings are those values beyond which device damage can occur. Maximum ratings applied to the device are individual stress limit values (not normal operating conditions) and are not valid simultaneously. If these limits are exceeded, device functional operation is not implied, damage may occur and reliability may be affected.

#### \*ESD Ratings

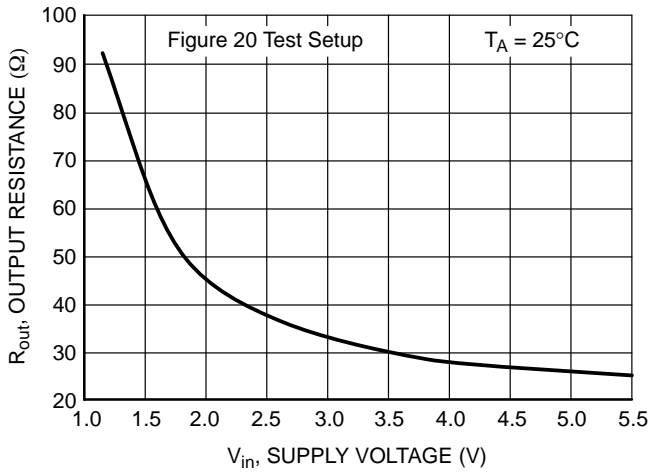
ESD Machine Model Protection up to 200 V, Class B  
ESD Human Body Model Protection up to 2000 V, Class 2

**ELECTRICAL CHARACTERISTICS** ( $V_{in} = 5.0$  V for MAX828  $C_1 = C_2 = 10$   $\mu\text{F}$ , for MAX829  $C_1 = C_2 = 3.3$   $\mu\text{F}$ ,  $T_A = -40^\circ\text{C}$  to  $85^\circ\text{C}$ , typical values shown are for  $T_A = 25^\circ\text{C}$  unless otherwise noted. See Figure 20 for test setup.)

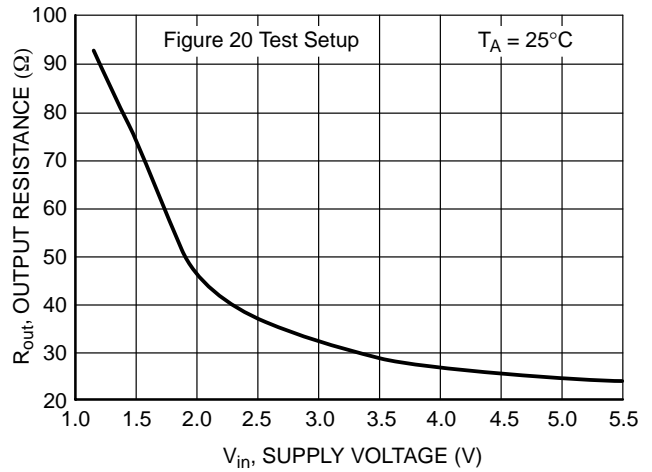
Characteristic	Symbol	Min	Typ	Max	Unit
Operating Supply Voltage Range ( $R_L = 10$ k)	$V_{in}$	1.5 to 5.5	1.15 to 6.0	-	V
Supply Current Device Operating ( $R_L = \infty$ ) $T_A = 25^\circ\text{C}$ MAX828 MAX829 $T_A = 85^\circ\text{C}$ MAX828 MAX829	$I_{in}$	- - - -	68 118 73 128	90 200 100 200	$\mu\text{A}$
Oscillator Frequency $T_A = 25^\circ\text{C}$ MAX828 MAX829 $T_A = -40^\circ\text{C}$ to $85^\circ\text{C}$ MAX828 MAX829	$f_{OSC}$	8.4 24.5 6.0 19	12 35 - -	15.6 45.6 21 54	kHz
Output Resistance ( $I_{out} = 25$ mA, Note 2) MAX828 MAX829	$R_{out}$	- -	26 26	50 50	$\Omega$
Voltage Conversion Efficiency ( $R_L = \infty$ )	$V_{EFF}$	99	99.9	-	%
Power Conversion Efficiency ( $R_L = 1.0$ k)	$P_{EFF}$	-	96	-	%

- Maximum Package power dissipation limits must be observed to ensure that the maximum junction temperature is not exceeded.  
 $T_J = T_A + (P_D R_{\theta JA})$
- Capacitors  $C_1$  and  $C_2$  contribution is approximately 20% of the total output resistance.

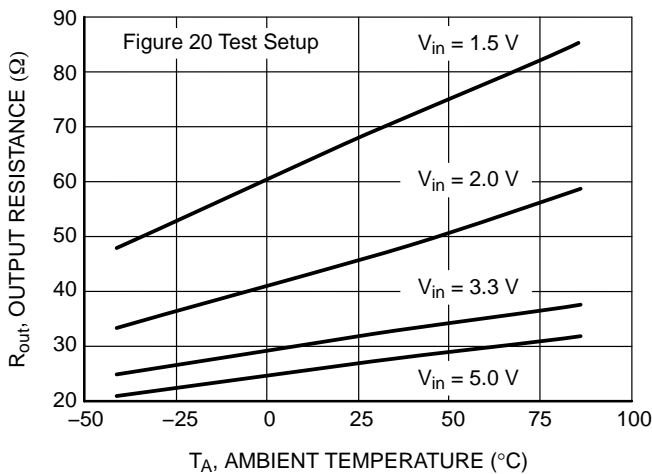
# MAX828, MAX829



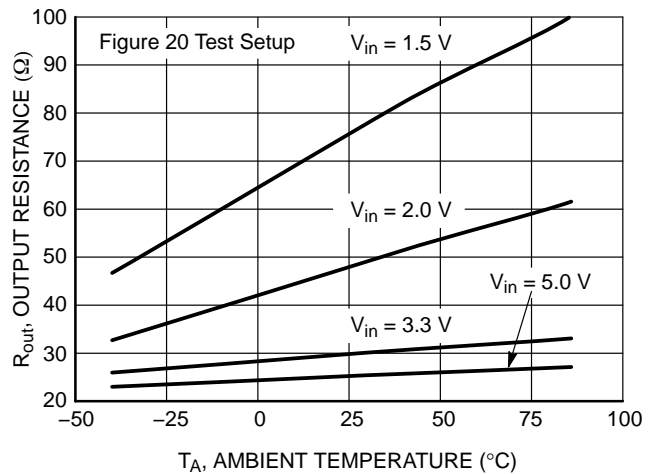
**Figure 2. Output Resistance vs. Supply Voltage MAX828**



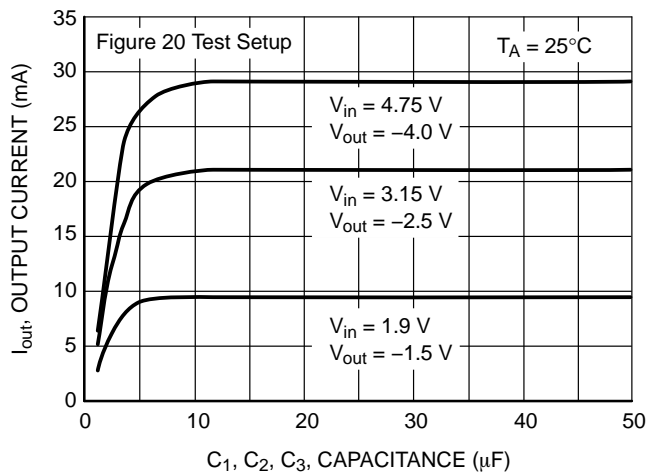
**Figure 3. Output Resistance vs. Supply Voltage MAX829**



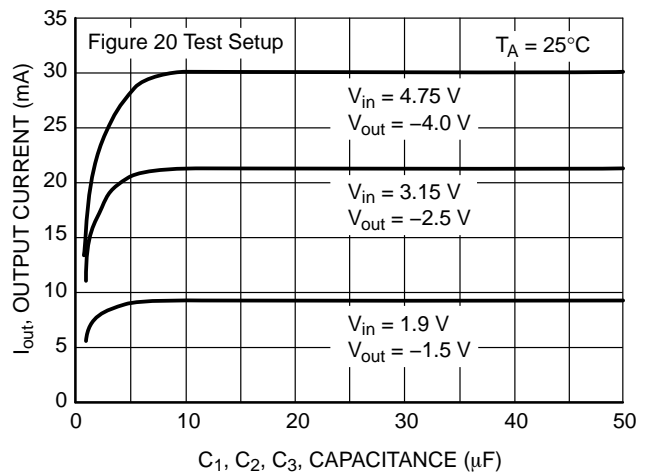
**Figure 4. Output Resistance vs. Ambient Temperature MAX828**



**Figure 5. Output Resistance vs. Ambient Temperature MAX829**

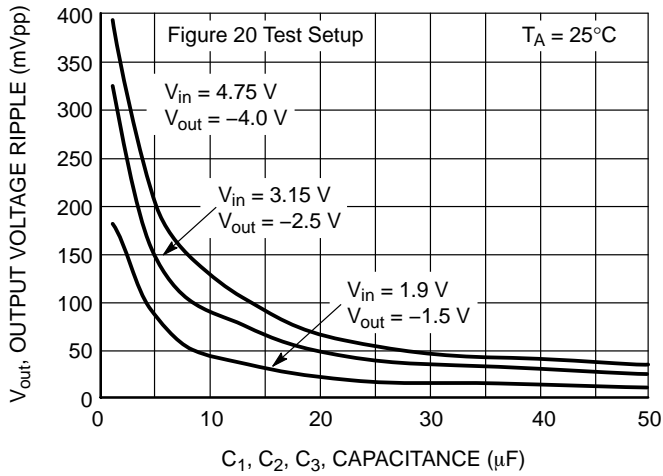


**Figure 6. Output Current vs. Capacitance MAX828**

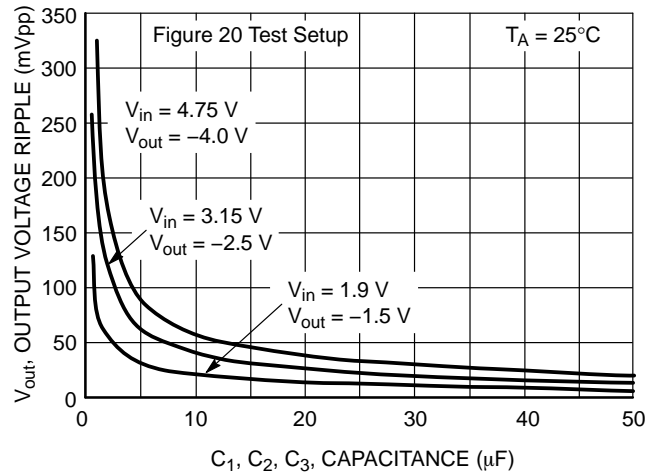


**Figure 7. Output Current vs. Capacitance MAX829**

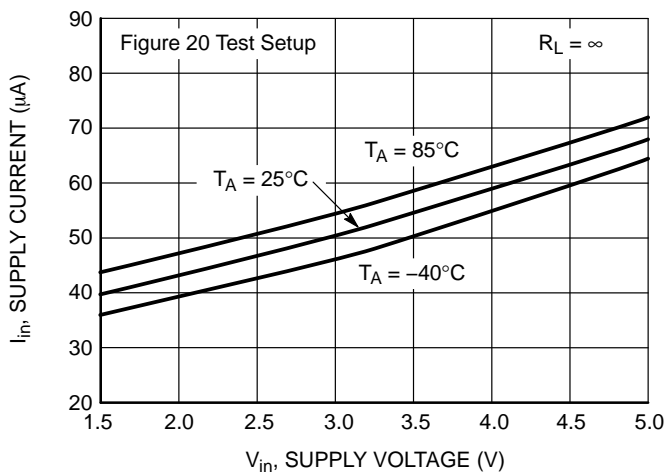
## MAX828, MAX829



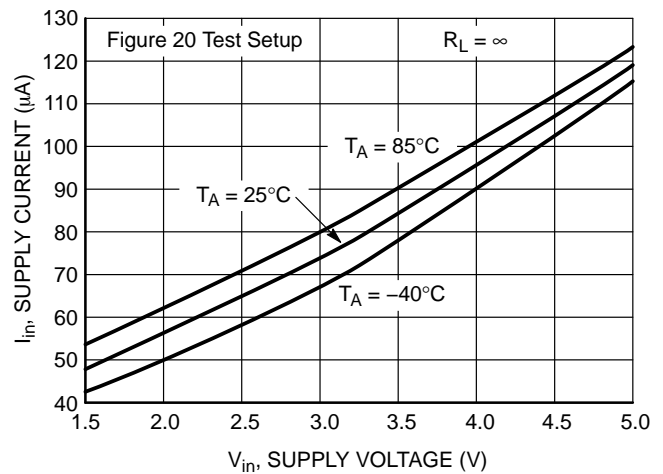
**Figure 8. Output Voltage Ripple vs. Capacitance MAX828**



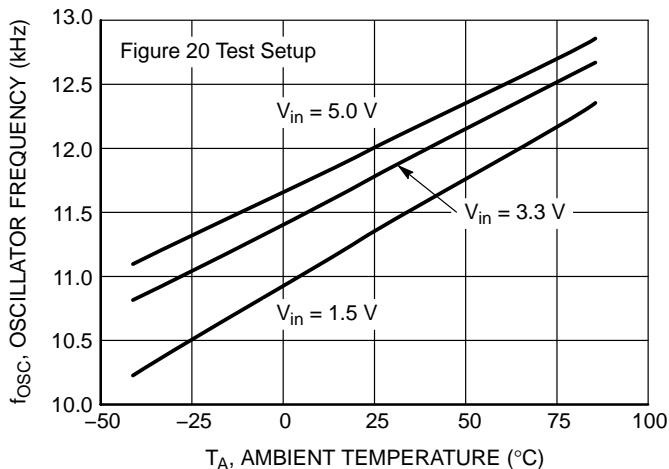
**Figure 9. Output Voltage Ripple vs. Capacitance MAX829**



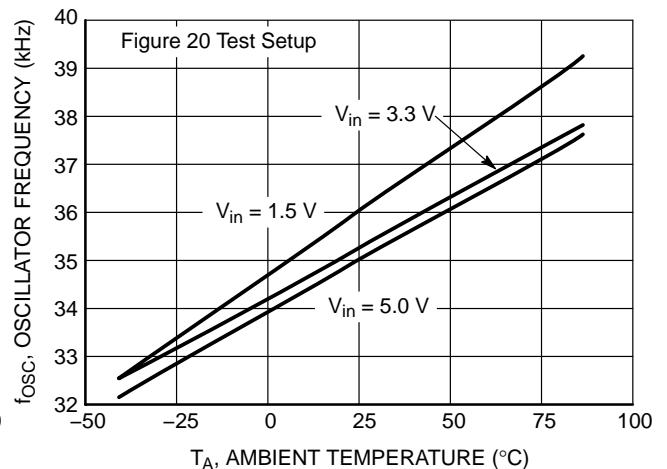
**Figure 10. Supply Current vs. Supply Voltage MAX828**



**Figure 11. Supply Current vs. Supply Voltage MAX829**

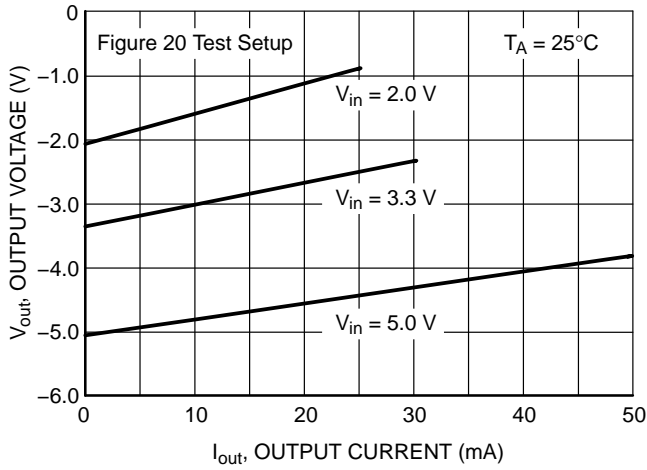


**Figure 12. Oscillator Frequency vs. Ambient Temperature MAX828**

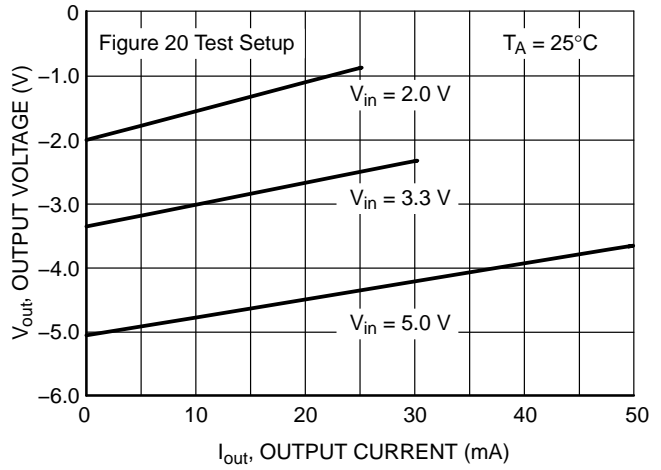


**Figure 13. Oscillator Frequency vs. Ambient Temperature MAX829**

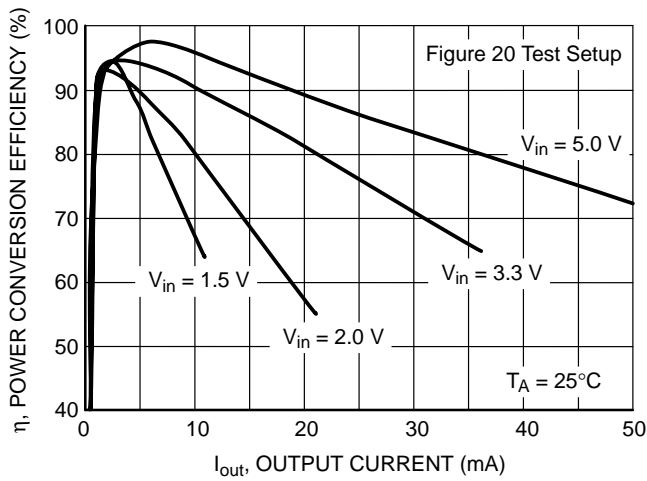
# MAX828, MAX829



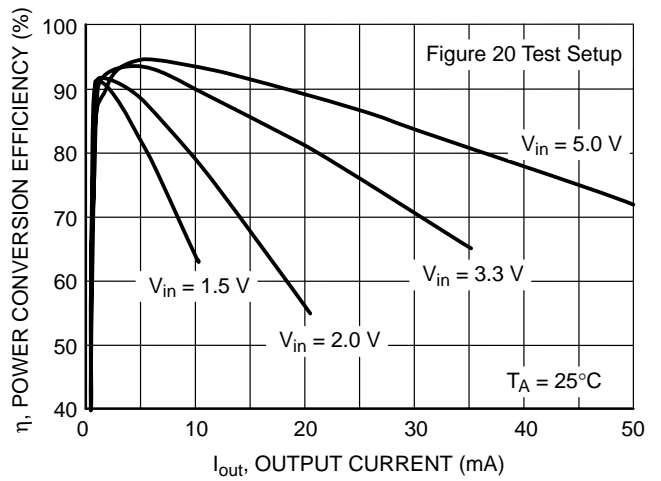
**Figure 14. Output Voltage vs. Output Current MAX828**



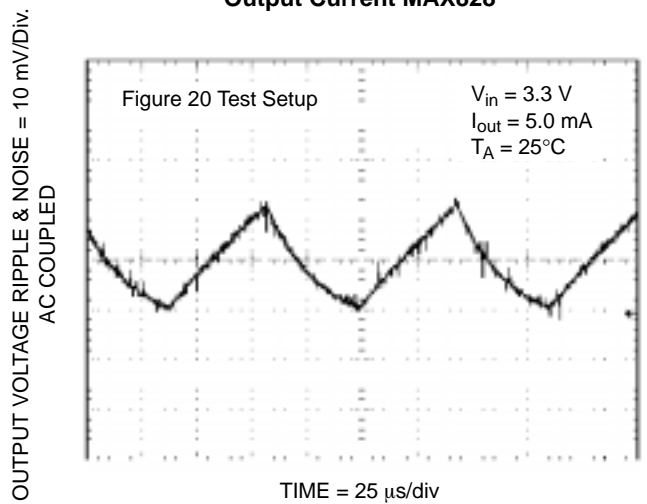
**Figure 15. Output Voltage vs. Output Current MAX829**



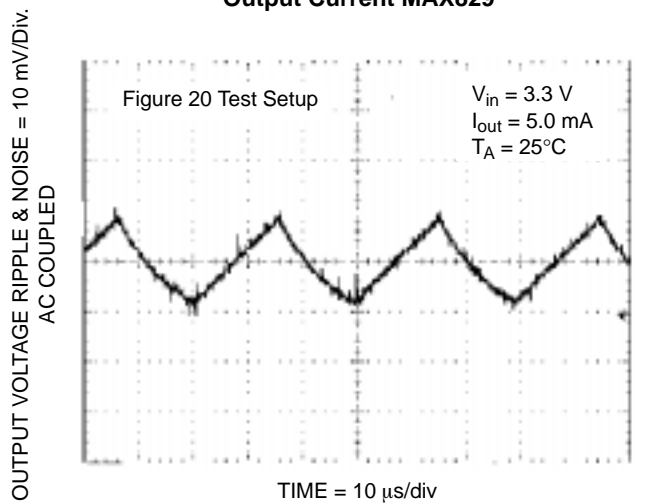
**Figure 16. Power Conversion Efficiency vs. Output Current MAX828**



**Figure 17. Power Conversion Efficiency vs. Output Current MAX829**



**Figure 18. Output Voltage Ripple and Noise MAX828**



**Figure 19. Output Voltage Ripple and Noise MAX829**

## MAX828, MAX829

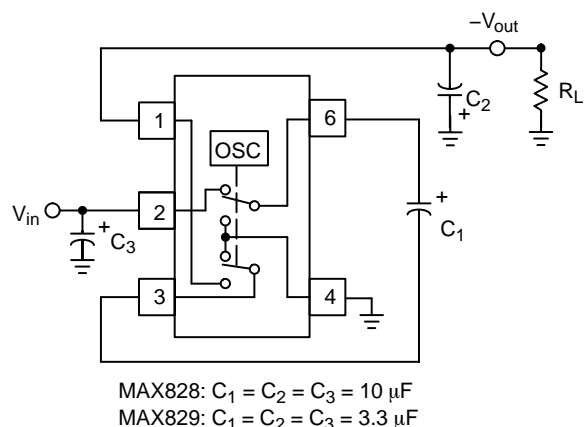


Figure 20. Test Setup/Voltage Inverter

### DETAILED OPERATING DESCRIPTION

The MAX828/829 charge pump converts the voltage applied to the  $V_{in}$  pin. Conversion consists of a two-phase operation (Figure 21). During the first phase, switches  $S_2$  and  $S_4$  are open and  $S_1$  and  $S_3$  are closed. During this time,  $C_1$  charges to the voltage on  $V_{in}$  and load current is supplied from  $C_2$ . During the second phase,  $S_2$  and  $S_4$  are closed, and  $S_1$  and  $S_3$  are open. This action connects  $C_1$  across  $C_2$ , restoring charge to  $C_2$ .

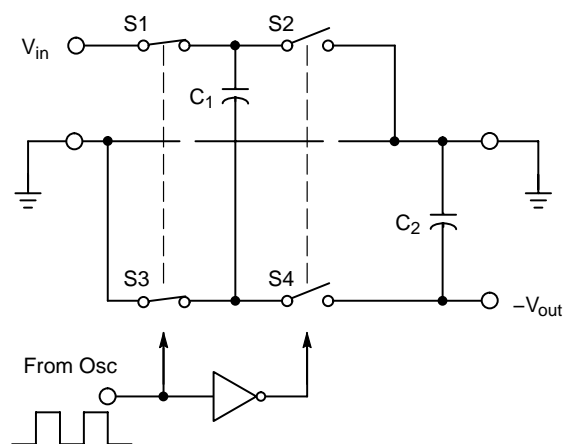


Figure 21. Ideal Switched Capacitor Charge Pump

### APPLICATIONS INFORMATION

#### Output Voltage Considerations

The MAX828/829 performs voltage conversion but does not provide regulation. The output voltage will drop in a linear manner with respect to load current. The value of this equivalent output resistance is approximately  $26 \Omega$  nominal at  $25^\circ\text{C}$  and  $V_{in} = 5.0 \text{ V}$ .  $V_{out}$  is approximately  $-5.0 \text{ V}$  at light loads, and drops according to the equation below:

$$V_{DROP} = I_{out} \times R_{out}$$

$$V_{out} = -(V_{in} - V_{DROP})$$

#### Charge Pump Efficiency

The overall power efficiency of the charge pump is affected by four factors:

1. Losses from power consumed by the internal oscillator, switch drive, etc. (which vary with input voltage, temperature and oscillator frequency).
2. I<sup>2</sup>R losses due to the on-resistance of the MOSFET switches on-board the charge pump.
3. Charge pump capacitor losses due to Equivalent Series Resistance (ESR).
4. Losses that occur during charge transfer from the commutation capacitor to the output capacitor when a voltage difference between the two capacitors exists.

Most of the conversion losses are due to factors 2, 3 and 4. These losses are given by Equation 1.

$$P_{LOSS(2,3,4)} = I_{out}^2 \times R_{out} \cong I_{out}^2 \times \left[ \frac{1}{(f_{OSC})C_1} + 8R_{SWITCH} + 4ESR_{C_1} + ESR_{C_2} \right] \quad (\text{eq. 1})$$

The  $1/(f_{OSC})(C_1)$  term in Equation 1 is the effective output resistance of an ideal switched capacitor circuit (Figures 22 and 23).

The losses due to charge transfer above are also shown in Equation 2. The output voltage ripple is given by Equation 3.

$$P_{LOSS} = [0.5C_1 (V_{in}^2 - V_{out}^2) + 0.5C_2 (V_{RIPPLE}^2 - 2V_{out}V_{RIPPLE})] \times f_{OSC} \quad (\text{eq. 2})$$

$$V_{RIPPLE} = \frac{I_{out}}{(f_{OSC})(C_2)} + 2(I_{out})(ESR_{C_2}) \quad (\text{eq. 3})$$

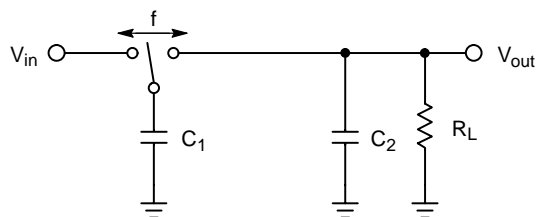


Figure 22. Ideal Switched Capacitor Model

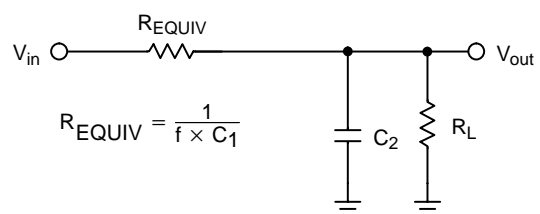


Figure 23. Equivalent Output Resistance

## MAX828, MAX829

### Capacitor Selection

In order to maintain the lowest output resistance and output ripple voltage, it is recommended that low ESR capacitors be used. Additionally, larger values of  $C_1$  will lower the output resistance and larger values of  $C_2$  will reduce output voltage ripple. (See Equation 3).

Table 1 shows various values of  $C_1$ ,  $C_2$  and  $C_3$  with the corresponding output resistance values at 25°C. Table 2 shows the output voltage ripple for various values of  $C_1$ ,  $C_2$  and  $C_3$ . The data in Tables 1 and 2 was measured not calculated.

**Table 1. Output Resistance vs. Capacitance**  
( $C_1 = C_2 = C_3$ ),  $V_{in} = 4.75\text{ V}$  and  $V_{out} = -4.0\text{ V}$

$C_1 = C_2 = C_3$ ( $\mu\text{F}$ )	MAX828 $R_{out}$ ( $\Omega$ )	MAX829 $R_{out}$ ( $\Omega$ )
0.7	127.2	55.7
1.4	67.7	36.8
3.3	36	26.0
7.3	26.7	24.9
10	25.9	25.1
24	24.3	25.2
50	24	24

**Table 2. Output Voltage Ripple vs. Capacitance**  
( $C_1 = C_2 = C_3$ ),  $V_{in} = 4.75\text{ V}$  and  $V_{out} = -4.0\text{ V}$

$C_1 = C_2 = C_3$ ( $\mu\text{F}$ )	MAX828 Ripple (mV)	MAX829 Ripple (mV)
0.7	377.5	320
1.4	360.5	234
3.3	262	121
7.3	155	62.1
10	126	51.25
24	55.1	25.2
50	36.6	27.85

### Input Supply Bypassing

The input voltage,  $V_{in}$  should be capacitively bypassed to reduce AC impedance and minimize noise effects due to the switching internals in the device. If the device is loaded from  $V_{out}$  to GND, it is recommended that a large value capacitor (at least equal to  $C_1$ ) be connected from  $V_{in}$  to GND. If the device is loaded from  $V_{in}$  to  $V_{out}$  a small ( $0.7\ \mu\text{F}$ ) capacitor between the pins is sufficient.

### Voltage Inverter

The most common application for a charge pump is the voltage inverter (Figure 20). This application uses two or three external capacitors. The capacitors  $C_1$  (pump capacitor) and  $C_2$  (output capacitor) are required. The input bypass capacitor  $C_3$ , may be necessary depending on the application. The output is equal to  $-V_{in}$  plus any voltage drops due to loading. Refer to Tables 1 and 2 for capacitor selection. The test setup used for the majority of the characterization is shown in Figure 20.

### Layout Considerations

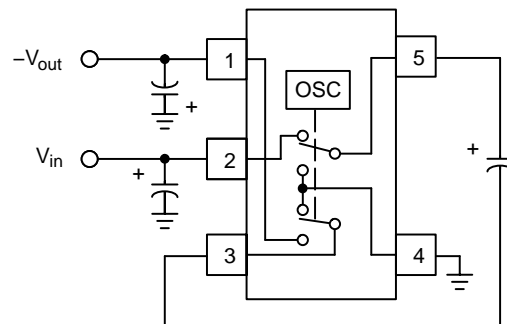
As with any switching power supply circuit, good layout practice is recommended. Mount components as close together as possible to minimize stray inductance and capacitance. Also use a large ground plane to minimize noise leakage into other circuitry.

### Capacitor Resources

Selecting the proper type of capacitor can reduce switching loss. Low ESR capacitors are recommended. The MAX828 and MAX829 were characterized using the capacitors listed in Table 3. This list identifies low ESR capacitors for the voltage inverter application.

**Table 3. Capacitor Types**

Manufacturer/Contact	Part Types/Series
<b>AVX</b> 843-448-9411 www.avxcorp.com	TPS
<b>Cornell Dubilier</b> 508-996-8561 www.cornell-dubilier.com	ESRD
<b>Sanyo/Os-con</b> 619-661-6835 www.sanyovideo.com/oscon.htm	SN SVP
<b>Vishay</b> 603-224-1961 www.vishay.com	593D 594

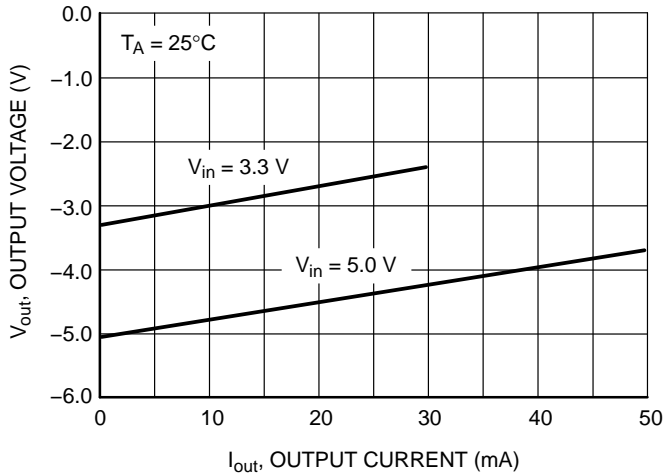


MAX828: Capacitors = 10  $\mu\text{F}$   
MAX829: Capacitors = 3.3  $\mu\text{F}$

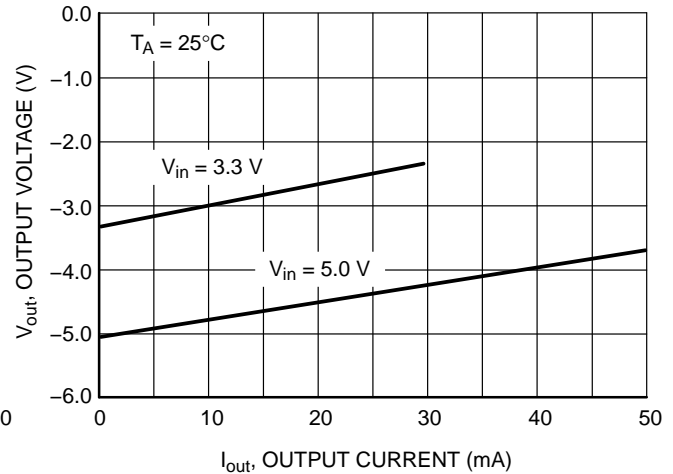
**Figure 24. Voltage Inverter**

## MAX828, MAX829

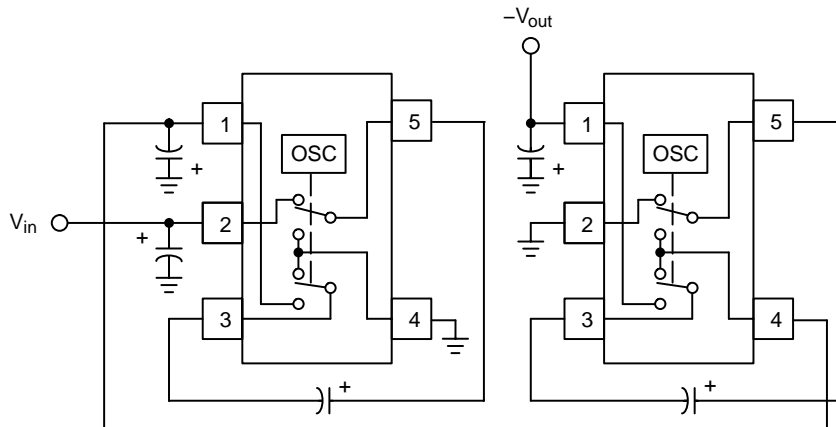
The MAX828 / 829 primary function is a voltage inverter. The device will convert 5.0 V into -5.0 V with light loads. Two capacitors are required for the inverter to function. A third capacitor, the input bypass capacitor, may be required depending on the power source for the inverter. The performance for this device is illustrated below.



**Figure 25. Voltage Inverter Load Regulation Output Voltage vs. Output Current MAX828**



**Figure 26. Voltage Inverter Load Regulation Output Voltage vs. Output Current MAX829**



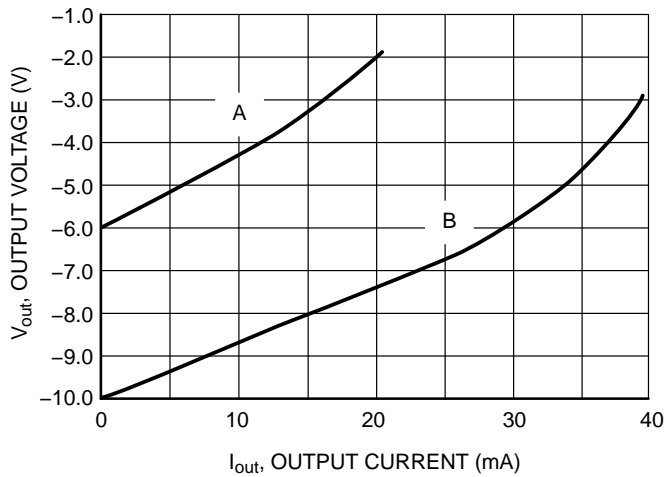
MAX828 Capacitors = 10  $\mu$ F  
MAX829 Capacitors = 3.3  $\mu$ F

**Figure 27. Cascade Devices for Increased Negative Output Voltage**

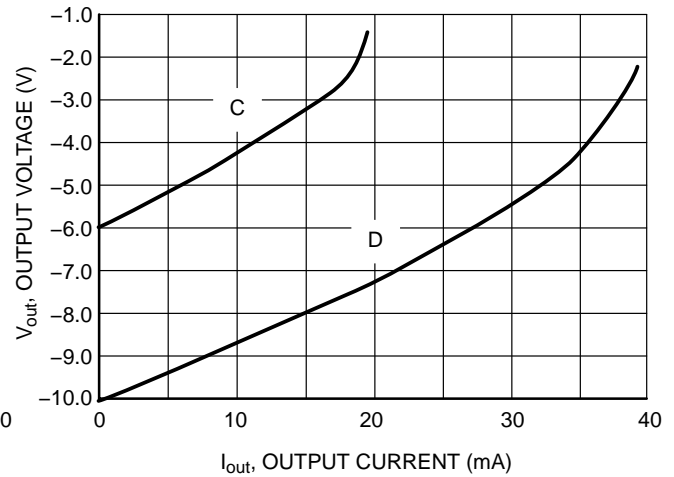
Two or more devices can be cascaded for increased output voltage. Under light load conditions, the output voltage is approximately equal to  $-V_{in}$  times the number of stages. The converter output resistance increases dramatically with each additional stage. This is due to a reduction of input voltage to each successive stage as the converter output is loaded. Note that the ground connection for each successive stage must connect to the negative output of the previous stage. The performance characteristics for a converter consisting of two cascaded devices are shown below.



## MAX828, MAX829

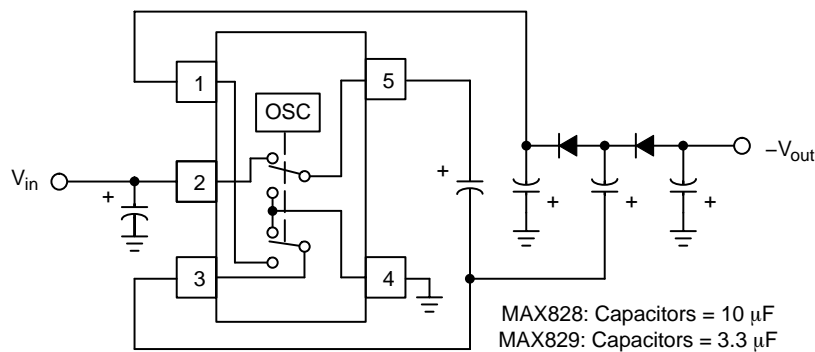


**Figure 28. Cascade Load Regulation, Output Voltage vs. Output Current MAX828**



**Figure 29. Cascade Load Regulation, Output Voltage vs. Output Current MAX829**

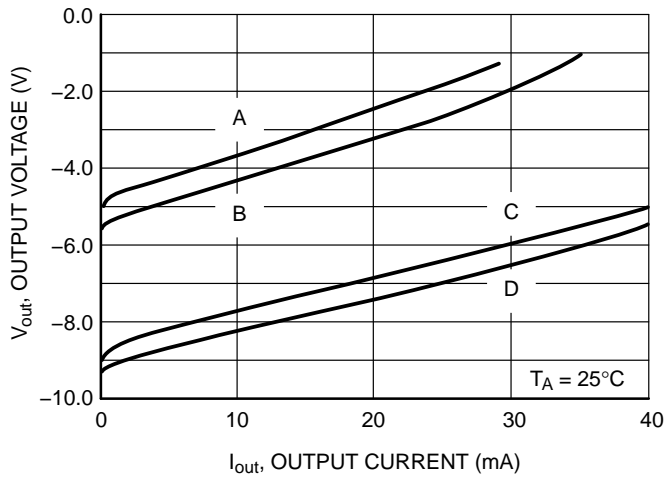
Curve	$V_{in}$ (V)	$R_{out}$ ( $\Omega$ )
A	3.0	173
B	5.0	141
C	3.0	179
D	5.0	147



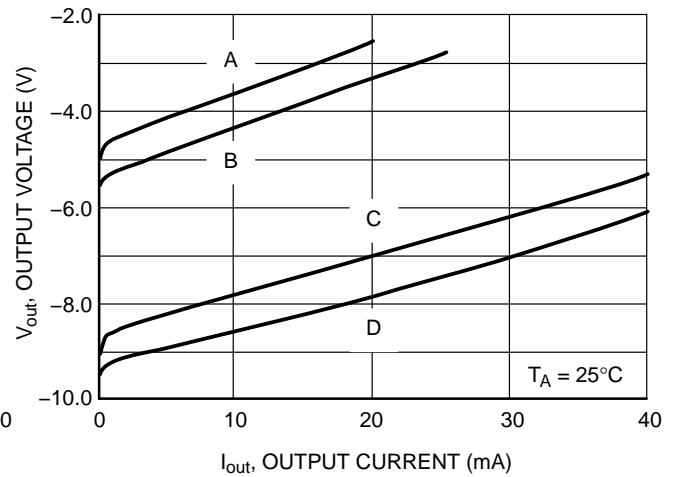
**Figure 30. Negative Output Voltage Doubler**

A single device can be used to construct a negative voltage doubler. The output voltage is approximately equal to  $-2V_{in}$  minus the forward voltage drop of each external diode. The performance characteristics for the above converter are shown below. Note that curves A and C show the circuit performance with economical 1N4148 diodes, while curves B and D are with lower loss MBRA120E Schottky diodes.

## MAX828, MAX829

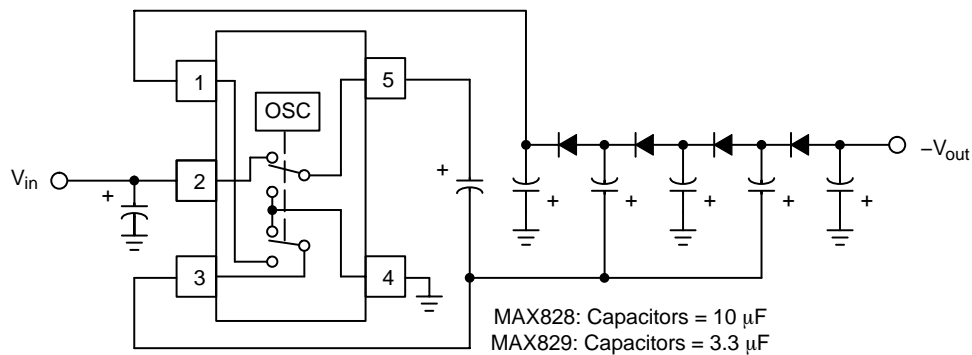


**Figure 31. Doubler Load Regulation, Output Voltage vs. Output Current MAX828**



**Figure 32. Doubler Load Regulation, Output Voltage vs. Output Current MAX829**

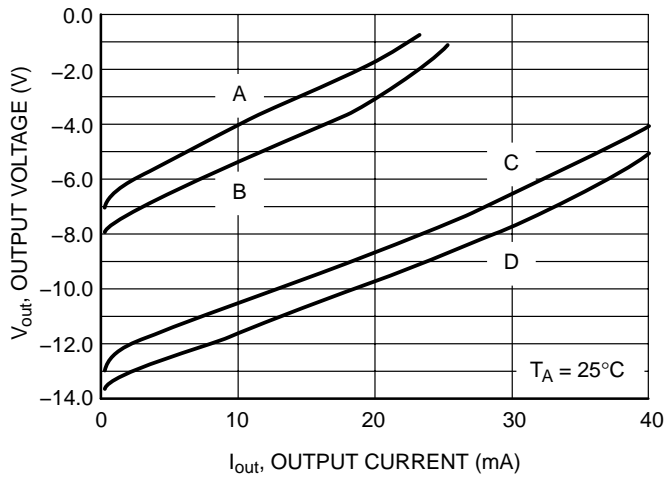
Curve	$V_{in}$ (V)	Diodes	MAX828 $R_{out}$ ( $\Omega$ )	MAX829 $R_{out}$ ( $\Omega$ )
A	3.0	1N4148	122	118
B	3.0	MBRA120E	114	106
C	5.0	1N4148	96	90
D	5.0	MBRA120E	91	87



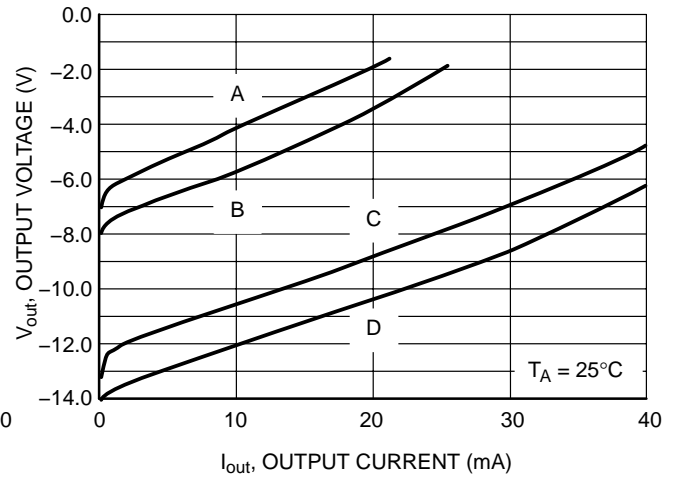
**Figure 33. Negative Output Voltage Tripler**

A single device can be used to construct a negative voltage tripler. The output voltage is approximately equal to  $-3V_{in}$  minus the forward voltage drop of each external diode. The performance characteristics for the above converter are shown below. Note that curves A and C show the circuit performance with economical 1N4148 diodes, while curves B and D are with lower loss MBRA120E Schottky diodes.

## MAX828, MAX829

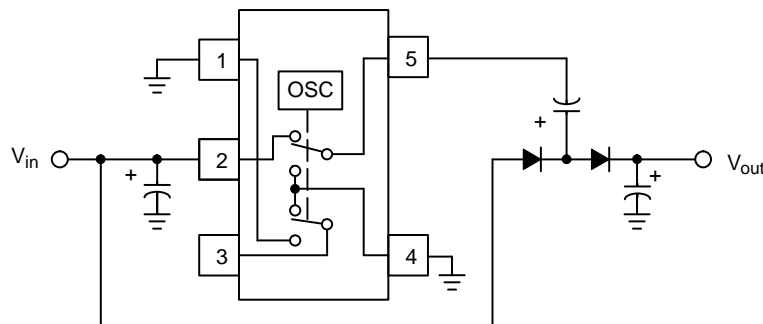


**Figure 34. Tripler Load Regulation, Output Voltage vs. Output Current MAX828**



**Figure 35. Tripler Load Regulation, Output Voltage vs. Output Current MAX829**

Curve	$V_{in}$ (V)	Diodes	MAX828 $R_{out}$ ( $\Omega$ )	MAX829 $R_{out}$ ( $\Omega$ )
A	3.0	1N4148	259	246
B	3.0	MBRA120E	251	237
C	5.0	1N4148	209	198
D	5.0	MBRA120E	192	185

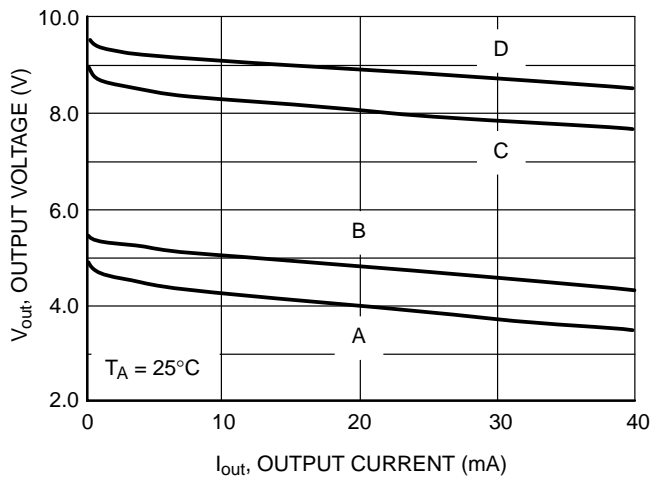


MAX828: Capacitors = 10  $\mu$ F  
 MAX829: Capacitors = 3.3  $\mu$ F

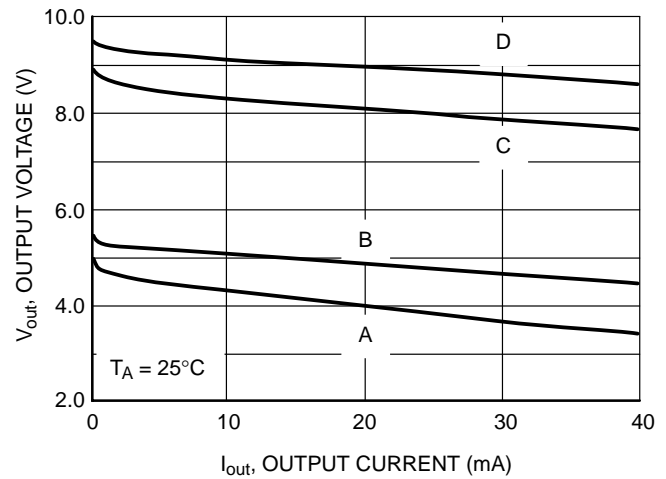
**Figure 36. Positive Output Voltage Doubler**

A single device can be used to construct a positive voltage doubler. The output voltage is approximately equal to  $2V_{in}$  minus the forward voltage drop of each external diode. The performance characteristics for the above converter are shown below. Note that curves A and C show the circuit performance with economical 1N4148 diodes, while curves B and D are with lower loss MBRA120E Schottky diodes.

## MAX828, MAX829

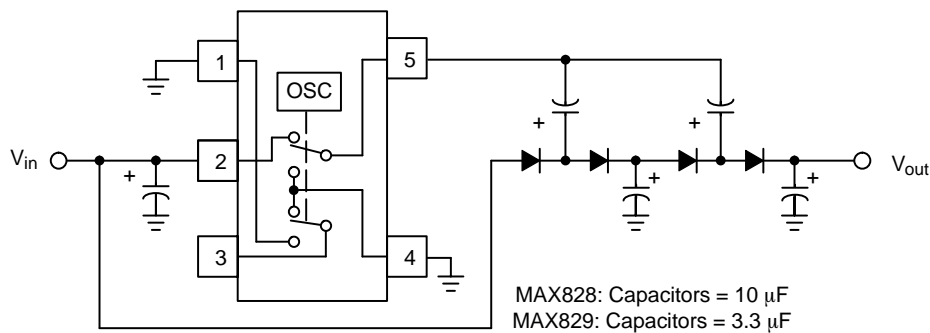


**Figure 37. Doubler Load Regulation, Output Voltage vs. Output Current MAX828**



**Figure 38. Doubler Load Regulation, Output Voltage vs. Output Current MAX829**

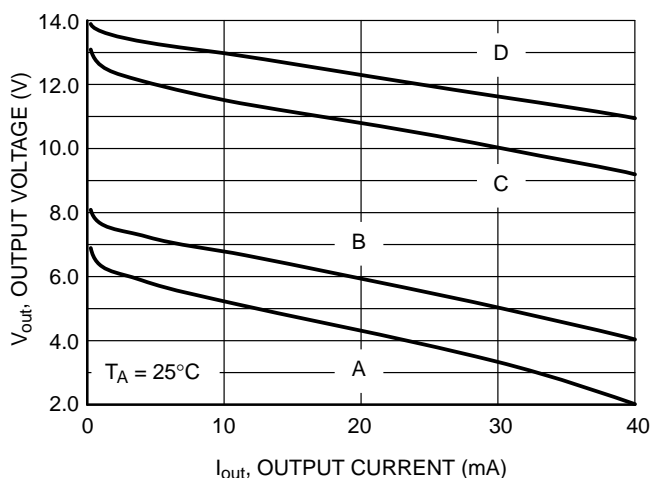
Curve	$V_{in}$ (V)	Diodes	MAX828 $R_{out}$ ( $\Omega$ )	MAX829 $R_{out}$ ( $\Omega$ )
A	3.0	1N4148	32.5	32.2
B	3.0	MBRA120E	27.1	25.7
C	5.0	1N4148	26.0	25.1
D	5.0	MBRA120E	21.2	19.0



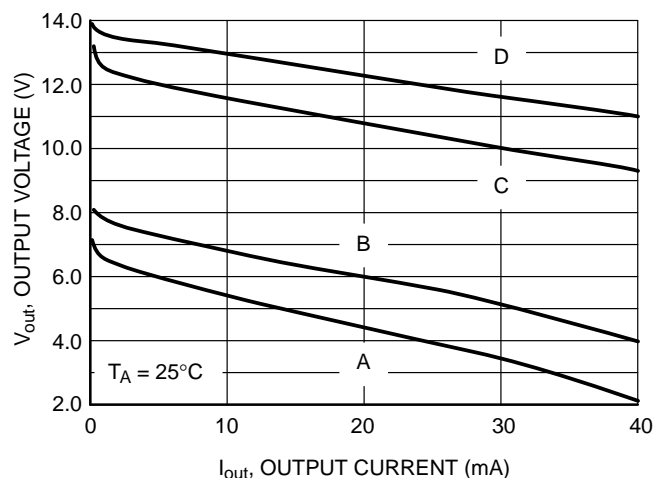
**Figure 39. Positive Output Voltage Tripler**

A single device can be used to construct a positive voltage tripler. The output voltage is approximately equal to  $3V_{in}$  minus the forward voltage drop of each external diode. The performance characteristics for the above converter are shown below. Note that curves A and C show the circuit performance with economical 1N4148 diodes, while curves B and D are with lower loss MBRA120E Schottky diodes.

## MAX828, MAX829

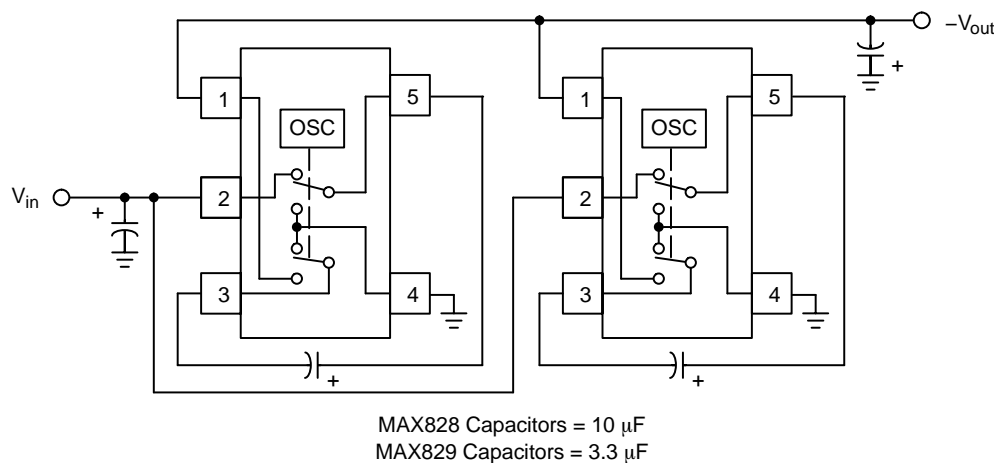


**Figure 40. Tripler Load Regulation, Output Voltage vs. Output Current MAX828**



**Figure 41. Tripler Load Regulation, Output Voltage vs. Output Current MAX829**

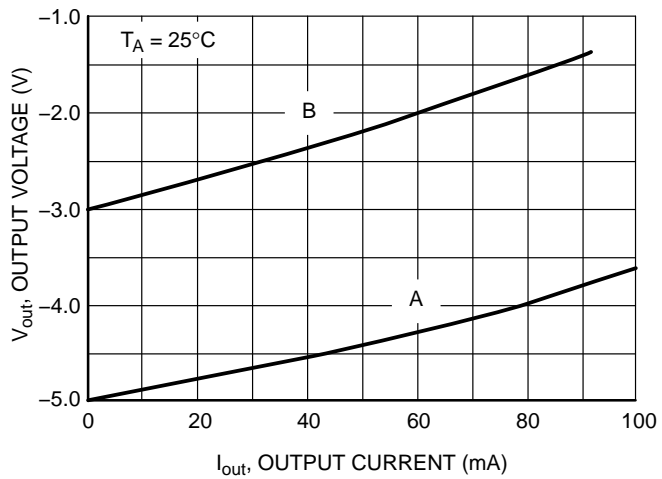
Curve	$V_{in}$ (V)	Diodes	MAX828 $R_{out}$ ( $\Omega$ )	MAX829 $R_{out}$ ( $\Omega$ )
A	3.0	1N4148	110	111
B	3.0	MBRA120E	96.5	96.7
C	5.0	1N4148	84.5	87.3
D	5.0	MBRA120E	78.2	77.1



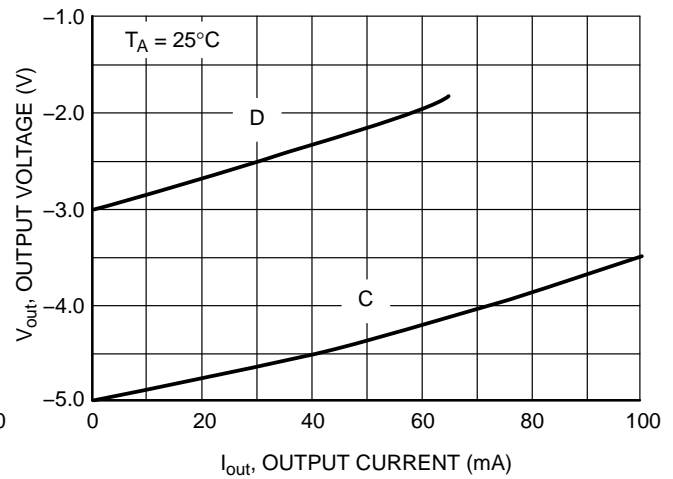
**Figure 42. Paralleling Devices for Increased Negative Output Current**

An increase in converter output current capability with a reduction in output resistance can be obtained by paralleling two or more devices. The output current capability is approximately equal to the number of devices paralleled. A single shared output capacitor is sufficient for proper operation but each device does require its own pump capacitor. Note that the output ripple frequency will be complex since the oscillators are not synchronized. The output resistance is approximately equal to the output resistance of one device divided by the total number of devices paralleled. The performance characteristics for a converter consisting of two paralleled devices is shown below.

## MAX828, MAX829

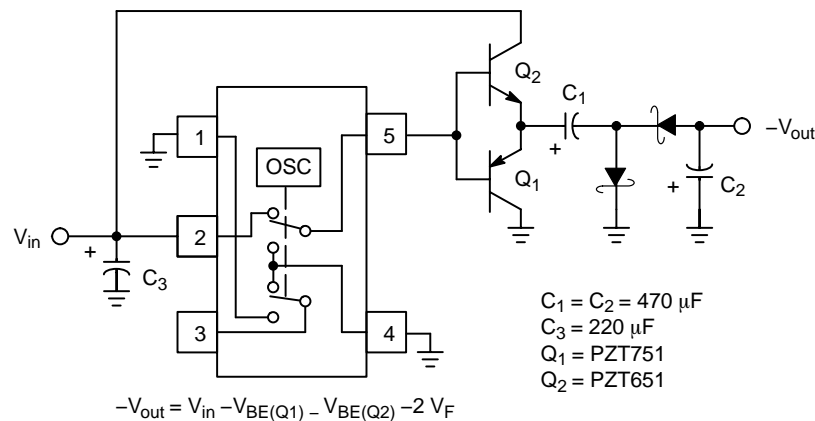


**Figure 43. Parallel Load Regulation, Output Voltage vs. Output Current MAX828**



**Figure 44. Parallel Load Regulation, Output Voltage vs. Output Current MAX829**

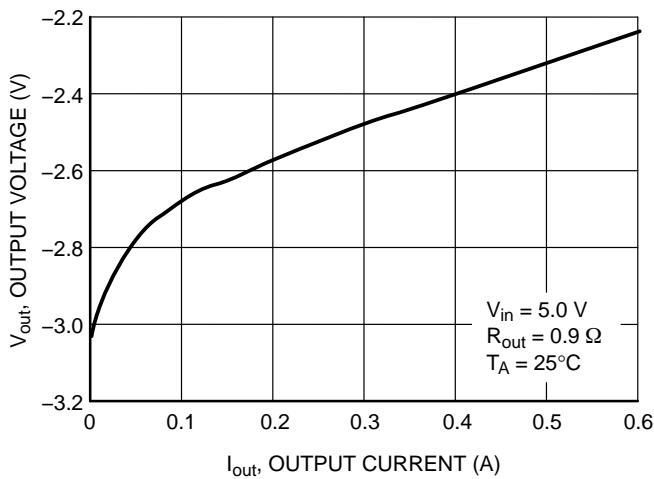
Curve	$V_{in}$ (V)	$R_{out}$ ( $\Omega$ )
A	5.0	13.3
B	3.0	17.3
C	5.0	14.4
D	3.0	17.3



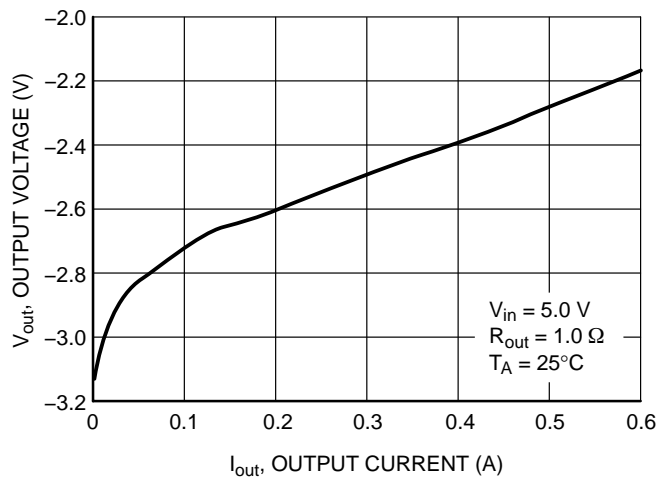
**Figure 45. External Switch for Increased Negative Output Current**

The output current capability of the MAX828 and MAX829 can be extended beyond 600 mA with the addition of two external switch transistors and two Schottky diodes. The output voltage is approximately equal to  $-V_{in}$  minus the sum of the base emitter drops of both transistors and the forward voltage of both diodes. The performance characteristics for the converter are shown below. Note that the output resistance is reduced to 0.9 and 1.0 ohms for the 828 and 829 respectively.

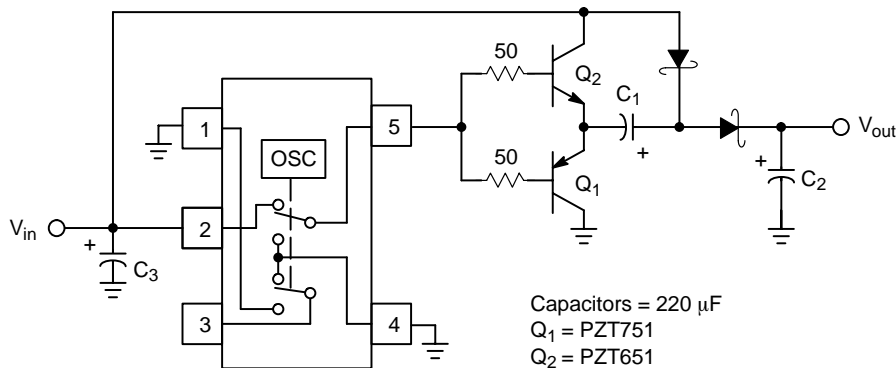
## MAX828, MAX829



**Figure 46. Current Boosted Load Regulation, Output Voltage vs. Output Current MAX828**

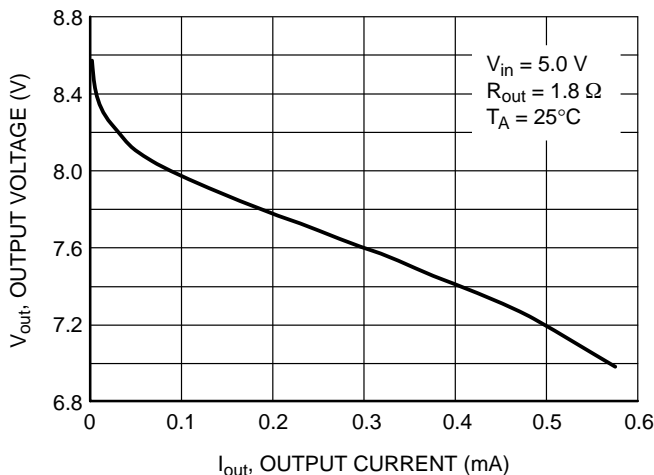


**Figure 47. Current Boosted Load Regulation, Output Voltage vs. Output Current MAX829**

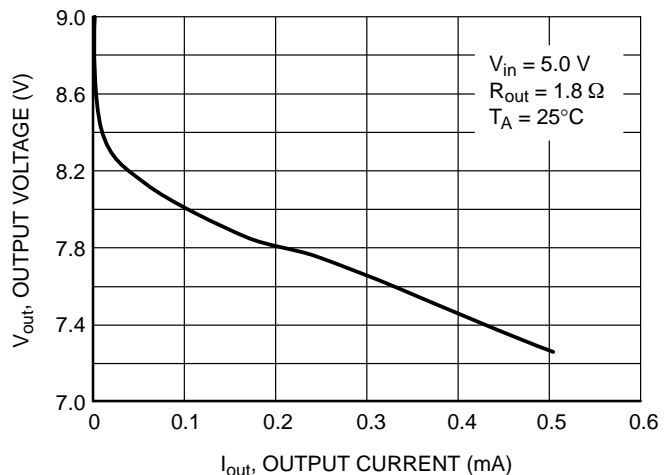


**Figure 48. Positive Output Voltage Doubler with High Current Capability**

The MAX828/829 can be configured to produce a positive output voltage doubler with current capability in excess of 500 mA. This is accomplished with the addition of two external switch transistors and two Schottky diodes. The output voltage is approximately equal to  $2V_{in}$  minus the sum of the base emitter drops of both transistors and the forward voltage of both diodes. The performance characteristics for the converter are shown below. Note that the output resistance is reduced to  $1.8 \Omega$ .

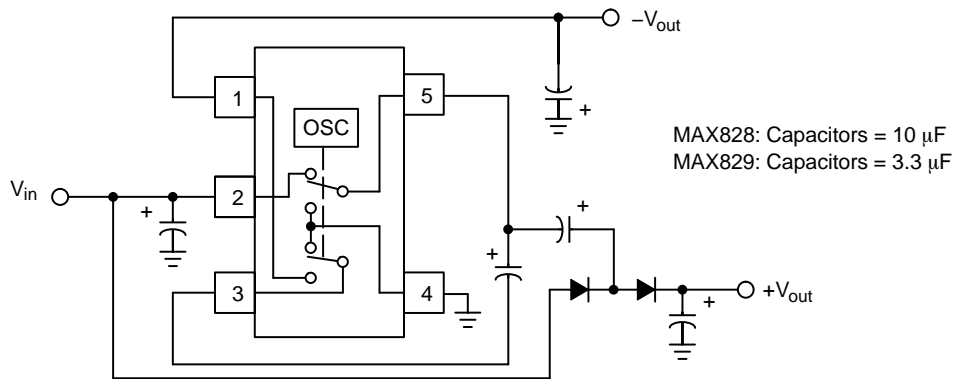


**Figure 49. Positive Doubler with Current Boosted Load Regulation, Output Voltage vs. Output Current, MAX828**



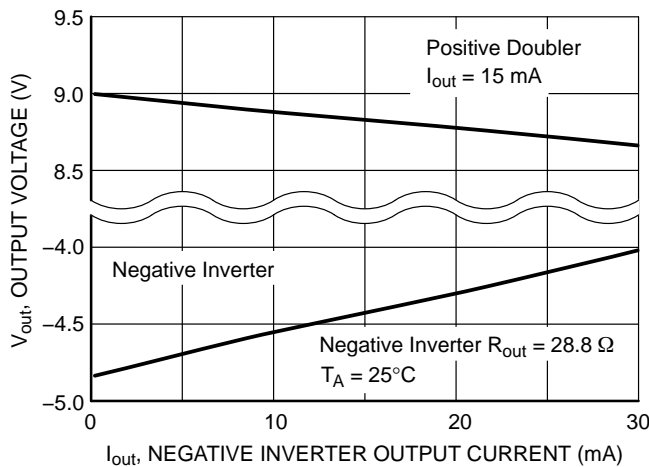
**Figure 50. Positive Doubler with Current Boosted Load Regulation, Output Voltage vs. Output Current, MAX829**

## MAX828, MAX829

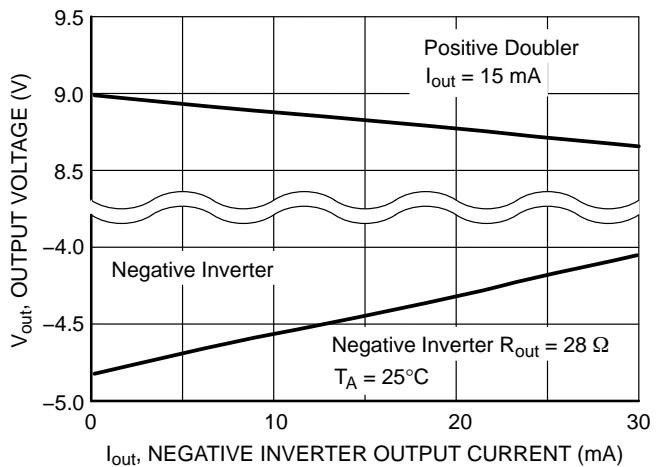


**Figure 51. A Positive Doubler, with a Negative Inverter**

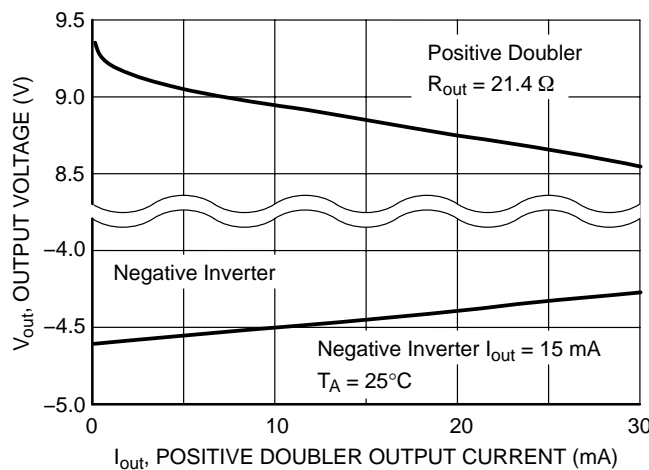
All of the previously shown converter circuits have only single outputs. Applications requiring multiple outputs can be constructed by incorporating combinations of the former circuits. The converter shown above combines Figures 24 and 36 to form a negative output inverter with a positive output doubler. Different combinations of load regulation are shown below. In Figures 52 and 53 the positive doubler has a constant  $I_{out} = 15$  mA while the negative inverter has the variable load. In Figures 54 and 55 the negative inverter has the constant  $I_{out} = 15$  mA and the positive doubler has the variable load.



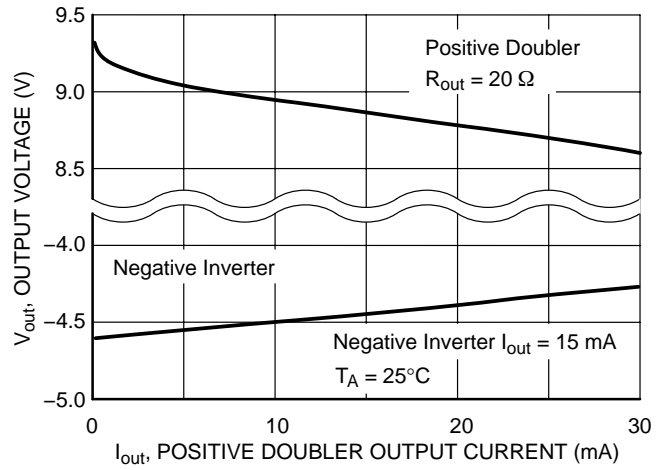
**Figure 52. Negative Inverter Load Regulation, Output Voltage vs. Output Current, MAX828**



**Figure 53. Negative Inverter Load Regulation, Output Voltage vs. Output Current, MAX829**



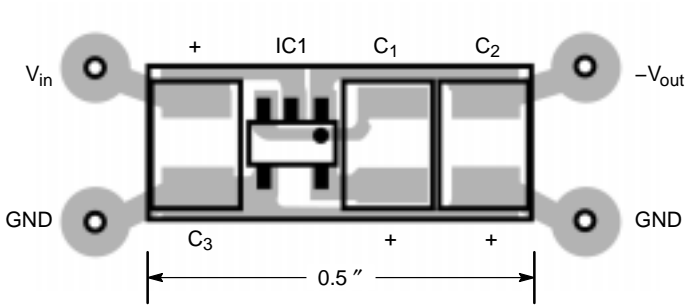
**Figure 54. Positive Doubler Load Regulation, Output Voltage vs. Output Current, MAX828**



**Figure 55. Positive Doubler Load Regulation, Output Voltage vs. Output Current, MAX829**



**MAX828, MAX829**



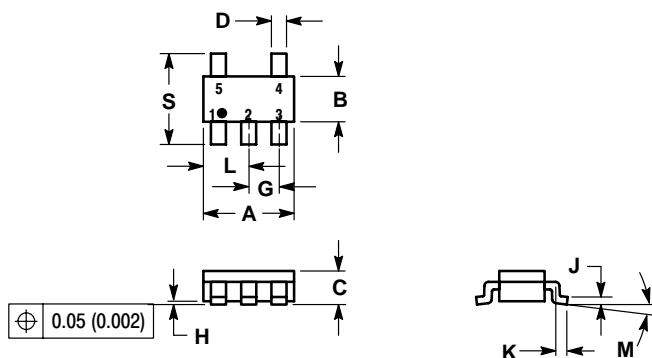
Inverter Size = 0.5 in x 0.2 in  
Area = 0.10 in<sup>2</sup>, 64.5 mm<sup>2</sup>

**Figure 56. Inverter Circuit Board Layout,  
Top View Copper Side**

# MAX828, MAX829

## PACKAGE DIMENSIONS

### THIN SOT-23-5 PLASTIC PACKAGE CASE 483-01 ISSUE A

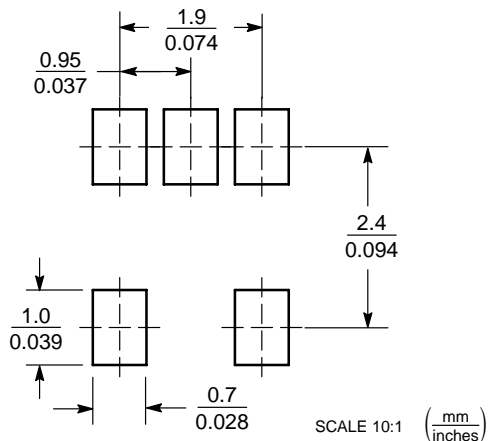


#### NOTES:

1. DIMENSIONING AND TOLERANCING PER ANSI Y14.5M, 1982.
2. CONTROLLING DIMENSION: MILLIMETER.
3. MAXIMUM LEAD THICKNESS INCLUDES LEAD FINISH THICKNESS. MINIMUM LEAD THICKNESS IS THE MINIMUM THICKNESS OF BASE MATERIAL.

DIM	MILLIMETERS		INCHES	
	MIN	MAX	MIN	MAX
A	2.90	3.10	0.1142	0.1220
B	1.30	1.70	0.0512	0.0669
C	0.90	1.10	0.0354	0.0433
D	0.25	0.50	0.0098	0.0197
G	0.85	1.00	0.0335	0.0413
H	0.013	0.100	0.0005	0.0040
J	0.10	0.26	0.0040	0.0102
K	0.20	0.60	0.0079	0.0236
L	1.25	1.55	0.0493	0.0610
M	0°	10°	0°	10°
S	2.50	3.00	0.0985	0.1181

### SOLDERING FOOTPRINT\*



\*For additional information on our Pb-Free strategy and soldering details, please download the ON Semiconductor Soldering and Mounting Techniques Reference Manual, SOLDERRM/D.

ON Semiconductor and are registered trademarks of Semiconductor Components Industries, LLC (SCILLC). SCILLC reserves the right to make changes without further notice to any products herein. SCILLC makes no warranty, representation or guarantee regarding the suitability of its products for any particular purpose, nor does SCILLC assume any liability arising out of the application or use of any product or circuit, and specifically disclaims any and all liability, including without limitation special, consequential or incidental damages. "Typical" parameters which may be provided in SCILLC data sheets and/or specifications can and do vary in different applications and actual performance may vary over time. All operating parameters, including "Typicals" must be validated for each customer application by customer's technical experts. SCILLC does not convey any license under its patent rights nor the rights of others. SCILLC products are not designed, intended, or authorized for use as components in systems intended for surgical implant into the body, or other applications intended to support or sustain life, or for any other application in which the failure of the SCILLC product could create a situation where personal injury or death may occur. Should Buyer purchase or use SCILLC products for any such unintended or unauthorized application, Buyer shall indemnify and hold SCILLC and its officers, employees, subsidiaries, affiliates, and distributors harmless against all claims, costs, damages, and expenses, and reasonable attorney fees arising out of, directly or indirectly, any claim of personal injury or death associated with such unintended or unauthorized use, even if such claim alleges that SCILLC was negligent regarding the design or manufacture of the part. SCILLC is an Equal Opportunity/Affirmative Action Employer. This literature is subject to all applicable copyright laws and is not for resale in any manner.

### PUBLICATION ORDERING INFORMATION

#### LITERATURE FULFILLMENT:

Literature Distribution Center for ON Semiconductor  
P.O. Box 61312, Phoenix, Arizona 85082-1312 USA  
Phone: 480-829-7710 or 800-344-3860 Toll Free USA/Canada  
Fax: 480-829-7709 or 800-344-3867 Toll Free USA/Canada  
Email: orderlit@onsemi.com

N. American Technical Support: 800-282-9855 Toll Free  
USA/Canada

Japan: ON Semiconductor, Japan Customer Focus Center  
2-9-1 Kamimeguro, Meguro-ku, Tokyo, Japan 153-0051  
Phone: 81-3-5773-3850

ON Semiconductor Website: <http://onsemi.com>

Order Literature: <http://www.onsemi.com/litorder>

For additional information, please contact your local Sales Representative.